

AVer CB-310

Collaboration Box

User Manual



Federal Communications Commission

NOTE: This equipment has been tested and found to comply with the limits for a Class A digital device, pursuant to part 15 of the FCC Rules. These limits are designed to provide reasonable protection against harmful interference when the equipment is operated in a commercial environment. This equipment generates, uses, and can radiate radio frequency energy and, if not installed and used in accordance with the instruction manual, may cause harmful interference to radio communications. Operation of this equipment in a residential area is likely to cause harmful interference in which case the user will be required to correct the interference at his own expense.

FCC Caution: Any changes or modifications not expressly approved by the party responsible for compliance could void the user's authority to operate this equipment.

This device complies with part 15 of the FCC Rules.

Operation is subject to the following two conditions:

- (1) This device may not cause harmful interference, and
- (2) this device must accept any interference received, including interference that may cause undesired operation.

Warning - This is a Class A product. In a domestic environment this product may cause radio interference in which case the user may be required to take adequate measures to correct this interference.

Europe – EU Declaration of Conformity

This device complies with the essential requirements of the Radio Equipment Directive (2014/53/EU). The following test methods have been applied in order to prove presumption of conformity with the essential requirements of the Radio Equipment Directive (2014/53/EU)

FOR PORTABLE DEVICE USAGE (<20m from body/SAR needed eg. BT dongle, smartphone)

Radiation Exposure Statement:

The product complies with the FCC portable RF exposure limit set forth for an uncontrolled environment and are safe for intended operation as described in this manual. The further RF exposure reduction can be achieved if the product can be kept as far as possible from the user body or set the device to lower output power if such function is available.

FOR MOBILE DEVICE USAGE (>20cm/low power eg. AP routers)

Radiation Exposure Statement:

This equipment complies with FCC radiation exposure limits set forth for an uncontrolled environment. This equipment should be installed and operated with minimum distance 20cm between the radiator & your body.

DISCLAIMER

No warranty or representation, either expressed or implied, is made with respect to the contents of this documentation, its quality, performance, merchantability, or fitness for a particular purpose. Information presented in this documentation has been carefully checked for reliability; however, no responsibility is assumed for inaccuracies. The information contained in this documentation is subject to change without notice.

In no event will AVer Information Inc. be liable for direct, indirect, special, incidental, or consequential damages arising out of the use or inability to use this product or documentation, even if advised of the possibility of such damages.

TRADEMARKS

"AVer" is a trademark owned by AVer Information Inc. Other trademarks used herein for description purpose only belong to each of their companies.

COPYRIGHT

©2020 AVer Information Inc. All rights reserved.

All rights of this object belong to AVer Information Inc. Reproduced or transmitted in any form or by any means without the prior written permission of AVer Information Inc. is prohibited. All information or specifications are subject to change without prior notice.

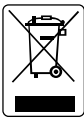

The mark of Crossed-out wheeled bin indicates that this product must not be disposed of with your other household waste. Instead, you need to dispose of the waste equipment by handing it over to a designated collection point for the recycling of waste electrical and electronic equipment. For more information about where to drop off your waste equipment for recycling, please contact your household waste disposal service or the shop where you purchased the product.

Notice

The technical specifications provided in this Manual and on the carton are subject to change without further notice. If there is any difference between this Manual and any actual operation, such actual operation shall prevail.



CAUTION

Hot Surface

Before you move the product, disconnect all external connections and power off the device. Move the product carefully to prevent you from being scalded, especially the device's bottom, which may cause safety issues.



CCA114LP1670T2

CONTACT INFORMATION

Global

AVer Information Inc.

www.aver.com

8F, No.157, Da-An Rd., Tucheng Dist.,

New Taipei City

Taiwan

Tel: +886-2-2269-8535

USA

AVer Information Inc.

www.averusa.com

668 Mission Ct

Fremont, CA 94539, USA

Toll-free: 1(877)528-7824

Local: 1(408)263-3828

Support.usa@aver.com

Safety and Warning

As a valuable offering better audio and visual experience, this product has considered the personal safety factors in design and been tested strictly before delivery. However, improper installation and use may cause electric shock or fire. To ensure its safe use, maintain its service life and bring its best performance into full play, please read and understand the operating instructions and nameplates and observe the following safety precautions carefully before using the product, and keep this Manual properly for future reference.

For your safety, please read the following instruction before you use the product. Serious injury or property loss may be caused by improper operations. Do not try to repair the product by your own.



WARNING



Disconnect the product from power supply immediately if major failures occur.

The major failures include the following:

- Smoke, peculiar smell or abnormal sound is discharged from the product.
- No image or sound is displayed, or the image error occurs.
- Where the mains plug or an appliance coupler is used as the disconnect device the disconnect device shall remain readily operable.

In the preceding scenarios, do not continue to use the product, disconnect power supply immediately and contact professional staff for troubleshooting.

The socket-outlet shall be installed near the equipment and shall be easily accessible.



Do not drop liquid, metal or combustible into the product.

- If any liquid or metal is dropped into the product, power off the product and disconnect power supply, then contact professional staff for solutions.
- Pay attention to the children when they are close to the product.

Do not damage the power cable.

- Do not damage, change, wind, bend, heat or drag the power cable forcibly.
- Do not put weights (such as the product itself) on the power cable.
- Do not drag the cable forcibly when you pull out the power plug. If the power cable is damaged, please contact the local distributor to repair or replace it.
- The power cable in the accessory box is for this product only. Don't use it on other devices.



WARNING

Put the product on a stable surface.

An unstable surface includes and does not limit to an inclined plane, a shaky stand, desk or platform, which might cause the turnover and damage.



Do not open the cover or change the product by your own.

High voltage components are installed in the product. When you open the cover, high voltage, electric shock or other dangerous situations may occur. If inspection, adjustment or maintenance is required, contact the local distributor for help.



Use the specified power supply.

- Do not use any types of power cables other than the one provided with the product to prevent the product from being damaged.
- Use a three-wire socket and ensure that it is properly grounded.
- Pull out the power plug from the socket if the product is not used for a long period.

Before you move the product, disconnect all external connections and separate all toppling preventing devices.

Move the product carefully to prevent it from being hit or squeezed which may cause injury if broken.

Clean the dust and metal on the power plug regularly.

- When you are cleaning, fire or electric shock may be caused if the product is powered on.
- Keep in mind to pull out the power plug before cleaning it by using a dried cloth.



Do not put items on the top of the product.

- Do not put items, such as a container for liquid (a vase, flowerpot, cosmetics or liquid medicine), on the top of the product.
- If any water or liquid is spilled on the product, short circuit may occur and cause fire or electric shock.
- Do not tread on the product or hang any items on the product.



WARNING



Do not install the product in an improper place.

- Do not install the product in humid places, such as the bathroom, the shower room, the place near windows or outdoor environments where experience rain, snow or other harsh weather. The product installation is also required to avoid a place around by hot spring vapor. The preceding environments may cause faults or electric shock under extreme conditions.
- Do not put exposed fire source, such as an ignited candle, on the product.



Pull out the power plug during thunderstorms.

- Do not touch the product when lightning to avoid electric shock.
- Install or place components which power supply voltage is high enough to cause personal injury in places out of the reach of children.



Do not cover or block up any vents on the product.

- The overheated components may cause fire, damage the product and shorten the service life.
- Do not put the venting surface of the product facedown.
- Do not install the product on a carpet or bed clothes.
- Do not use a cloth such as table cloth to cover the product.



Do not touch the power cable with wet hands to avoid electric shock.

Altitude during operation (m): less than 5000m



CAUTION



Do not install the product in high temperature environments.

- Do not install the product near heat source, such as the radiator, the heat reservoir, the stove or other heating devices.
- Do not expose the product under sunlight, which may cause high temperature and subsequent faults in the product.



CAUTION



For transport:

Pack the product for mobility or maintenance by using the cartons and cushioning material provided with the product.



Keep away from the product when you use a radio.

The product design to prevent radio interference complies with the international EMI standard. However, the interference still exists and causes noise in the radio.

- If noise occurs in the radio, try the following solutions.
 - Adjust the direction of the radio antenna to avoid the interference from the product.
 - Keep the radio away from the product.
-
- Sudden temperature or environment humidity changes may cause moisture condensation. This may cause poor picture quality on screen. If this occurs, please keep the device on to evaporate moisture.
 - When the product is not in use for several days, please disconnect product from the power socket for environment and safety reasons.
 - For children, please do not allow children to near the product; keep small accessories out of reach of children, so that they are not mistakenly swallowed.

If protective earthing is used as a safeguard, the instructions shall require connection of the equipment protective earthing conductor to the installation protective earthing conductor (for example, by means of a power cord connected to a socket-outlet with earthing connection).

CONTENTS

Product Overview	1
Package Content.....	1
Accessories	1
I/O Ports	2
Control Panel	3
Pin Definition.....	4
Remote Control.....	5
Installation.....	7
Connect to Laptop/PC	7
Power Connection.....	8
Ethernet Connection	8
HDMI Output Connection.....	8
USB Connection.....	9
Microphone Connection	9
Speaker Connection.....	10
Wall Mount.....	11
Important Safety Instructions	11
Safety information.....	11
Safety tips for installation.....	12
Ventilation.....	13
Using AVer CB-310.....	16
Power On.....	16
Wizard Setup.....	17
Power Off.....	22
Restart.....	23

Screen Lock (Manually).....	24
Mode Switching.....	25
Entry Mode.....	26
Tool menu.....	29
Enable Airplay Onscreen Code.....	30
Advanced Mode.....	33
Basic Information.....	39
Edit the Basic Information.....	39
Disable the Basic Information.....	41
Enable Basic Information.....	42
Notepad.....	43
Disable the Notpad.....	44
Enabel the Notepad.....	45
Schedule.....	46
Edit the Schedule.....	46
Disable the Schedule.....	53
Pinned File.....	54
Enable Pinned File.....	54
Edit the Pinned File.....	55
Disable the Pinned Fie.....	58
Web Search.....	59
Enable the Web Search.....	59
Disable the Web Search.....	60
Tool Bar.....	61
Annotation Tool.....	64
Split-Screen Mode.....	65

Multiple User	67
Enable Multi User.....	67
Add User Account	69
Login with the User Account.....	71
Change the Password.....	73
Delete the User Account	75
Admin Account Management.....	77
Change the Password	77
Change Account Profile	79
Setup User Account Access Authority.....	82
Login with Google Account.....	83
Change Google Account Profile.....	86
Delete the Google User Account	89
Login with Card.....	91
Enable the Login with Card.....	91
Create an Account by Card.....	94
Change the Password of the Account.....	98
Bind the Card for login.....	100
Delete the Account.....	102
Cloud Storage	104
Build an Account.....	104
Open a File from the Cloud Storage	108
Set Password for ES File Explorer.....	111
Whiteboard.....	113
Tutorial.....	113
Note Format.....	114
Import PDF.....	116

Save the PDF file to Google Drive	117
Change Name of the Note	120
Using Whiteboard.....	121
Screen Share	139
Enable Screen Share	139
Setup Screen Share	141
AirPlay Onscreen Code.....	141
Incoming request for authorized connection.....	142
Device Name	144
Sharing content from Apple product to the Collaboration Box.....	145
Sharing content from Chrome solution to the collaboration box.....	150
Sharing content from Windows computer to the panel	154
Sharing content from Android device to the panel	158
Grouping and Draw Function.....	161
Draw Lots	161
Grouging.....	164
Gallery.....	167
Using Browser.....	168
Connect to DoCam.....	169
Internet Connection.....	170
Ethernet Connection	170
Wi-Fi Connection.....	171
Adjust Date and Time.....	173
Power Saving.....	175
Screen Saver.....	175
Energy Saver	176
Screen Lock.....	178

App Lock.....	180
Blue Light Filter.....	183
Volume Adjustment.....	183
Wallpaper.....	184
System Update.....	185
Display Management.....	186
Minimum Server System Requirements.....	186
Login.....	187
Change Password.....	189
Change Email.....	191
Add AVer CB-310 Device.....	192
Power On, OFF, and Reboot AVer CB-310 Device.....	197
Scheduling.....	199
Firmware Update.....	202
Scheduling the Firmware Update.....	202
Update Firmware Now.....	206
View Update Report.....	209
Broadcast.....	210
Broadcast List.....	213
User Account.....	215
Enable Setup from Server.....	216
Add User.....	217
Import List.....	222
Specificaion.....	223
Multimedia Supported Formats.....	224
RS-232 Pin Definition.....	224
RS-232 Send Commands Table.....	224

RS-232Transmission Specifications	225
RS-232Communication Format.....	226
Troubleshooting	227

Product Overview

Package Content

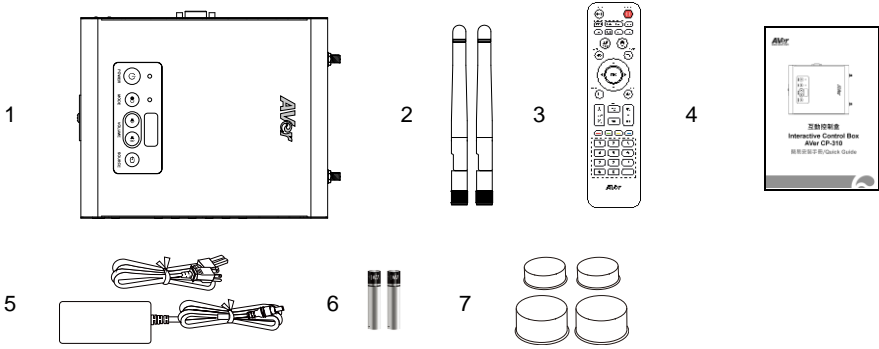

1. CB-310 unit
2. Antenna x 2
3. Remote control
4. Quick Guide
5. Power cord and power adapter
6. AAA battery(for remote controller)
7. Foot rubber x4
(Stick to the four corners at bottom of CB-310)

Accessories

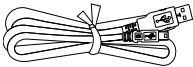

USB cable



HDMI cable

I/O Ports

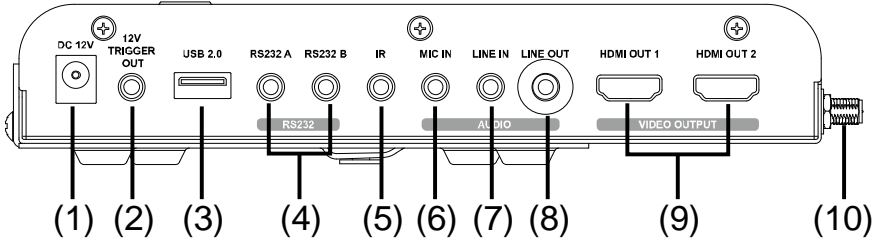

#	Description	#	Description
1	DC power jack	6	MIC input port
2	12V trigger out port	7	Line in port
3	USB 2.0 port	8	Line out port
4	RS232A & RS232B port	9	HDMI1 & HDMI2 output port
5	IR extender port	10	Antenna port

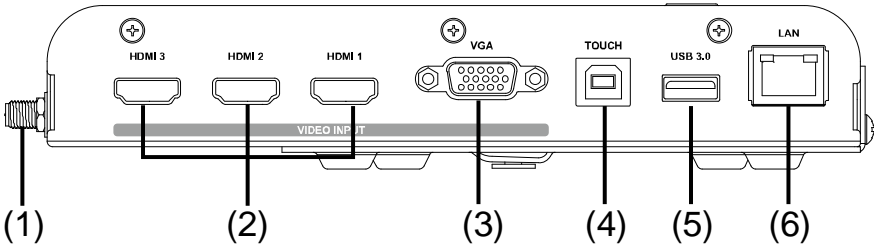

#	Description
1	Antenna port
2	HDMI 1, HDMI2, HDMI3 input port
3	VGA input port
4	Touch-USB port
5	USB 3.0 port
6	Ethernet port (1Gbps)

Control Panel

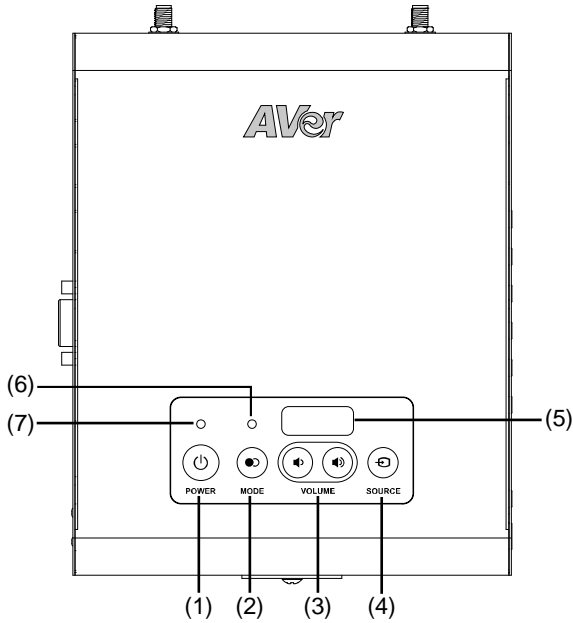

#	Description
1	Power button
2	Mode button
3	Volume +/- button
4	Source button
5	IR receive area
6	LED of mode button(See below table)
7	LED of power button (See below table)

#	Description
Power	<ul style="list-style-type: none"> - Power on: Green - Standby: Red - Power off: Off - Upgrading: Flash Red - Backlight off: Green
Mode	<ul style="list-style-type: none"> - Entry mode: On - Advanced mode: Off

Pin Definition

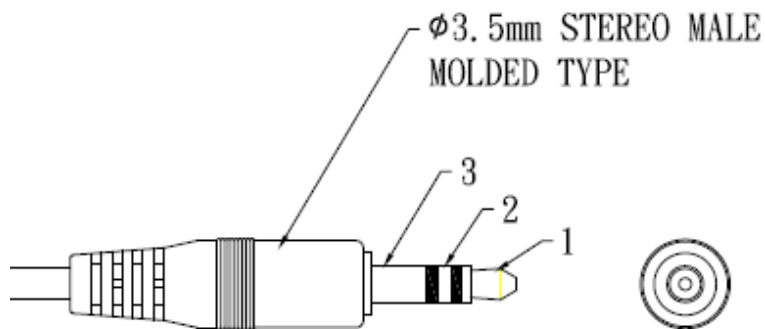

RS232 Pin(PC site)	
1	RX
2	TX
3	GND







IR Pin	
1	VCC
2	IR
3	GND

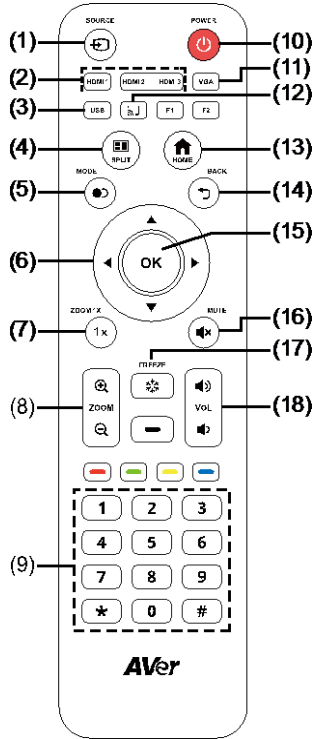









12V Trigger Output	
1	12V
2	NC
3	GND

Remote Control

Please install the battery before using the remote control.



Name	Function
(1) 	Call out the input source selection.
(2) 	Switch to HDMI 1, HDMI2, or HDMI3 input source screen.
(3) 	Switch to USB input source screen.
(4) 	Call out split screen setup screen.
(5) 	Switch between entry and advanced mode.
(6) 	Direction buttons. Use to move between selection while setup.

Name	Function
(7) 	Reset zoom level to 100%
(8) Zoom +/-	Increase/decrease the screen image magnification.
(9) 0~9 buttons	Numbers pad.
(10) 	Call out power off menu. Use ▼ and ▲ to select “SCREEN LOCK”, “RESTART” or “POWER DOWN. Press  button to confirm the selection.
(11) 	Switch to VGA input source screen.
(12) 	Call out the Screen Share app.
(13) 	Back to the main screen.
(14) 	Back to previous page or selection.
(15) 	Confirm the selection.
(16) 	Switch to mute mode.
(17) 	Freeze the screen. Press  button again to un-freeze.
(18) Volume +/-	Adjust the system volume.

Installation

Connect to Laptop/PC

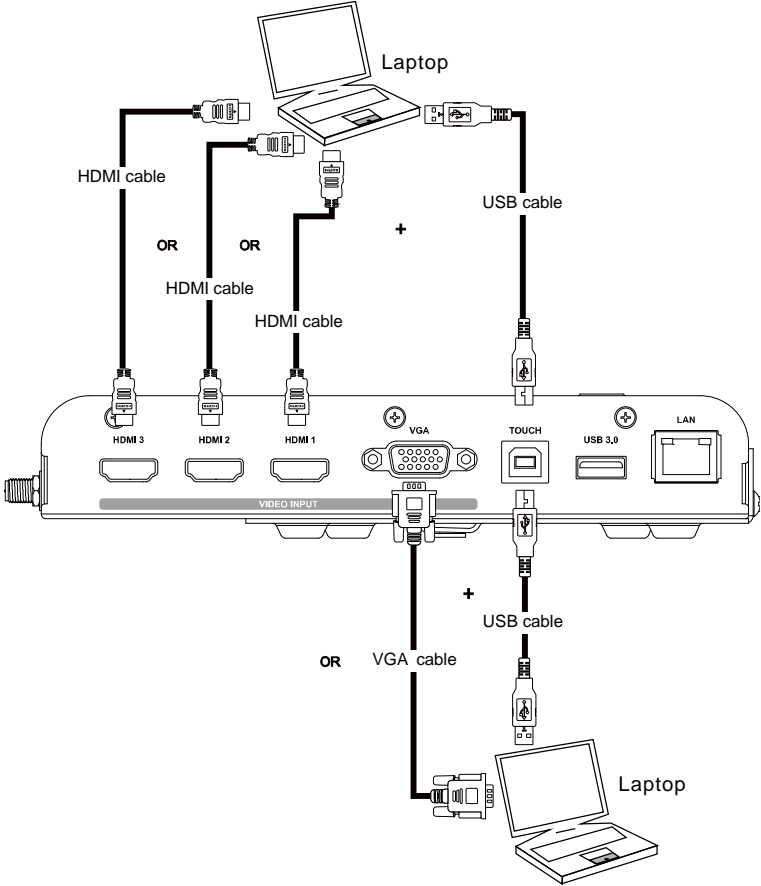

Power Connection

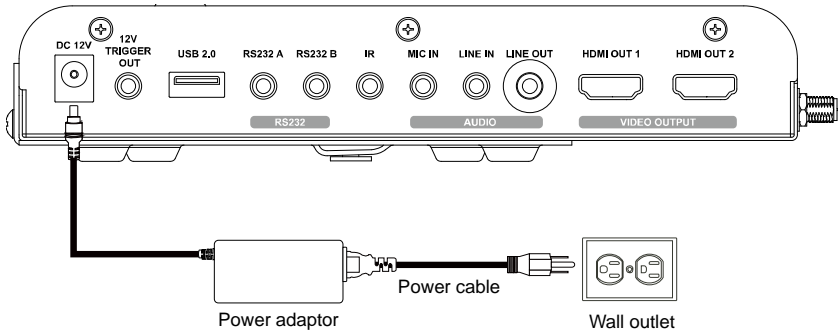

Ethernet Connection

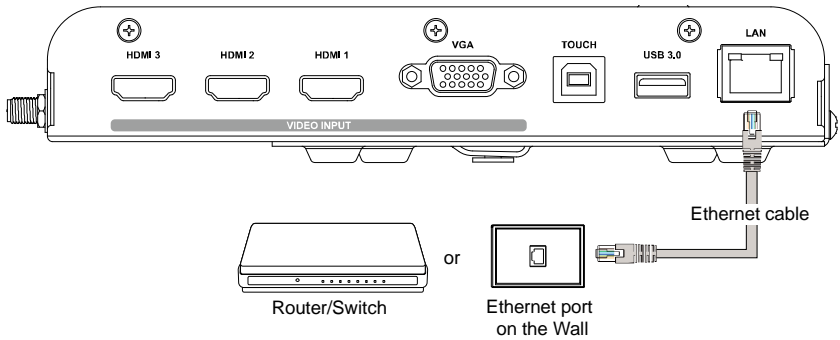

HDMI Output Connection

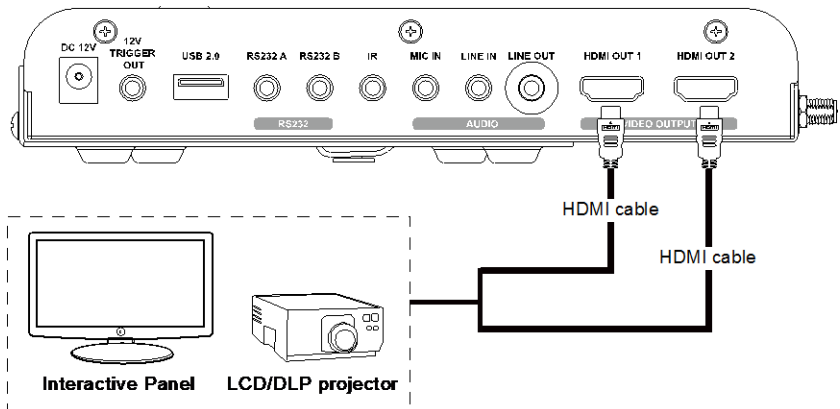

USB Connection

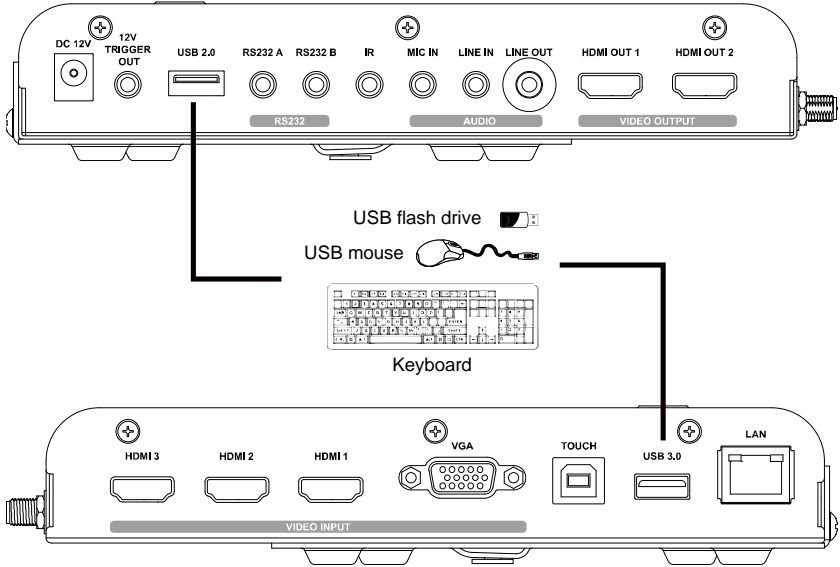

Microphone Connection

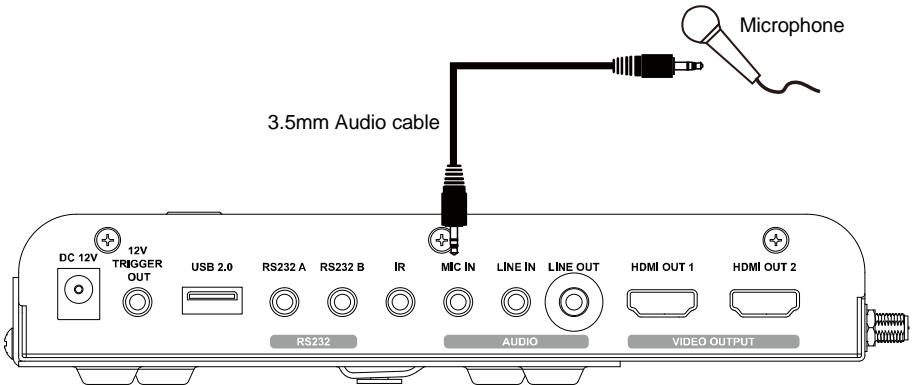

Speaker Connection

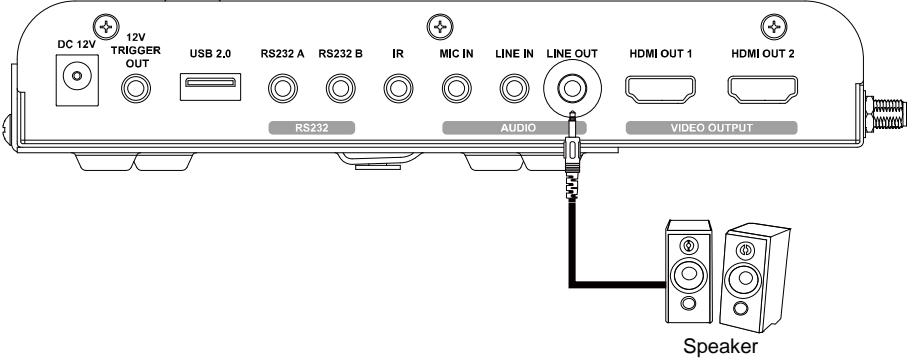

Wall Mount

CB-310 has wall mount bracket included and screwed at bottom of the CB-310 unit. Wall mount bracket allow CB-310 to install on the wall or interactive monitor.

In the following, it will describe how to remove the wall mount bracket from the CB-310 and related installation safety information.

Important Safety Instructions

Improper installation may cause property damage or personal injury. If you do not understand these directions, or have doubts about the safety of the installation, contact Customer Service or call a qualified contractor. AVer is not responsible for damage or injury caused by incorrect installation or use.

After reading the manual, please keep it handy for future reference.

Safety information

Warning

1. The product should be installed by a qualified professional specified by the retail store. Product installation by non-qualified personnel is very dangerous and may cause personal injury.
2. When moving or replacing the product after installation, contact a qualified installer specified by the retail store. Installation or movement of the product must be carried out by a skilled professional. If an unqualified person moves and installs the product, it may cause safety risks.
3. Be sure not to hang the power cable and signal cable on the back of interactive monitor when installing the wall-mounted on the interactive monitor. Damaged cables may result in fire, electric shock, or damage to the product.
4. The product should be installed where its weight can be fully supported. If the product is installed on a weak surface, the product may fall, causing injury.
5. Do not hang on this product; protect the product from severe impacts after the installation. The product may fall and cause injury.
6. This product contains small items that could be a choking hazard if swallowed. Keep these items away from young children.

Caution

1. Follow the instructions in this manual to product properly. If you do not follow these instructions, the product may be installed incorrectly and cause serious injury or the product may become damaged.
2. When installing the product, first check that the wall is flat and strong enough. Use the correct anchor and screws. If you use anchors and screws that are not specified by the manufacturer, they may not hold the weight of the product, causing safety issues.

3. Keep this product away from sprinklers, sensors, high-tension wires and power sources. Do not install it in a location where vibrations or impacts are likely to occur.
4. To install or adjust the height of the product, two or more people are needed. If you try to install or move the product alone, it may fall and cause injury or the product may become damaged.
5. Do not attempt to install or assemble this product if the product or hardware is damaged or missing. In the event that replacement parts or hardware are needed, please contact Customer Service.
6. When drilling holes into the wall, make sure you use a drill and drill bit with the specified diameter. Ensure that you also follow the instructions regarding the depth of the holes. Otherwise, the product may be installed incorrectly and cause safety issues.
7. Do not clean the product with a wet towel, and do not place a heater, or humidifier beneath it. Moisture, steam or heat permeating into this product may result in fire, electric shock or product damage.

Safety tips for installation

1. At least 2 professional installers should on site when installing the wall mounting bracket on the interactive monitor. To prevent injury and damage to the wall and device, user should not perform the installation without professional guidance.
2. The installation position should be on the wall that can bear the weight of the product and bracket, and measures should be taken to calculate the effects of other external forces.
3. To avoid accidental damage to the device and human safety, please install the bracket in a place which avoids the contact of children.
4. When the installed screws become loose, please turn off the device and unplug the power cord for further check.
5. The bracket should be installed on a vertical flat surface.
6. For the best working performance, these places should be avoided: strong electric field, strong magnetic field and potential leakage of inflammable gas.
7. For the best viewing, the bracket should be installed in the place where the direct intense light and reversed light situations should be avoided.
8. In case of fire, please avoid the places as described below : heavy soot, windy and dusty place, intense humidity and intense heat.
9. During installation, please make sure connection between the screws and bracket are secured firmly.
10. This instruction should be strictly followed. The manufacturer isn't responsible for **any damages and lost caused by inappropriate installation and operation.**

Ventilation

Keep clearances around the product according to the minimum dimensions shown in the picture.

Never cover the ventilation holes or insert any object into the housing.

Do not place the product in a confined space such as bookcase or imbedded closet unless appropriate ventilation conditions are provided. There should be adequate clearances around the product to ensure good ventilation.

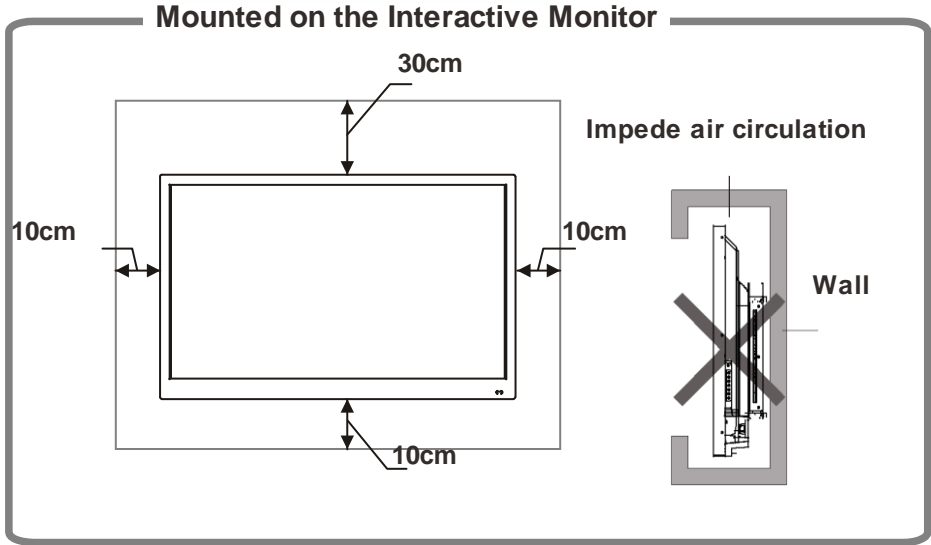

1. First, release the screw at bottom.

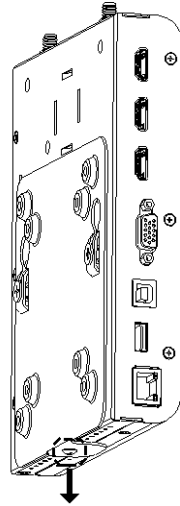

Release the screw

2. Lift the collaboration box and let screw out from the hole on the wall mount to separate the wall mount from the unit.

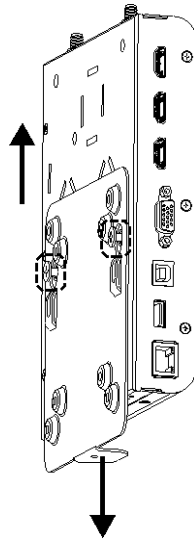

3. Mount the mount bracket on the wall or interactive monitor.
 - On the Interactive monitor: Please use the screw as interactive monitor's spec.

Back side of the monitor

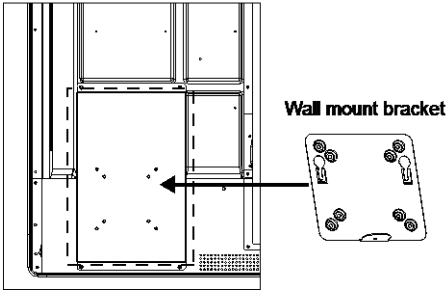

- On the wall: Use the impact drill to drill the holes and use screw to secure the wall mount bracket on the wall.

[Note] Please use the screws according to the actual wall material and condition.

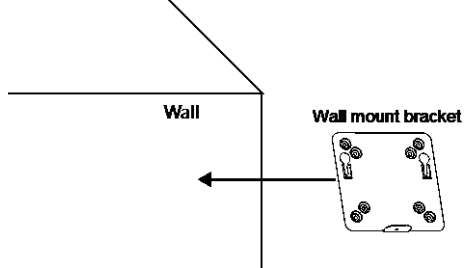

4. Hang the collaboration box on the wall mount bracket.

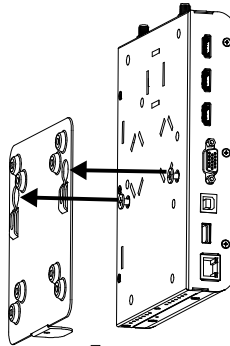

5. Use screw to secure the collaboration box and wall mount bracket.

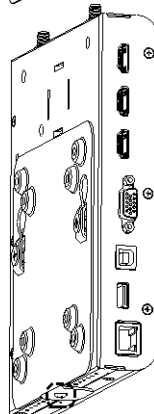

6. Connects all necessary cables. It is recommended to be fixed cables to the wall at about 10 cm from the collaboration box, and then, managed with a cable tie to prevent the cable from falling and pulling the machine.

Using AVer CB-310

Power On

Connect the power plug to the power outlet on the wall. Press the power button () on the AVer CB-310 unit. For the first time startup, a wizard will guide you to setup some settings.

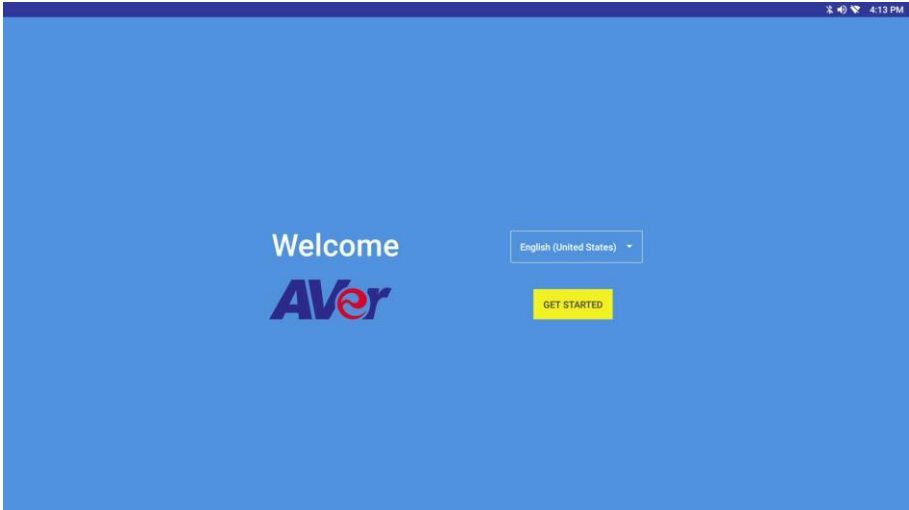

Wizard Setup

For the first time startup, a wizard will guide you to setup some settings.

The following will describe the settings step by step.

1. **Language:** select the language. Tap the ▼ to select the language. Then, tap “**GET STARTED**” to continue.

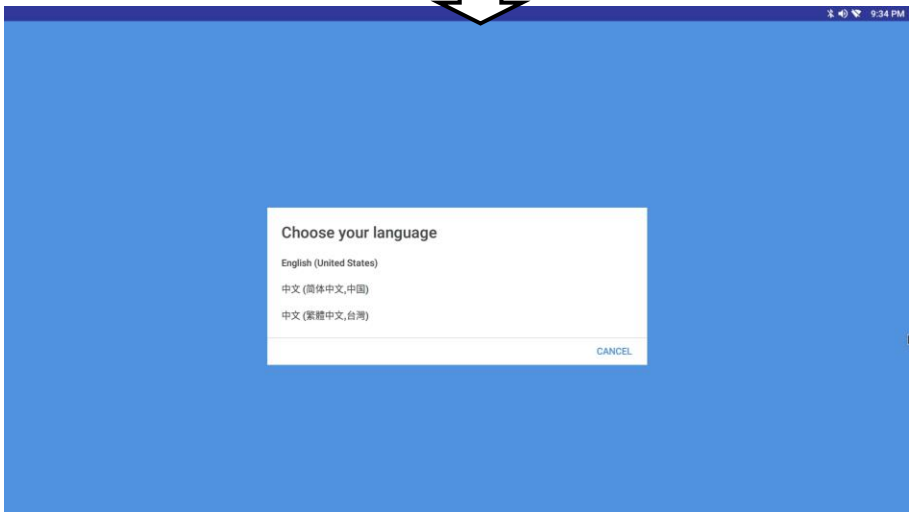
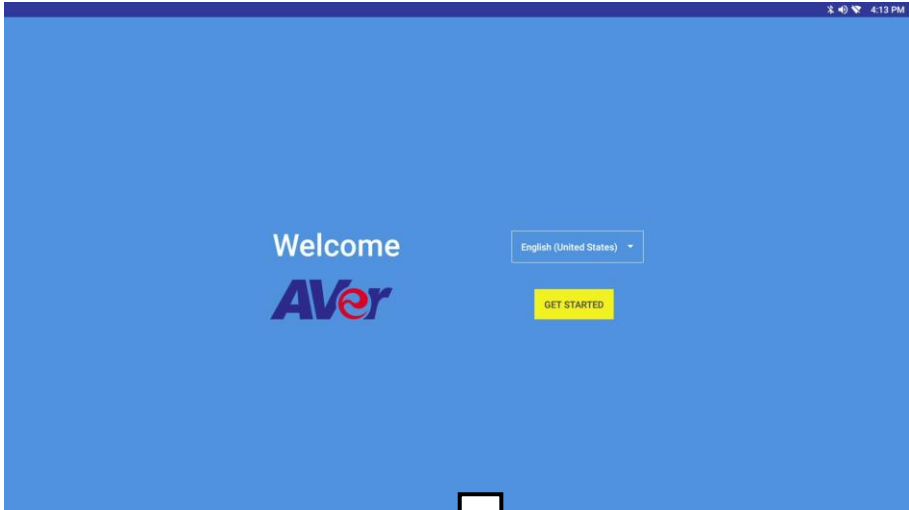

2. **WiFi setup:** Turn on and connect to the WiFi AP. Tap to turn on the WiFi and select the available WiFi AP to connect. If user doesn't enable the WiFi, please remember to connect a Ethernet cable for internet accessing. After connecting the WiFi, tap "Next" to continue.

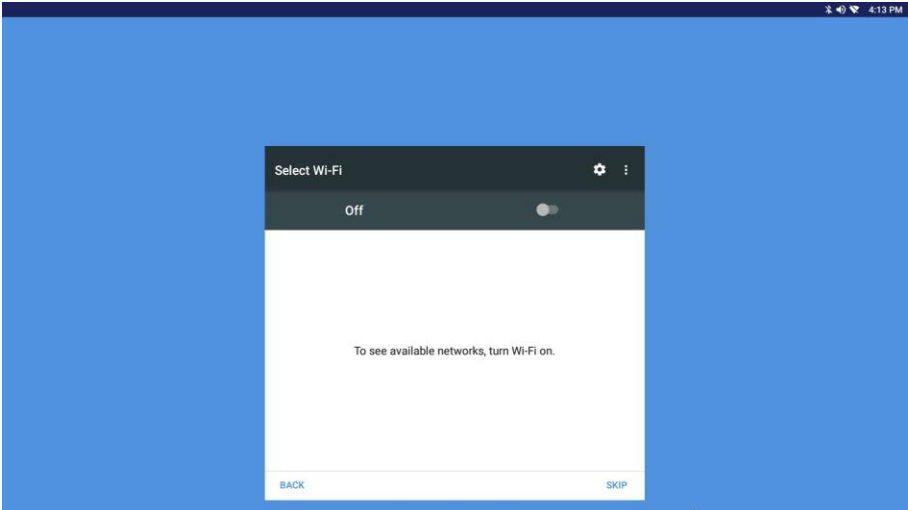

3. **Setup Date and Time:** Set the current date and Time. **Automatically date and time** is enabled in default; but user still can be adjust the **time zone** if needed. Or user can disable the automatically date and time and set the date and time manually. After setting date and time, tap "**NEXT**" to continue.

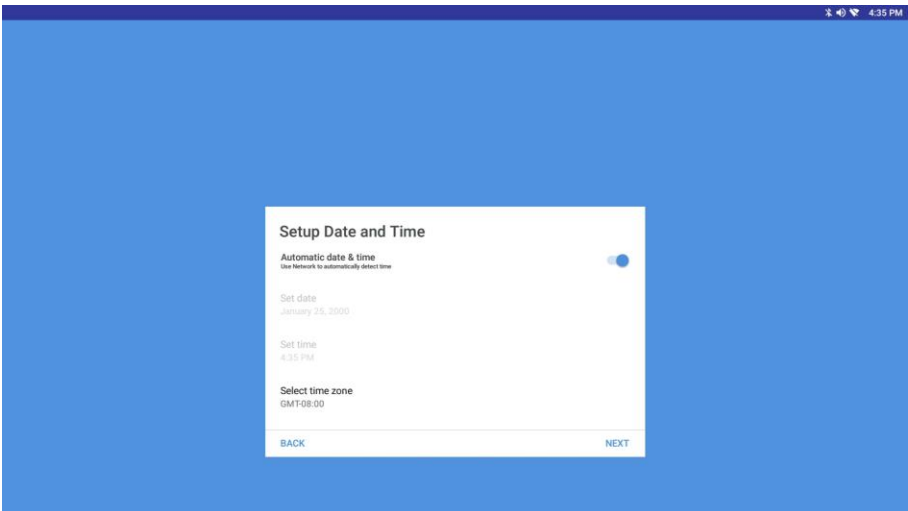

4. **Create Alias for the board:** This name will be used as a Screen Share connection identity. The 20 characters are limited. A default name will be provided by AVer CB-310 system. Select **“SAVE”** to continue and save the settings.

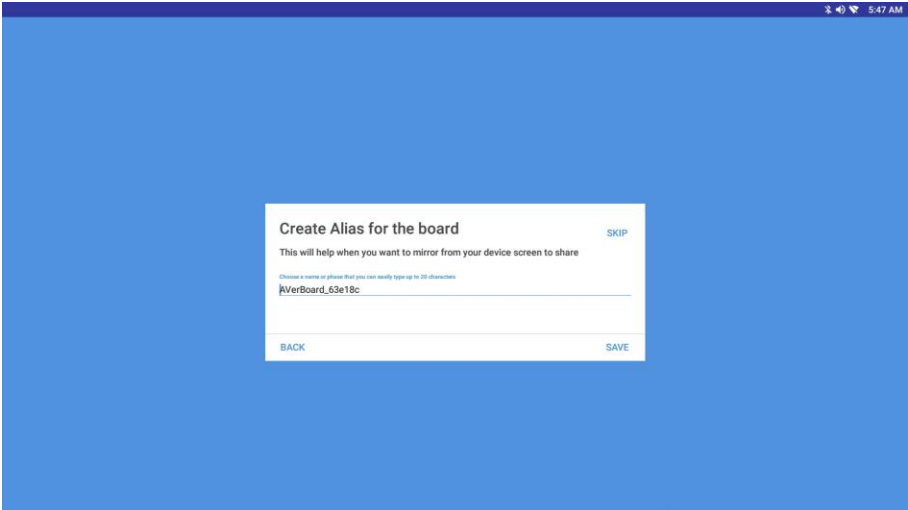

5. **Update FW:** AVer CB-310 system will check if there is a new version FW for updating. If there is a new version FW, the update will be performed. No update, the message will show and tap **“NEXT”** to continue.

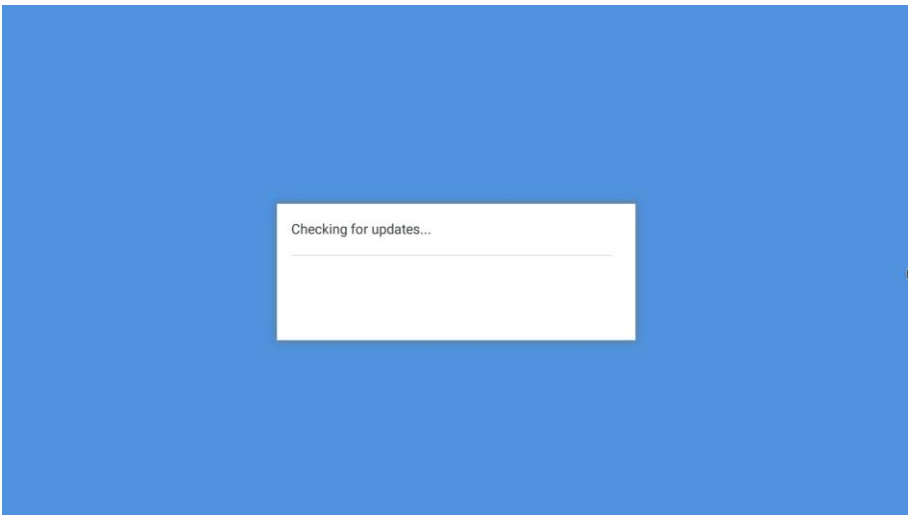

6. **Install Gogole Apps:** Tap "INSTALL" to install apps. After installation, the AVer CB-310 system will restart. If you skip the steps, please download it from the following link.

<https://drive.google.com/open?id=1DQEmDT0L-L0232uGOotAAbigMYuL5vVDt>.

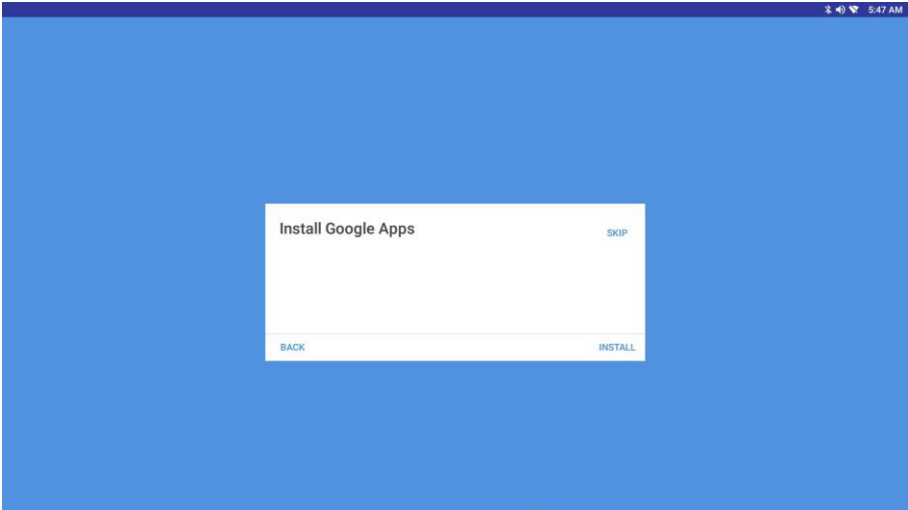

7. **Boot source setup:** Select the input source to display on screen after boot-up (Home screen, HDMI 1/2/3, VGA, USB cam, Screen share, Last input source).

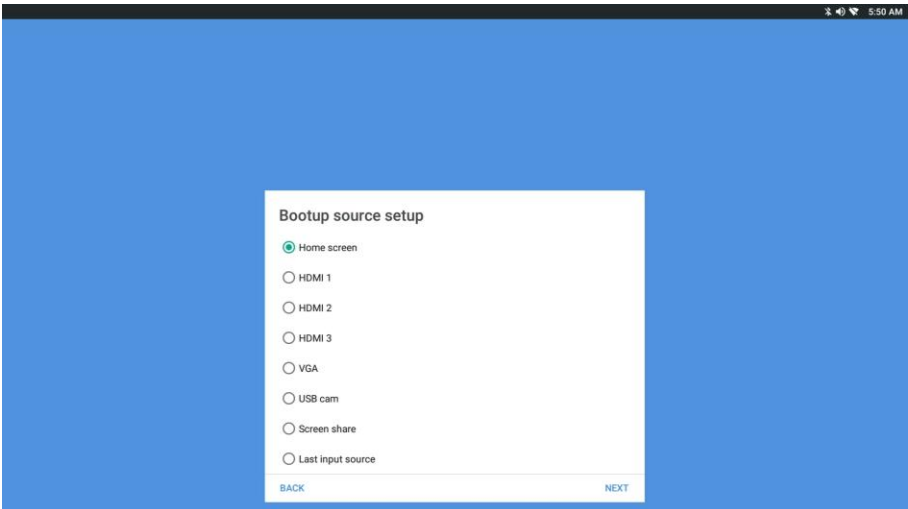

8. **Login:** After restarting, login within your google account. And, the CB-310 system is ready for using. If we want to login later, select “**Skip**”.

[Note] Please make sure the internet connection is working.

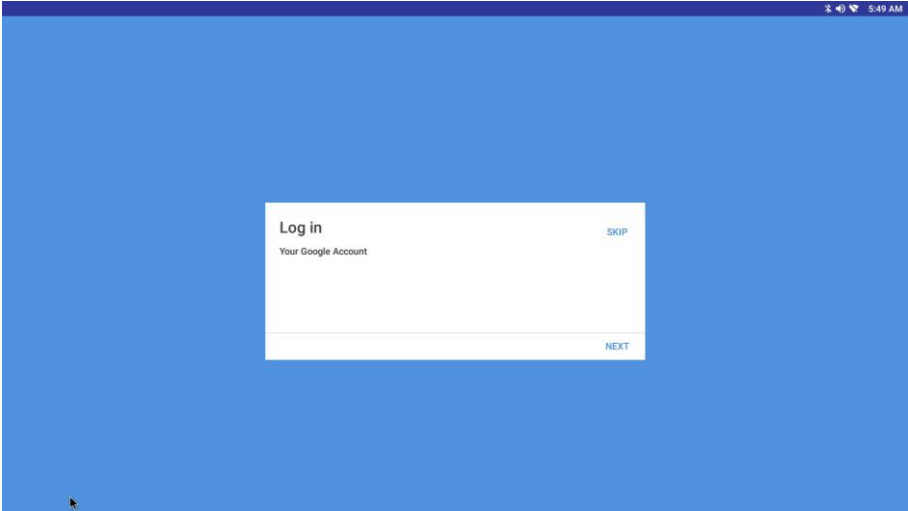

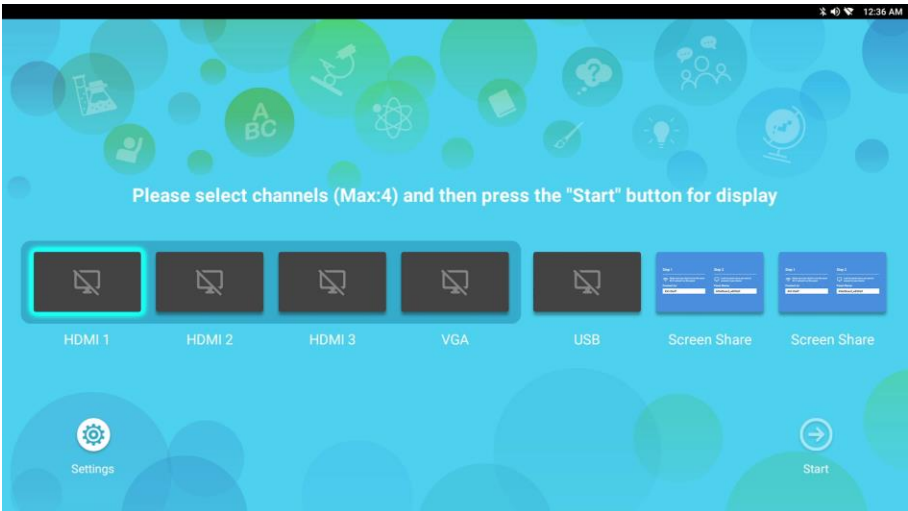

9. After completing the wizard setup, the main screen is displayed. The main screen will be the input source that user selected at “Boot source setup”. The following screen is “Home screen (Entry mode)”.



Power Off

While in power on status, press  >  button on the remote controller to turn off the CB-310.

Also, press power button () on the AVer CB-310 unit, then, the power menu is displayed on screen and select “**Power Down**” to turn off the AVer CB-310 system. Also, user can long press power button () to turn off the AVer CB-310.

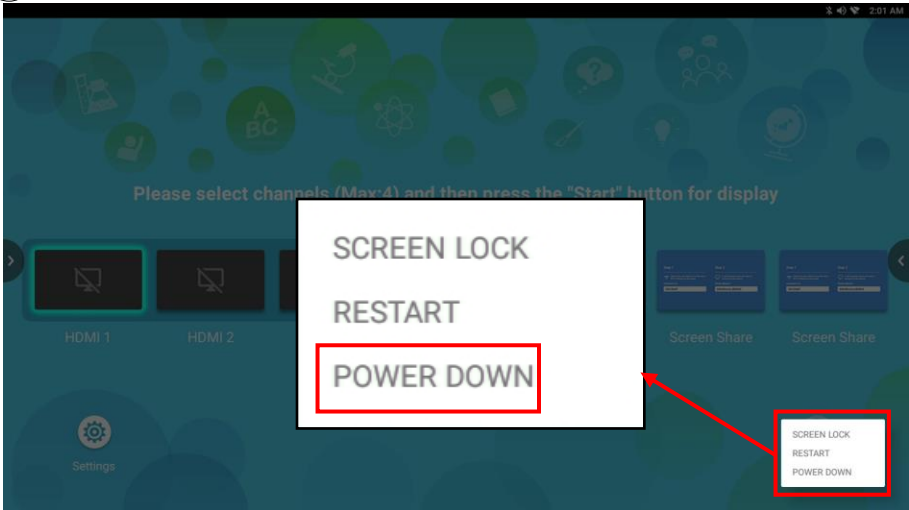

Restart

Press power button () on the AVer CB-310 unit and select “Restart”.

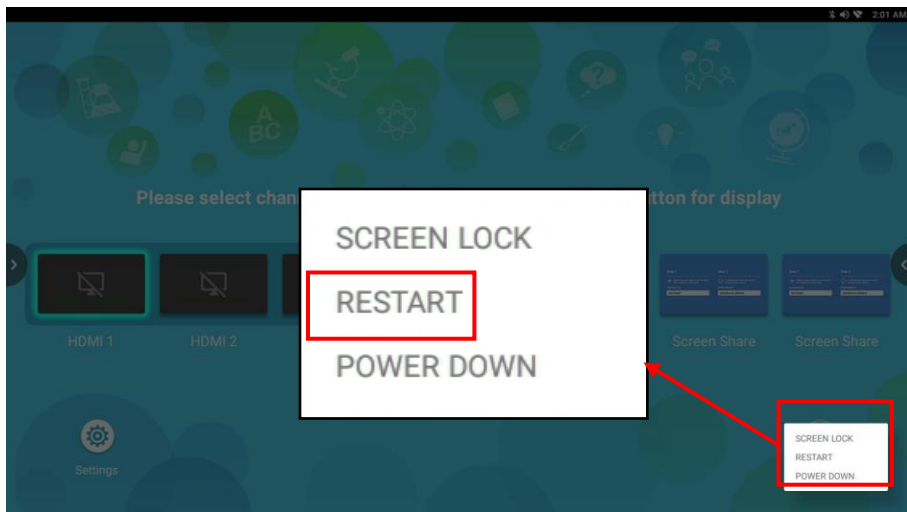

Screen Lock (Manually)

User can manually turn off backlight.

1. Press power button on the AVer CB-310 device.
2. Select “**SCREEN LOCK**”. The screen will turn to black immediately.
3. While in backlight off status, press power button can bring out the screen.

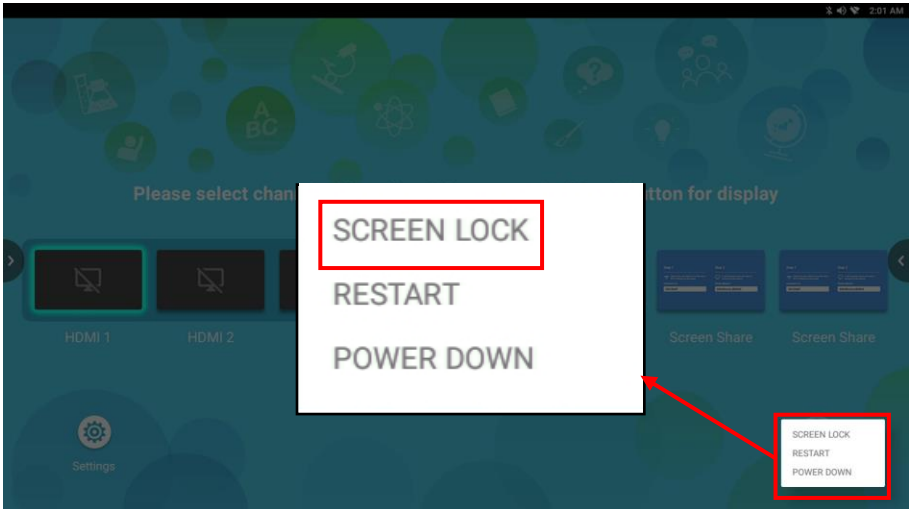

Mode Switching

AVer CB-310 provides two modes – Entry and Advanced mode. The default is Entry mode.

Press  button to switch between Entry and Advanced mode.

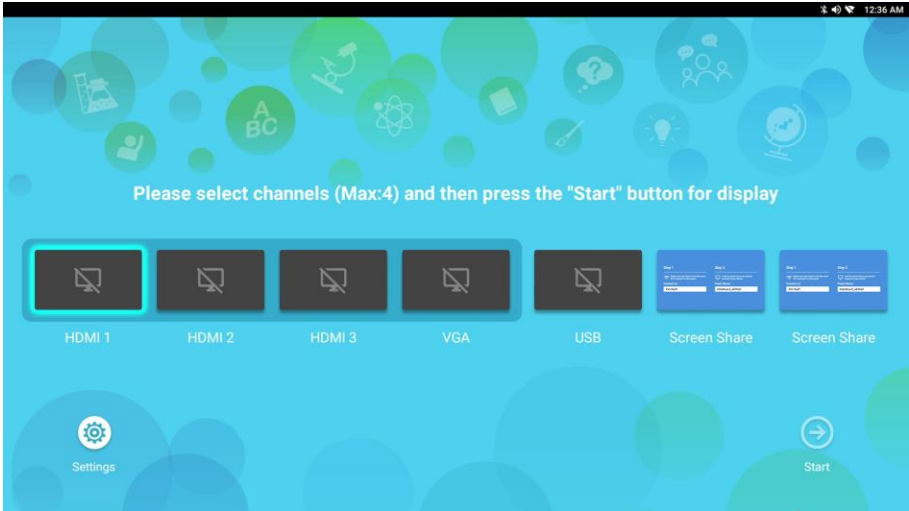

Entry Mode

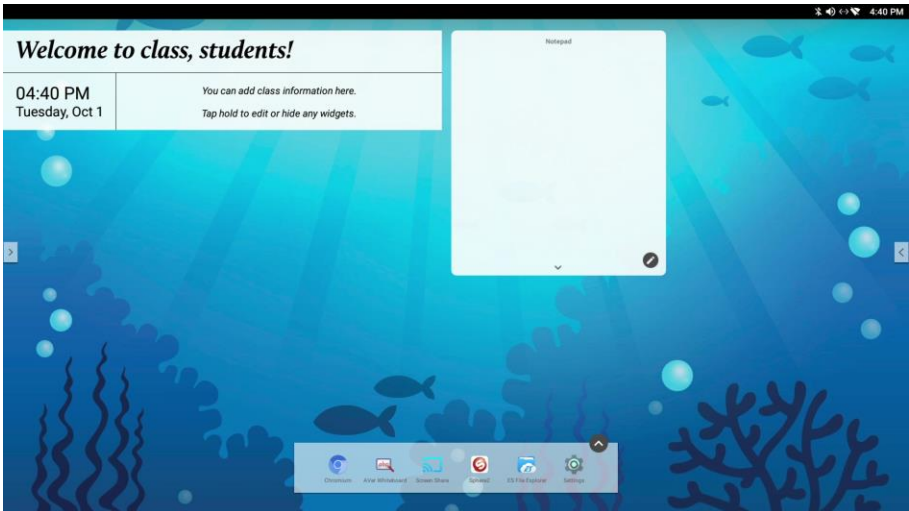

Advanced Mode

Entry Mode

At Entry mode, user can select multiple input sources and Screen Share function. The maximum multiple screen are up to 4. Input source HDMI 1/2/3, VGA only can select one; the Screen Share screen can select two.

Press ◀ and ▶ button on remote controller can select input source. Press **OK** button to confirm the selection.

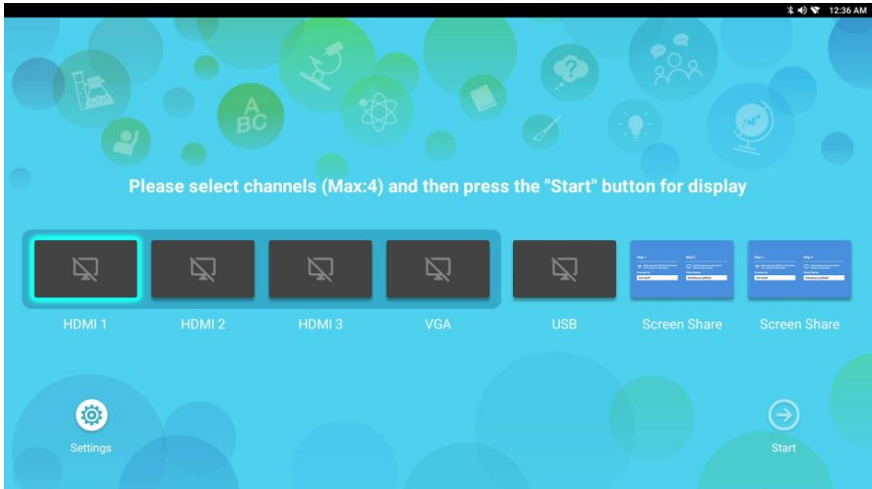

After selecting, press ▼ button move to "Start" and press **OK** button. Then, screen will switch to selected screen view.

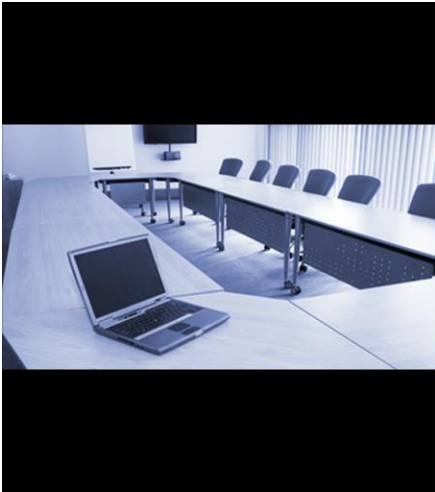

Step 1

 Make sure your device is on the same Wi-Fi network as this panel

Connect to:

Step 2

 Look for panel name you want to connect in your device

Panel Name:

In input source screen (HDMI 1, 2, 3 or USB), press **OK** button on the remote controller will show up the control icon (⬆️⬇️⬇️⬆️) on screen. Use Zoom in/ out((⊕/⊖)) button on remote controller to operate. Also, press ▲, ▼, ◀️, ▶️ button and move the image view on the screen. Press **OK** 鍵 again can switch to full screen view.

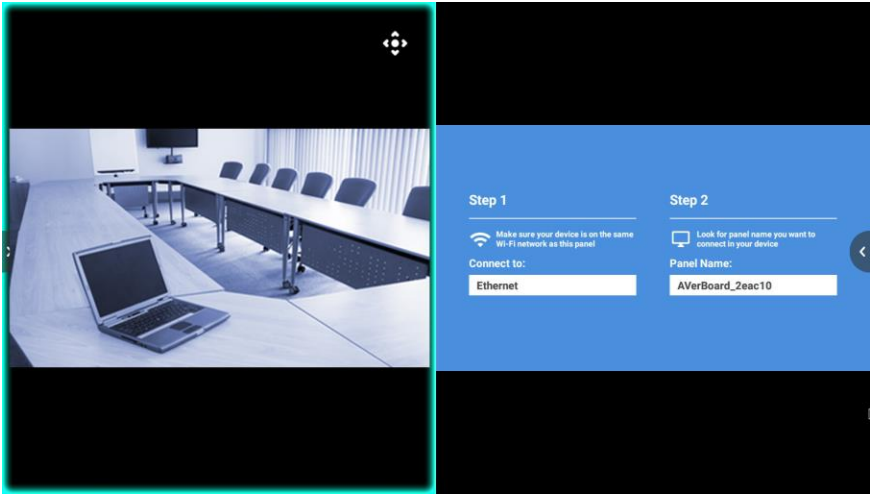

Press **⏪** button on remote controller can select different input sources. If user wants to cancel the previous selection, use ◀️ and ▶️ button move to the input source and press **OK** button to un-select. When changing the input source, the screen view is stop. Press **HOME** button can return to main screen.

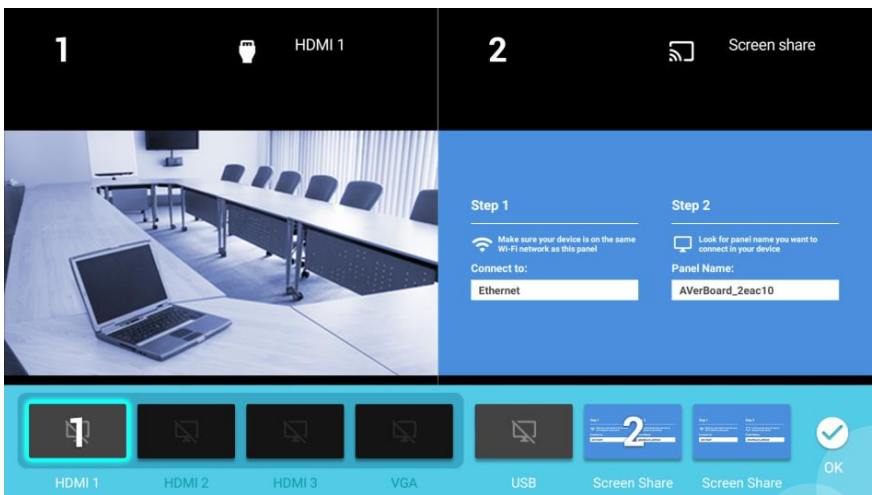

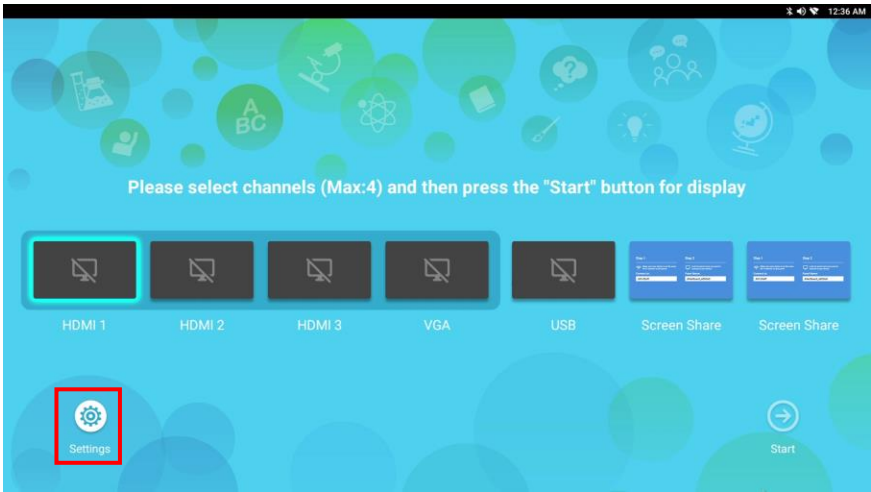

Select "Settings" will call out setup page.

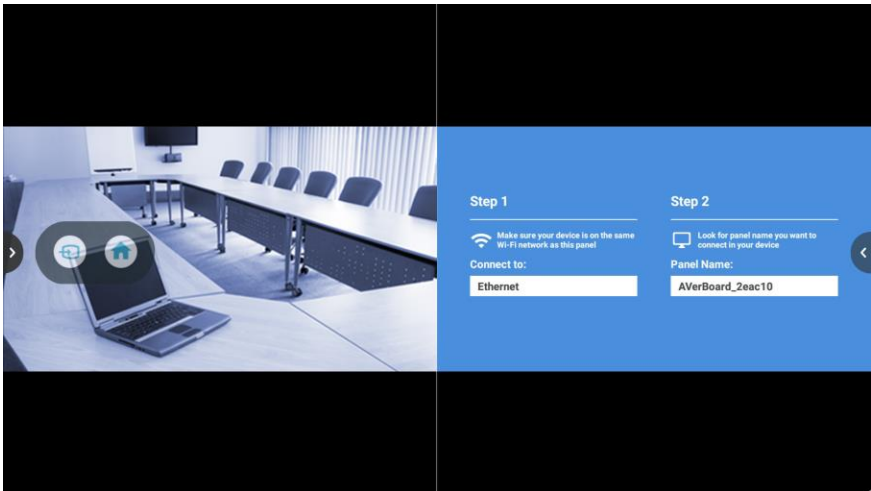

Tool menu

To call out tool menu, please connect the USB mouse to the AVer CB-310. Then, select  to expand menu.



Select  can change the selected input source. Select  will return to home screen view.

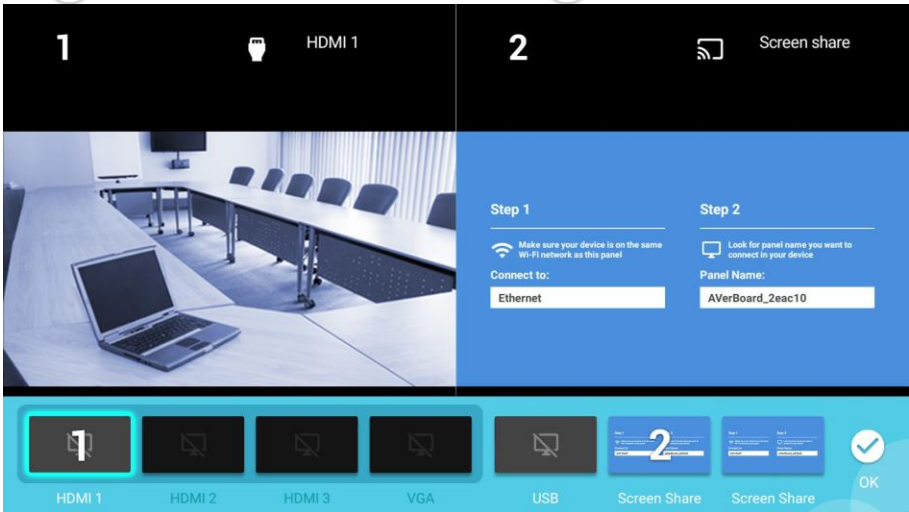

Enable Airplay Onscreen Code

Enable/disable the AirPlay code to display on screen for Apple device connection.

Please connect the USB mouse to the AVer CB-310 to operate the function.

1. Select 「**Settings**」.

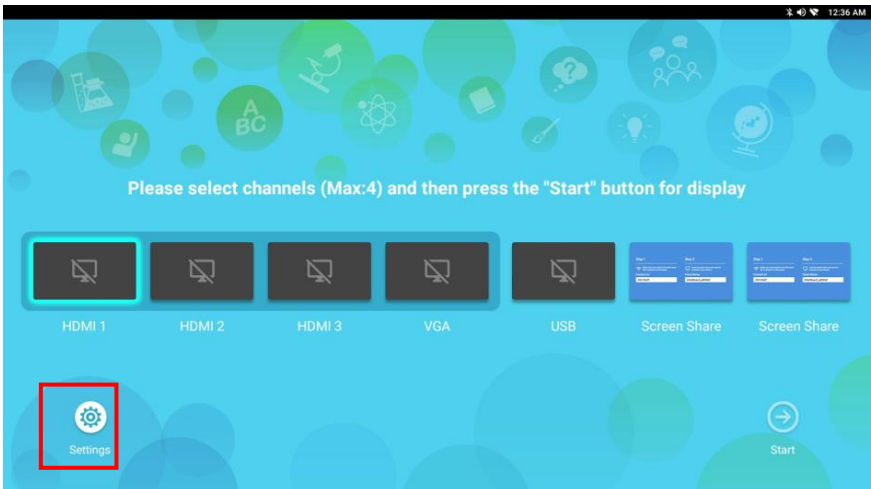

2. Select AirPlay Onscreen code to on status.

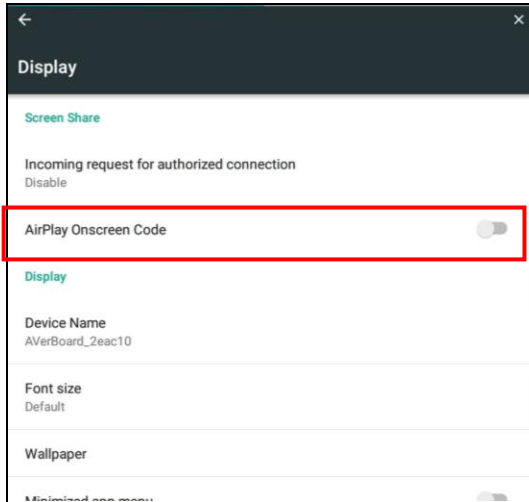

3. The Airplay code will display on Screen Share screen.

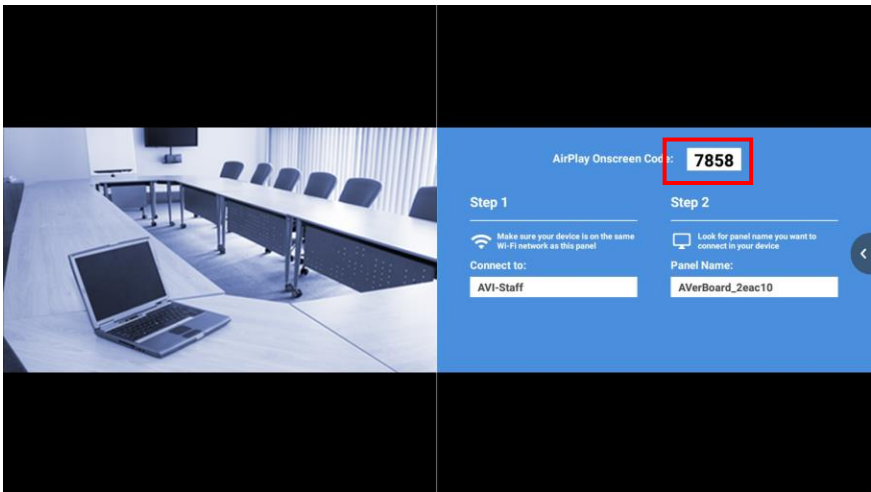

4. When two Screen Share are displayed, the Airplay code is same.

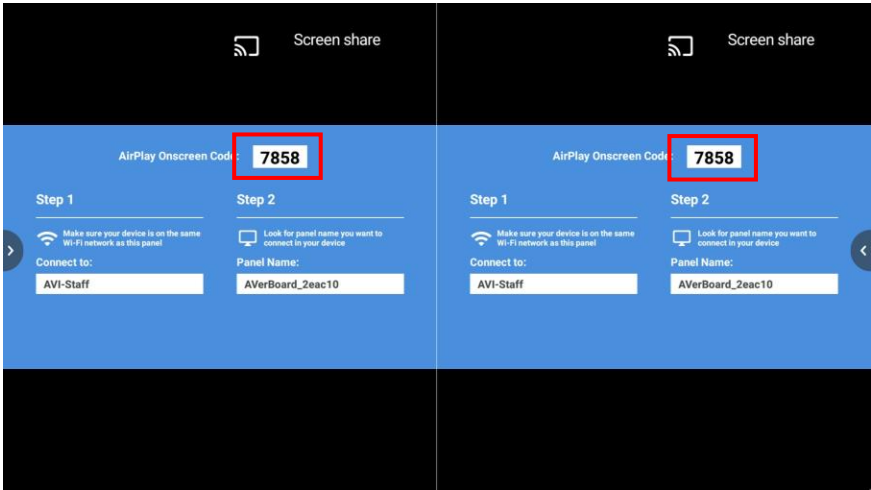

Advanced Mode

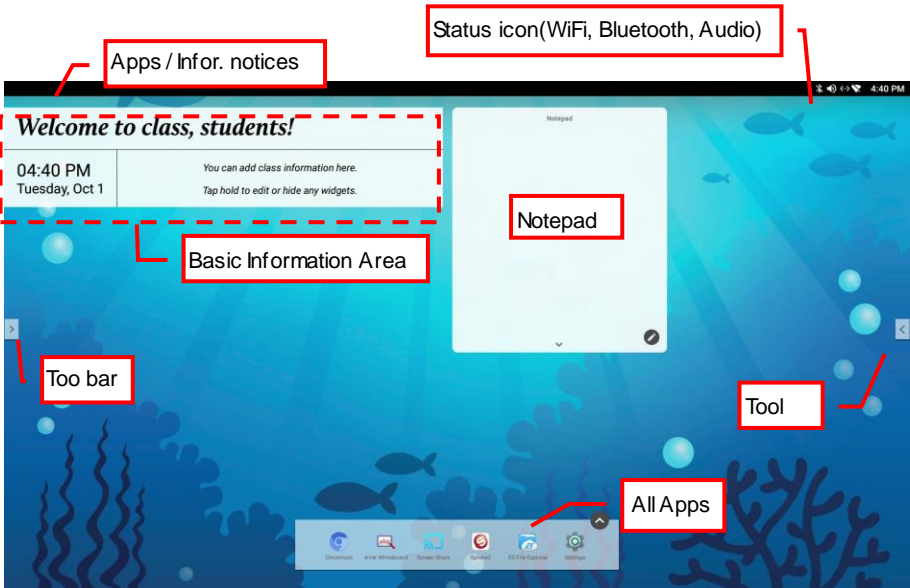

- **Basic Information:** User can define Headline, Secondary Information and Time & Date(Also see [Basic Information](#) section).
- **Notepad:** User can write the memos in here (Also see [Notepad](#) section).
- **Tool bar:** Select or to call out tool bar. Tool bar are include Back, Home, Annotate, App Switch, and Inputs functions (Also see [Tool bar](#) section).

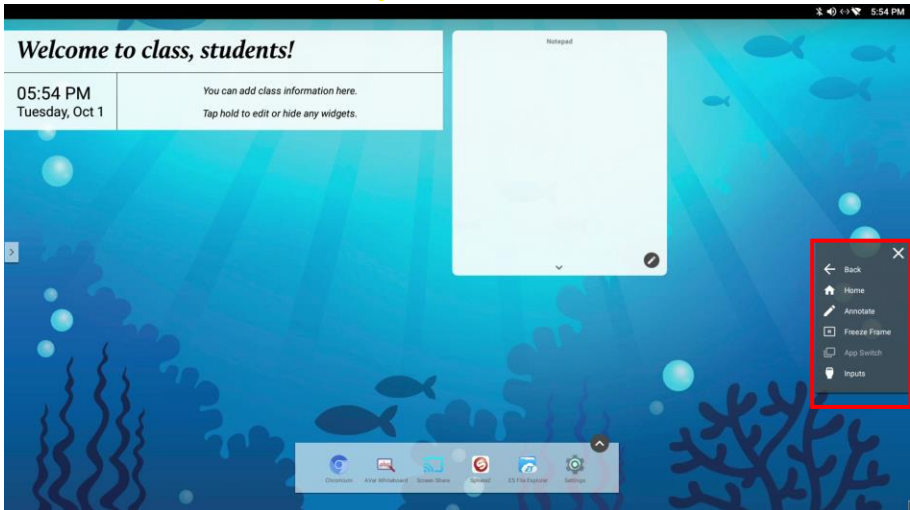

- **All apps:** All application programs in the system are displayed in here. Select  to expand app list. Tap and hold on the app can move app's position. If app is installed by user that can be deleted; Tap and hold on the app and an "X" will show on app.

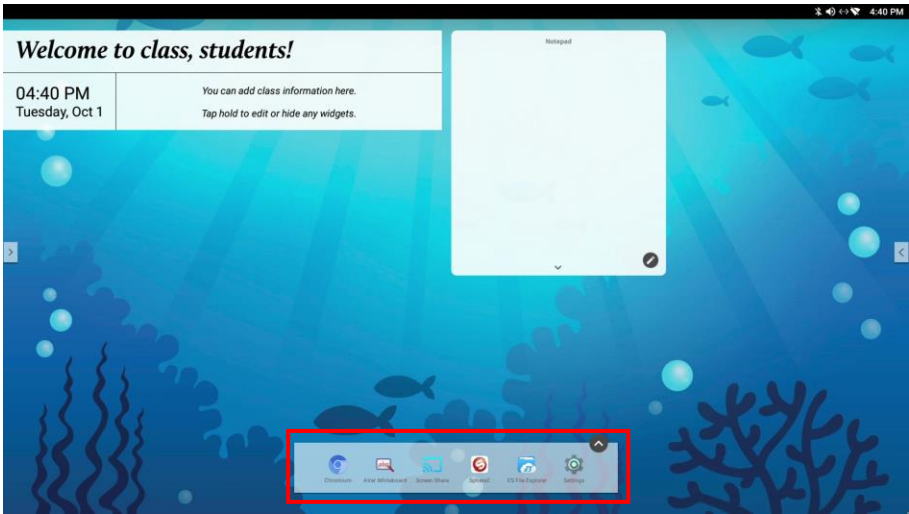

Click  to narrow down the app list.

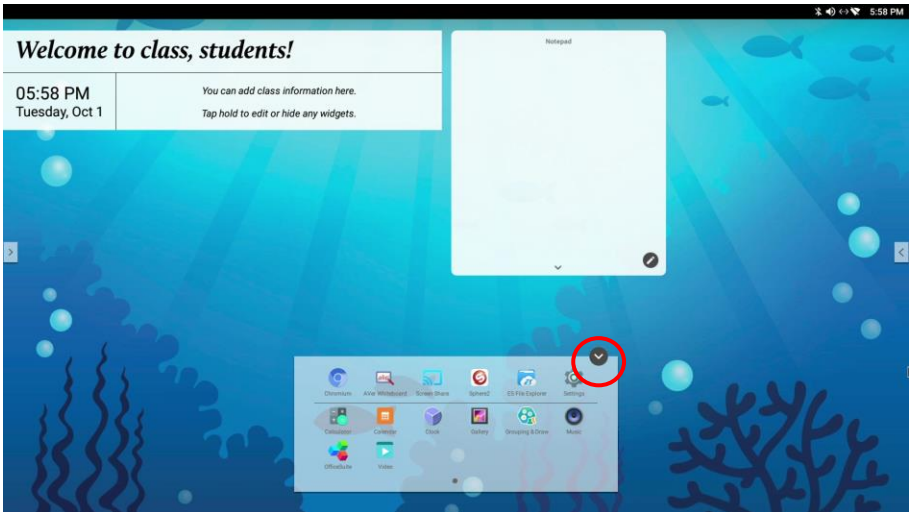

Application icon can move to the desktop.

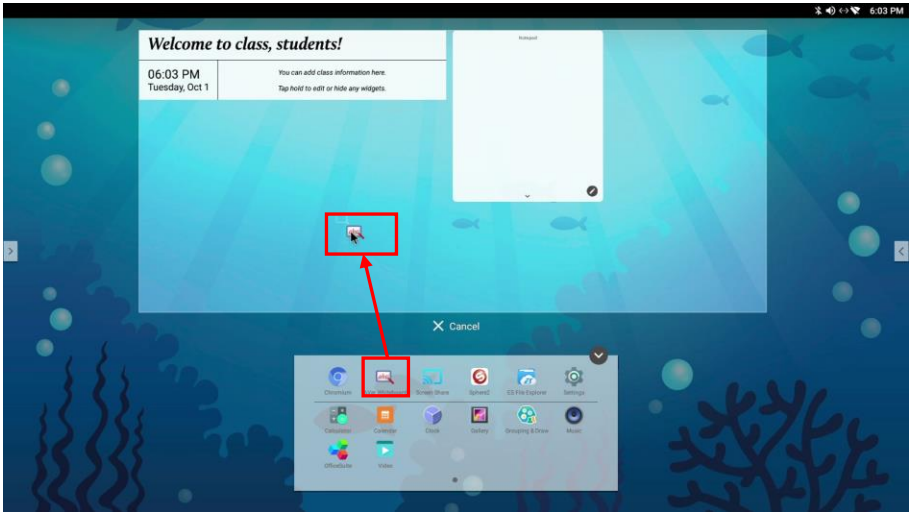

To delete the App icon from the desktop, click and hold until "Remove" option is shown. Then, move the App icon to remove option.

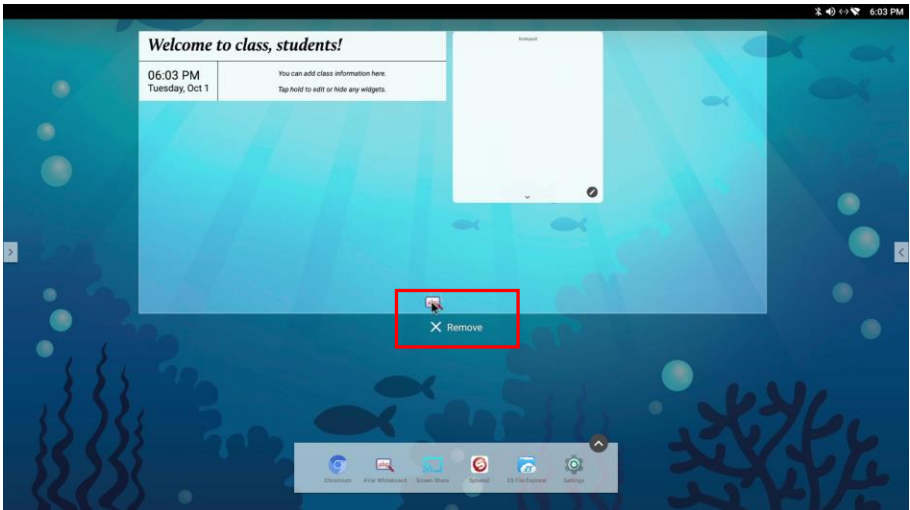

Multiple Apps can create a file folder on the screen. First, move the one app to the screen and move another app over the app. Then, a file folder will be created. The file folder can be re-named as user wants; just select and enter the name.

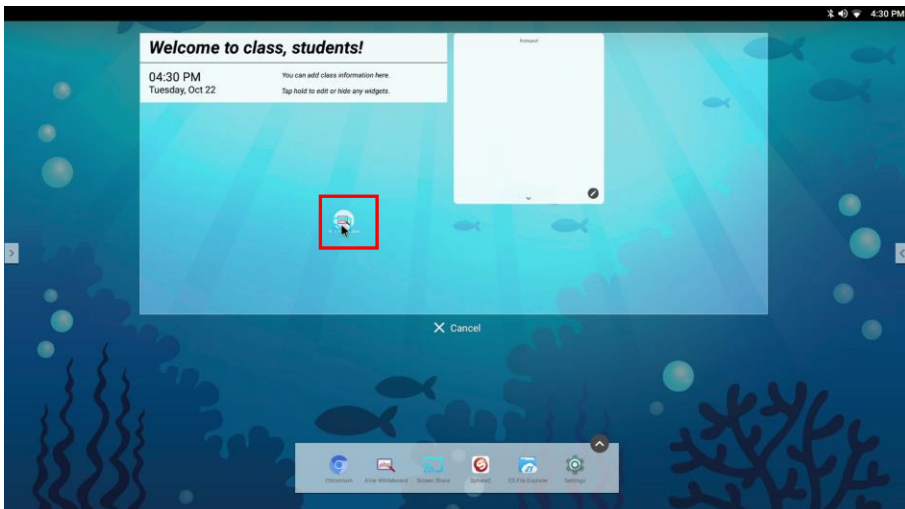

The file folder can be re-named as user wants; just select and enter the name.

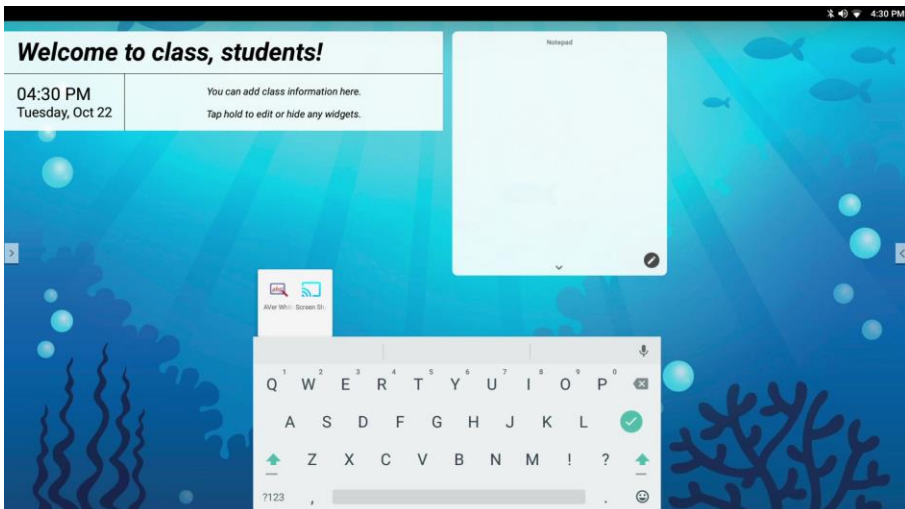

To delete file folder, click and hold until “**Remove**” option is shown. Then, move the file folder to remove option.

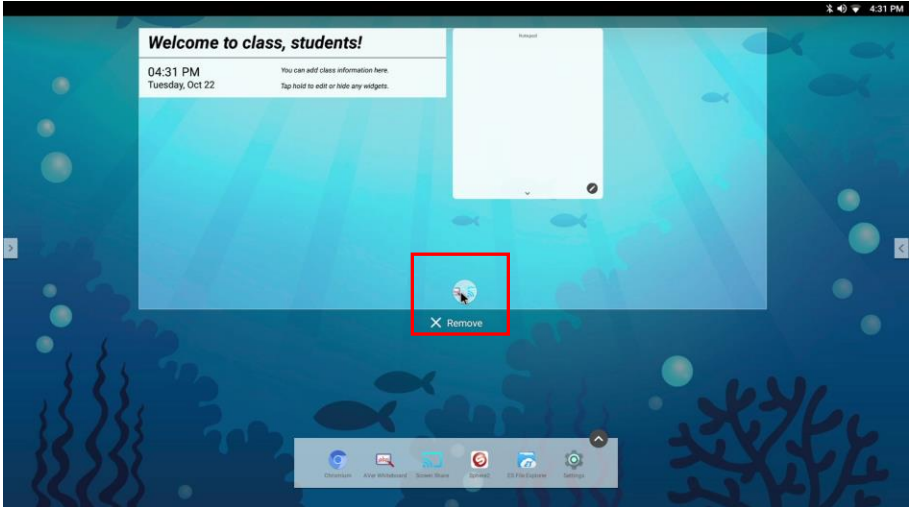

- **Notice column:** Wipe from top to down the notice column will display. The notice column display the current action that user has done and some reminders. Select “**CLEAR ALL**” will delete all notice in column.

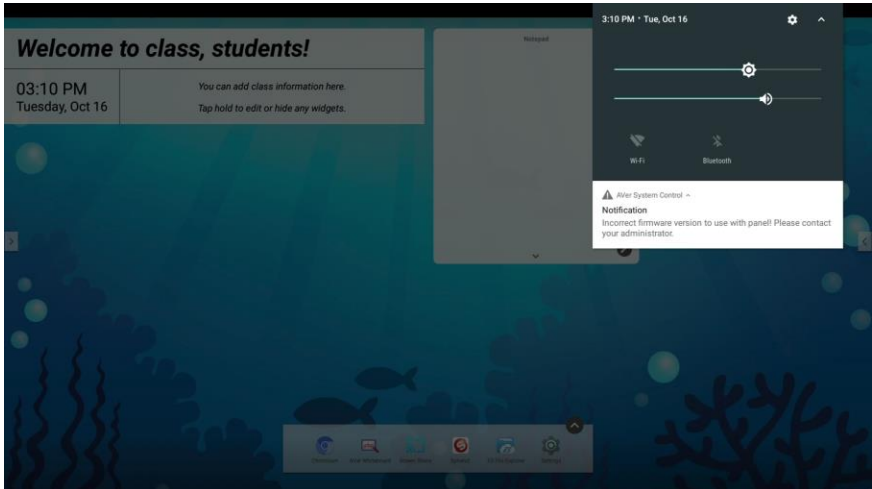

- **Status icon(Bluetooth, WiFi, Audio)** : Tap to display WiFi and Bluetooth status icon. Tap icon can enable/disable the status. Tap “v” to expand the column for volume and backlight adjust bar.

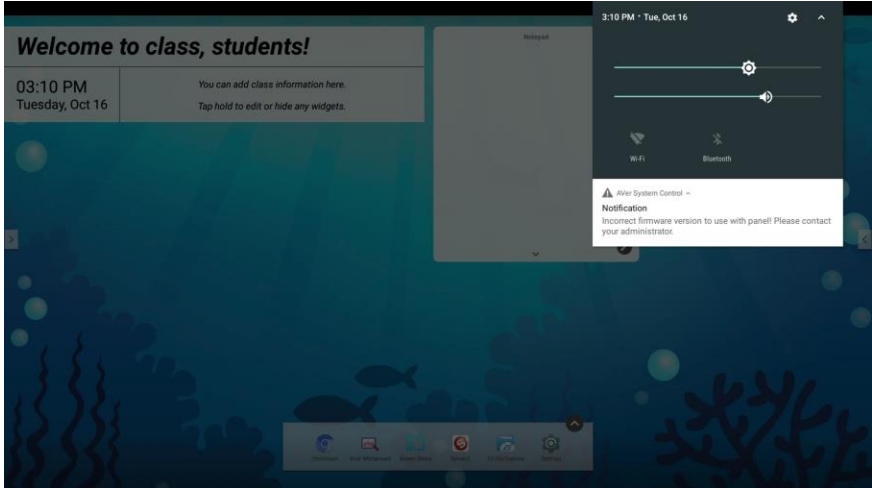

Basic Information

User can define the Headline, Secondary Information, and set Date&Time on/off on the main screen.

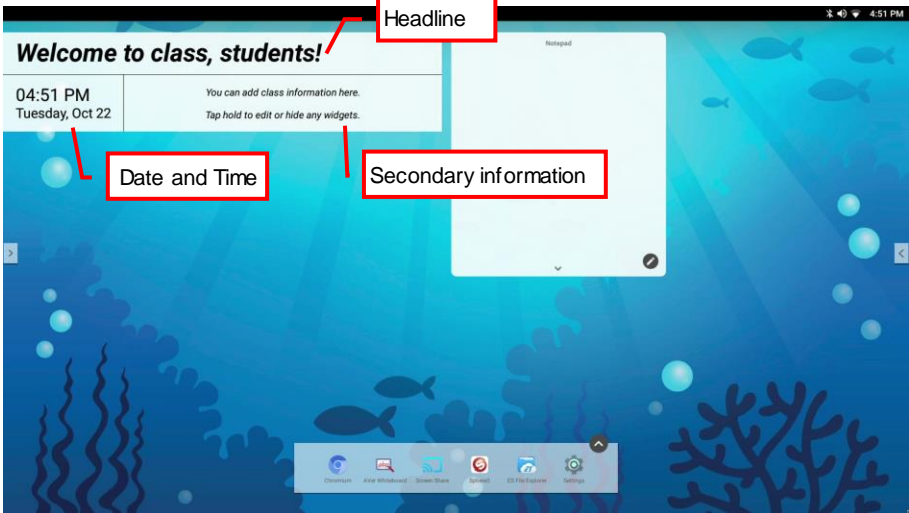

Edit the Basic Information

1. Click and hold the Basic Information to edit.
2. Select "**Edit content**".

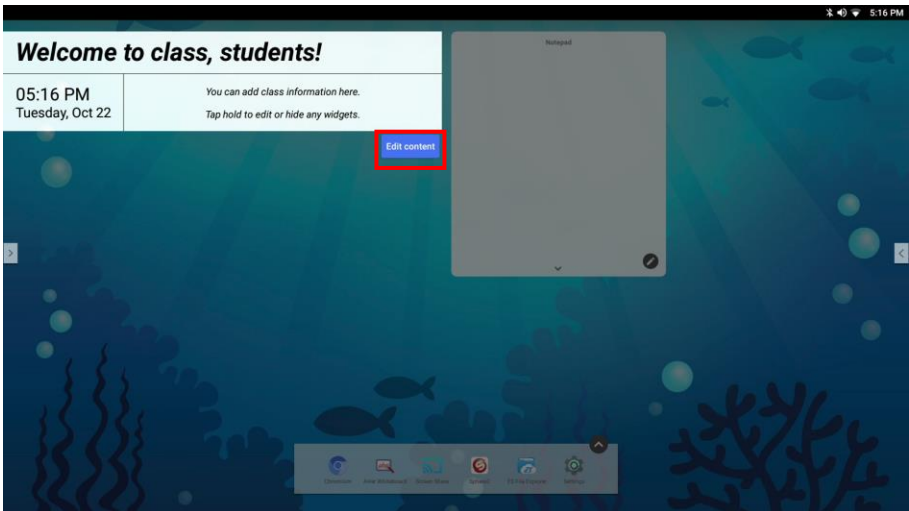

3. In Basic Information dialog, user can select **Headline**, **Secondary Information**, and **Time and Date** to display on main screen or not. Just click  to on or off the displaying.

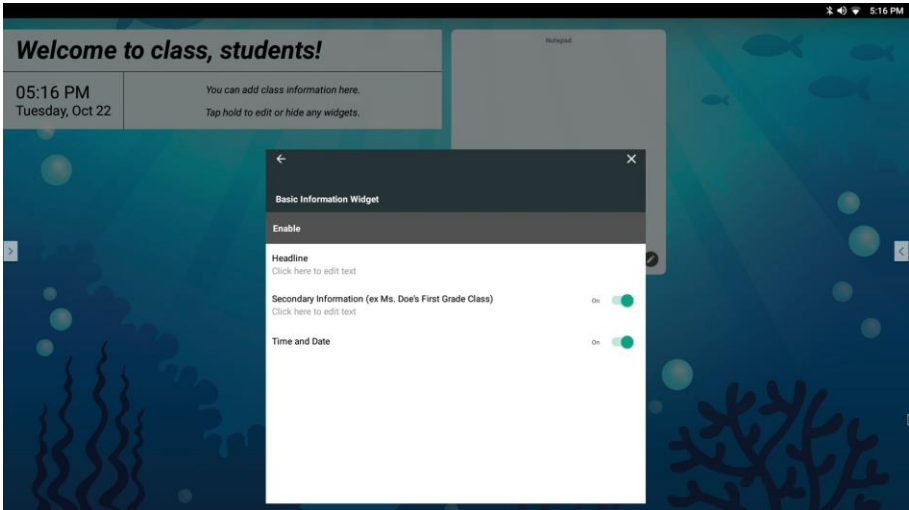

4. After setting, the headline, secondary information and time and date are displayed.

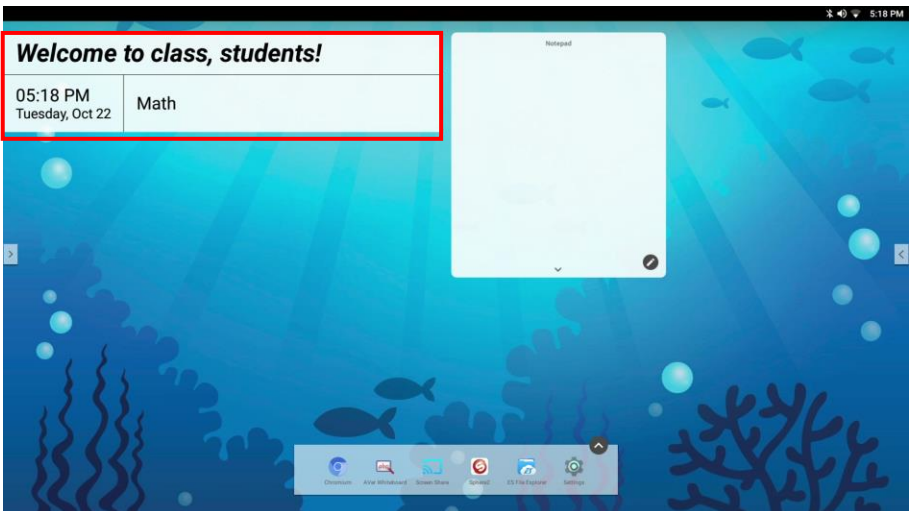

Disable the Basic Information

Don't display the Headline, Secondary information and Time & Date on the screen.

1. Click and hold the Basic Information until the “**Remove**” option is shown.
2. Move the Basic Information to the “**Remove**” option. Then, the Basic Information will be disappeared from the screen.

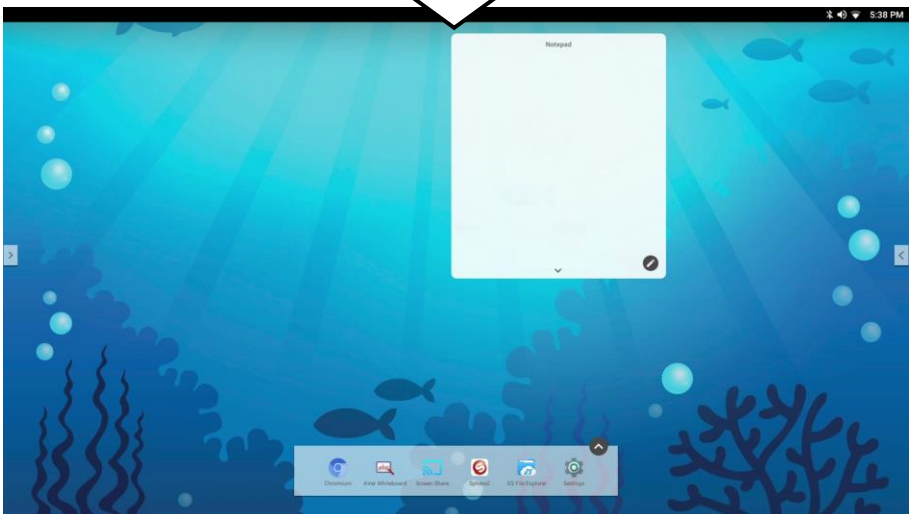
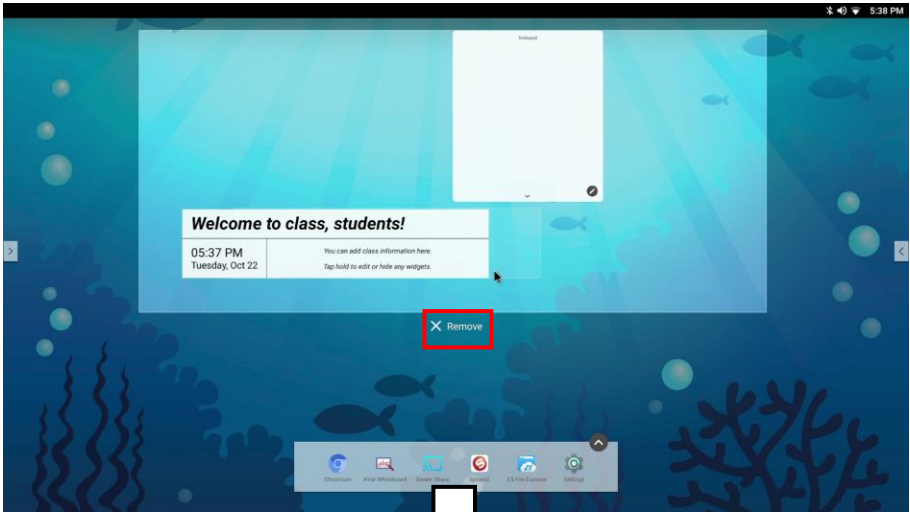

Enable Basic Information

1. Click and hold the screen until the “**Widgets**” option is shown.
2. Select “**Widgets**” and select and drag the “**Aver Basic Information**” to the screen.

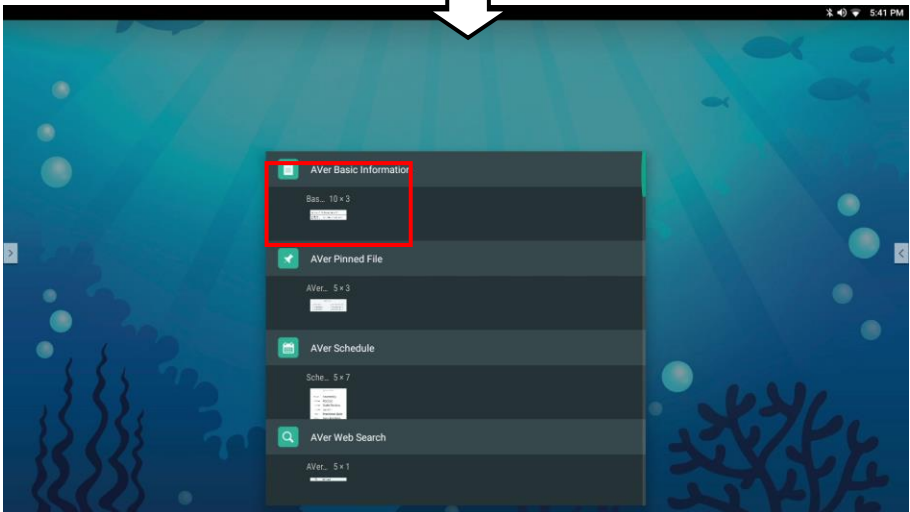
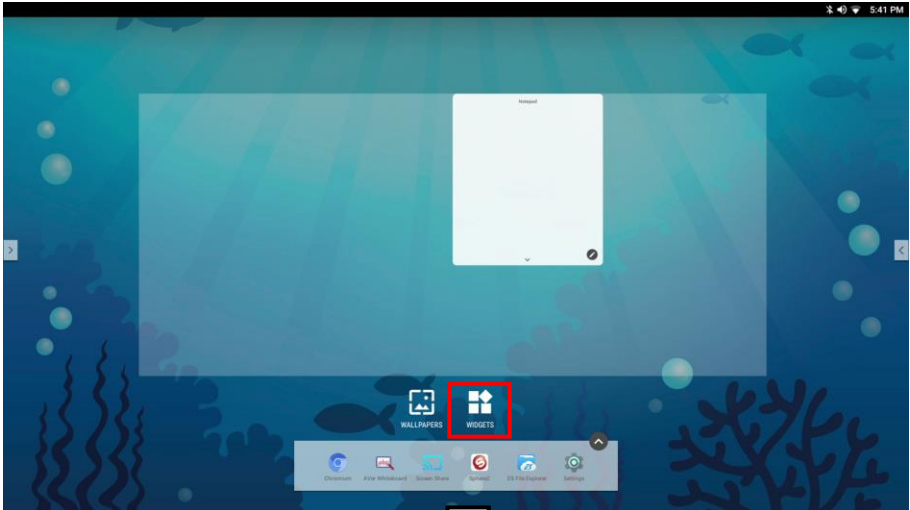

Notepad

User can write memos on the notepad.

1. Click “” switch to edit mode.

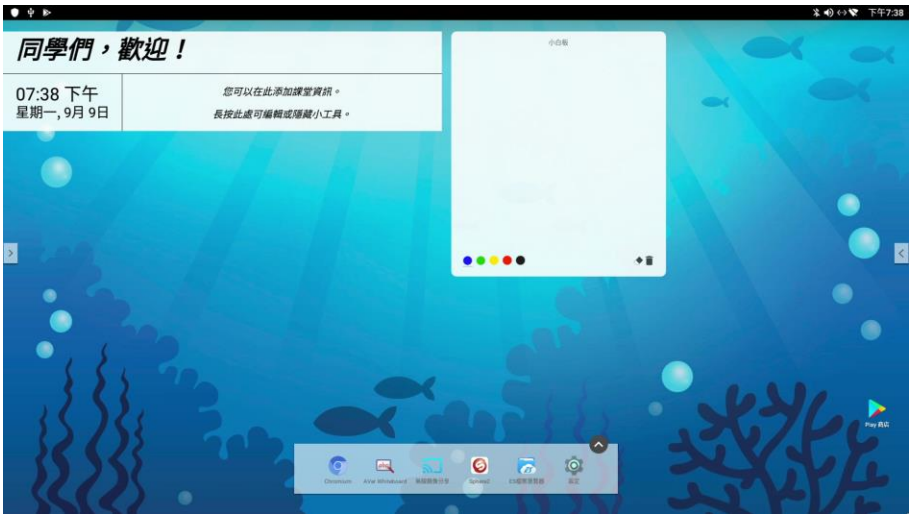

2. Select the color and write on the notepad. For partial deletion, select “”. To delete all, select

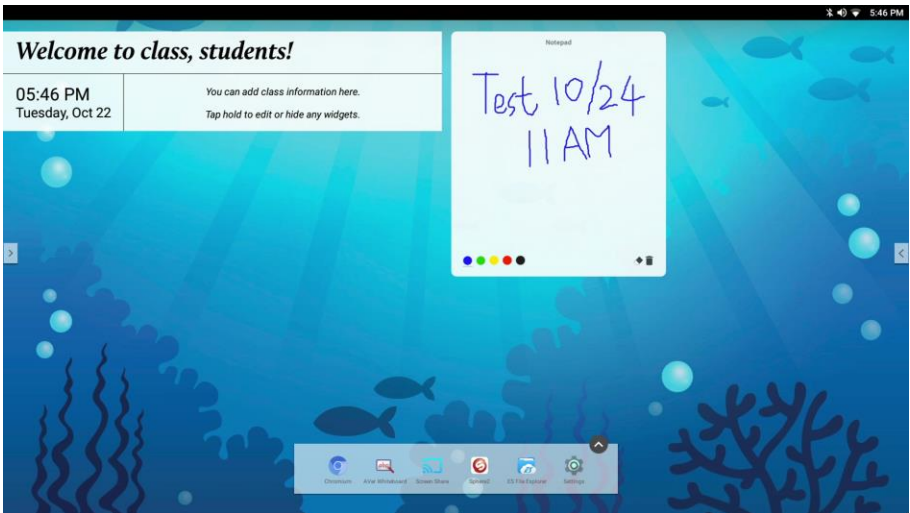

3. Tap “v” can expand more space. Then, select “” switch to edit mode.

Disable the Notepad

Don't display the Notepad on the main screen.

1. Click and hold the Notepad until the “**Remove**” option is shown.
2. Move the Notepad to the “**Remove**” option. Then, the Notepad will be disappeared from the main screen.

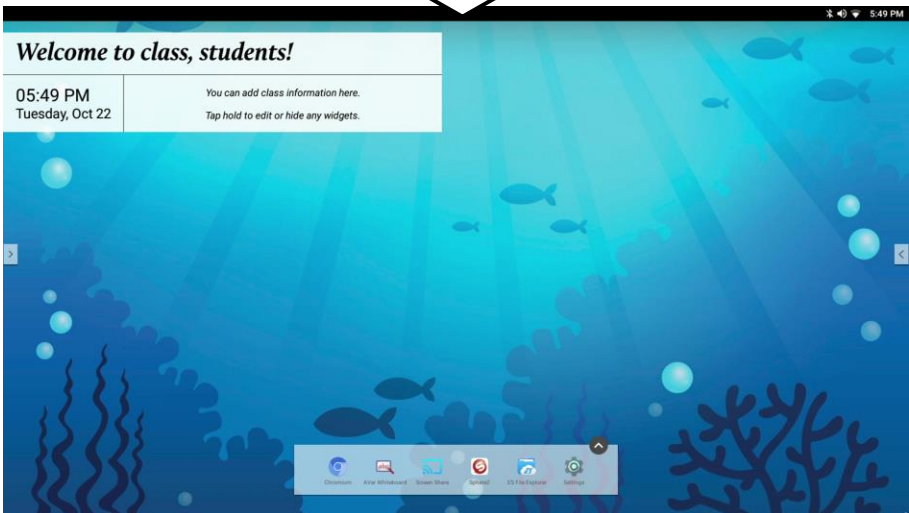
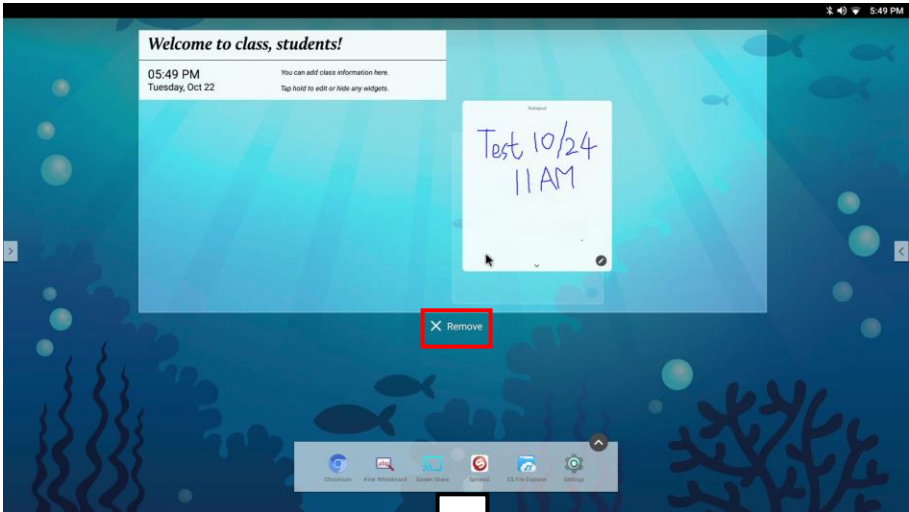

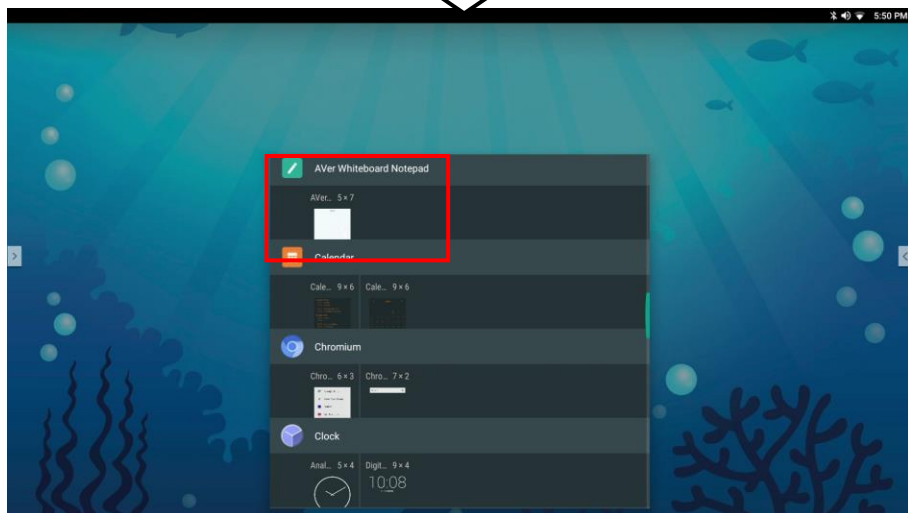
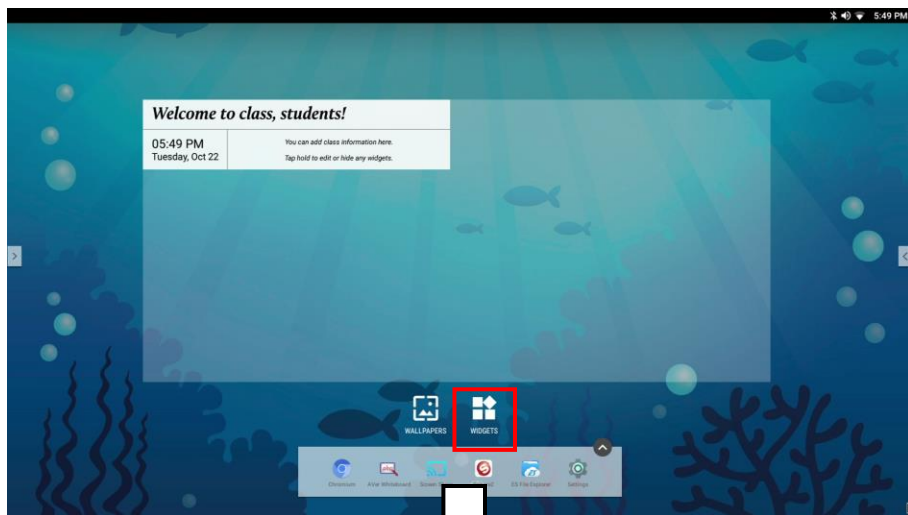

Enabel the Notepad

1. Click and hold the screen until the “**Widgets**” option is show n.
2. Select “**Widgets**” and select and drag the “**AVer Whiteboard Notepad**” to the main screen.



Schedule

User can set the class time to remind. The in time class will be in **bold text**. To view other schedule page, tap  and  to switch it.

Edit the Schedule

1. Click and hold the screen until the “**Widgets**” option is shown.
2. Select “**Widgets**” and select and drag the “**Aver Whiteboard Notepad**” to the main screen.

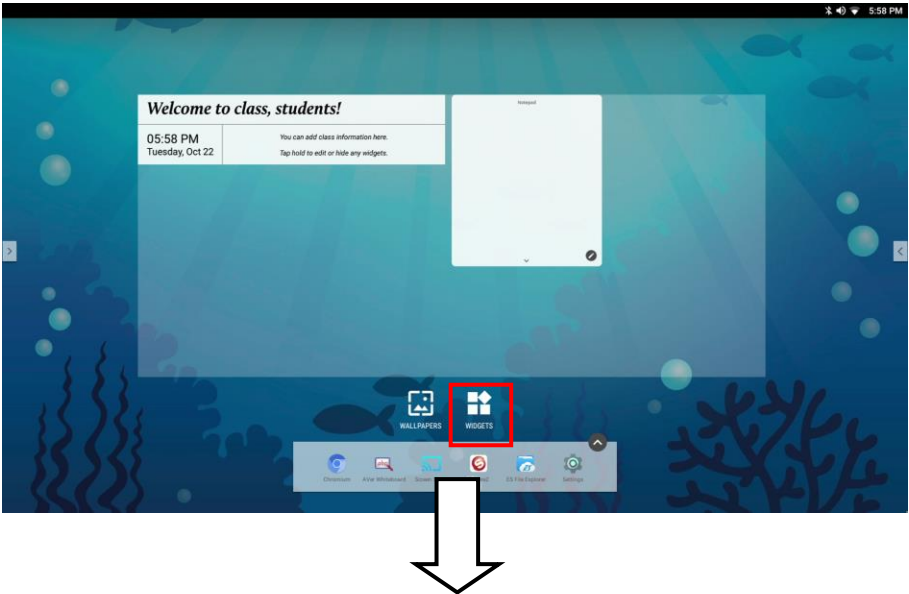

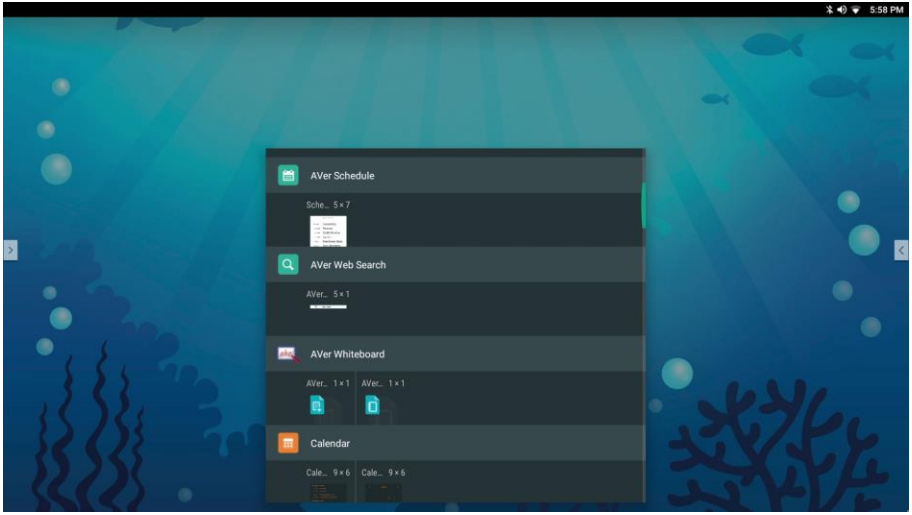

3. Click and hold the Schedule to edit.
4. Select **“Edit content”**.

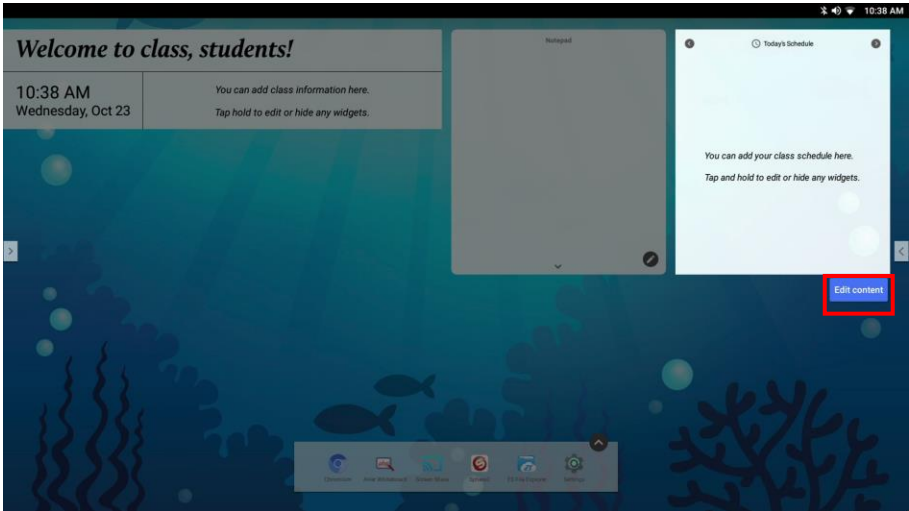

5. Select the day (Mon ~ Sun) and select **“Add item”**.

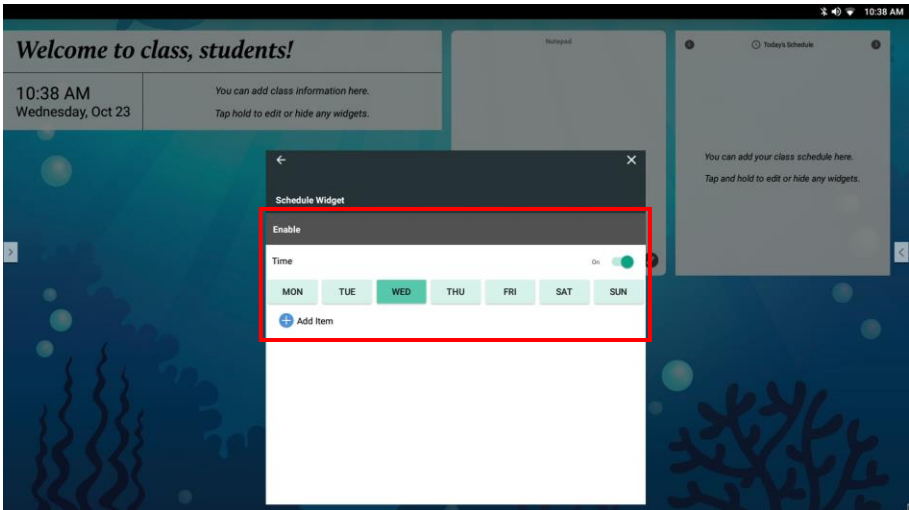

- Then, enter the name for the schedule (ex. Math). The maximum length of name is 15 characters.

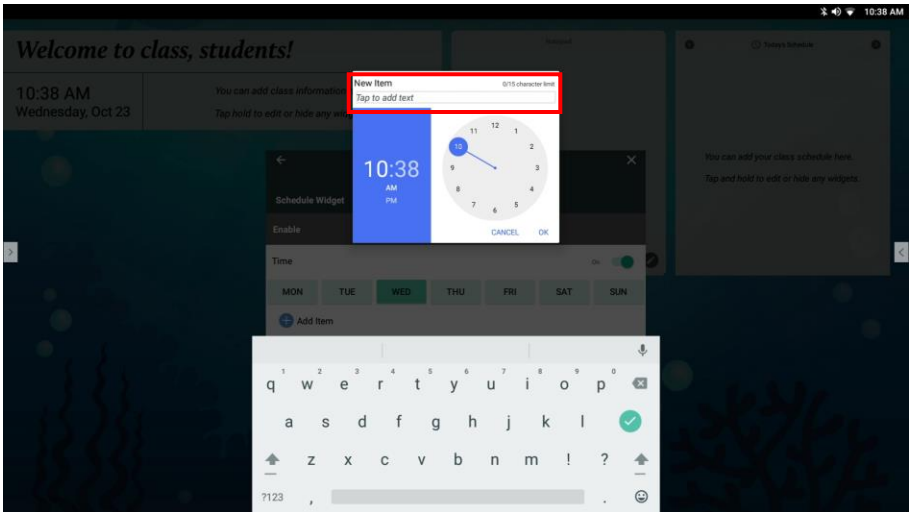

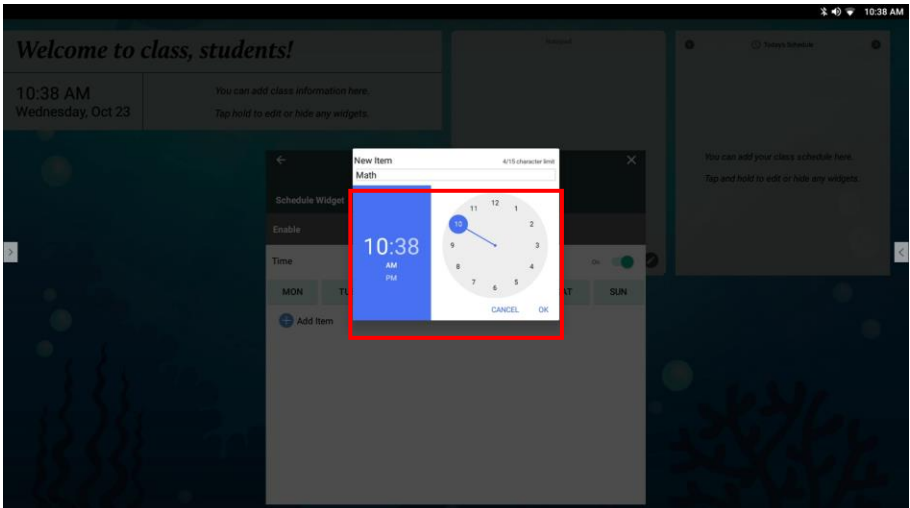

- Next, select the “Hour” and “AM/PM”.
- Then, select the “Minute” and click “OK” to save the settings.





9. A schedule will show in list.

10. User can add file and URL link for the schedule. Select “” to add file or URL link.

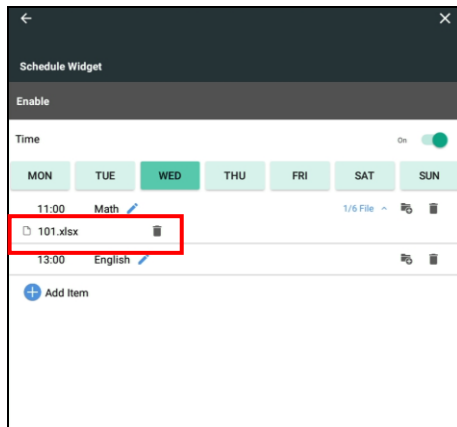
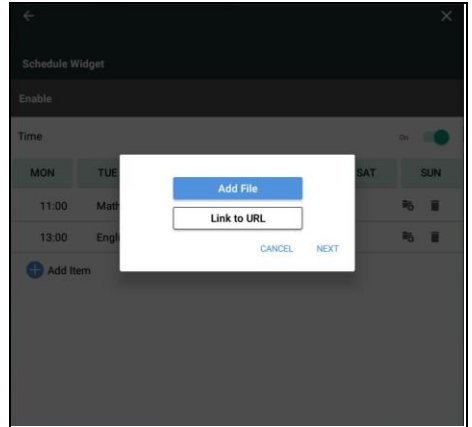
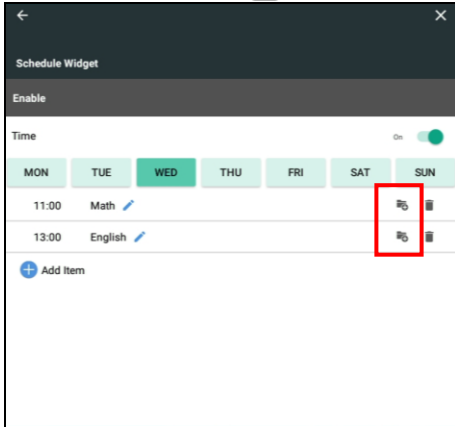
- **Add File:** Select “” > **Add File** and select the file. The added file will be listed under the schedule. Select “” can delete the file.



- Link to URL:** Select “” > **Link to URL** and enter the URL (ex: www.google.com) and the name of the URL. The added URL will be listed under the schedule. Select “” can delete the file.

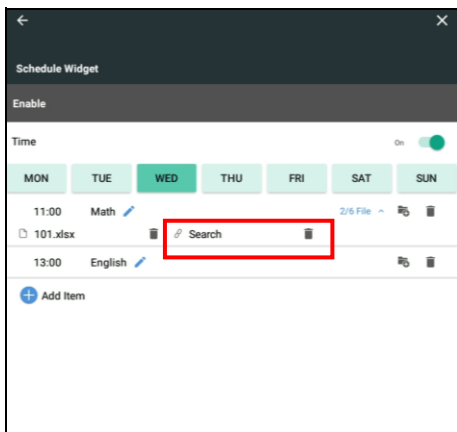
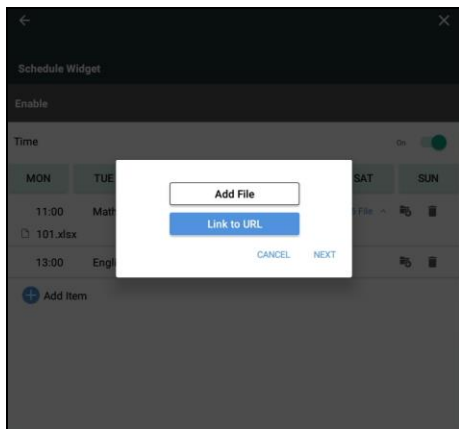
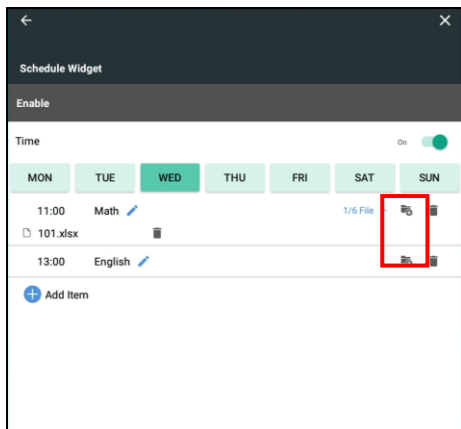

11. User can delete the schedule by clicking  icon.

12. To add more schedules, repeat above steps.



13. After setting schedule, click “←” to exit from Schedule page. Today’s schedule is displayed on the screen. Click “>” and “<” can view other schedule in other days. Click “>” can expand to view the attached file and URL.

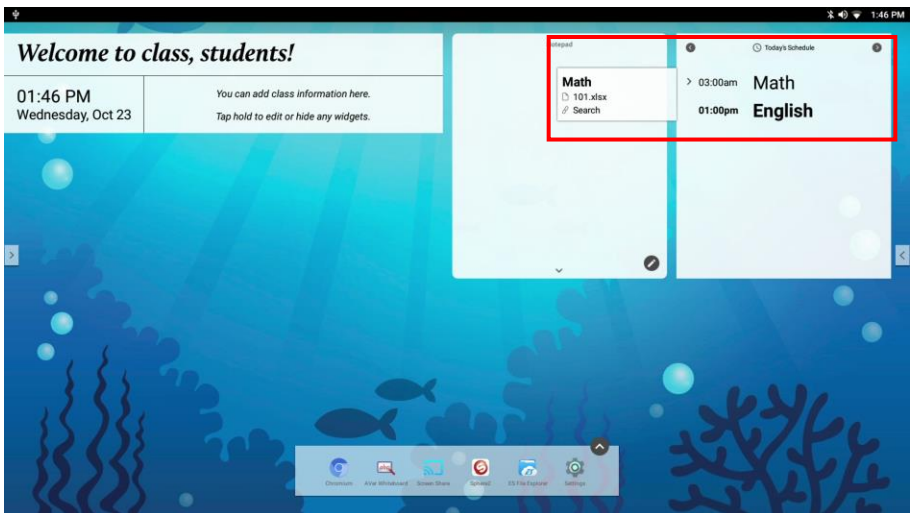

Disable the Schedule

Don't display the Schedule on the main screen.

1. Click and hold the Schedule until the “**Remove**” option is shown.
2. Move the Schedule to the “**Remove**” option. Then, the Schedule will be disappeared from the main screen.

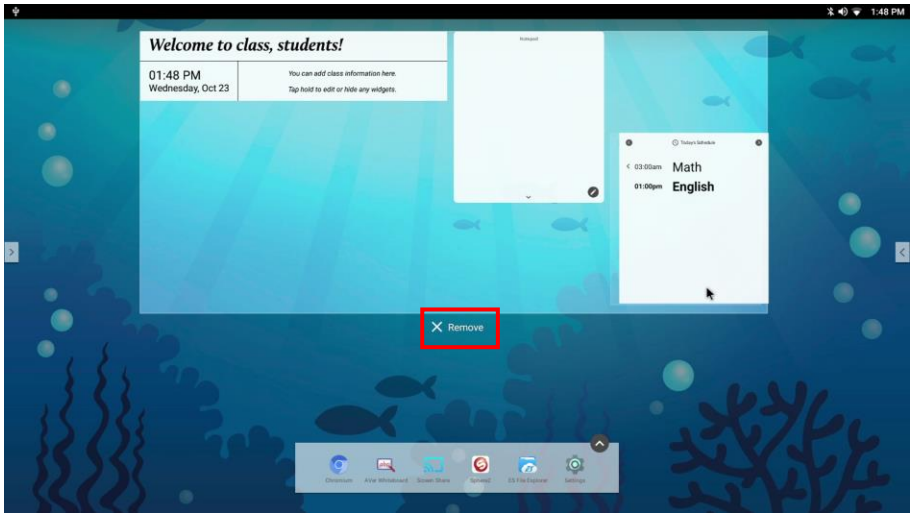

Pinned File

Put the favorite files and links for easily accessing.

Enable Pinned File

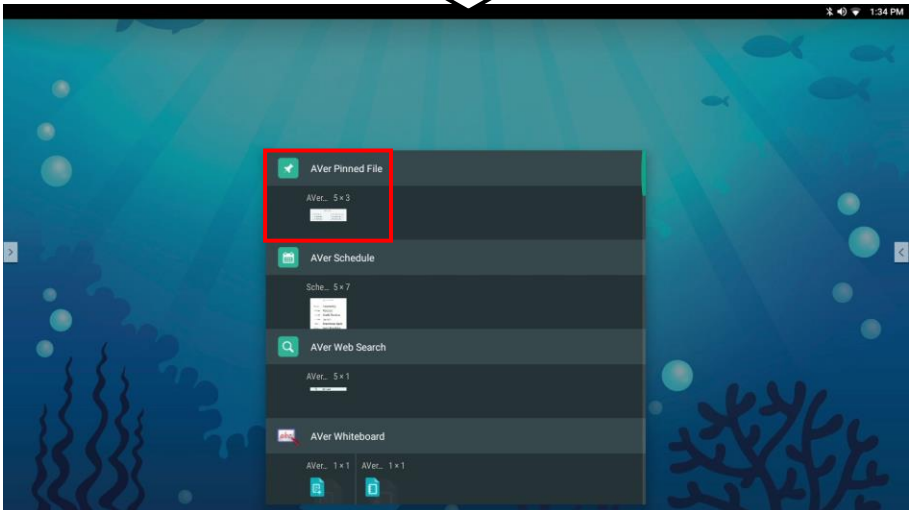
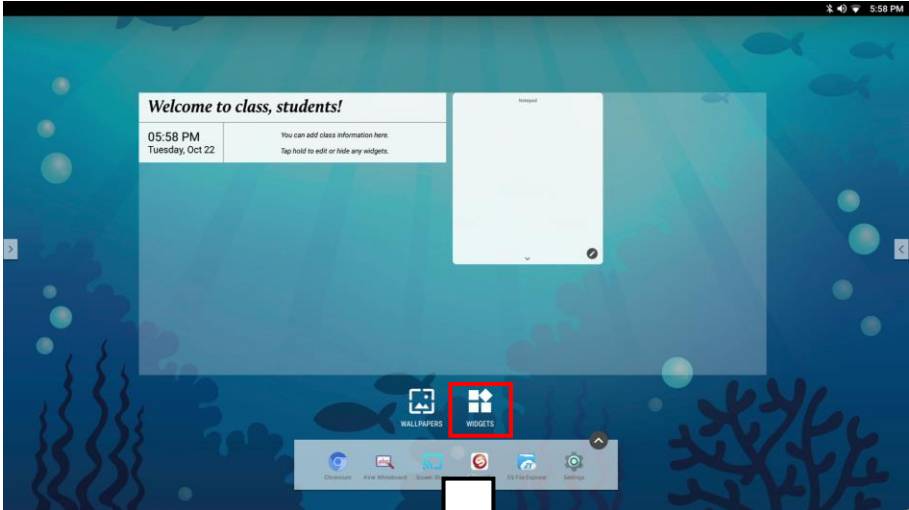

1. Click and hold the screen until the “**Widgets**” option is show n.
2. Select “**Widgets**” and select and drag the “**AVer Pinned File**” to the main screen.

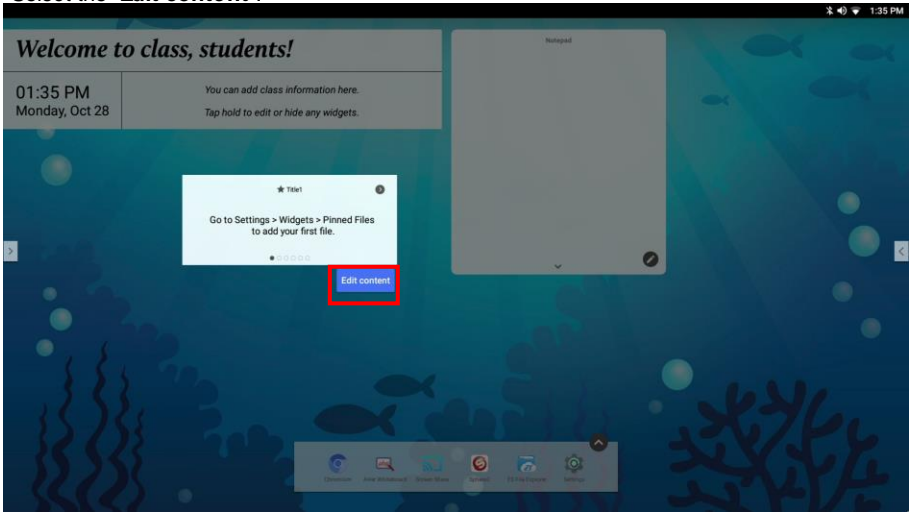

Edit the Pinned File

1. Click and hold the Pinned File to edit.
2. Select the “**Edit content**”.



3. Select “” can re-name the page of Pinned file. After enter the name, select “**Done**” to save. The maximum length is 18 characters. Total is 6 Pinned File pages, select  and  to switch it.

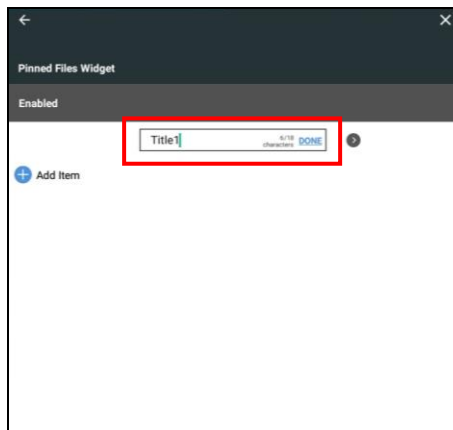

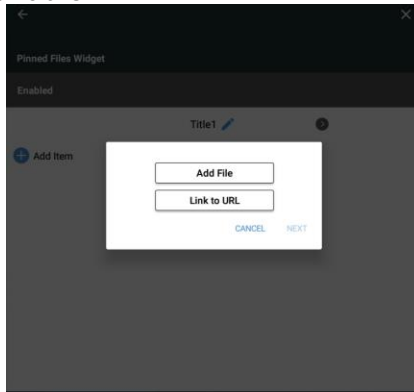

4. Select “Add Item” to add file or URL link.

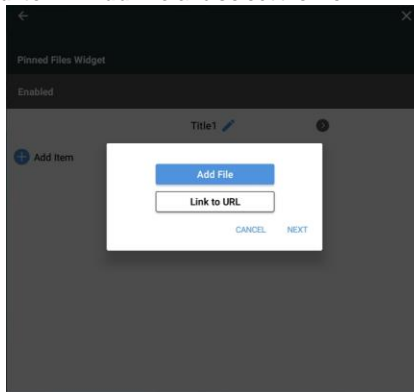

■ **Add File:** Select **Add Item > Add File** and select the file.



The added file will be listed on the Pinned File page. To delete, select “”. To change the order, tap and hold the “” to move.

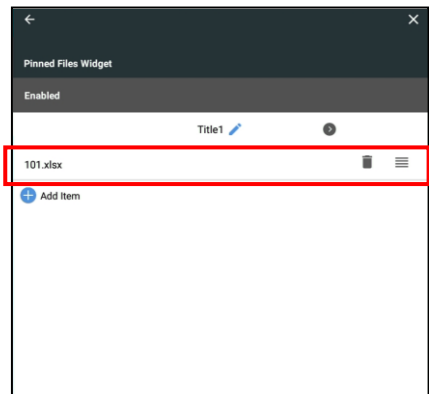

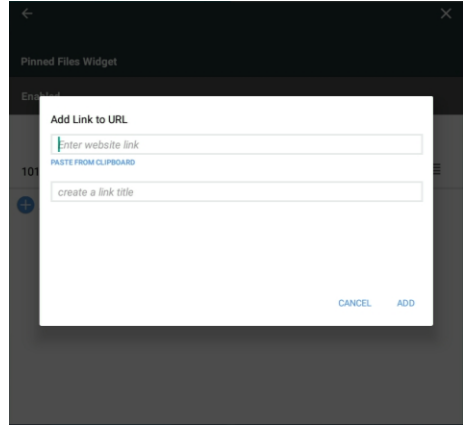
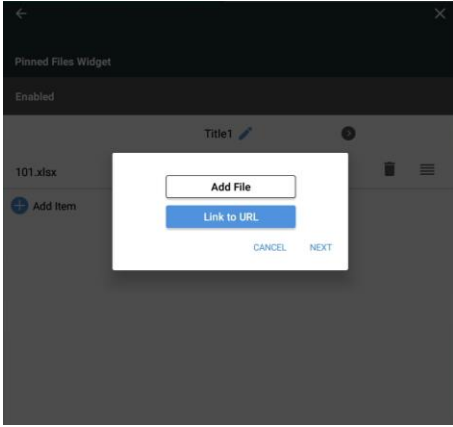

- **Link to URL:** Select **Add Item** > **Link to URL** and enter the URL (ex: www.google.com) and the name of the URL.

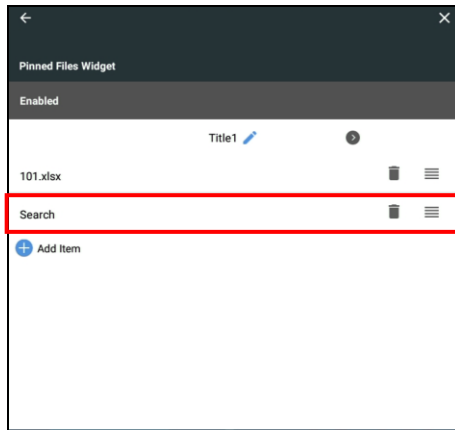

The added URL will be listed on the Pinned File page. Select “” can delete the file.



- After the setup finished, select “X” to exit the page. User should see the added file and URL link on the Pinned File page. Select file or URL link w ill open the file or the Web page. Select  and  can sw itch to different Pinned File page.

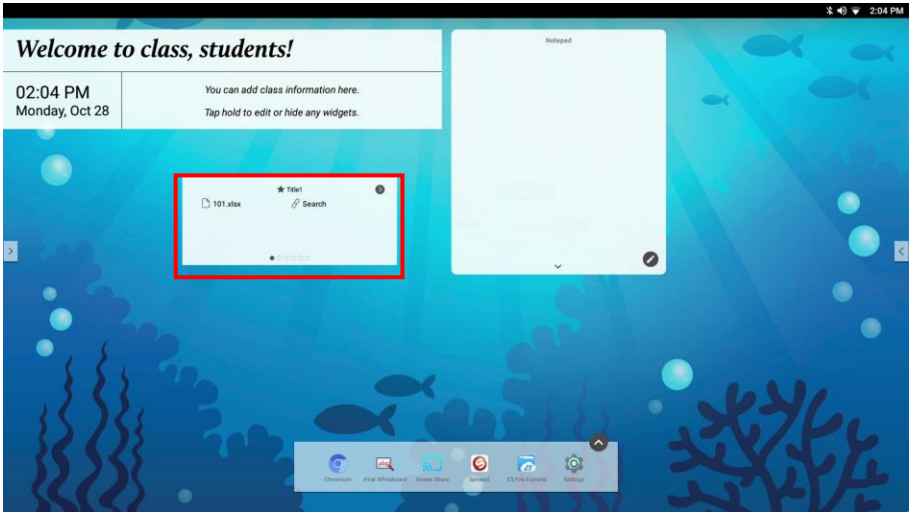

Disable the Pinned File

Don't display the Pinned File on the main screen.

- Click and hold on the Pinned File until the “**Remove**” option is show n.
- Move the Pinned File to the “**Remove**” option. Then, the Pinned File w ill be disappeared from the screen.

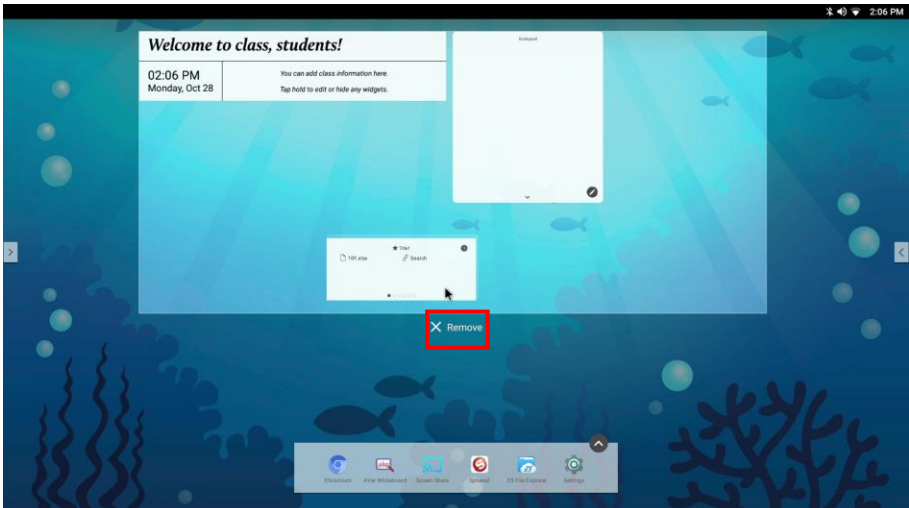

Web Search

Enter key word to search on the web.

Enable the Web Search

1. Click and hold the screen until the “**Widgets**” option is show n.
2. Select “**Widgets**” and select and drag the “**Aver Web Search**” to the main screen.

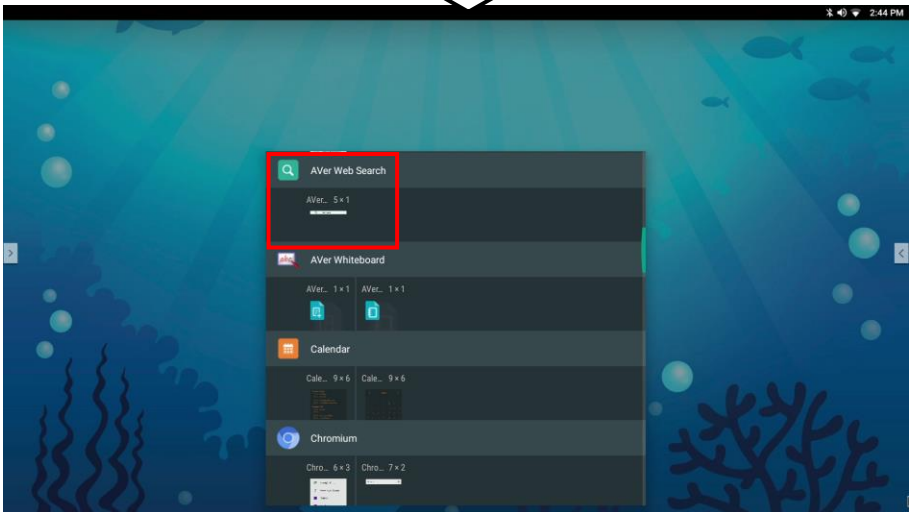
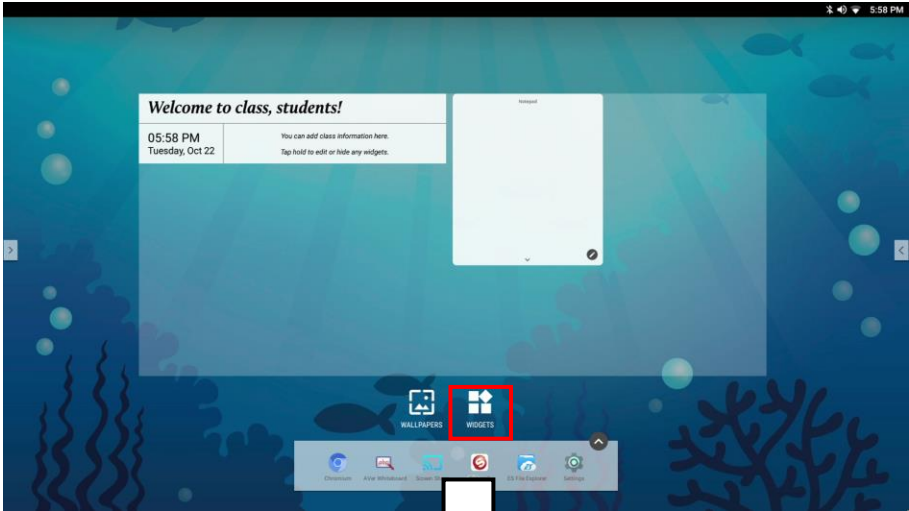

3. Enter the key word or URL to search.

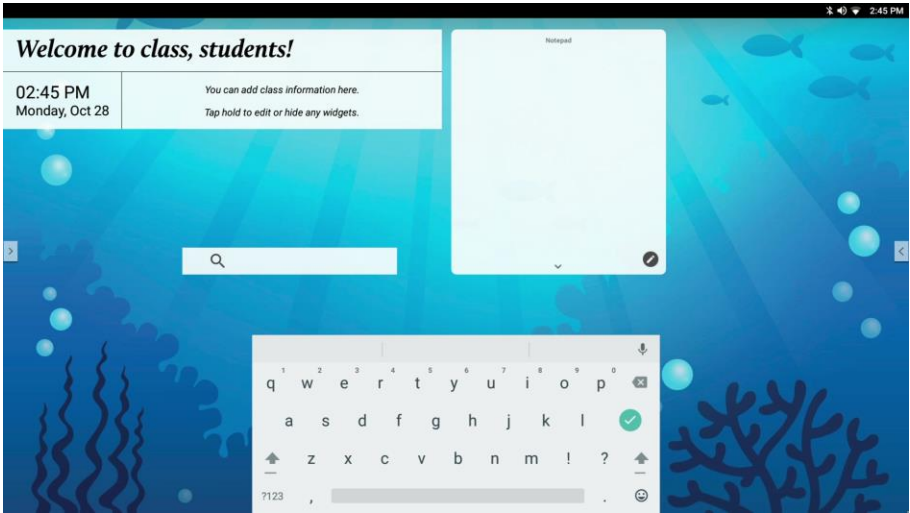



Disable the Web Search

Don't display the Web Search on the main screen.

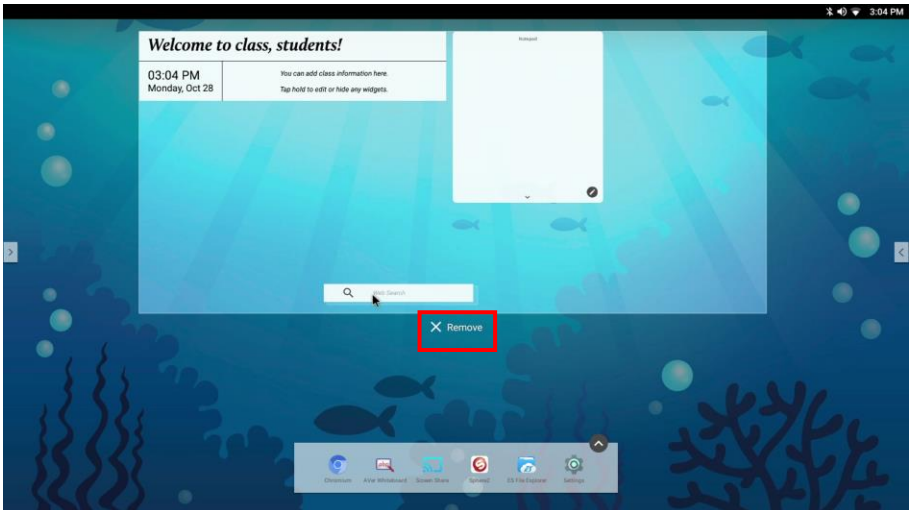
1. Click and hold on the Web Search until the "**Remove**" option is shown.
2. Move the Web Search to the "**Remove**" option. Then, the Web Search will be disappeared from the screen.



Tool Bar

The toolbar is located at both of the screen, tap  or  on the both side of screen to call out the toolbar. Click "X" to hide the toolbar.

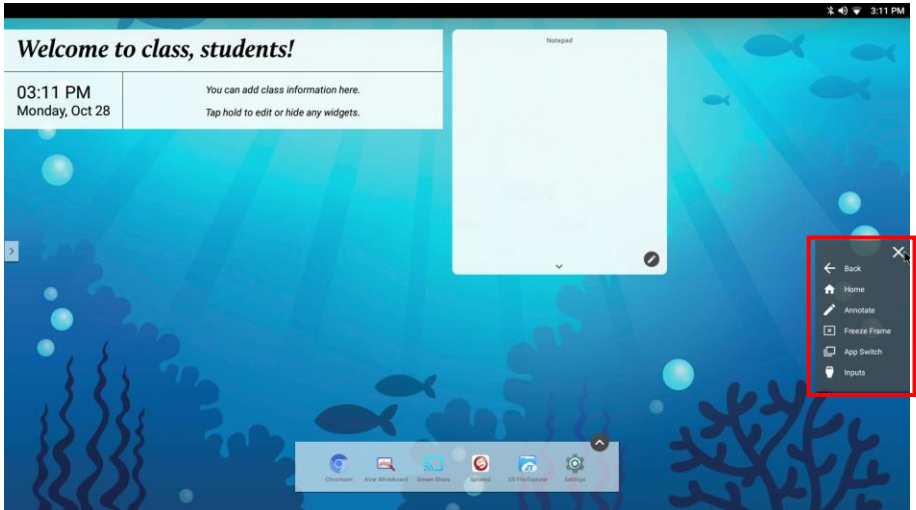

- **Back:** Back to previous screen.
- **Home:** Return to main screen.
- **Annotate:** Call out the annotation tool (Also see [Annotation Tool](#) section).
- **Freeze Frame:** In freeze status, user can operate the power menu and annotation function. To un-freeze, select "Un Freeze" from toolbar.
- **App Switch:** View recent running programs, switch to one of running program, and close the running programs. To close all running programs, click "**Clear All**".

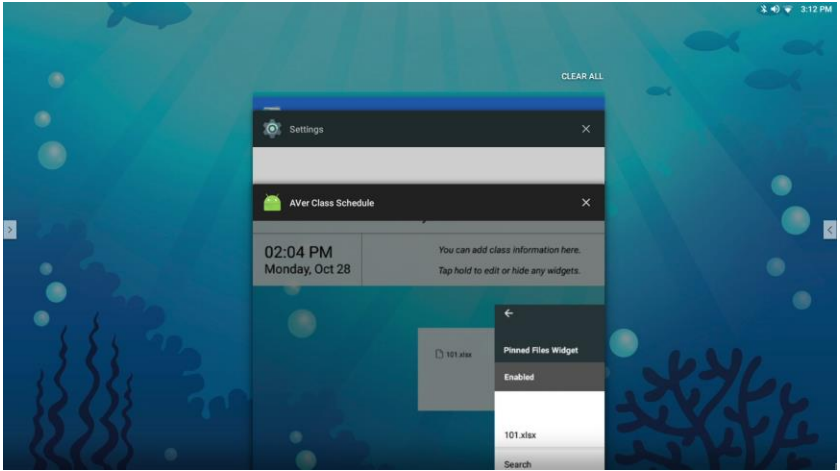

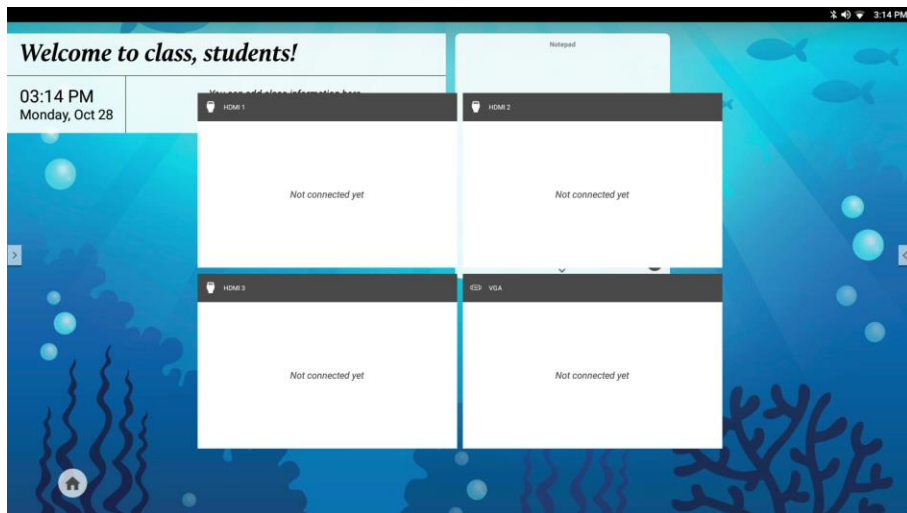

- **Inputs:** Select the input source which devices are connected with the AVer CB-310 system through HDMI, VGA, and Type C interface.

[Note] Press “” on the AVer CB-310 can call out the input source selection.



Annotation Tool

The annotation tool can be used in any input source screen.

Select  or  on the main screen, then, select  to call out annotation tool.

 (Eraser): Clear the annotation on the screen.

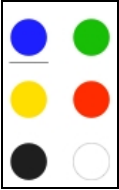

(Pen color): User can select the color and draw /write on the screen.

 (Save): Save the screen to local disk or external USB pen drive.

 (Exit): Close the annotation tool.

 (Clear): Clear all annotations on the screen.

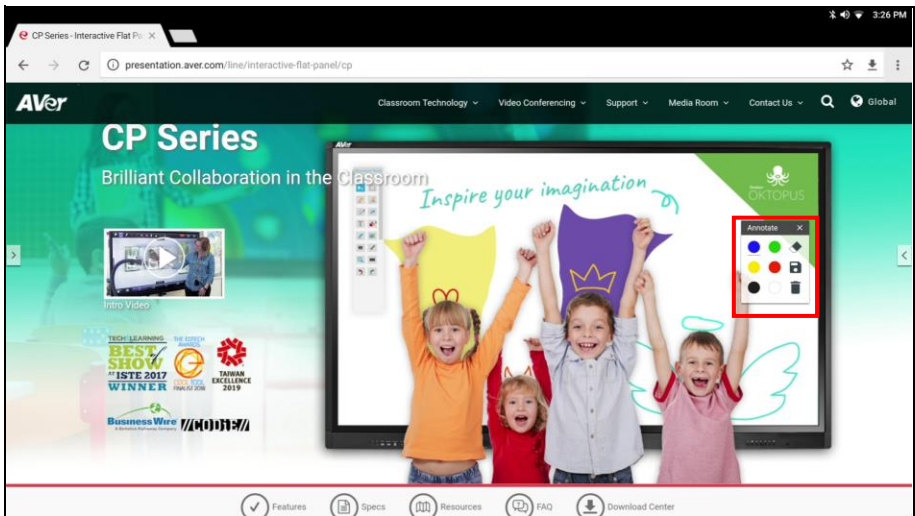

Split-Screen Mode

The AVer CB-310 system supports 2 split screens display.

1. Select “**App Switch**” from Tool bar.
2. Click the one app and hold, then, move to the side of screen (left or right) to switch to split-screen mode. Also, user can select input source to display in split-screen mode, too.

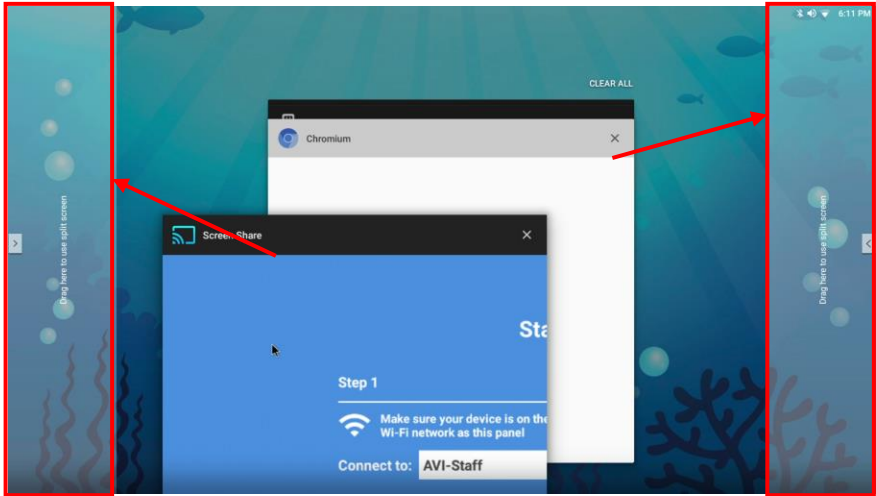

3. In split-screen mode, left screen is fixed display, right screen is replaceable that user can switch another app/input source to display on the screen.

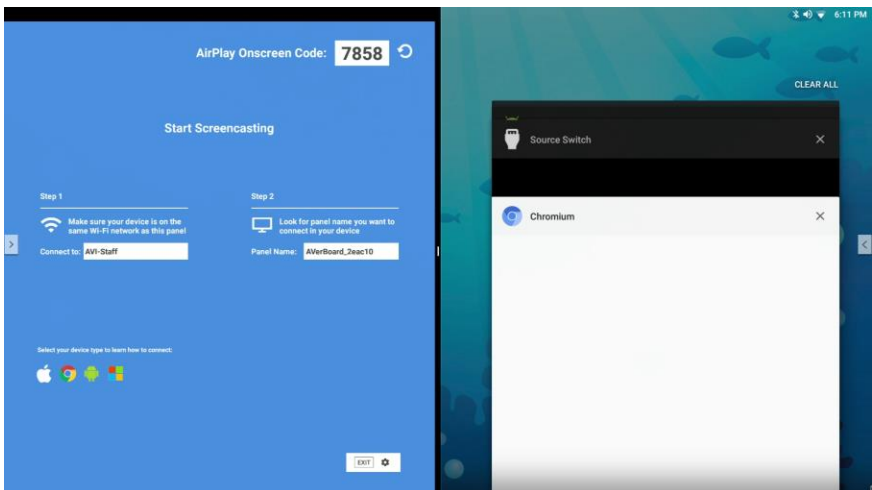

4. The split screen can adjust size by click the edge of split screen and move to left of right side.

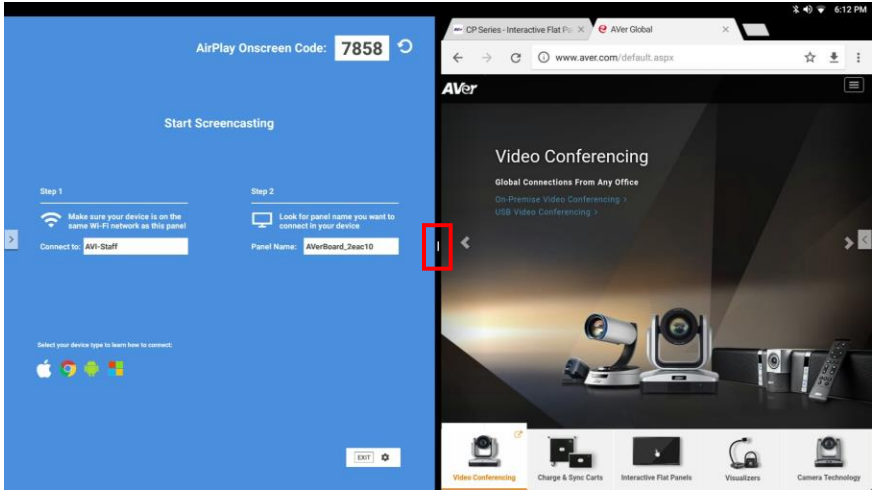

5. To return to normal screen display, click the edge of split screen and move the way down to left or right side.

Multiple User

AVer CB-310 supports user login mechanism to allow different users to log in and have their own environment settings and save.

Enable Multi User

Before to login with user account, please enable the multi user function.

1. Select the “**Settings**” icon to bring out the Settings page.
2. Select “Multi Users” and enable multi user function.

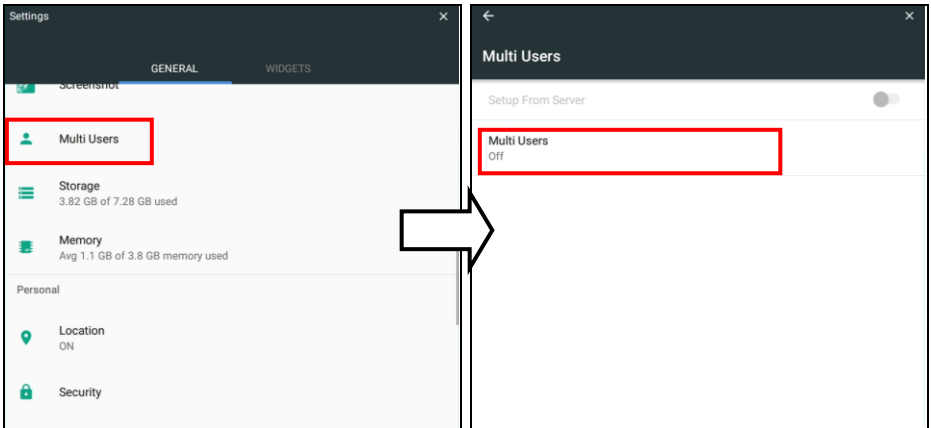

3. The system will require user to set the password for security. Select “**SET PASSWORD**”.

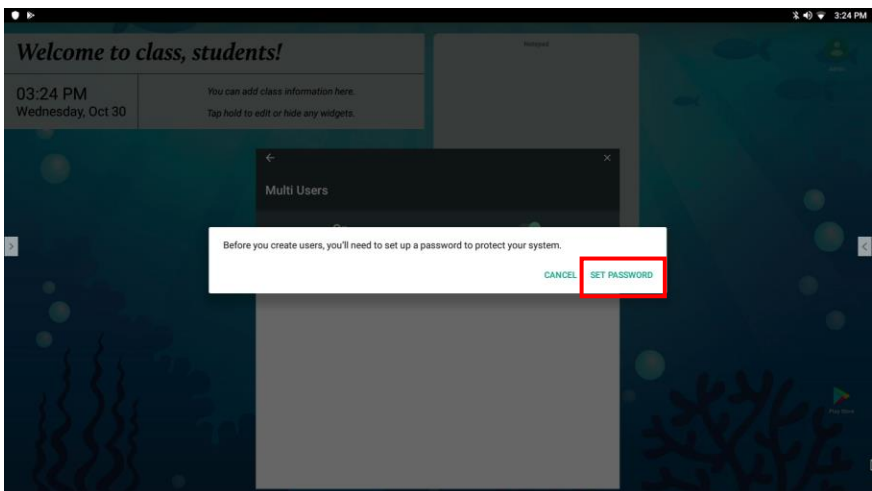

4. Enter the password (at least 4 characters) and re-enter the password to confirm.

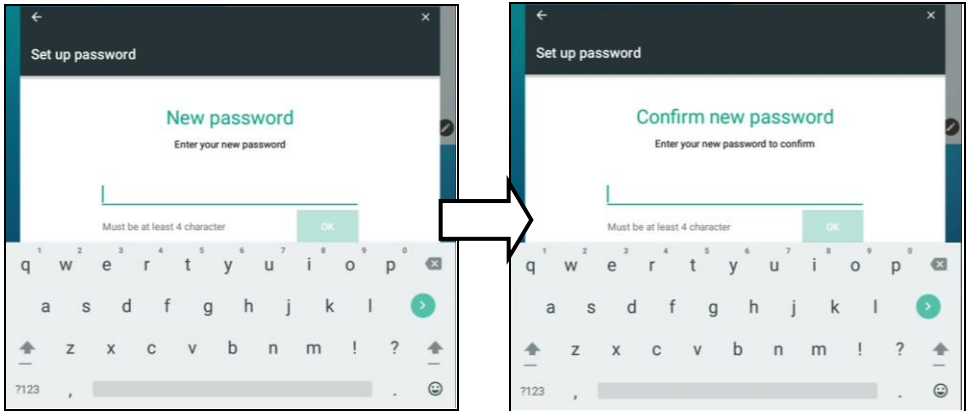

5. After completing password setup, the multi user function is enabled.

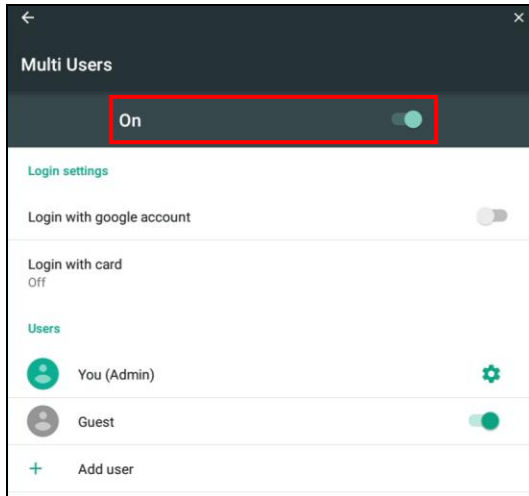

Add User Account

The Admin account has authority to add new user account.

1. Select “” > **Multi User > Add User**.

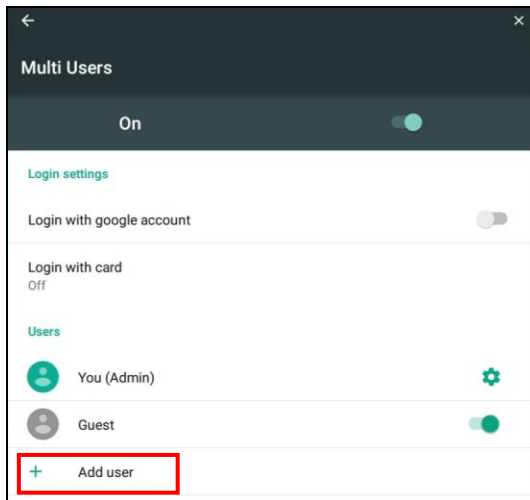

2. Enter the user name for the account, ex: Amy. Then, select “NEXT” to set the password.

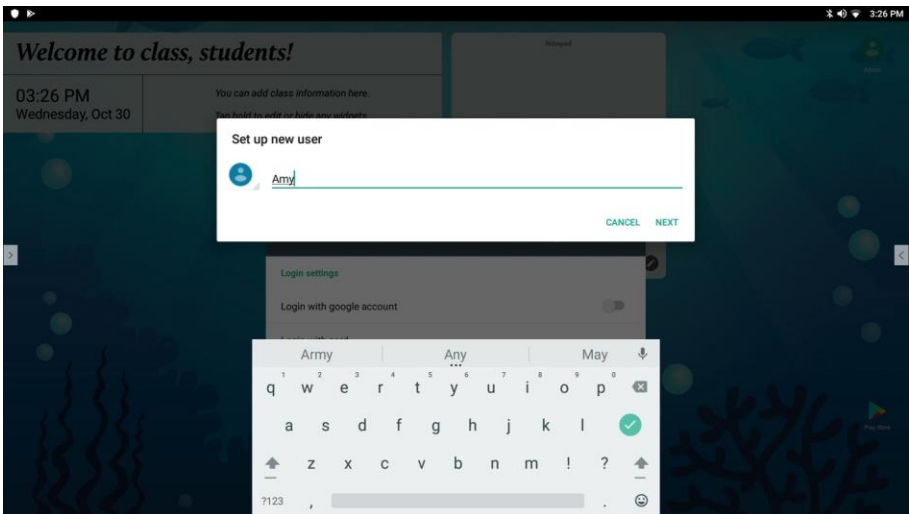

3. Enter the password for the user account (4 characters at least). Then, click “**Next**” to complete the setup.

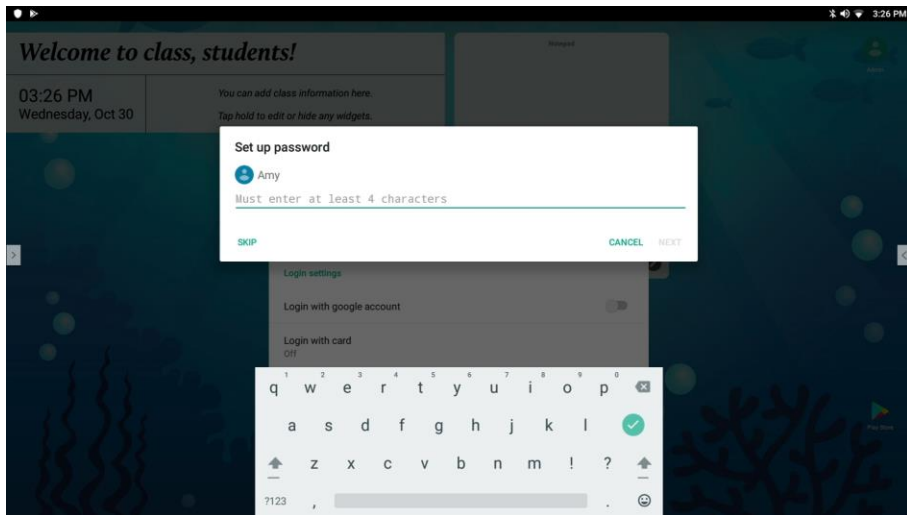

Login with the User Account

1. Press power button on the AVer CB-310 unit. Select “LOGOUT”. The logout option will show only when “Multi user” function has enabled.

[Note] The user needs to logout from current account in order to login within your own account.

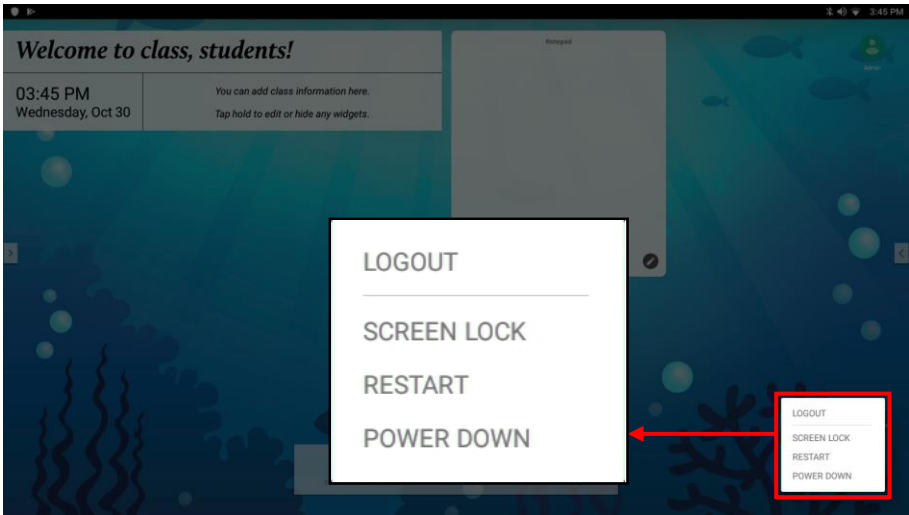

2. All user accounts will list on the screen.

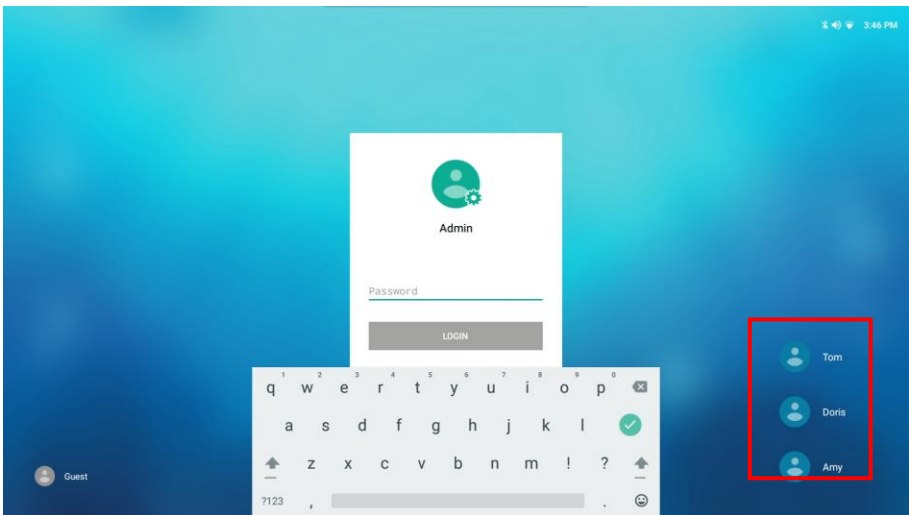

3. Select the user account that wants to login within. Enter the password of the user account and select "LOGIN".

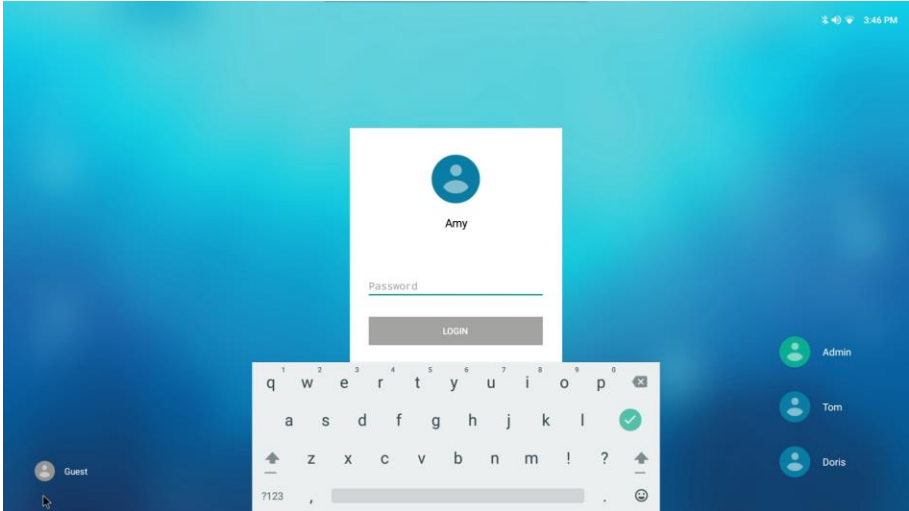

4. For the first time login, follow the on-screen instruction to complete the start-up.
5. After login, the user should see your account name is displayed on upper right corner of the screen.

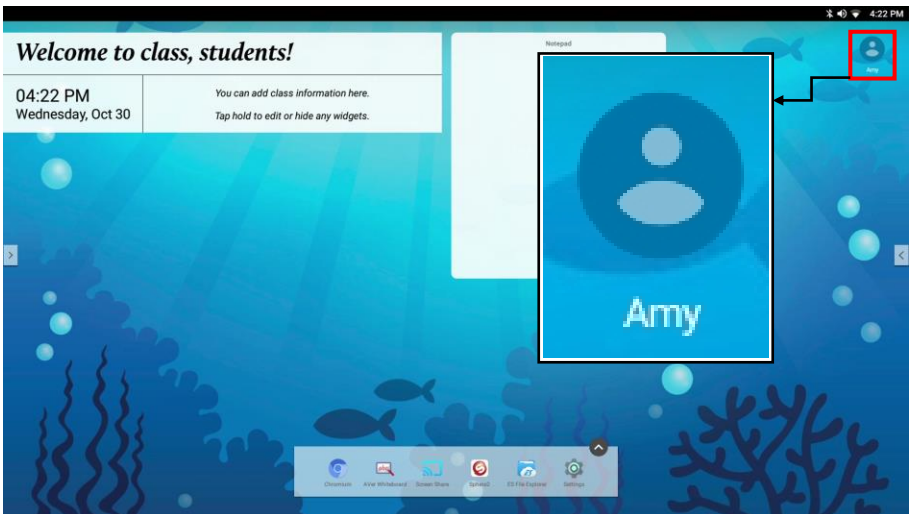

6. To login within another user account, repeat the step 1 to step 5.
7. If login with "Guest" account, all the data (ex: pictures, login information, file..etc.) will not save on the system after logout.

Change the Password

User can change the password of the account.

1. After login, select  > **Multi User** >  of your account (ex: You(Amy)).

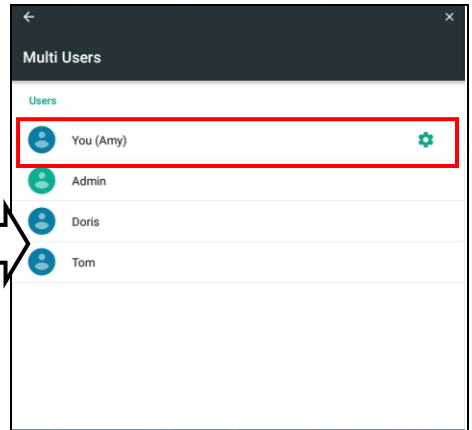
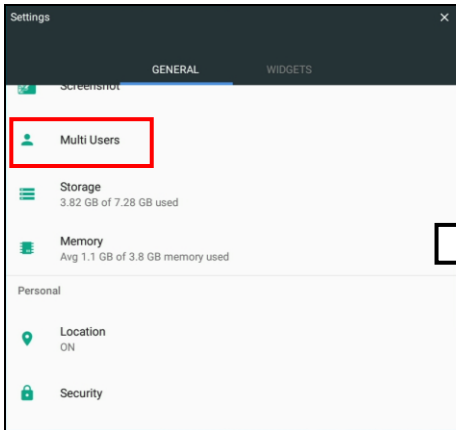

2. Select **Password**. Enter the current password.

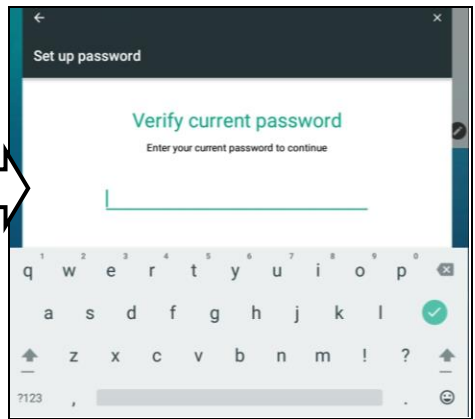
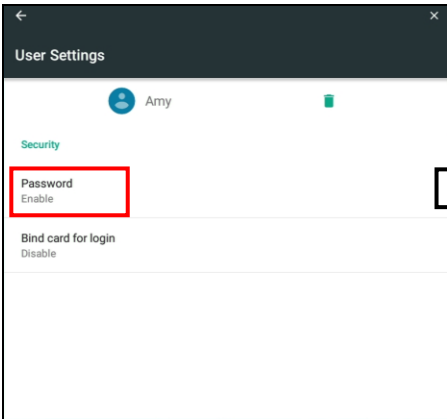

3. Select **Enable** to change the password.

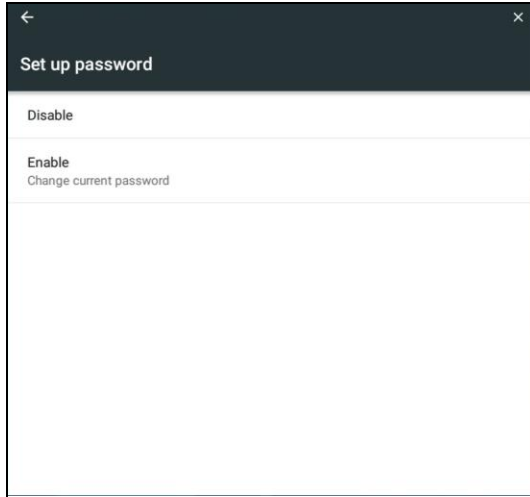

4. Enter the new password and re-enter the password to confirm.

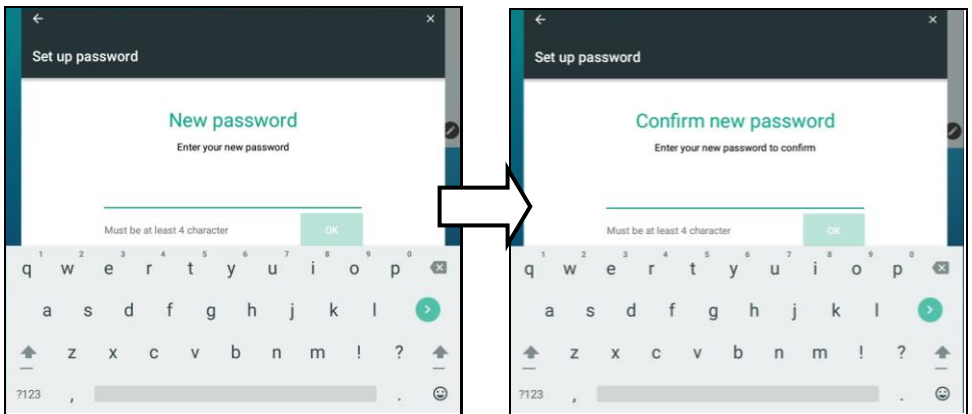

Delete the User Account

The user can delete your own account. Once the user account is deleted; the system will logout and back to the login screen.

1. After login, select  > **Multi User** >  of your account (ex: You(Amy)).

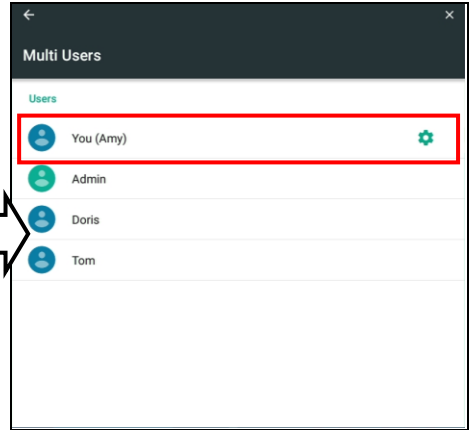
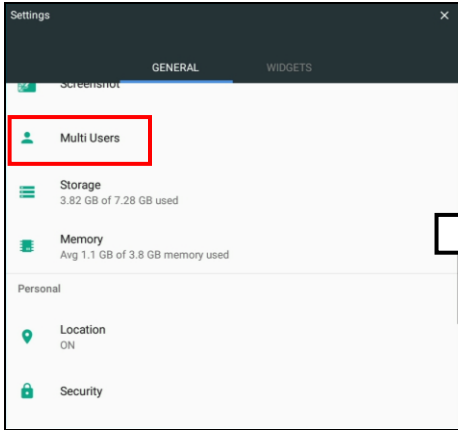

2. Select  > **DELETE**

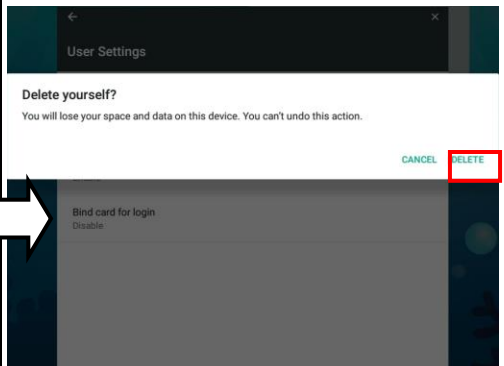
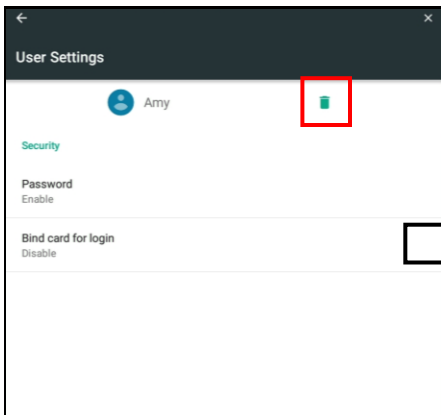

3. The system will return to the login screen.

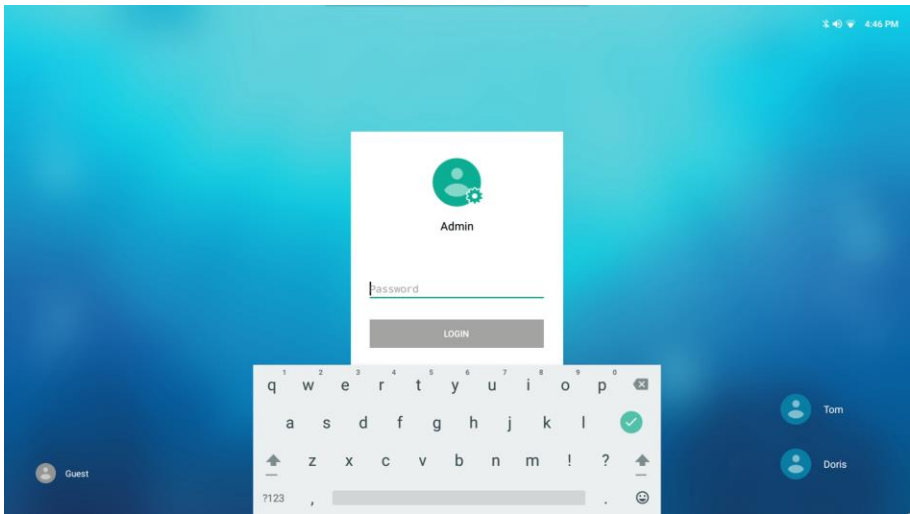

Admin Account Management

Change the Password

The AVer CB-310 system has two default user accounts – **Admin** and **Guest**. The Admin account can be modified; the Guest account is not modifiable.

1. Select  of You (Admin) account to change password and enable/disable password.
2. Select “**Password**”.

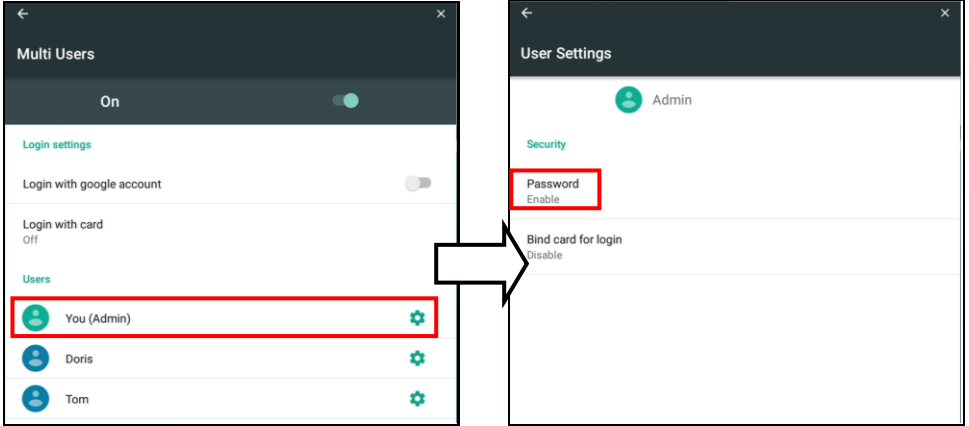

3. Enter the current password.

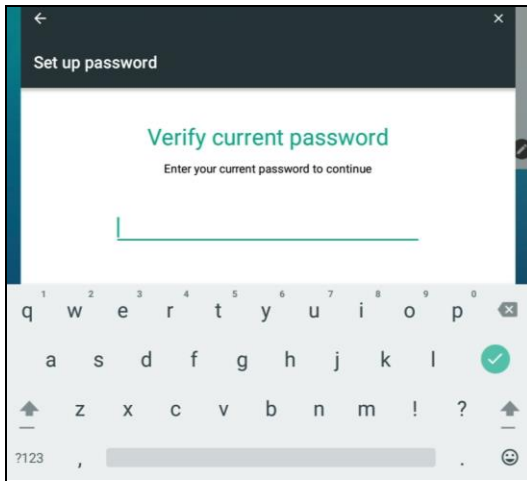

4. Select “**Enable**” to change the password.

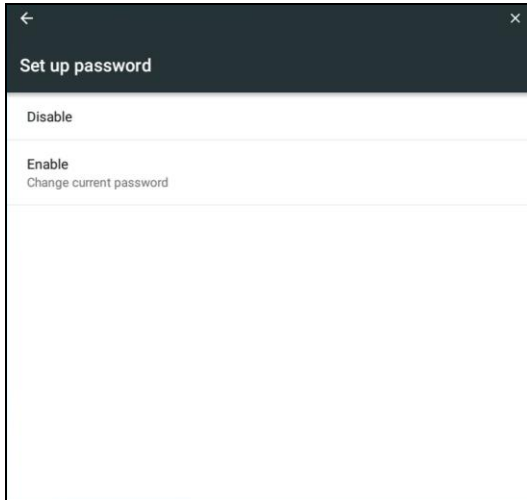

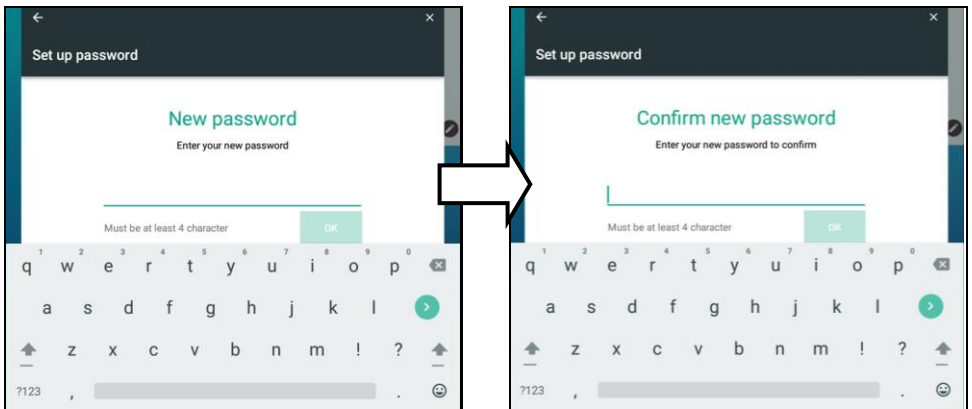

5. Enter the new password and re-enter the password to confirm.



6. If user selects “**Disable**”, then, the multi user function is disabled.

Change Account Profile

The Admin and user account name and photo can be changed.

1. Select “” > **Multi User** >  of your account(ex: You(Admin) or You(Tom)).

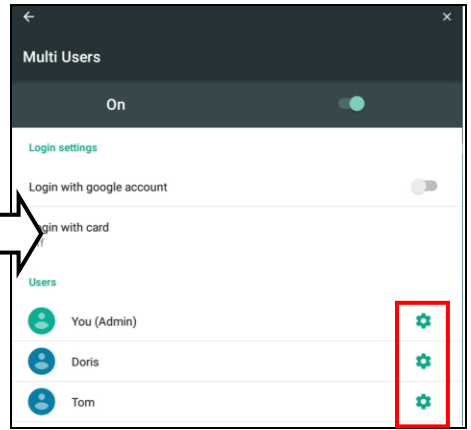
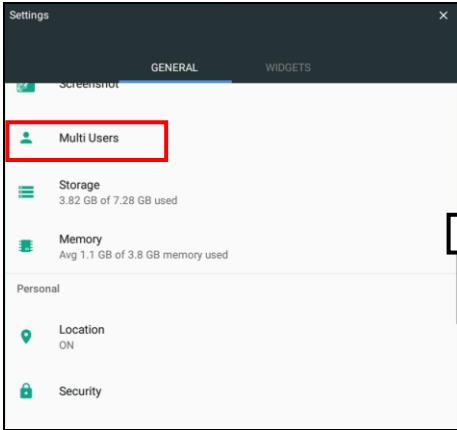

2. In account setting page, select account name and change profile dialog will show up.
3. To change the account name, enter the new name in column.

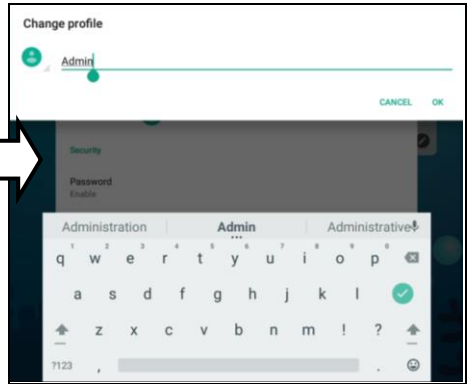
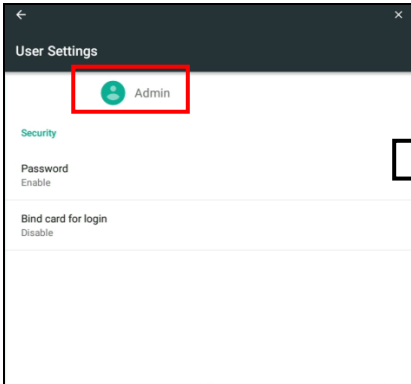

4. To change the account photo, click photo and select **“Choose photo from Gallery”**.

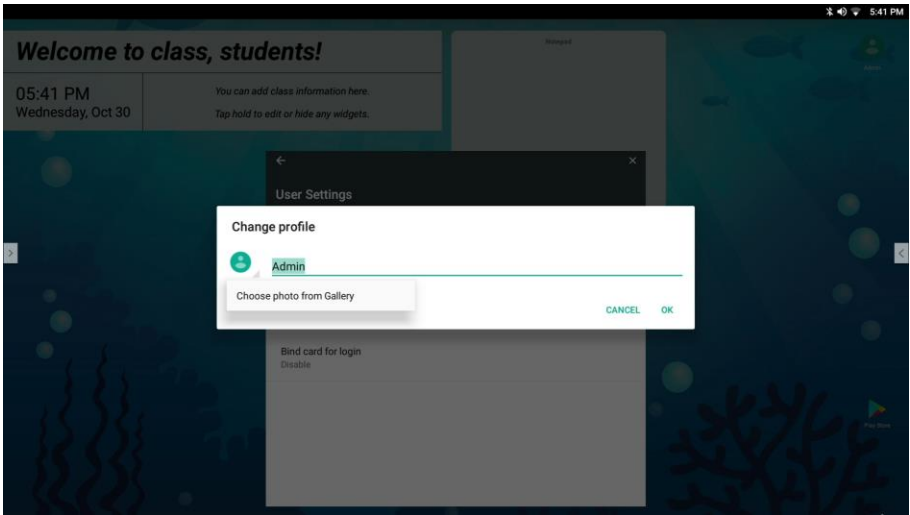

5. In Gallery page, select the photo and adjust the area of photo as you're wanted. Then, click **“Save”** to change the photo.

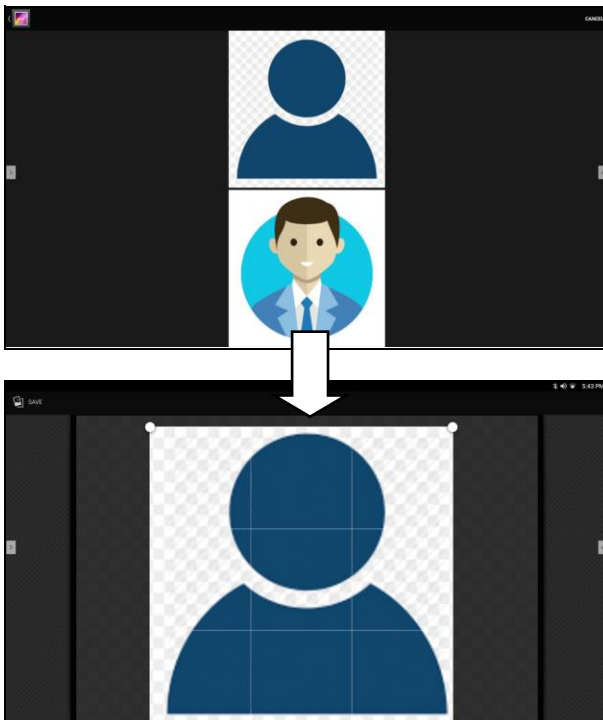

6. After changing the photo, click “OK” to complete the changing.

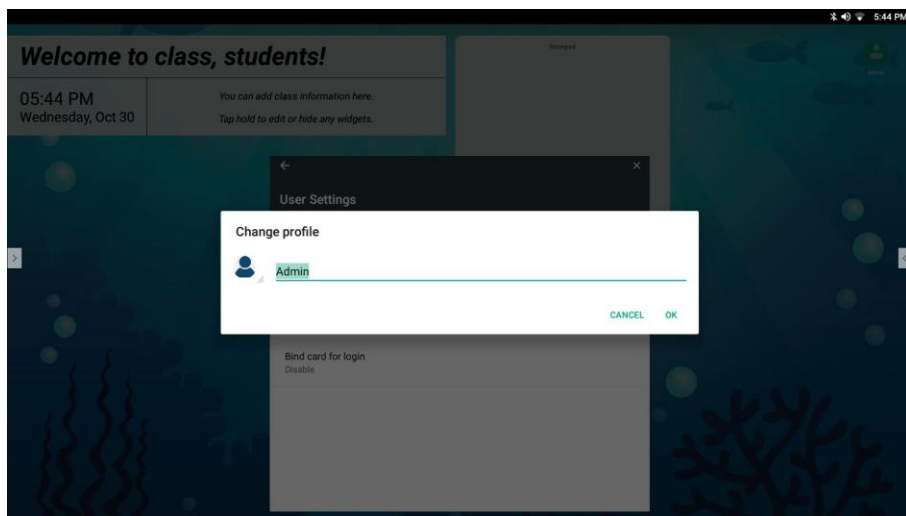

Setup User Account Access Authority

The Admin can set the permissions of the user account on the system.

1. Select “” > **Multi User** >  of user account (ex: You(Tom)).

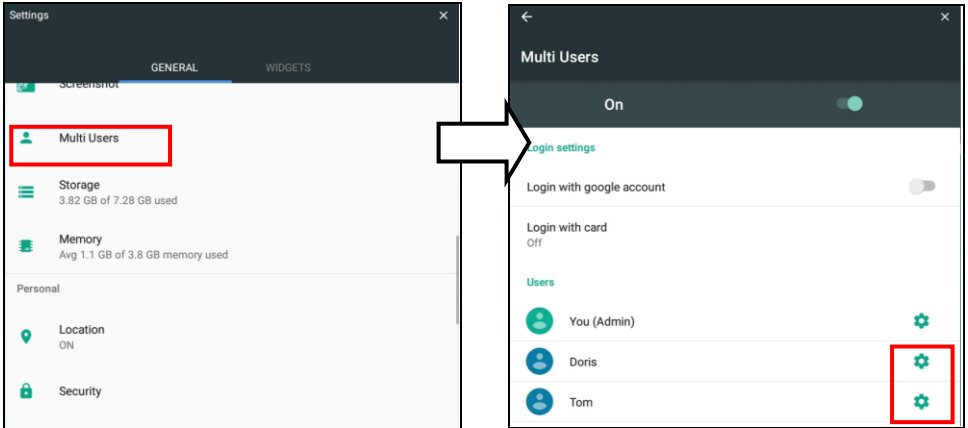

2. In App and content access, click  of the apps or contents (that allow user account to access or deny to access).

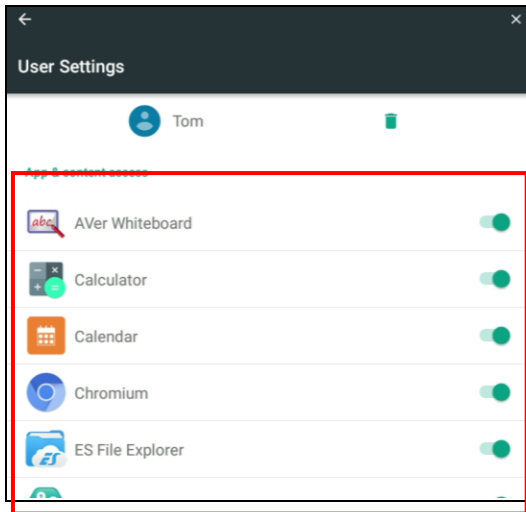

Login with Google Account

The AVer CB-310 system allows a user to use a Google account to login.

1. Select  > Multi User and enable “Login with google account”.

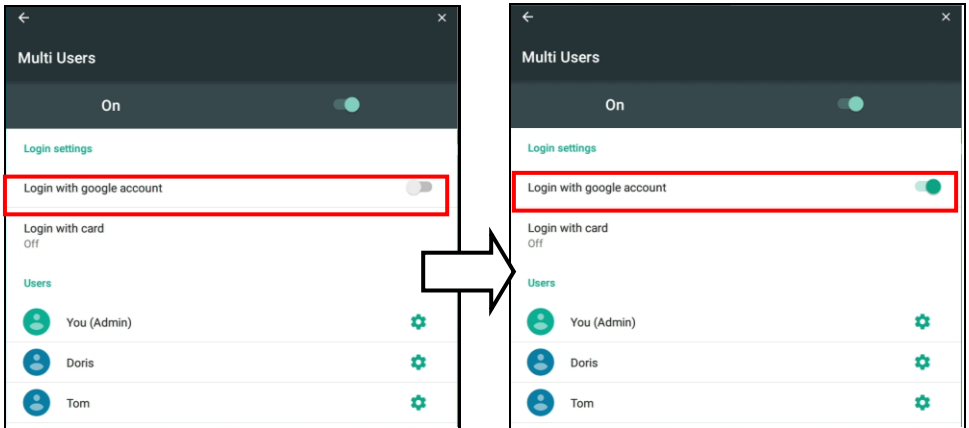

2. Press power button of the AVer CB-310 unit and select “LOGOUT”.
3. Select “Add user with google account”.

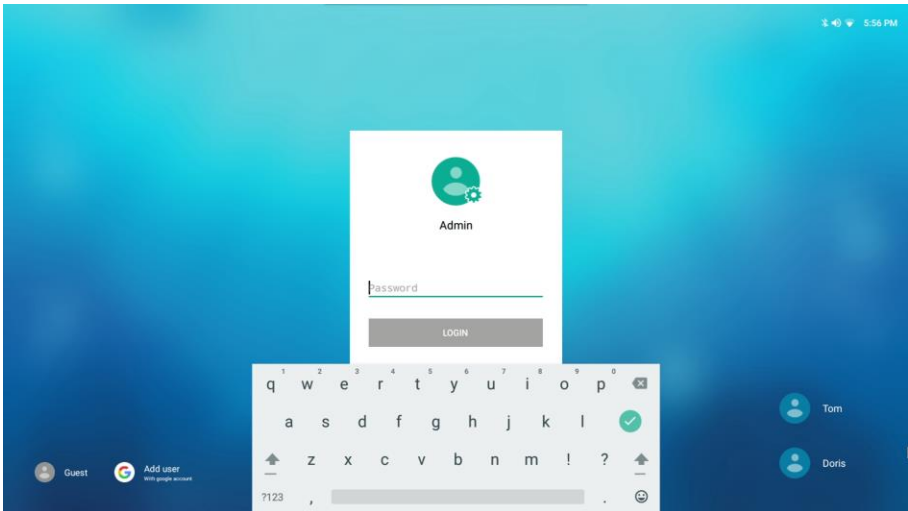

4. Then, enter your google account and select “Next”

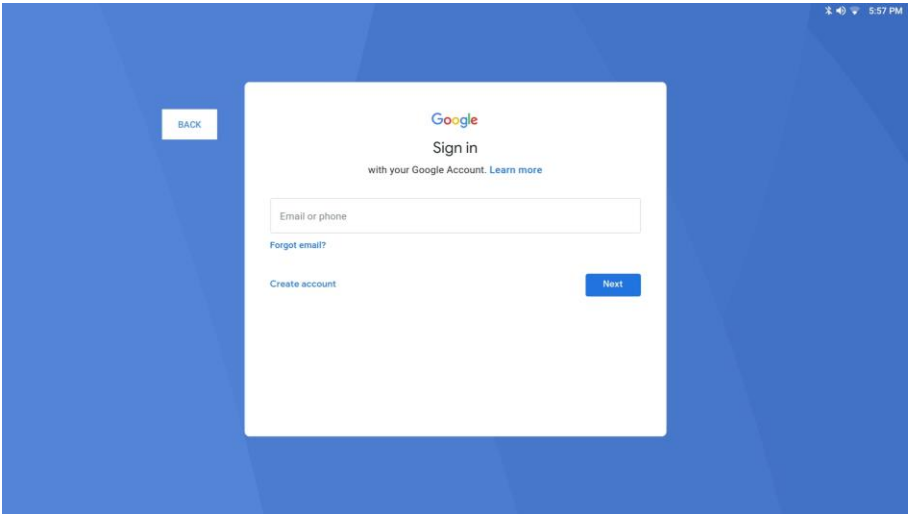

5. Enter your google account password and select “Next”.

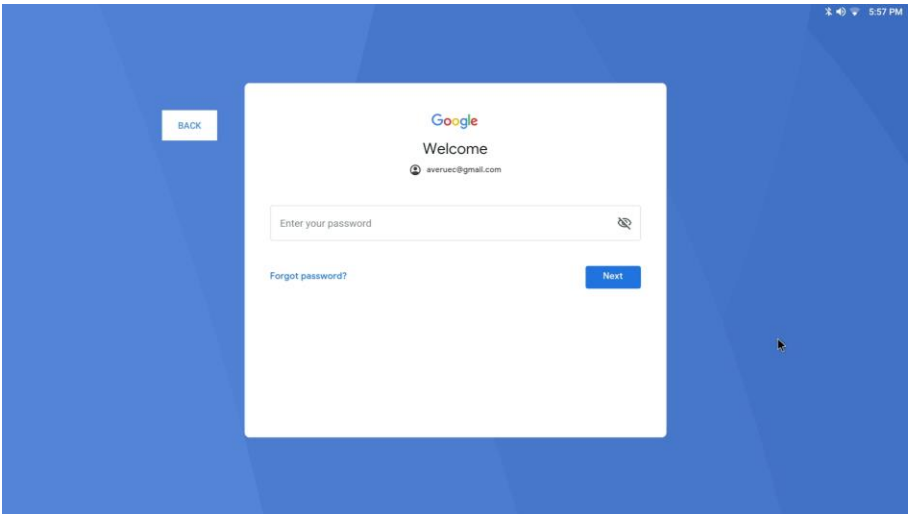

6. Then, select “Agree” to accept the term of service and privacy policy.
7. The user can choose to view the tour or skip tour.

8. After view the tour, the user can start to use the AVer CB-310 system. The user should see your account is displayed on the upper right corner and the google account has created on the system.

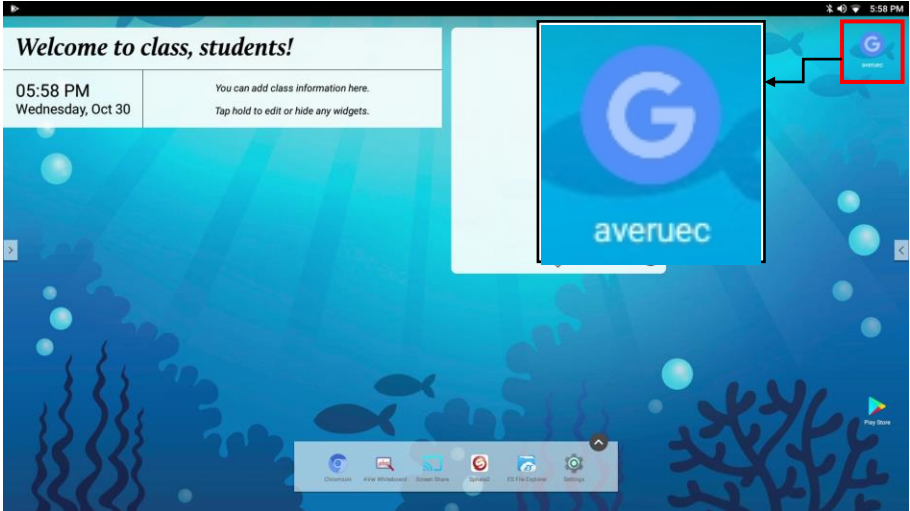

9. User will see the google account lists on the login screen next time.

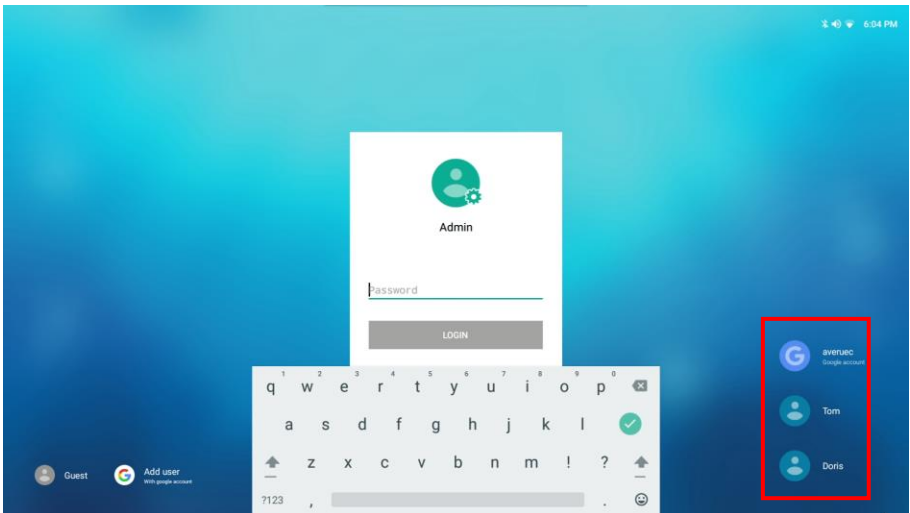

Change Google Account Profile

The Google account name and photo can be changed at AVer CB-310 system, but will not change your Google account.

1. Select  > **Multi User** >  of your google account.

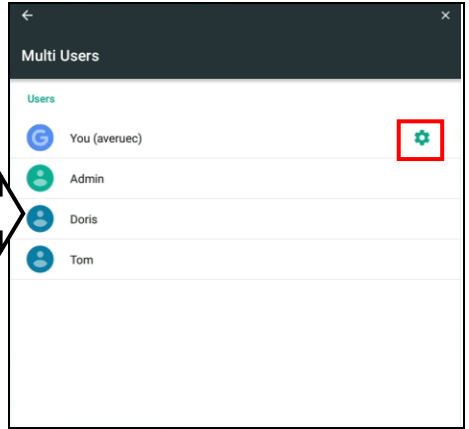
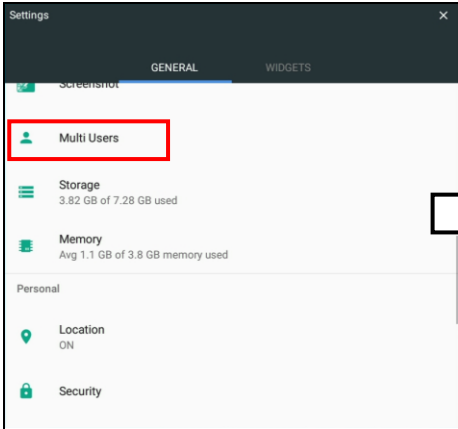

2. In account setting page, select account name and Change profile dialog will show up.
3. To change the account name, enter the new name in column.

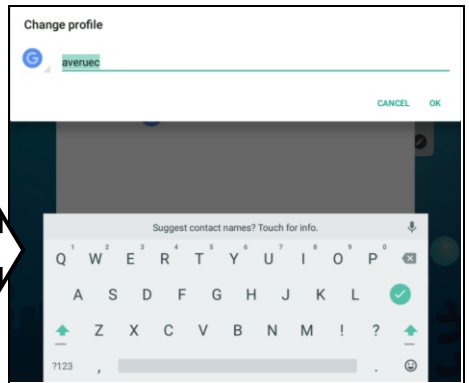
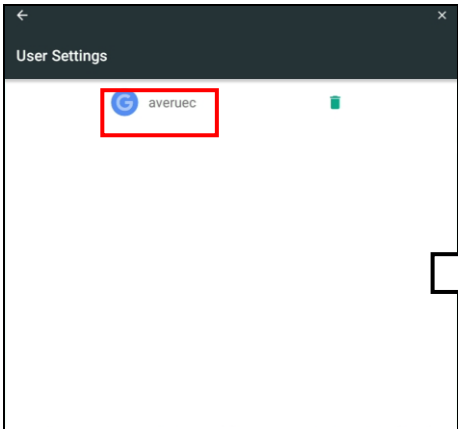

4. To change the account photo, click photo and select “**Choose photo from Gallery**”.

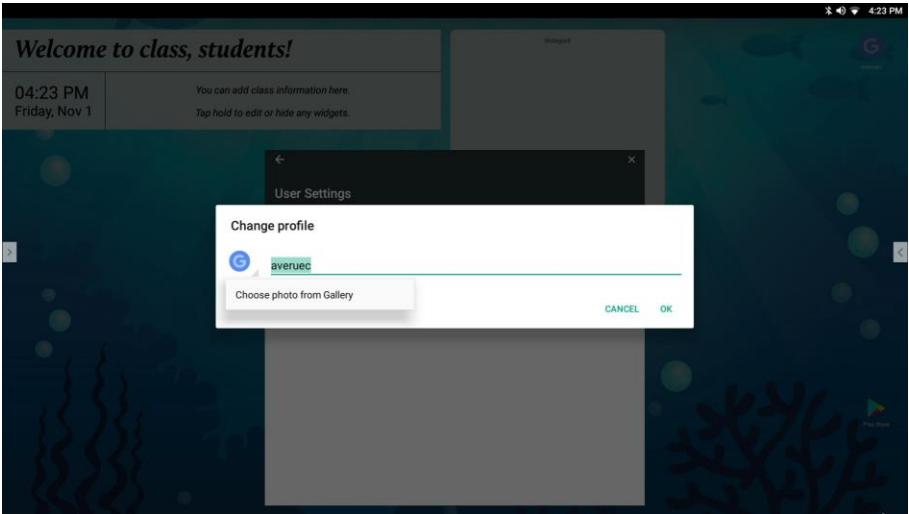

5. In Gallery page, select the photo and adjust the area of photo as you're wanted. Then, select “**Save**” to change the photo.

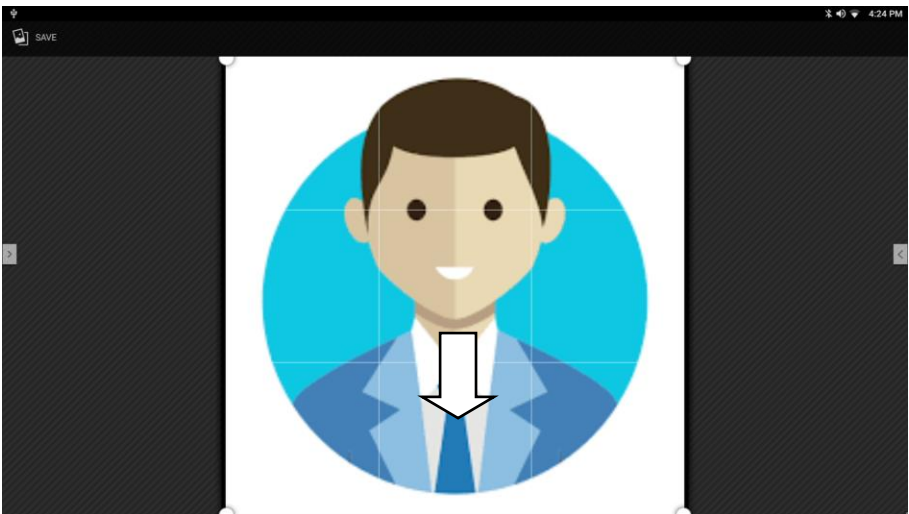

6. After changing the photo, tap “OK” to complete the changing.

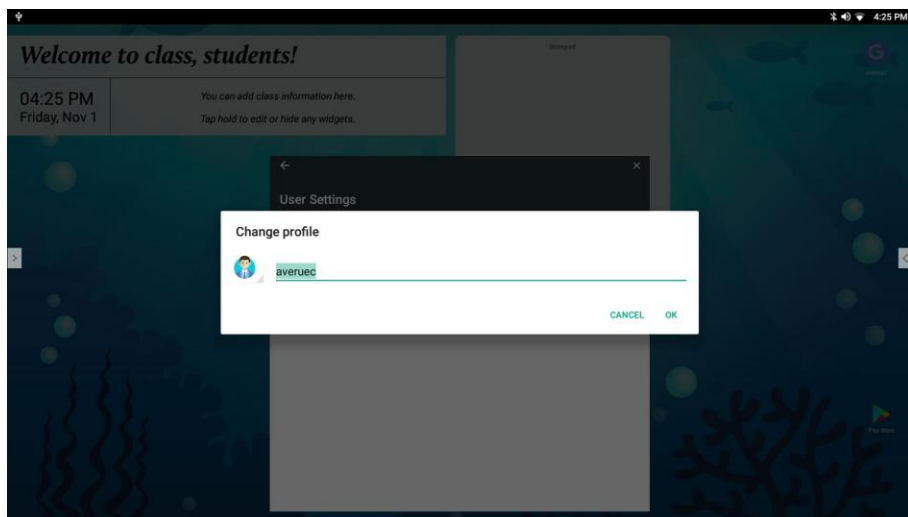

Delete the Google User Account

The user can delete your google account. Once the google account is deleted; the system will logout and back to the login screen.

1. After login, tap  > **Multi User** >  of your account(ex: You(averuec)).

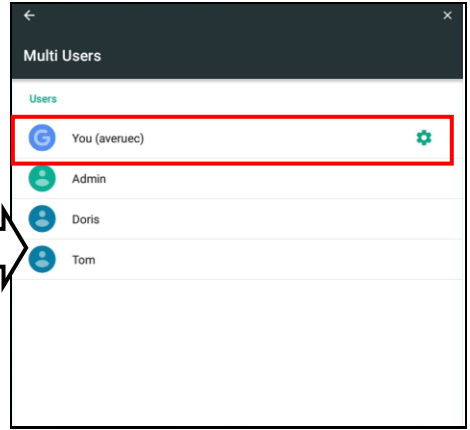
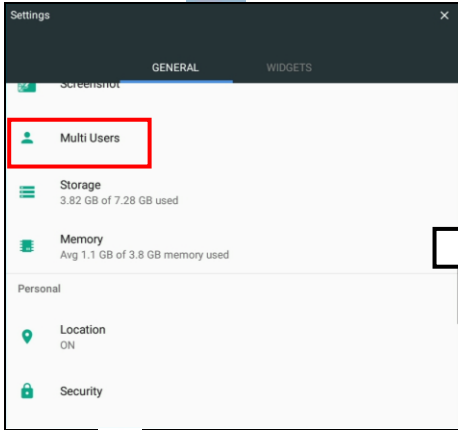

2. 點選  > 刪除。

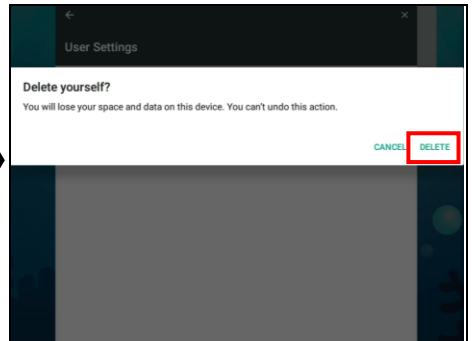
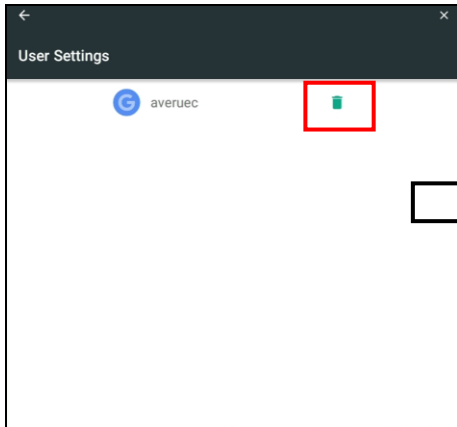

3. The system will return to the login screen.

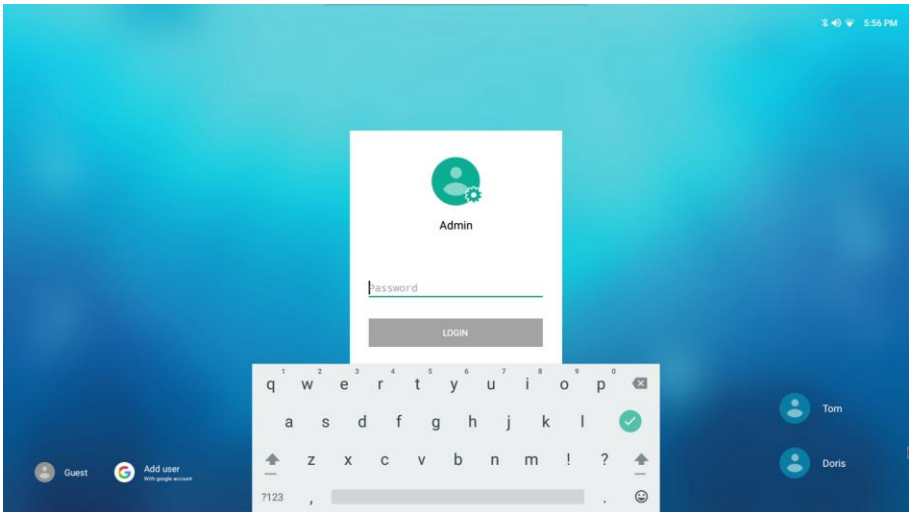

Login with Card

Enable the Login with Card

The AVer CB-310 system allows a user to use chip sensor card reader to login to AVer CB-310 system.

1. Install the card reader to USB port of your AVer CB-310 unit.

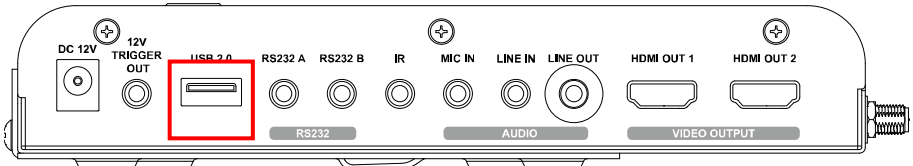
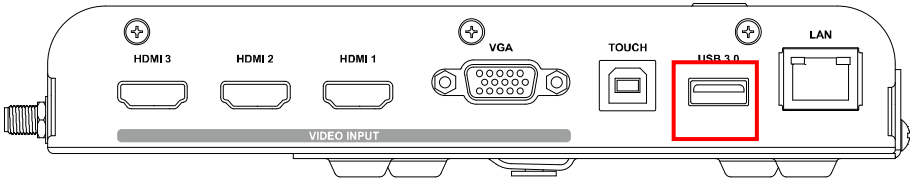

2. Select  > **Multi User** and enable "Login with card".

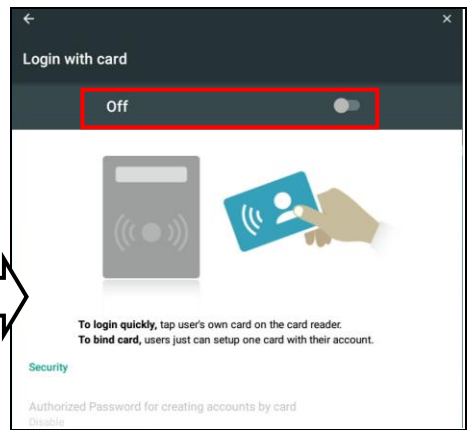
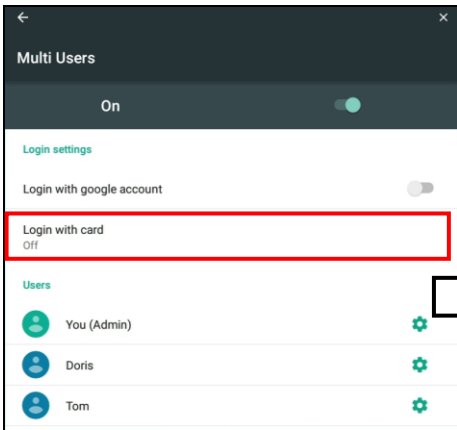

3. User needs to set a password for creating account by card. The password will be used when create an account by card. Enter the password (at least 4 characters) and re-enter the password to confirm.

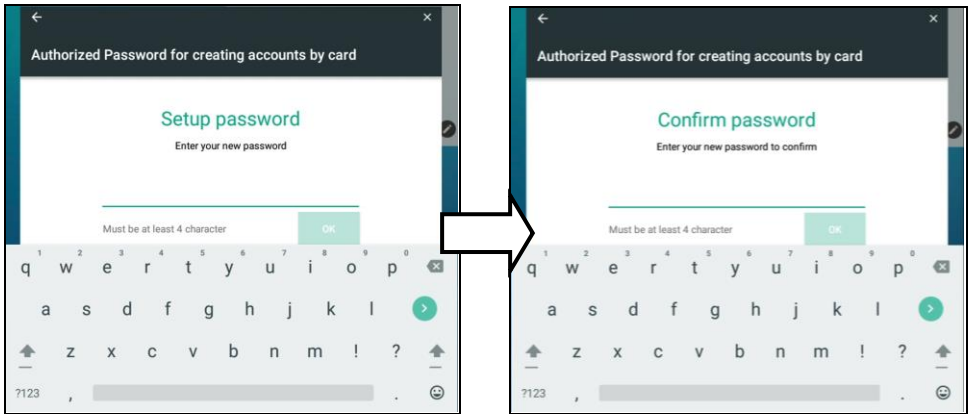

4. The system will ask the user wants to bind the Admin account with card. Select "**BIND CARD NOW**" and put the card to the card reader. If the user doesn't want to bind the admin account with the card, select "**NO, THANKS**".

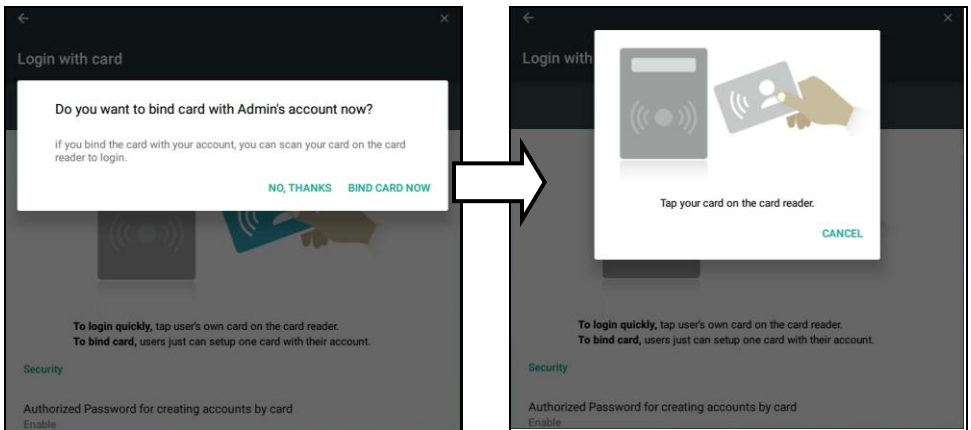

Bind the card with admin account is successful.

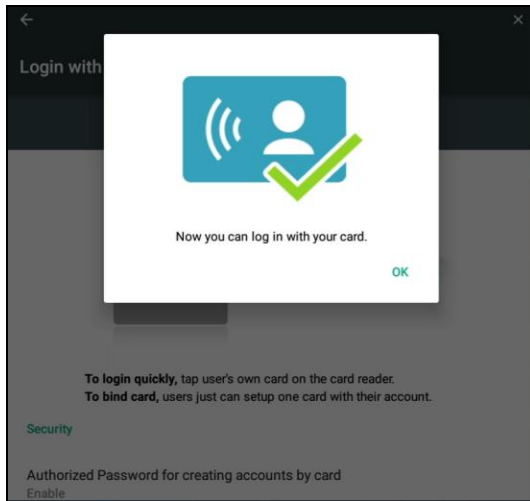

5. After enable login by card and bind the admin account with the card, user can use the card to login next time. The user should see the **“Tap card or Enter Password”** message for Admin account at login screen.

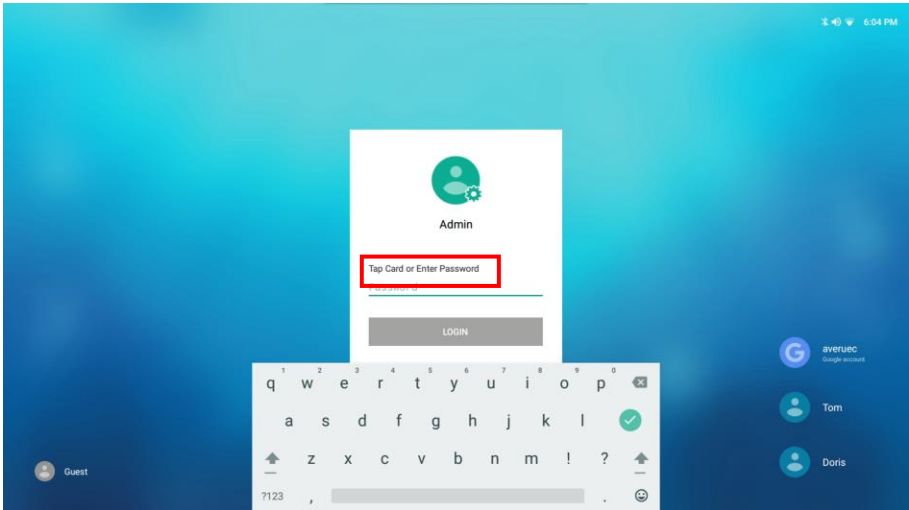

Create an Account by Card

The user can create an account by the card at login screen.

1. At login screen, put your card on card reader and select **“Add a new account”**.

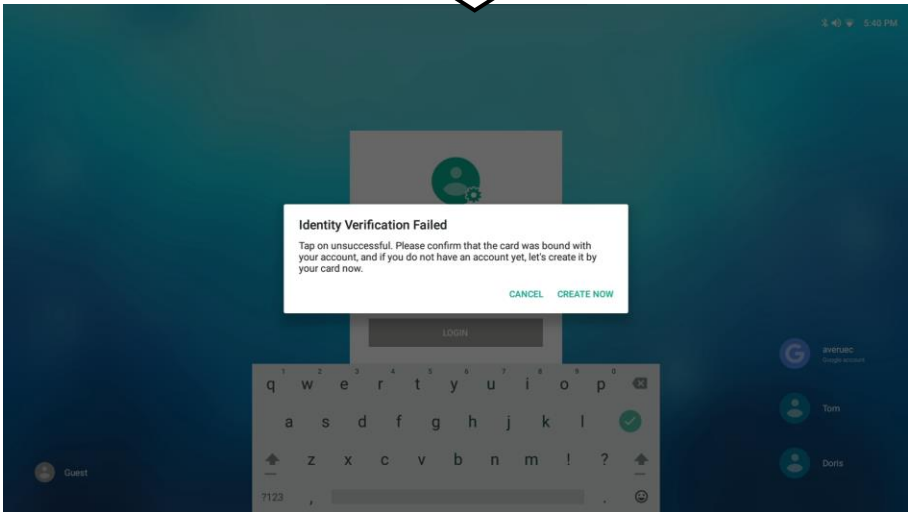
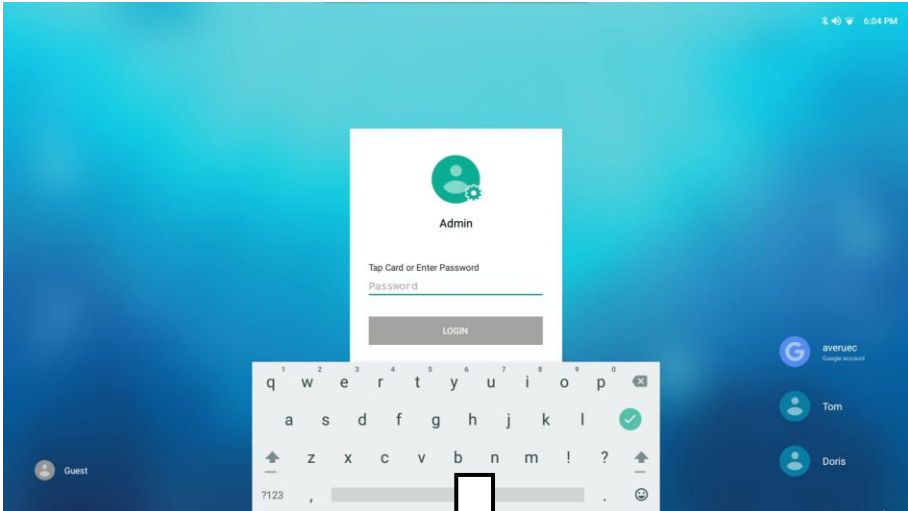

2. Enter the password that user has set for creating account and select **“START”**.

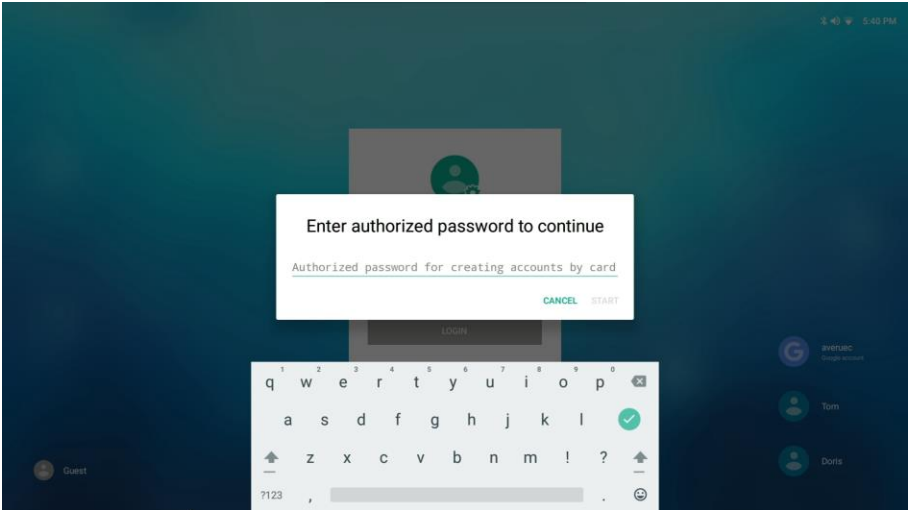

3. Enter the name for the account and select **“NEXT”**.

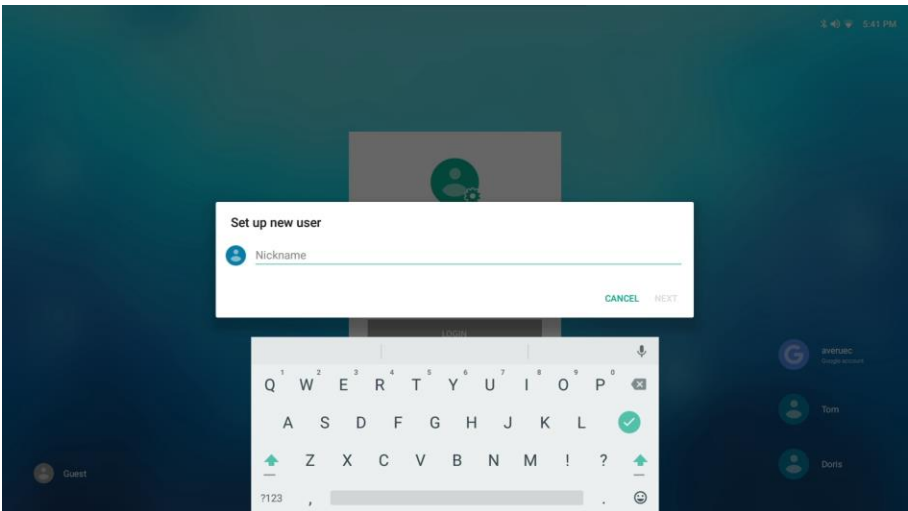

4. Set the password (at least 4 characters) for the account and select “NEXT”.

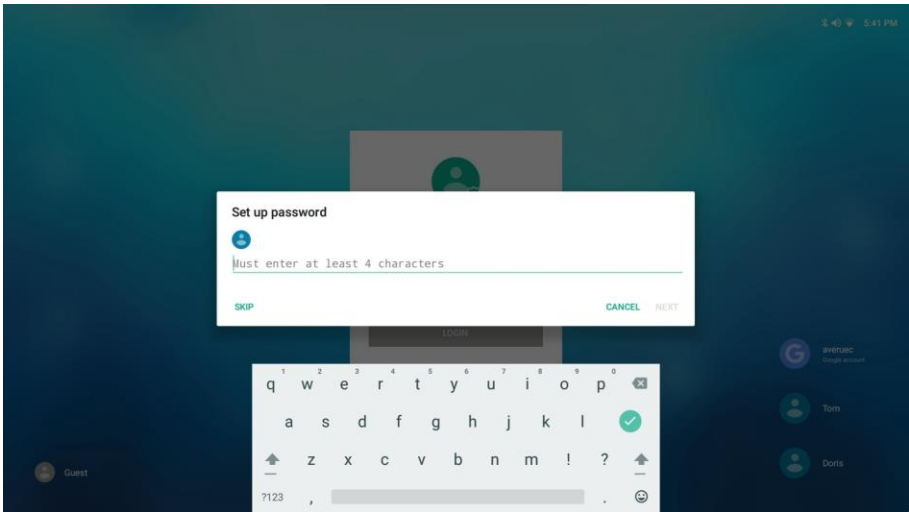

5. Put your card on the card reader and select “OK”.

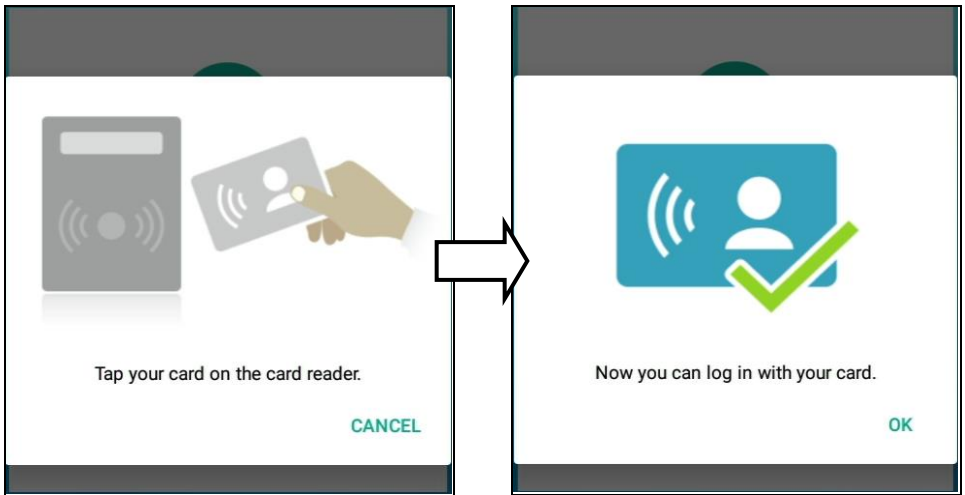

6. The account has created. The user can see the account in the list on the login screen. To login, select the account and put your card on the card reader.

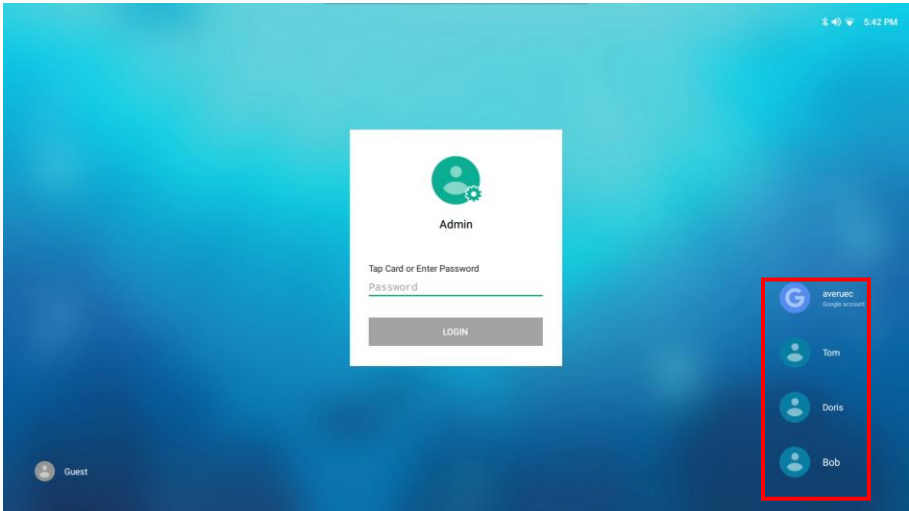

7. For the first time login time, follow the on-screen instruction to complete start-up. The system will ask user to change the account password. If user wants to change the password, select “**RESET PASSWORD**”, or tap “**NO, THANKS**” not to change the password.

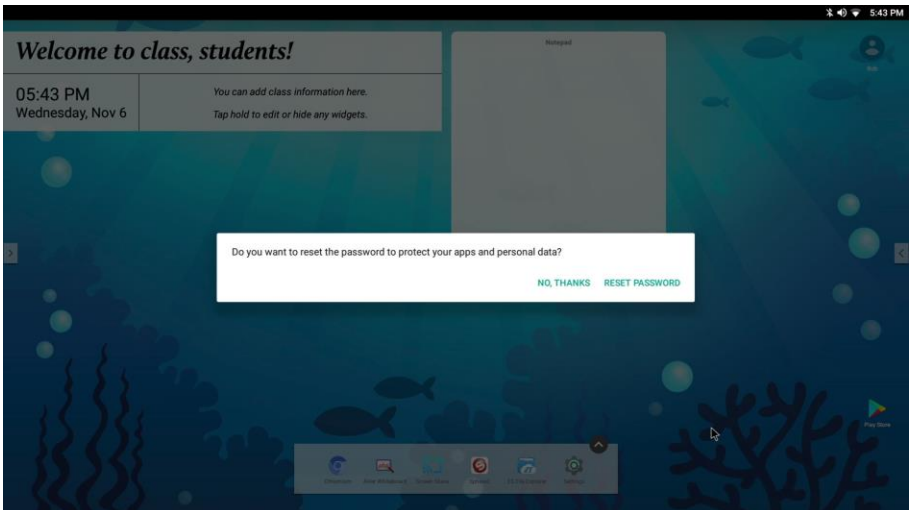

Change the Password of the Account

The user can change the password of the account.

1. After login, select  > **Multi User** >  of your account (ex: You(Bob)).

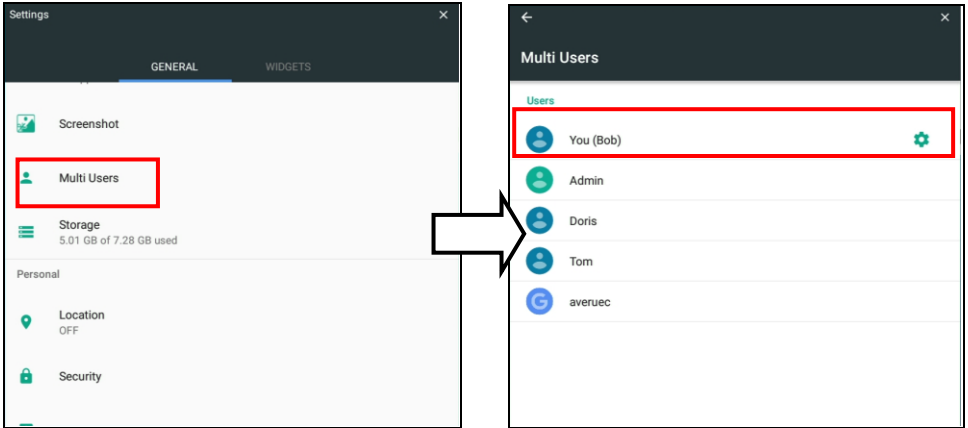

2. Select **“Password”** and enter the current password.

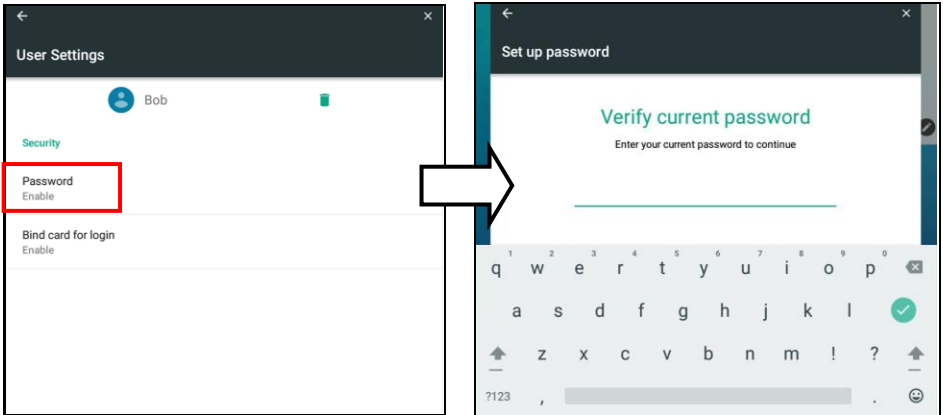

3. Select “**Enable**” to change the password.

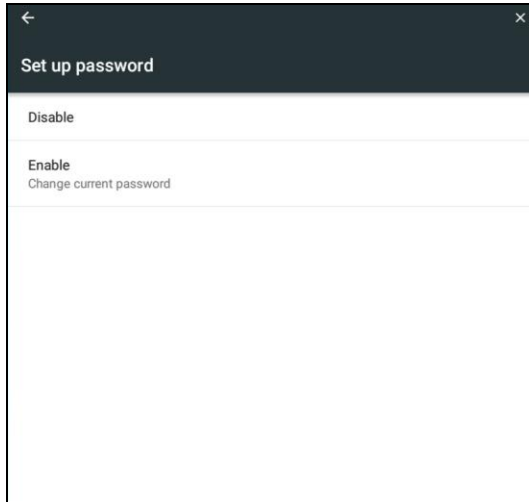

4. Enter the new password and re-enter the password to confirm.

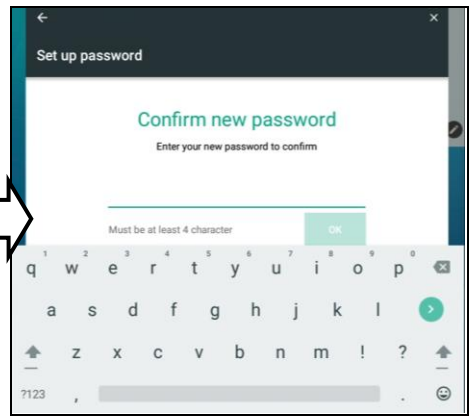
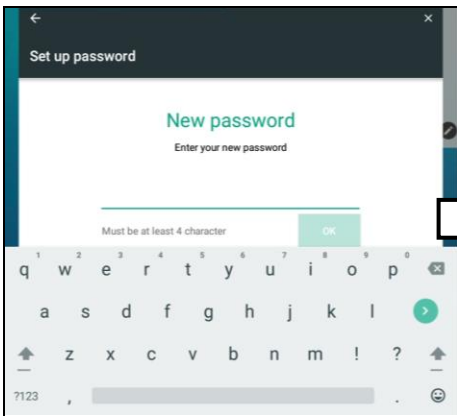

Bind the Card for login

User can bind the card on the exiting account.

1. After login, select  > **Multi User** >  of account (ex: Doris).

[Note] User can login within admin account or user account.

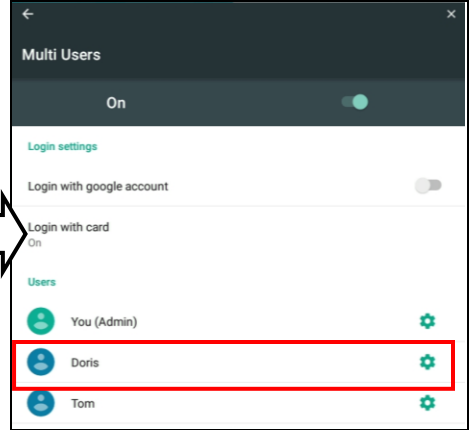
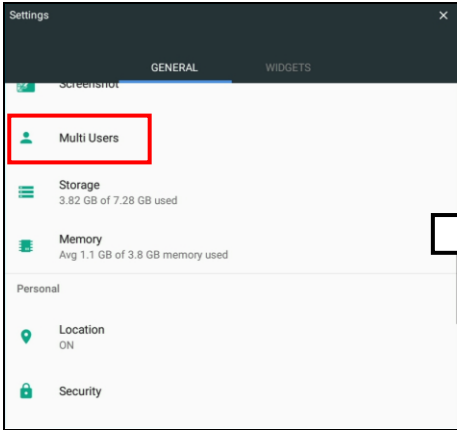

2. Select “**Bind card for login**” > **Enable**.

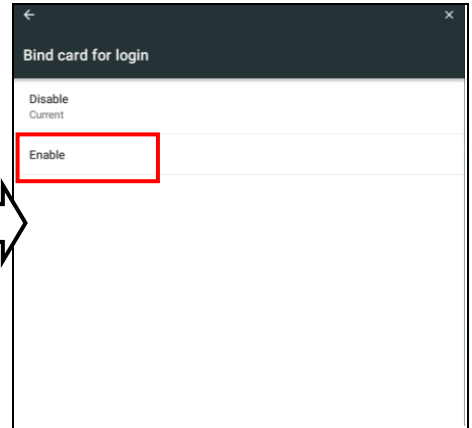
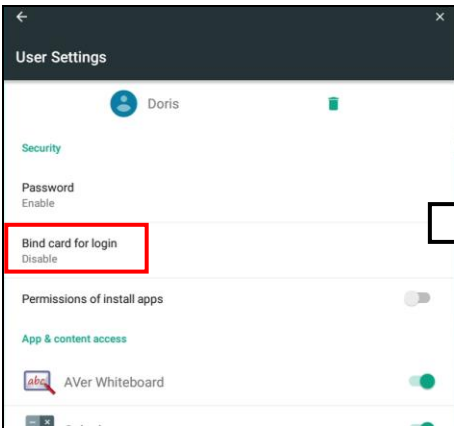

3. Put your card on card reader. When successful message display, the card binding is completed.

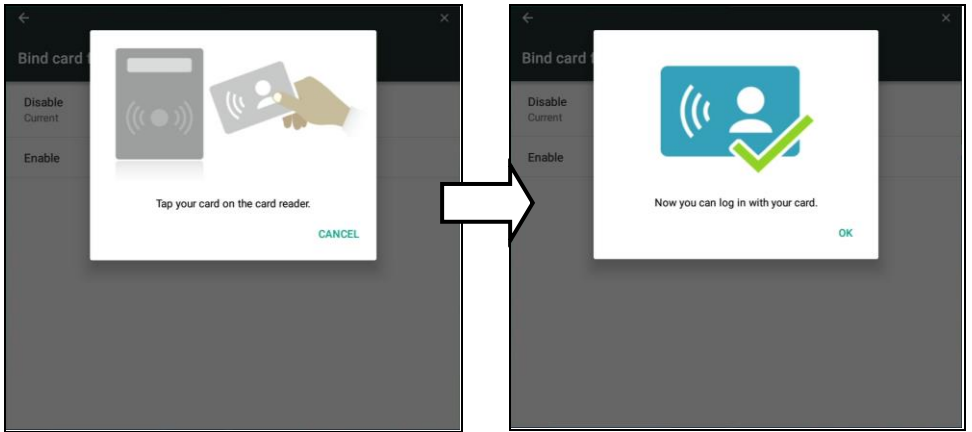

Delete the Account

The user can delete the account.

1. Login with your user account, select  > **Multi User** >  of your account (ex: You(Bob)).

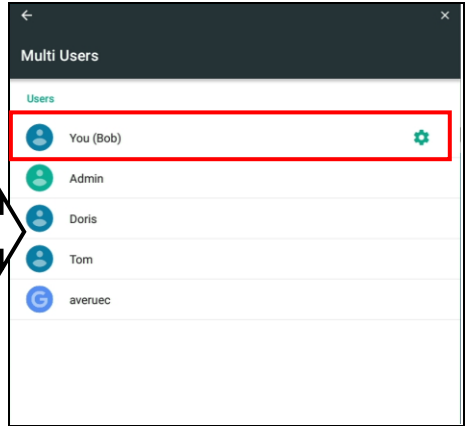
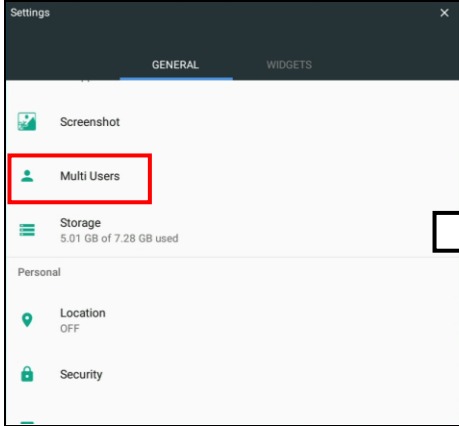

2. Select  > **DELETE**

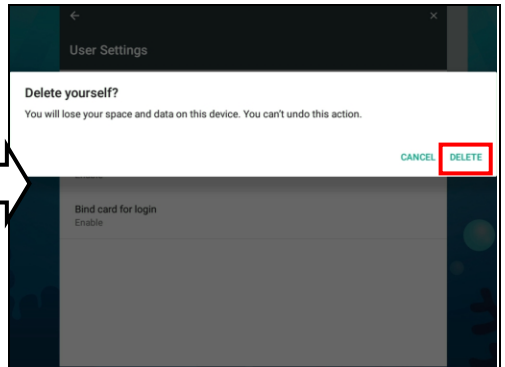
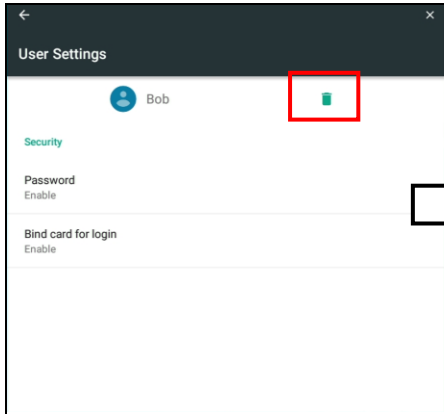

3. The system will return to the login screen.

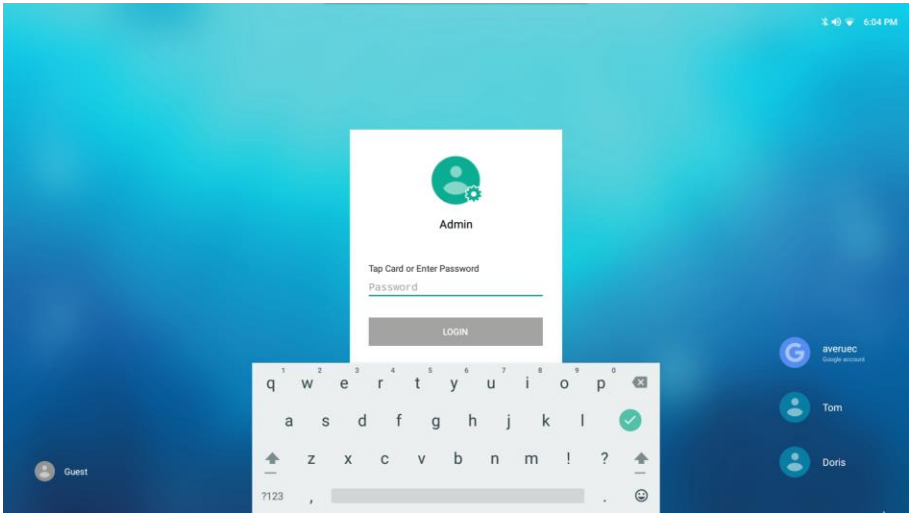

Cloud Storage

Create the google drive on AVer CB-310 for file accessing and storage.

Build an Account

1. Open the ES file explorer from All apps on the main screen.

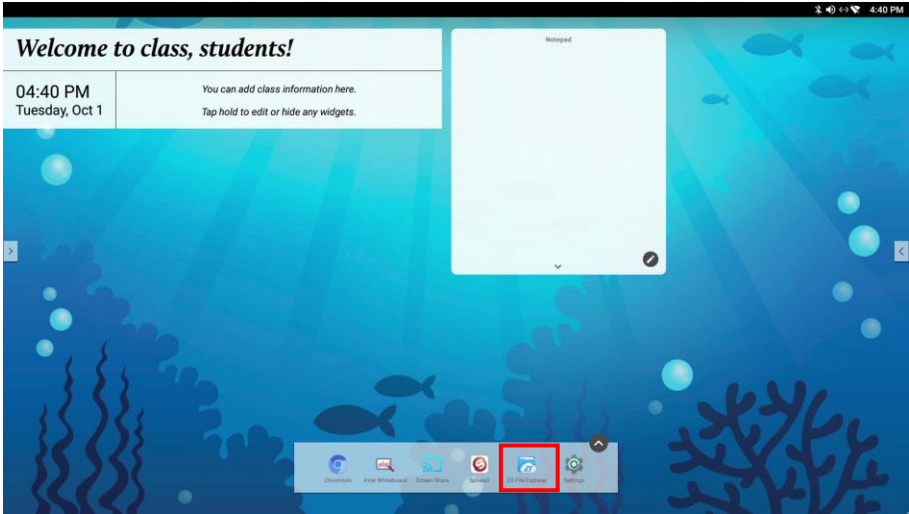

2. In ES file explorer screen, select **Network > Cloud Drive**.

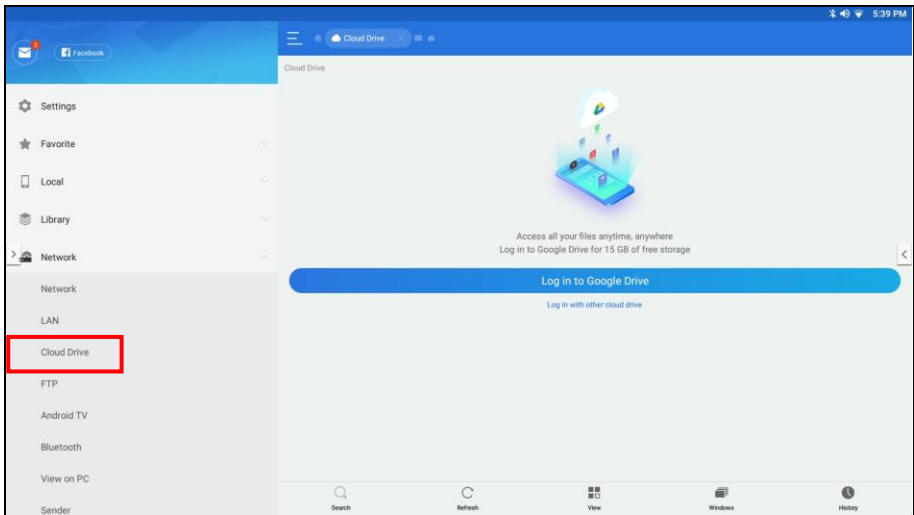

3. In Cloud Drive screen, select “**Log in to Google Drive**”.

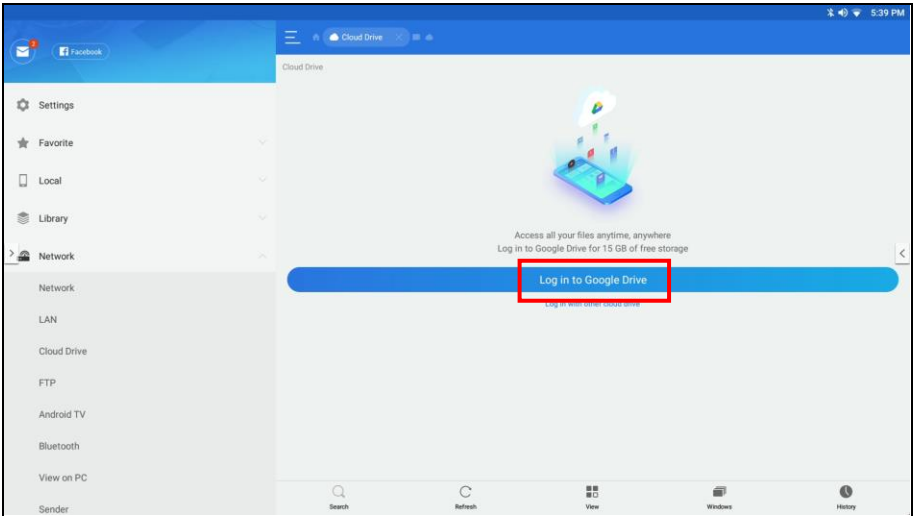

4. Login with your google account, then, select “**Next**”.

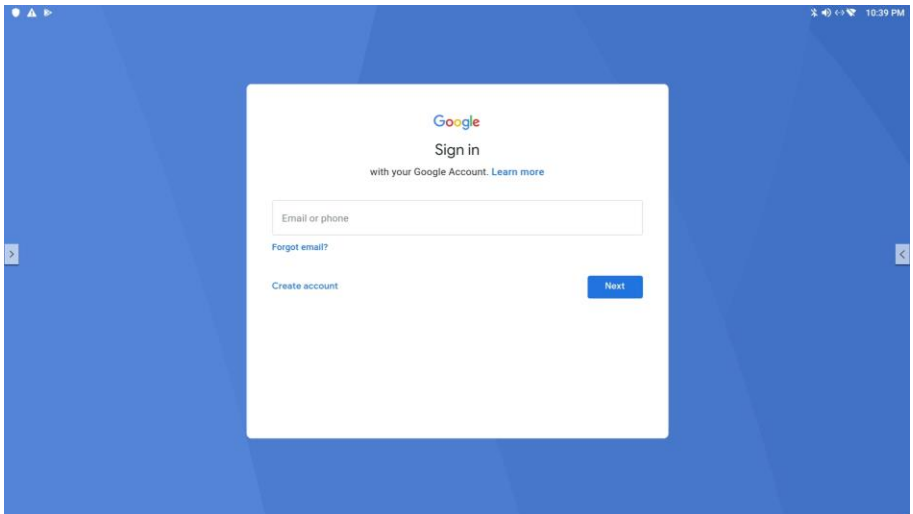

5. Enter your Google account's password and select **"Sign in"**.

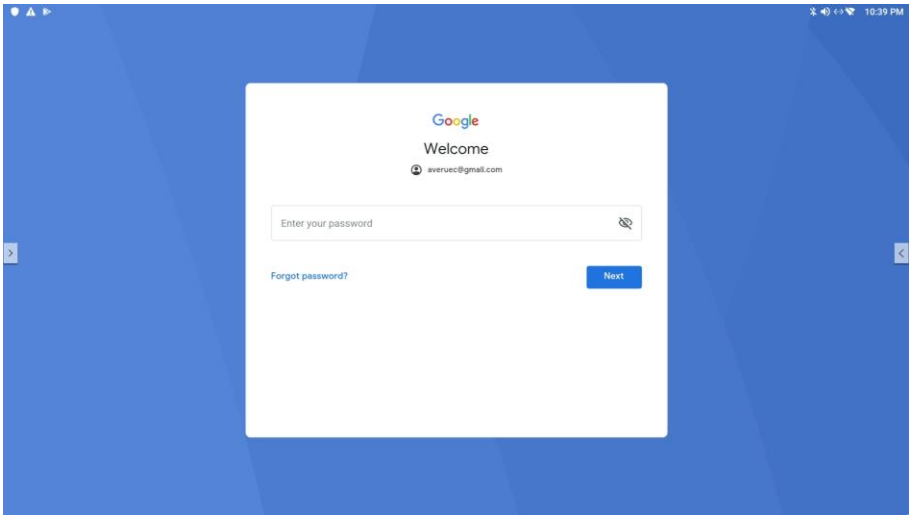

6. After sign in, the google drive is build.

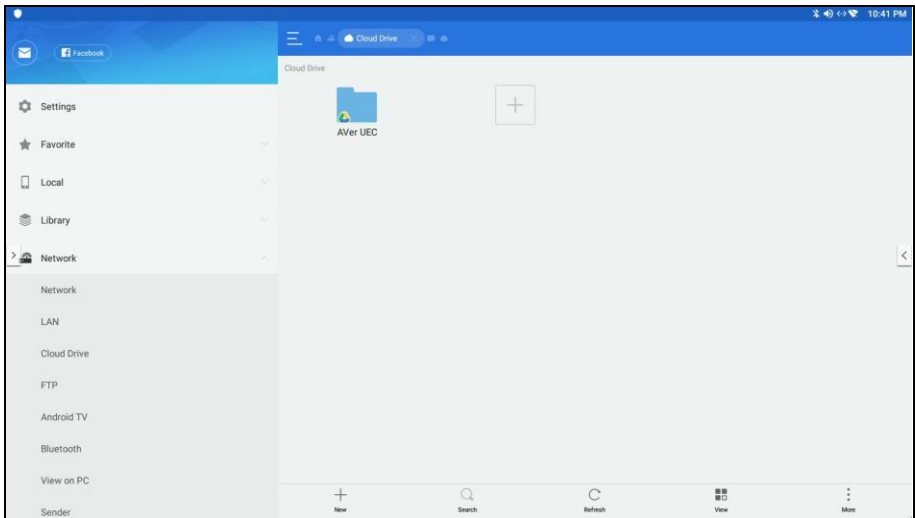

7. For another cloud account, click “New” or “+”.

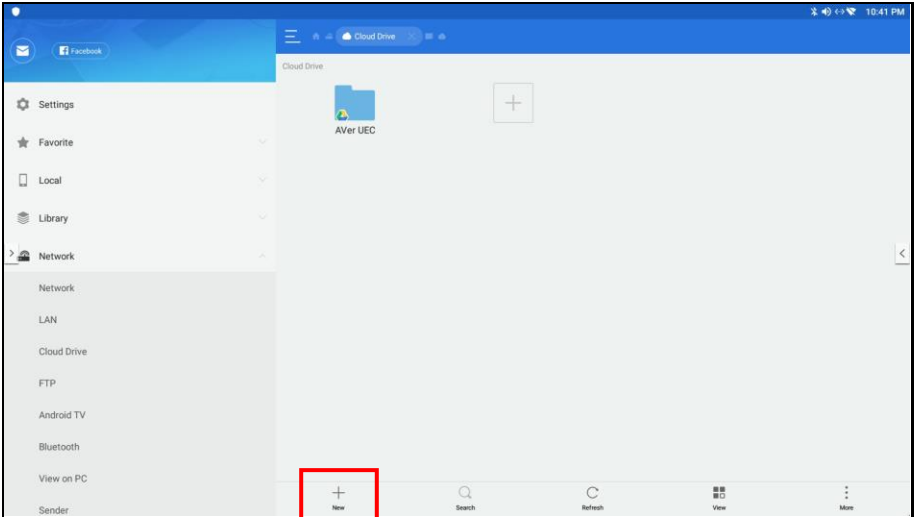

8. Then, select “Gdrive” and follow on-screen instruction to build the cloud drive.

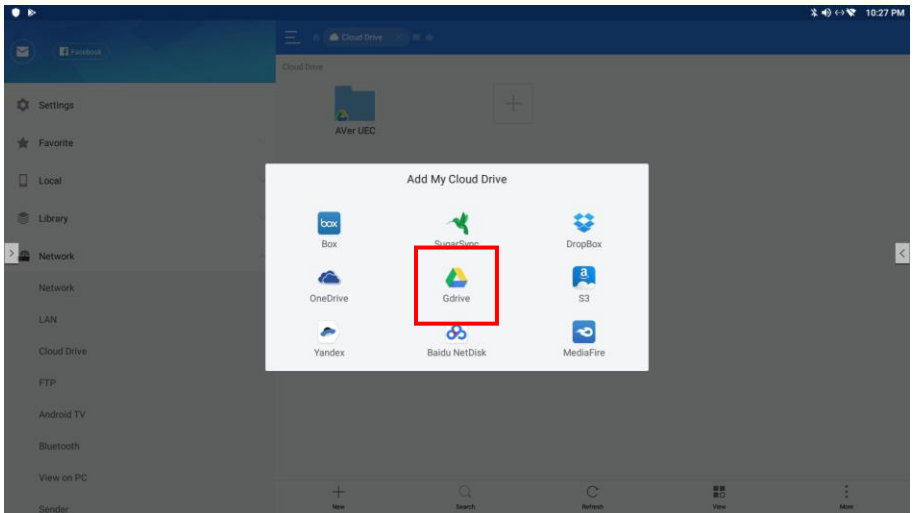

Open a File from the Cloud Storage

1. Open the ES file explorer > Netw ork > Cloud > your Google drive account.

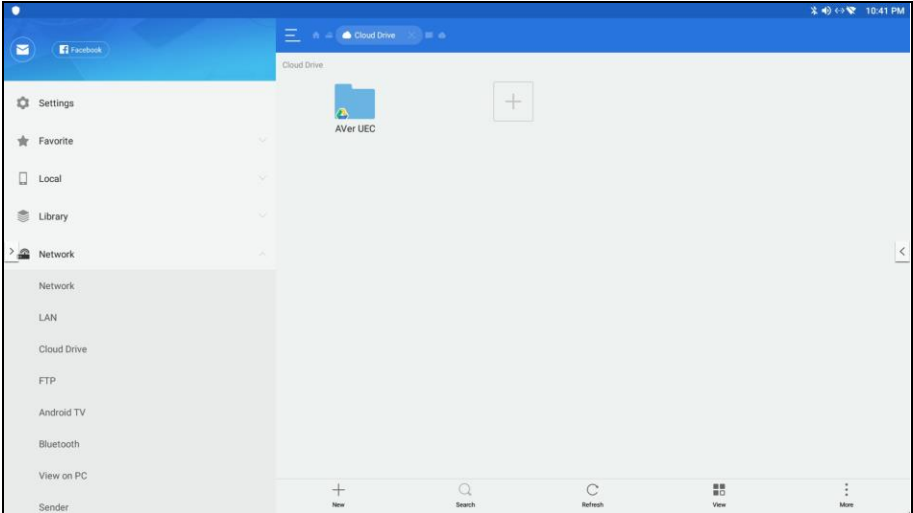

2. Select the file from your google drive. Wait for selected file will be downloading to local disk to open.

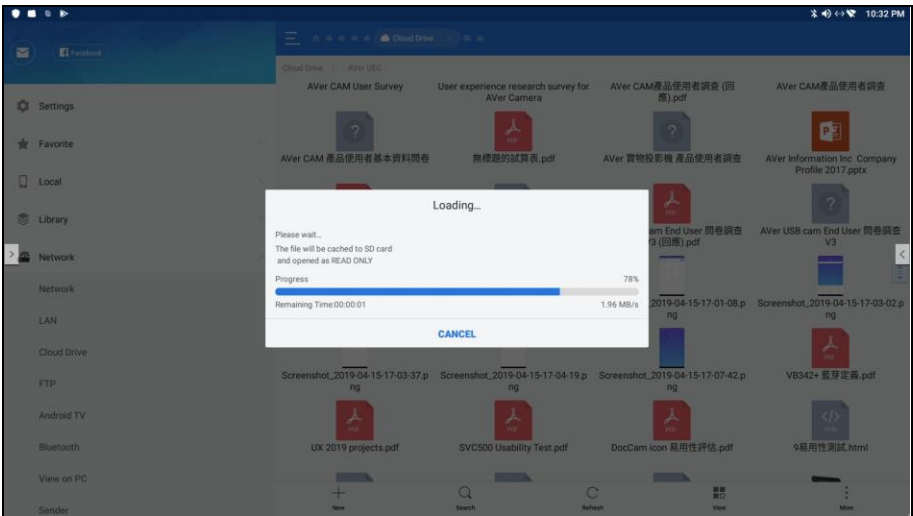

3. The file is opened by OfficeSuite.

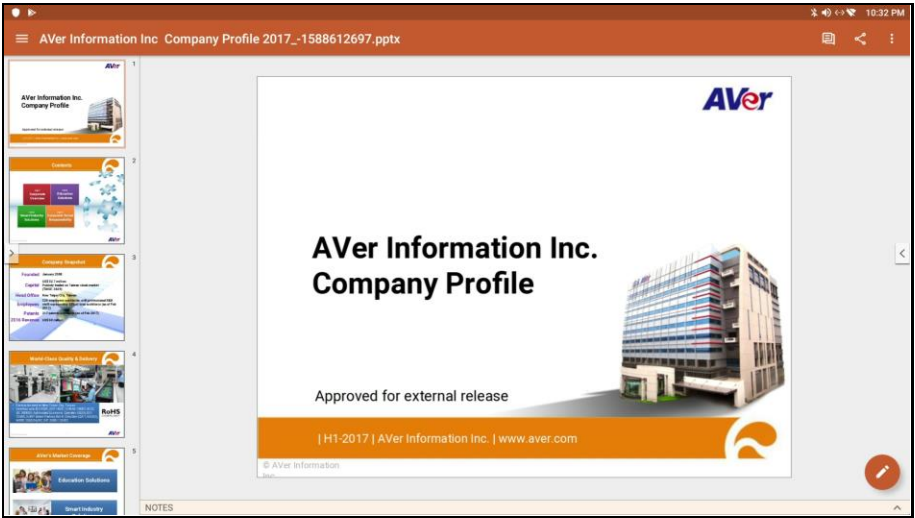

4. If file is a *.ppt file. Select  > **Start slide show** can switch to slide show mode.

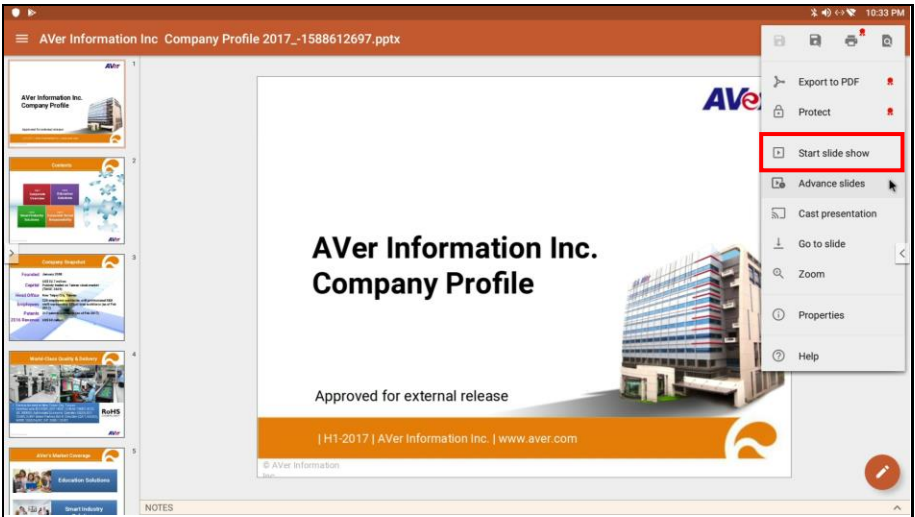

5. Select  can edit the file.

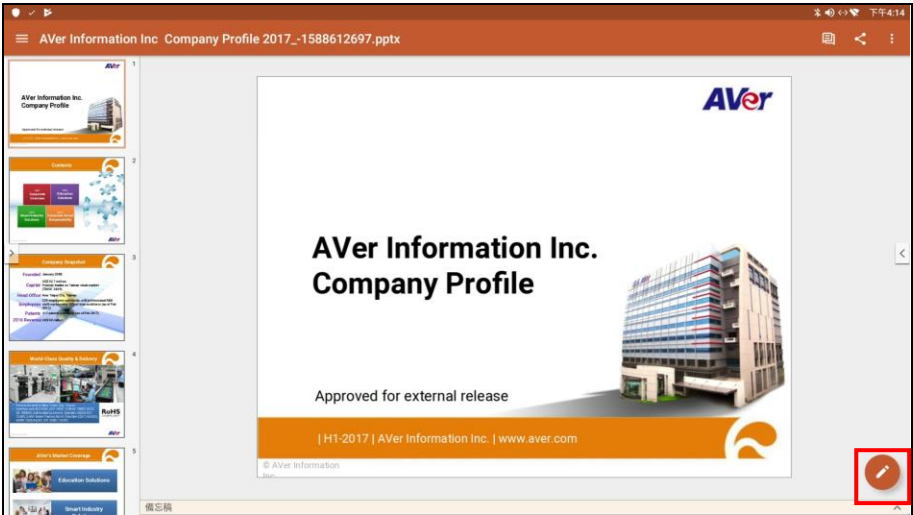

6. Edited file can be saved as PDF file. Select  to save the edited file.

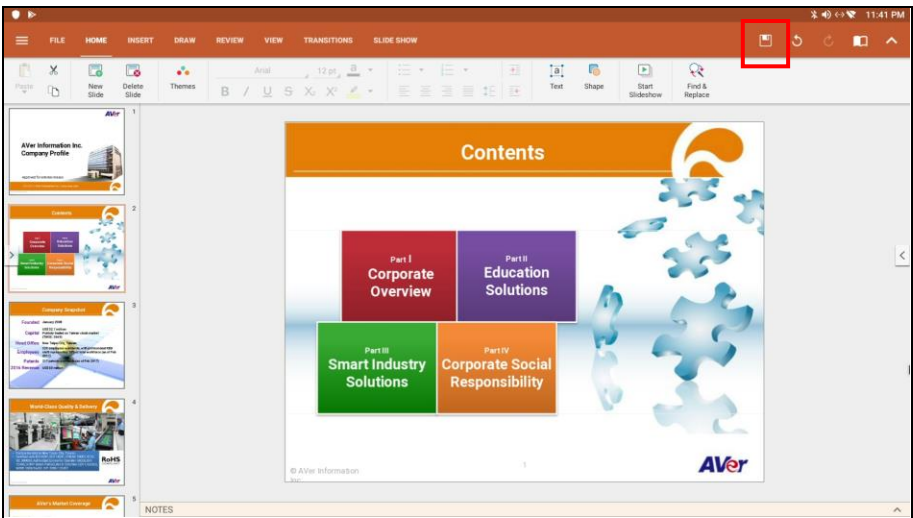

Set Password for ES File Explorer

Set the password to protect ES File Explorer.

1. Open ES file explorer and select “**Settings**”.

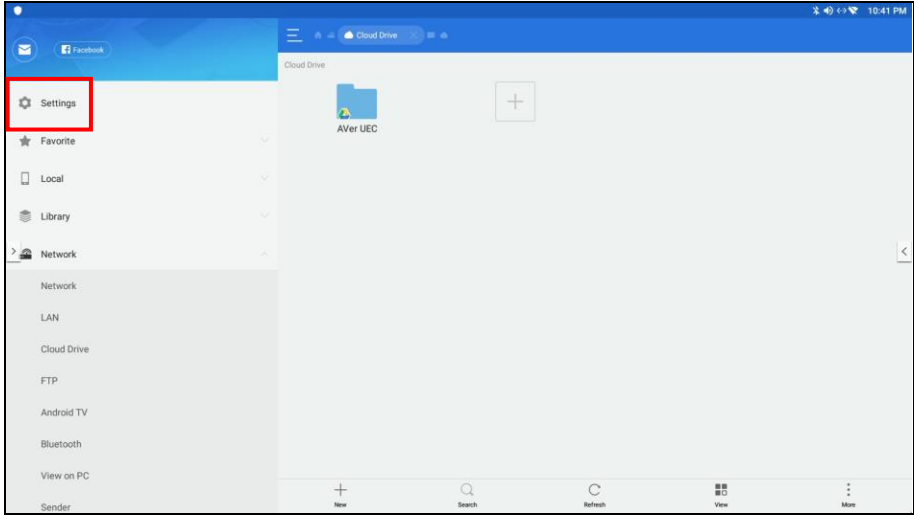

2. Select “**Password Settings**”.

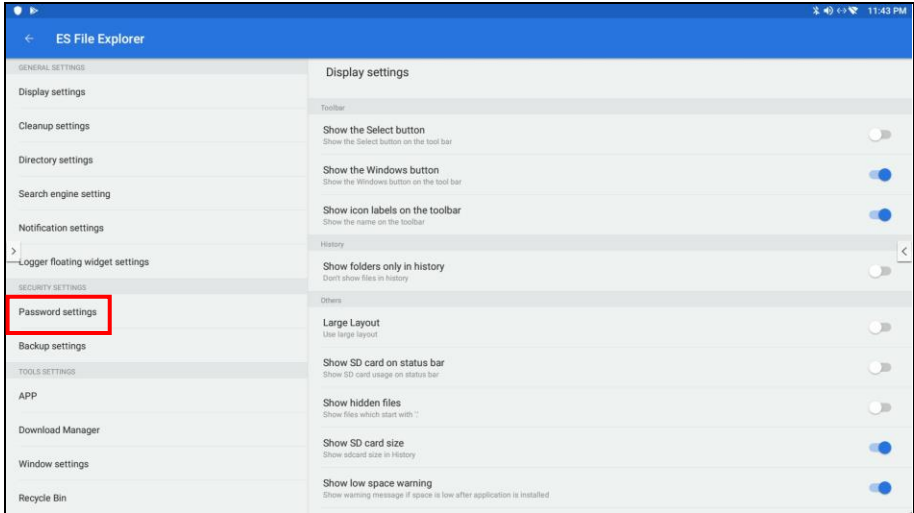

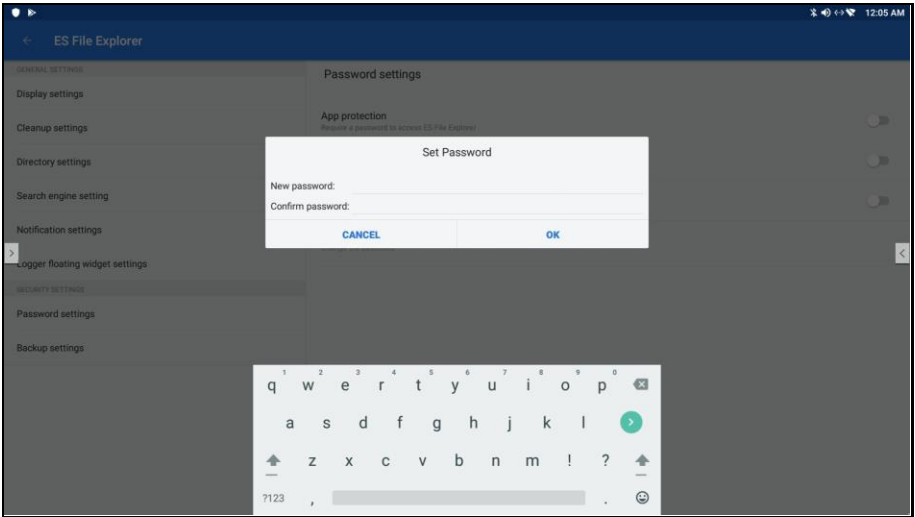

3. Enter the password and re-enter password to confirm. Then, select “OK” to complete.



Whiteboard

Select  on main screen to call out Whiteboard application.

Tutorial

For the first time use, the tutorial will guide the user how to use whiteboard; select  to go next step, select  to back previous step. Select **TRY** the tutorial will close, select  can continue the tutorial.

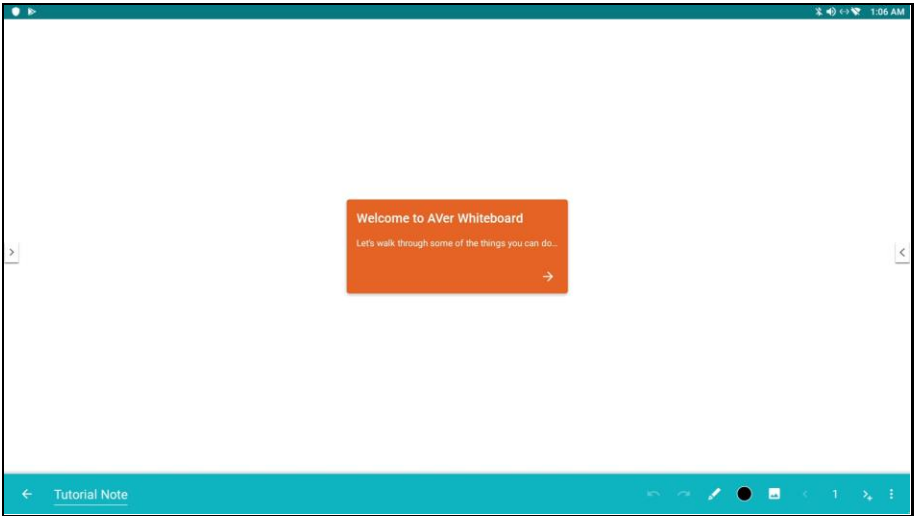

If user wants to view the tutorial again after tutorial, select the “**VIEW TUTORIAL**” at main page of whiteboard. Select “**DISMISS**” will close the tutorial selection.

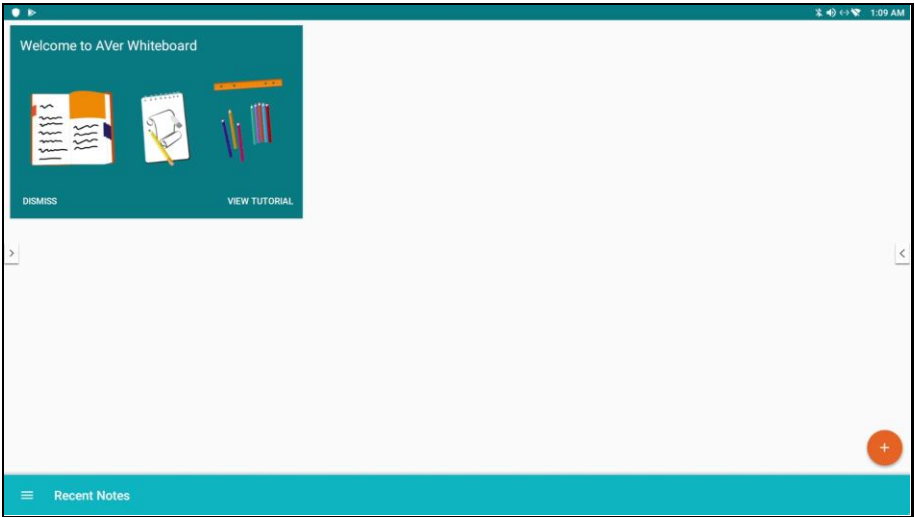

Note Format

The note page has different format and user can choose the proper format to use.

1. Select  and select "**Note**". Also, user can select "**Default note**". The default note will be a blank page.

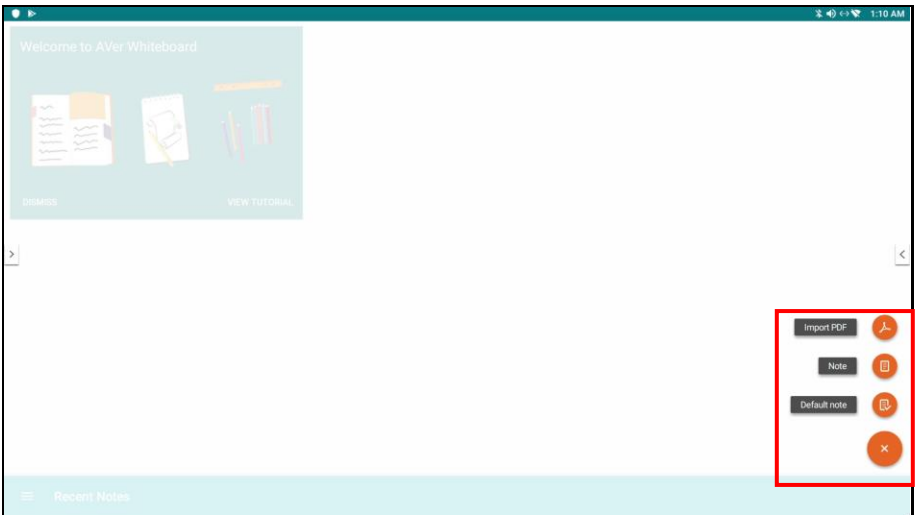

2. The note formats are category in Standard, Grid, Math&Engineering, Music, Sports, and Planners&Lists. Choose the proper note format to use.

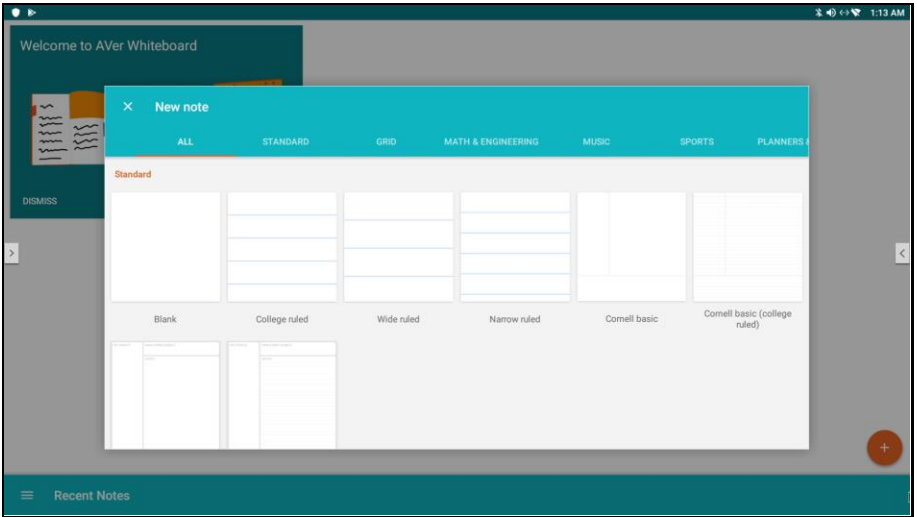

Import PDF

User can import the PDF file from external USB pen drive, local (AVer CB-310 system), or Google drive into whiteboard.

1. Select  and select "Import PDF".

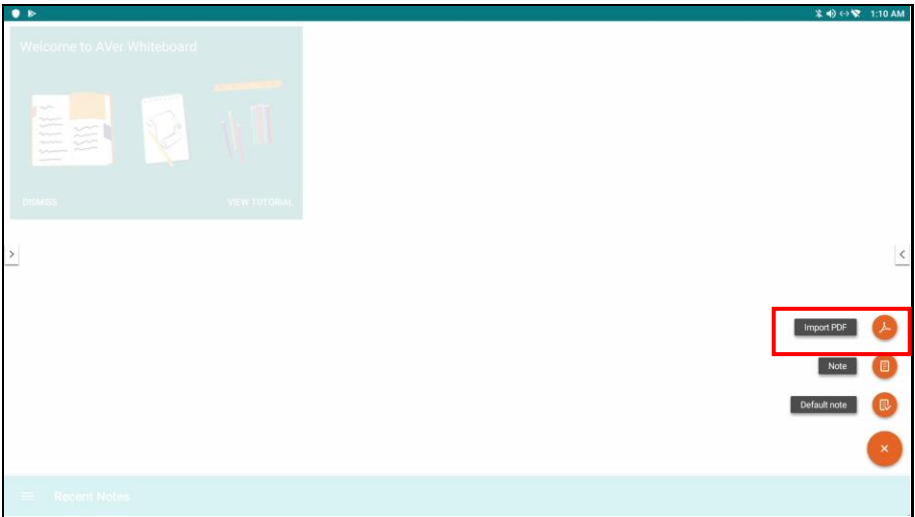

2. Locate the PDF file. If user wants to open the PDF file from Google drive, select **ES file explorer** > select the path > your Google drive.
3. The imported PDF file is displayed on whiteboard screen.

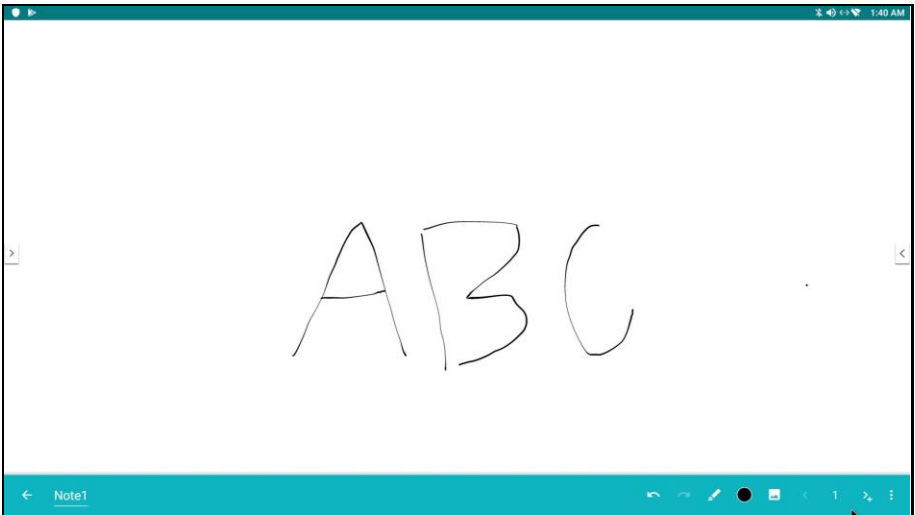

Save the PDF file to Google Drive

[Note] The Google drive must have built on AVer CB-310 (See also chapter of Cloud Storage).

1. In Whiteboard note page, select  > **Export**.

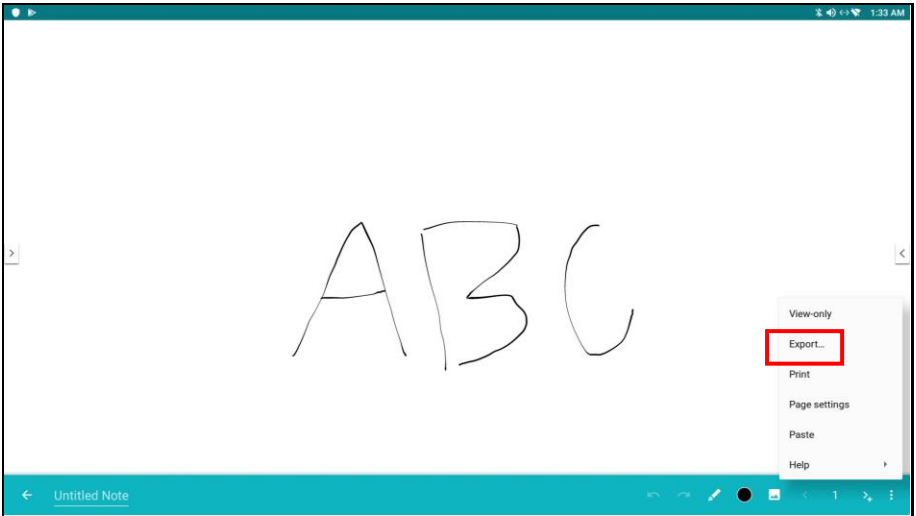

2. Select "Pages" is "Entire note" and "File format" is "PDF". Next, select "Share".

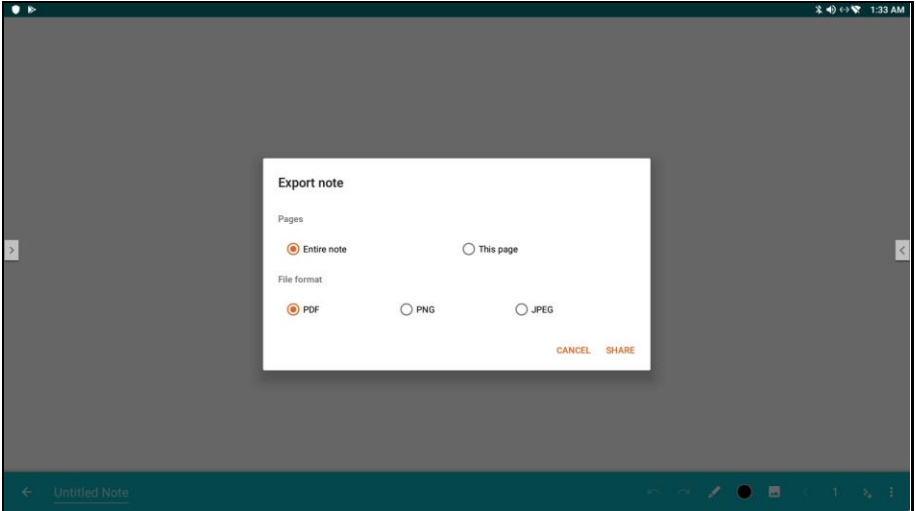

3. Select “ES Save to”.

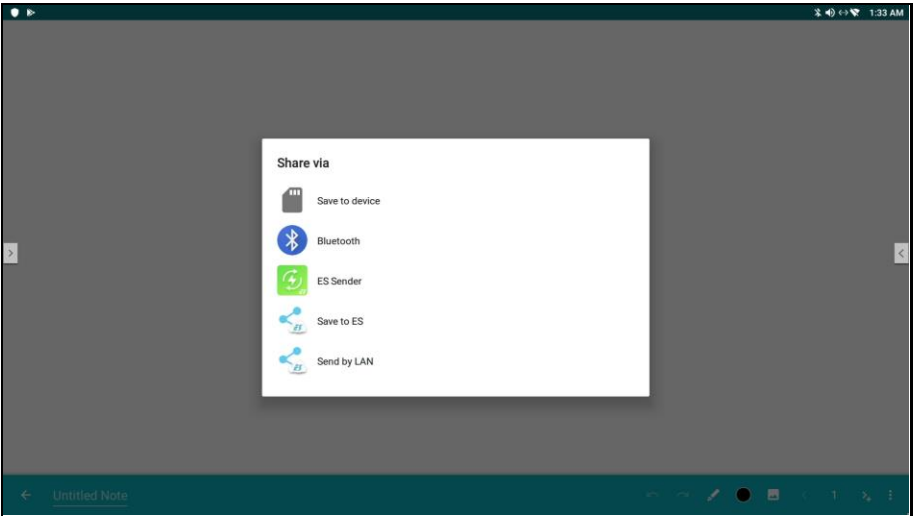

4. Select ← to go to main root directory. Then, select your Google drive.

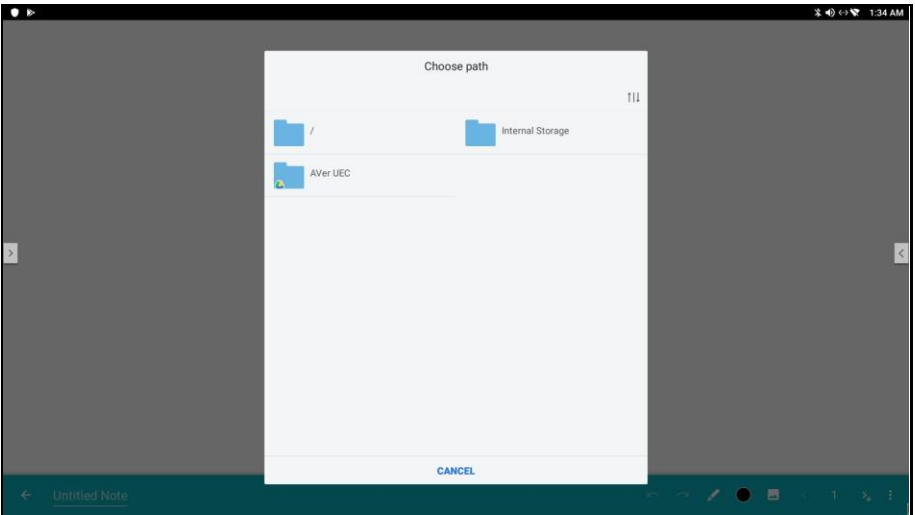

5. Select the folder and select "**Select**". The note page will be saved to your Google drive.

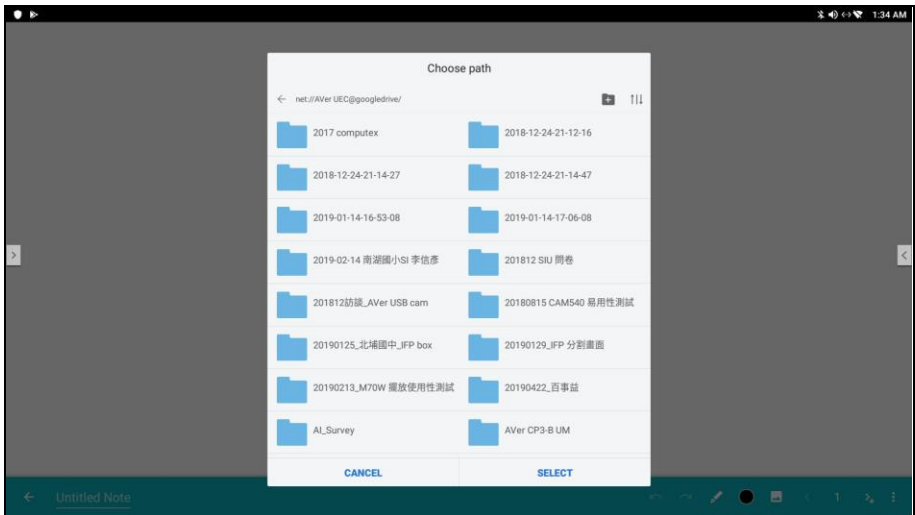

Change Name of the Note

User can rename the note.

1. Select the note name is located at left bottom corner.



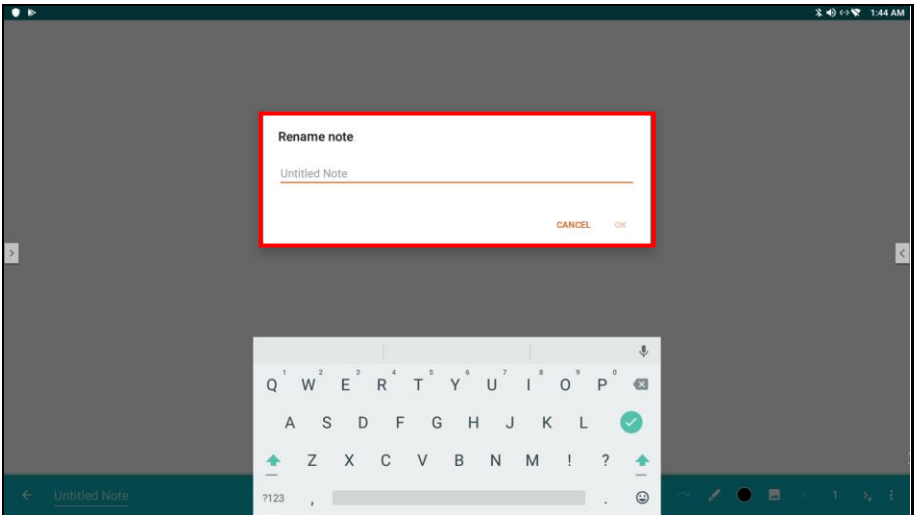

2. Enter the new name of the note and select **OK** to confirm.

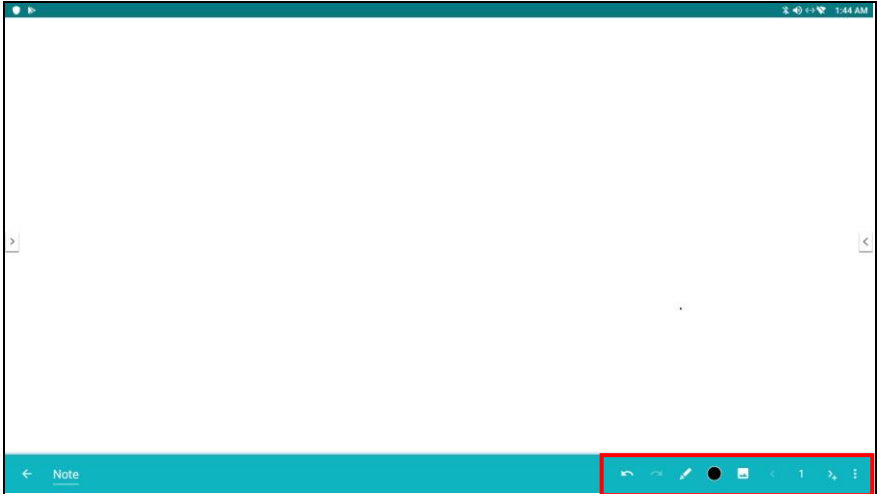

Using Whiteboard

The Whiteboard function tools are described in following.





 /  : Undo and redo the actions.

 : Pen function includes pen, eraser, mark, shape, and text function.

 : Color selection. User can select the color of pen, text, shape, and background of note.

 (Add image): Take a picture from camera that is connected with AVerCB-310 or select an image to display on whiteboard.

 2  : Note page switching and add new note page. Click the page number will switch to page list screen. Select  to switch note page.

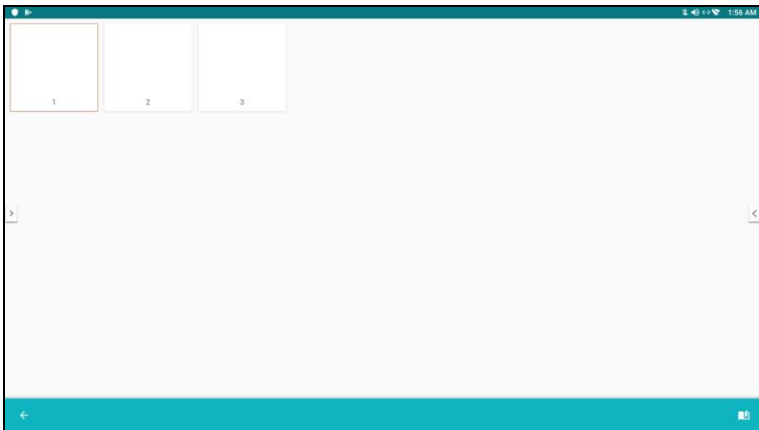

Select and hold the page number will call out note page action dialog.

- **Select all:** Select all contents on the page. After selecting, the page will change to edit mode.
- **Clear page:** Delete all contents on the page.
- **Import page:** Import a new page in front of the current page.
- **Insert PDF:** Open a PDF in the note.
- **Delete page:** Delete the current page.

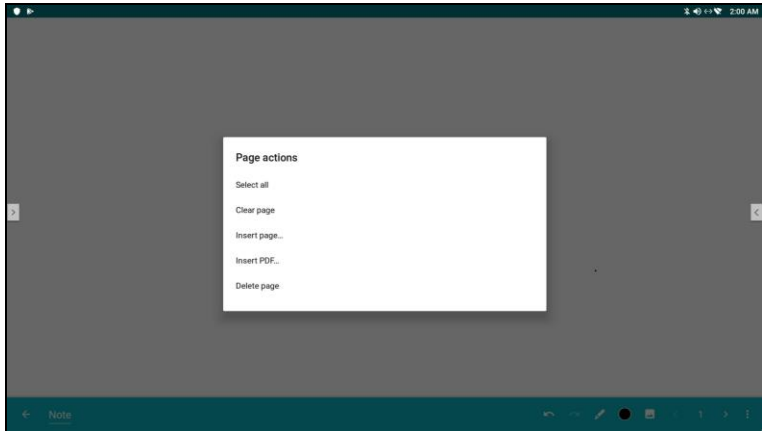

: Call out sub menu list – view only, export, print, page settings, and help.

Pen ()

The function includes pen, eraser, mark, shape and text functions.

■ Pen

Type: Pen has three types – pencil (), highlight pen (), and pen ().

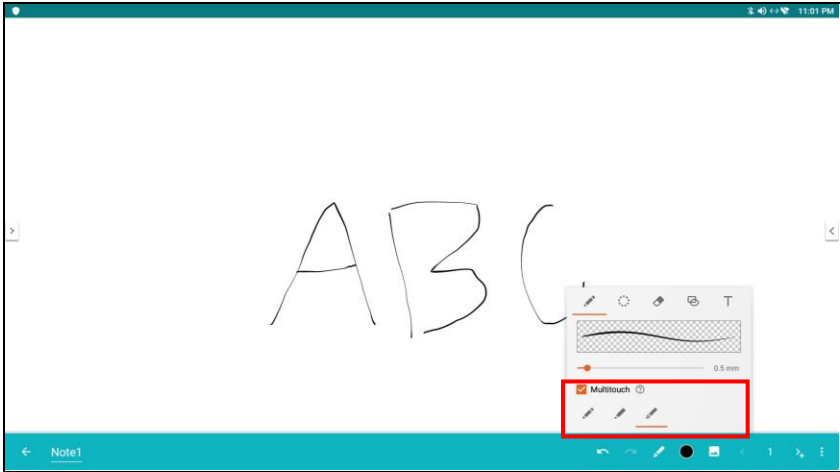

- **Multitouch:** Allows multiple users to write on the screen.
- **Pressure:** To make writing more smooth.
- **Thickness:** Adjust the thickness of pen. Move the dot to adjust the thickness.

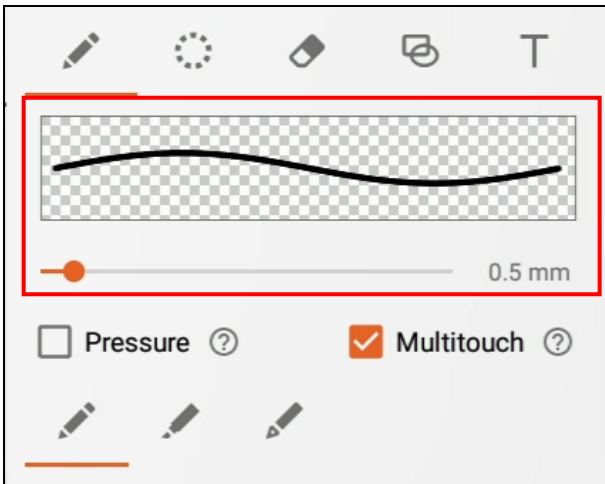

- **Color Depth:** Highlight pen can adjust color depth.

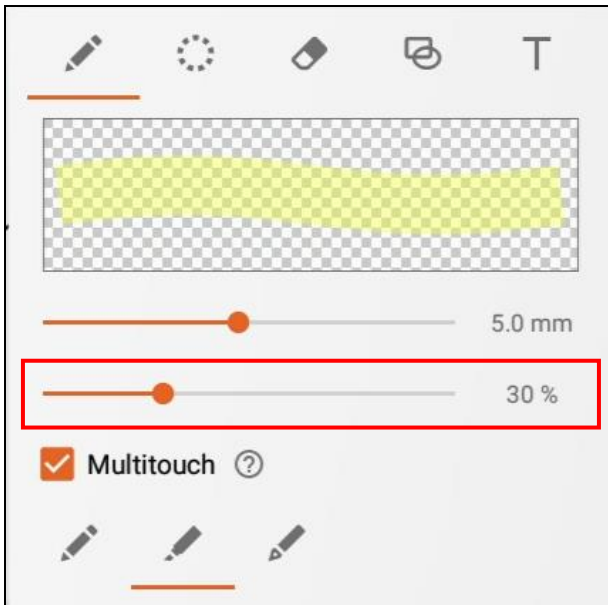

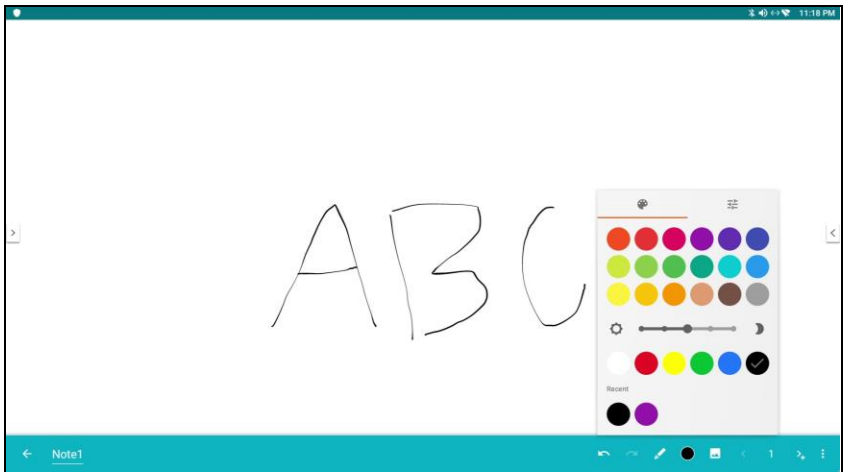

- **Color:** The color of all pens can be changed. Select the type of pen and go to Color selection (●) and select the color.



■ **Select** ()

Allows user to select the object on the screen to edit. After selecting, the screen will switch to edit mode. In edit mode, user can modify the selected object.

Select  and use finger to select the object on the screen and the screen will switch to edit mode.

In edit mode, select  can switch to whiteboard screen.

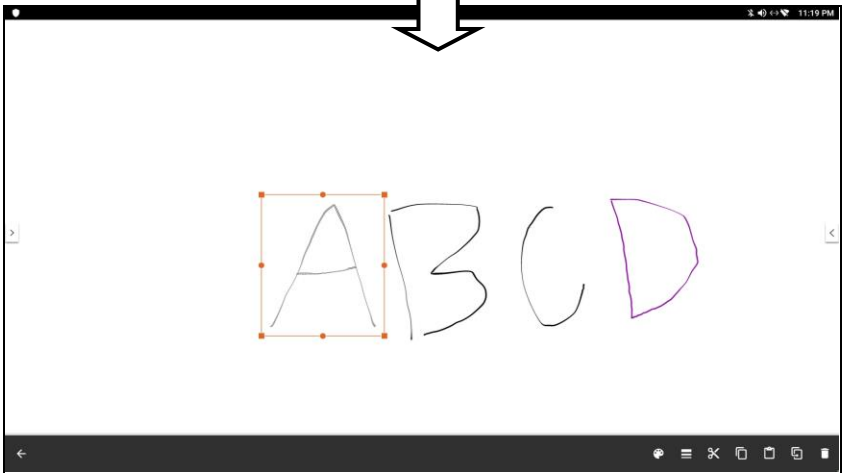
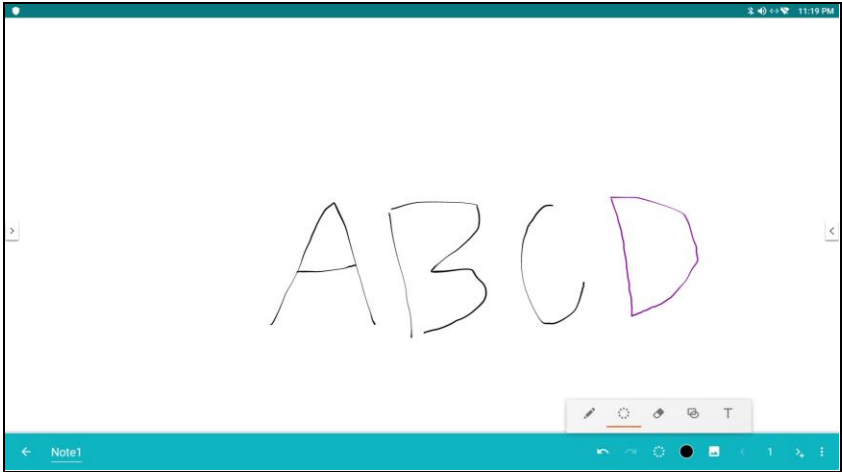





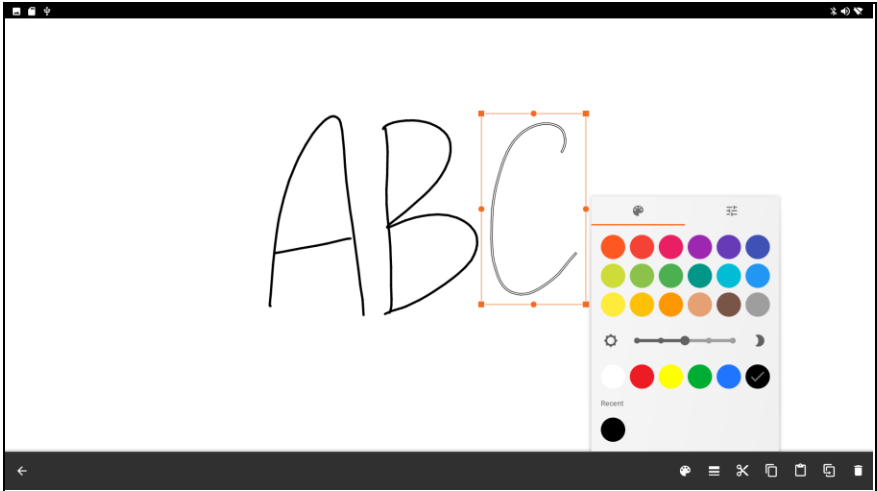

In edit mode, user can perform the following actions.

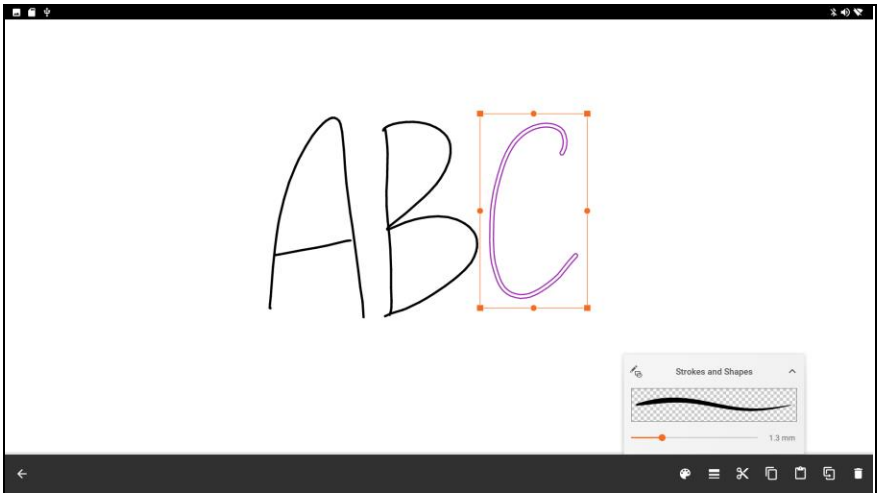
-  : Change the color of selected object.





-  : Change thickness of strokes and shapes.



-  : Cut the selected object. The cut object can be pasted on the note page. Select  to paste.
-  : Make a copy of selected object. Select  can paste the copy object on the note page.
-  : Paste the cut or copy of the selected object.

-  : Duplicate the selected object. The duplicate object will paste on note screen immediately.

-  : Delete the selected object.

■ Eraser 

To clear the handwriting or drawing on screen as required.

-  : Clear large area.

-  : Clear part by part.

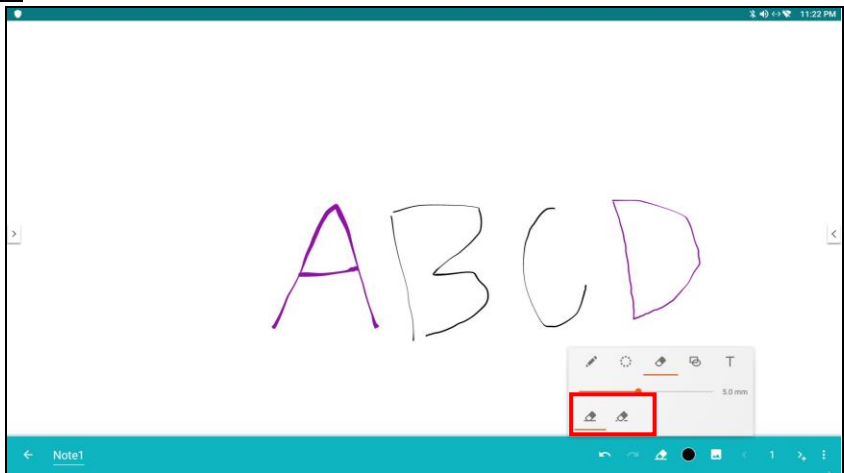

■ Shape ()

Draw the shape object on the note page. Shape objects are included line, square, and round. Move the dot to adjust thickness of the shape object.

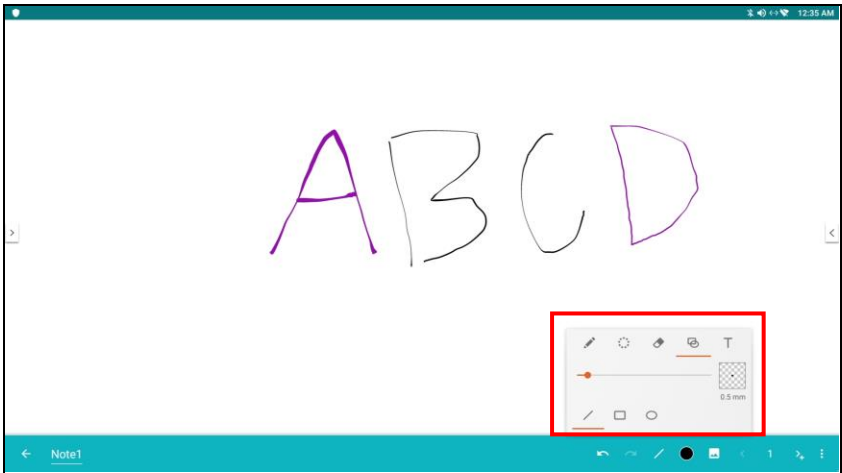

■ Text ()

Type the text on the note page.
Move the dot to adjust the font size of the text.

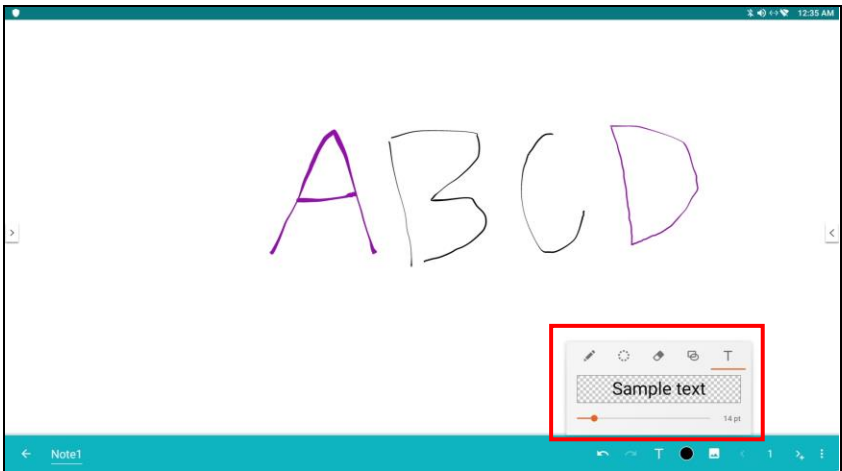

Select **T** and enter the text and select **OK**.

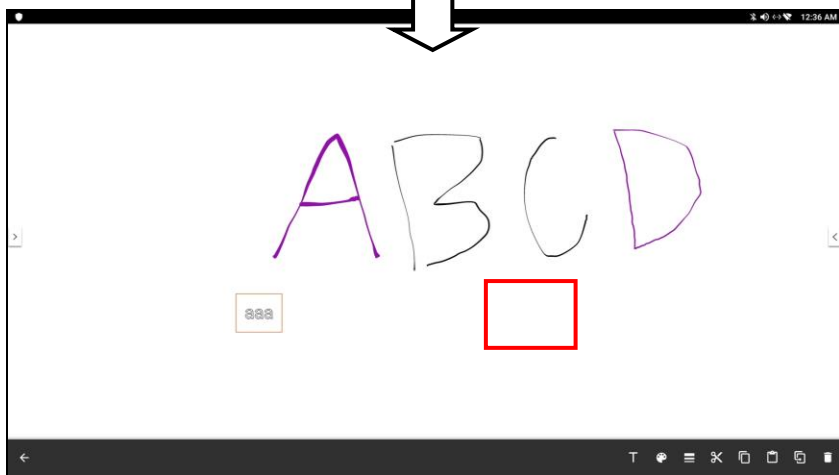
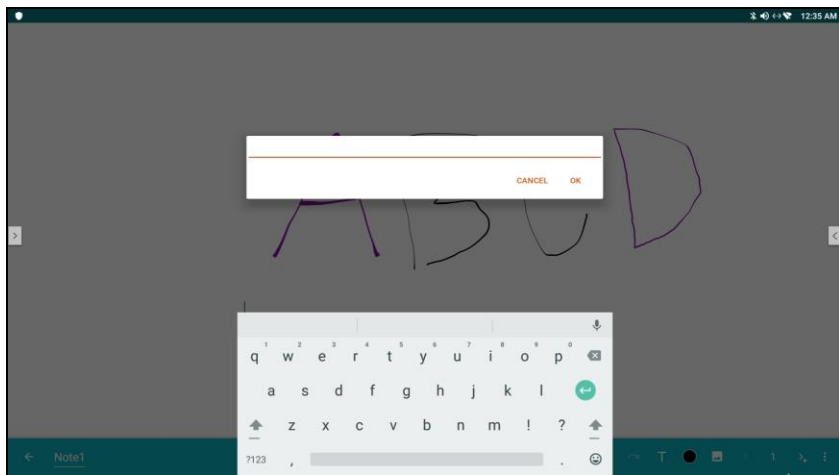

Color (●)

Change the color of pens, Shape, and text.

Select the pen, shape, or text function first, then, select ● to select the color.

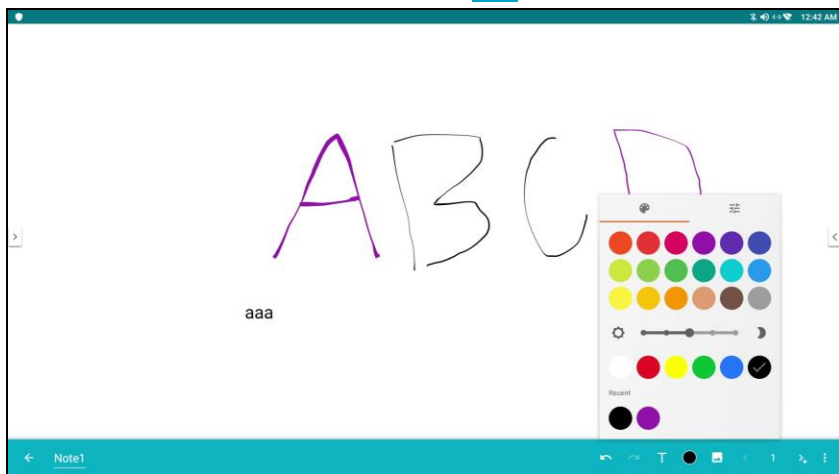

Select  can define the color on your own.

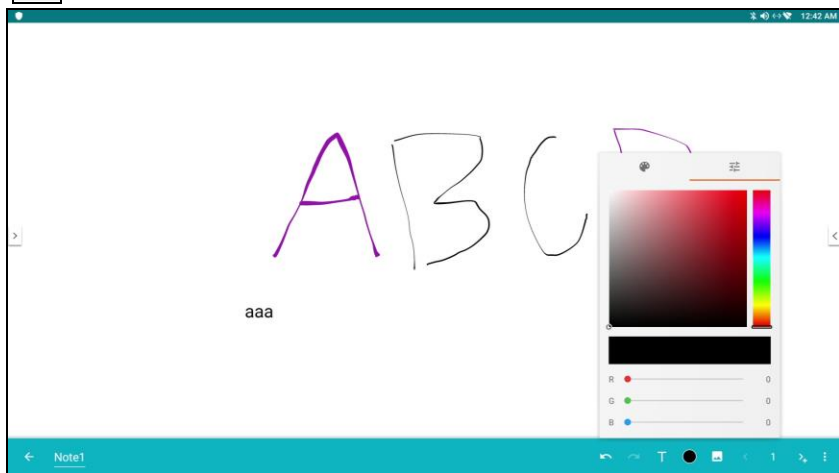

Add image()

To take a picture from connected camera or select an image from local or external USB pen drive.

■ Take picture

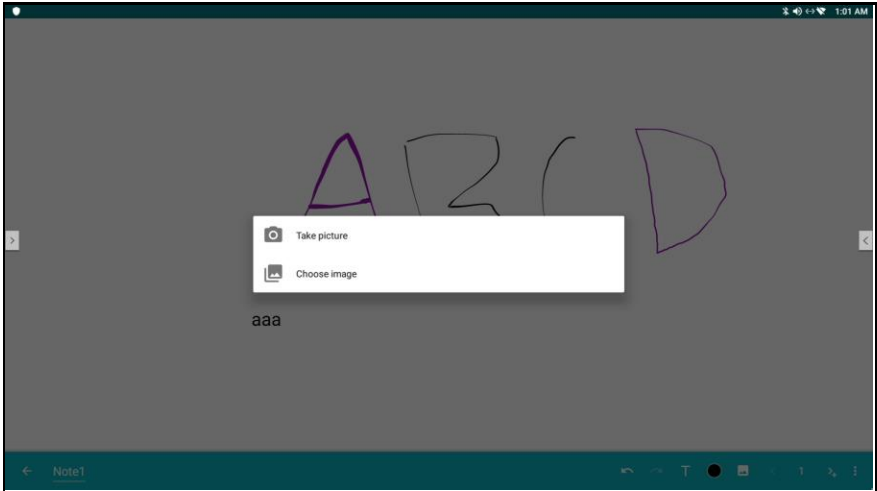

Take pictures from connected camera. Please make sure the camera is well connected and power on.

Select  and select "Take picture".

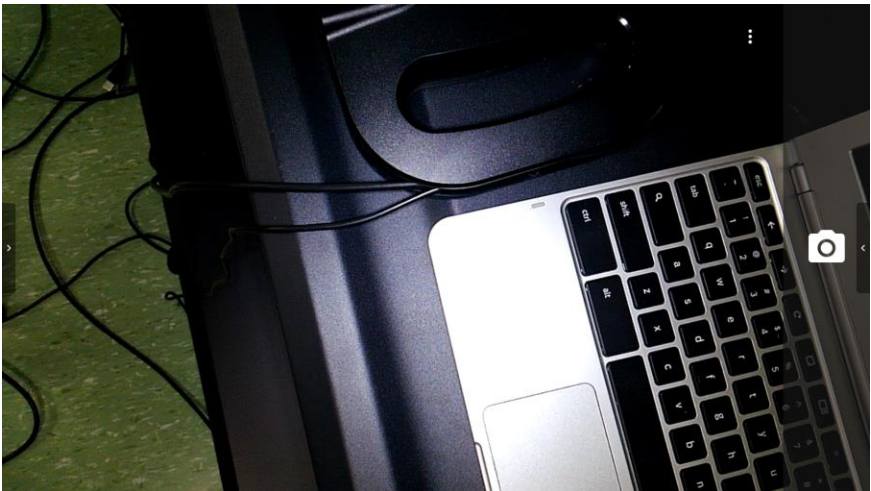

1. Select  to take picture.





2. Select  to accept the picture. To re-take, select . To discard the taken picture, select .



Select  can adjust the flash, display grid, and time if camera support those function.

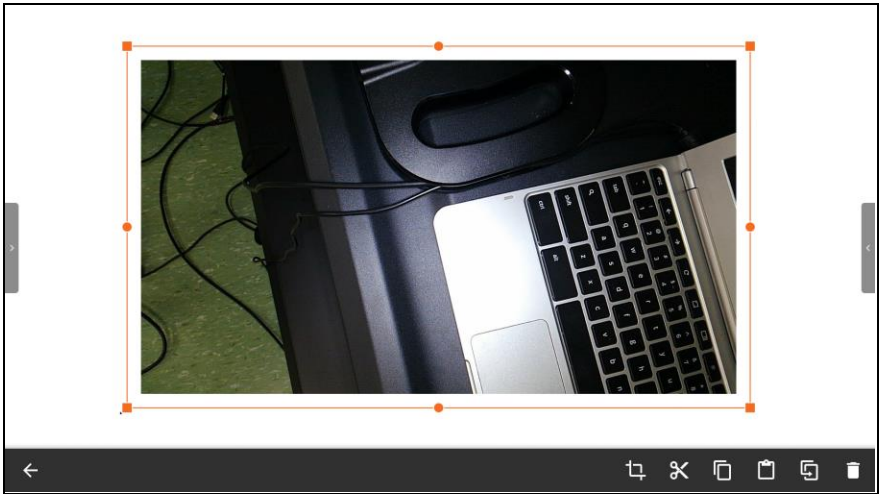



3. After accepting the picture, the screen will switch to edit mode. Touch the picture can move picture around. Select  can back to whiteboard screen.





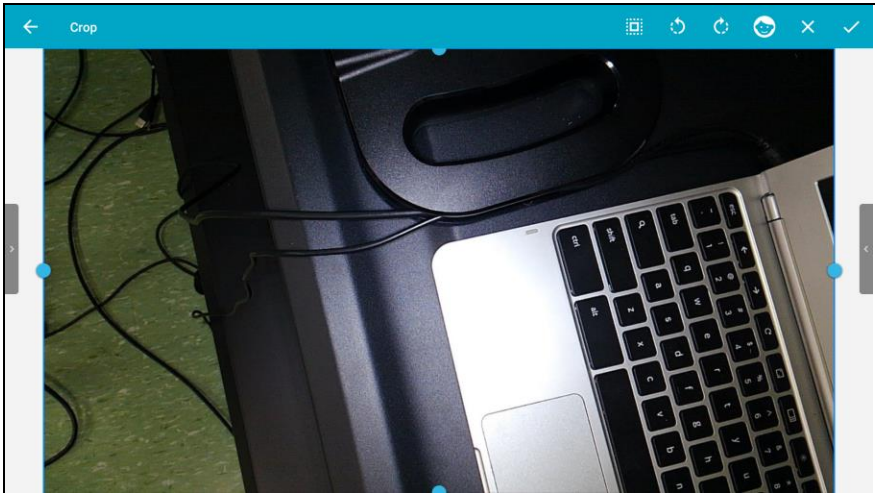

-  : To crop the image. In Crop mode, user can do following action:

- | | | | |
|---|--------------|---|-------------|
|  | Select all |  | Detect face |
|  | Rotate left |  | Cancel |
|  | Rotate right |  | Save |

Select  or  can go back to edit mode.





-  : Cut the picture. The cut image can be pasted. Select  to paste.

-  : Make a copy of picture. Select  can paste the picture.

-  : Paste the cut or copy of the picture.

-  : Duplicate the picture. The duplicate picture will paste on the screen immediately.

-  : Delete the selected part.

4. In edit mode, select  can switch to whiteboard screen.

■ Choose image

Select an image from local hard disk or external USB pen drive.

Select  and select “Choose image”.

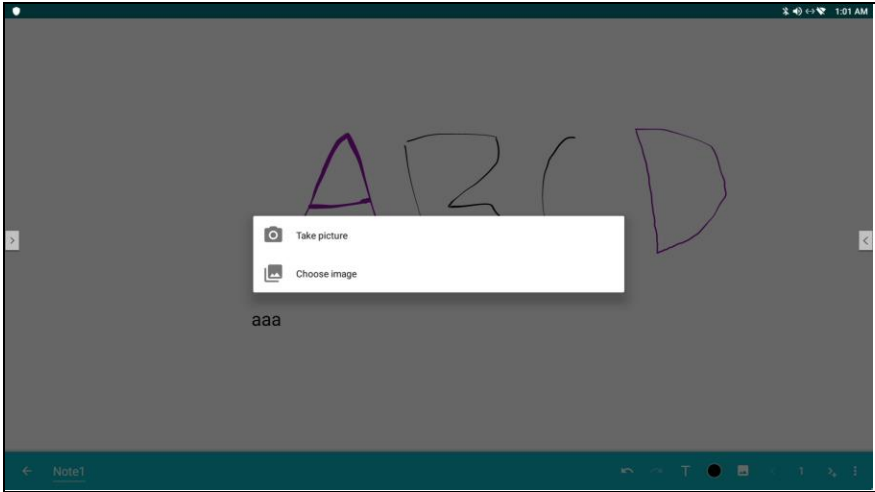



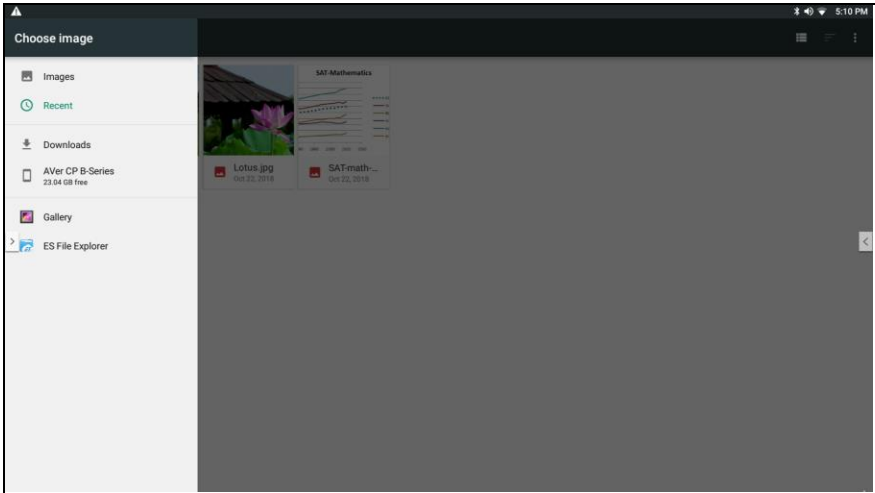

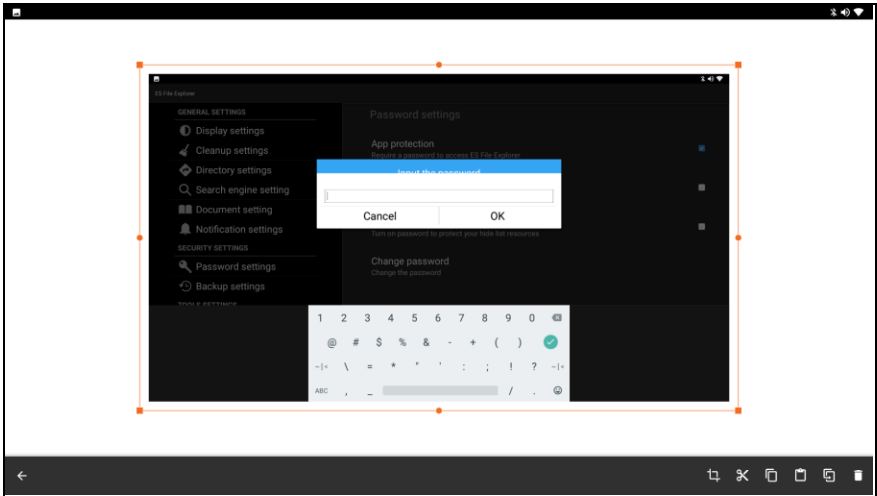

1. Select the image from local or external USB pen drive.







2. The image can be edited.





-  : To crop the image. In Crop mode, user can do following action:

- | | | | |
|---|--------------|---|-------------|
|  | Select all |  | Detect face |
|  | Rotate left |  | Cancel |
|  | Rotate right |  | Save |

Select  or  can go back to edit mode.

-  : Cut the picture. The cut image can be pasted. Select  to paste.

-  : Make a copy of picture. Select  can paste the picture.

-  : Paste the cut or copy of the picture.

-  : Duplicate the picture. The duplicate picture will paste on the screen immediately.

-  : Delete the selected part.

3. In edit mode, select  can switch to whiteboard screen.

Sub-menu()

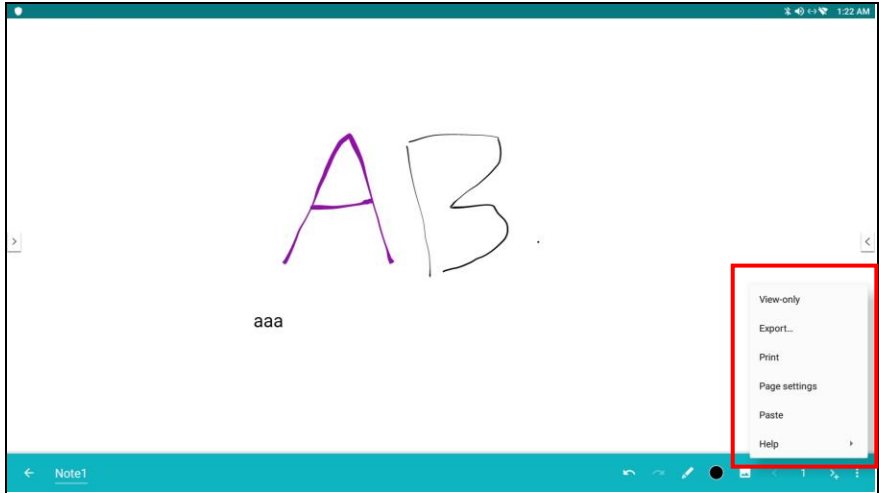

- **View Only:** Change to view only mode. No action can be operated. Select  can back to normal mode.

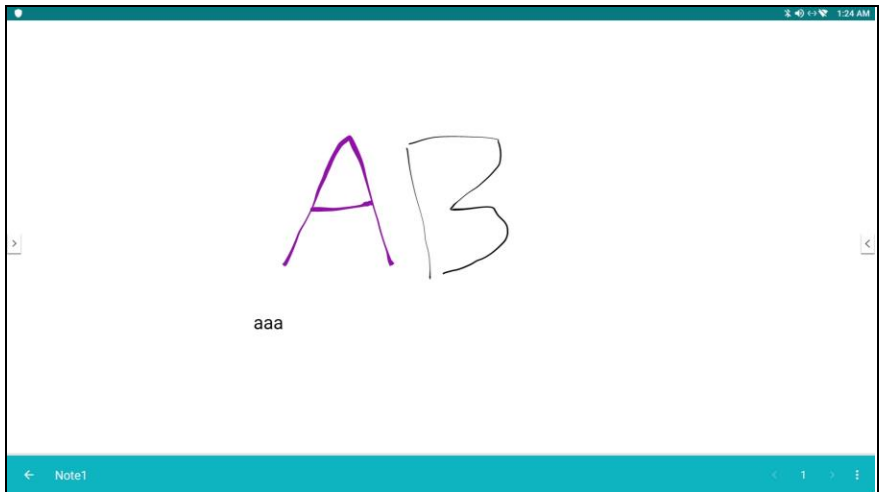

- **Export:** Export the note page or all note pages to PDF, PNG, JPEG file and share to specific path.

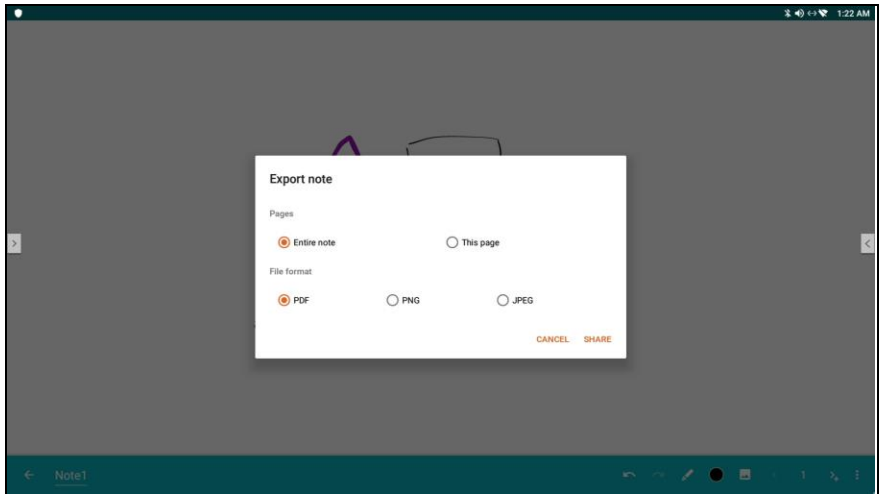

Select **"SHARE"** and select the type to share.

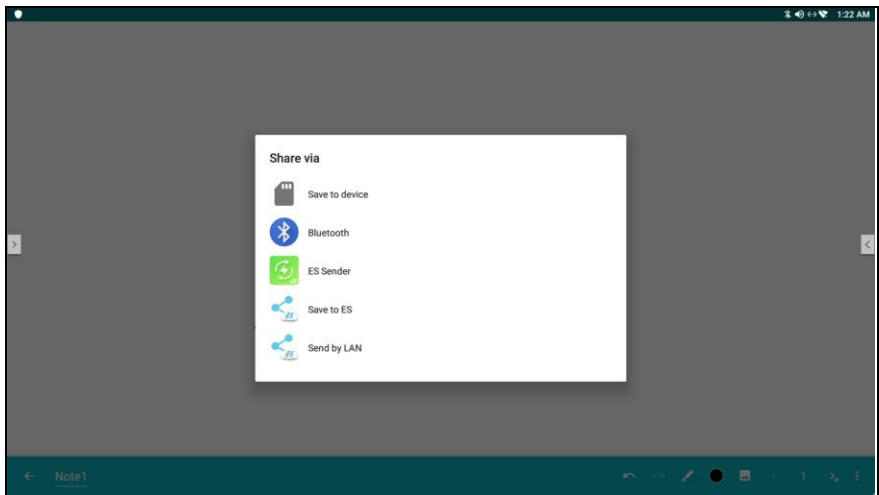

- **Print:** To print out the note page.
- **Page Setting:** Change background (note format), note page size, and color of note page.

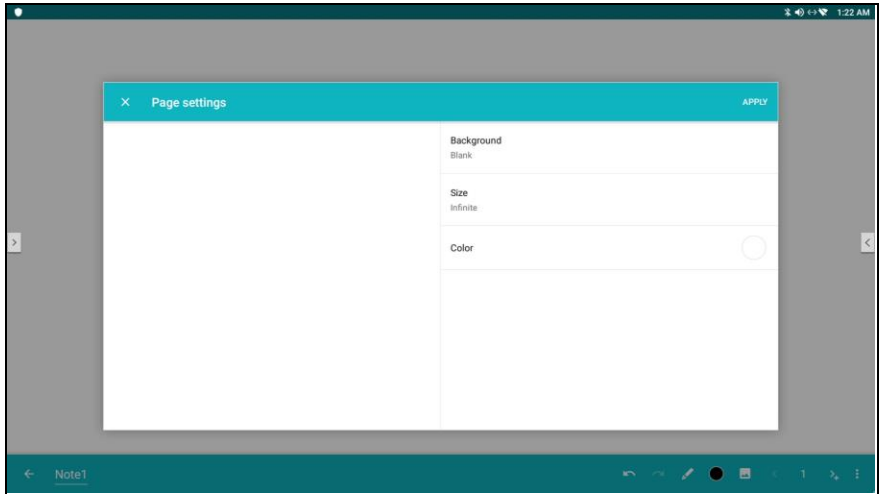

- **Paste:** In edit mode, user does the cut, copy, or duplicate and select “Paste” from sub-menu list can be pasted the object on note page.
- **Help:** View the tutorial and FAQ.

Screen Share

Devices are able to interact directly with the collaboration box across all platforms (Windows, iOS, Android, Mac) and share content wirelessly without any app or add-on hardware installation.

Enable Screen Share

1. Network Setup (Ethernet & WIFI).

[Note]

- a. If you want to share video or do Chromecast, suggest you to use 5G network for casting.
- b. If you want to share via Miracast, please make sure you open the WIFI connection.

2. Open the screen sharing app.

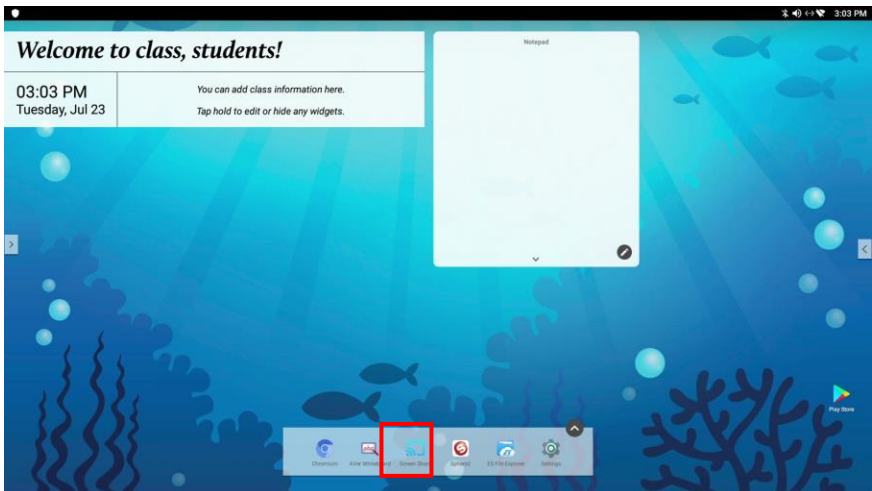

3. Please make sure collaboration box device and your sharing device is in the same network.

[Note] If you want to share via Miracast, you don't need to setup the same network between your devices.

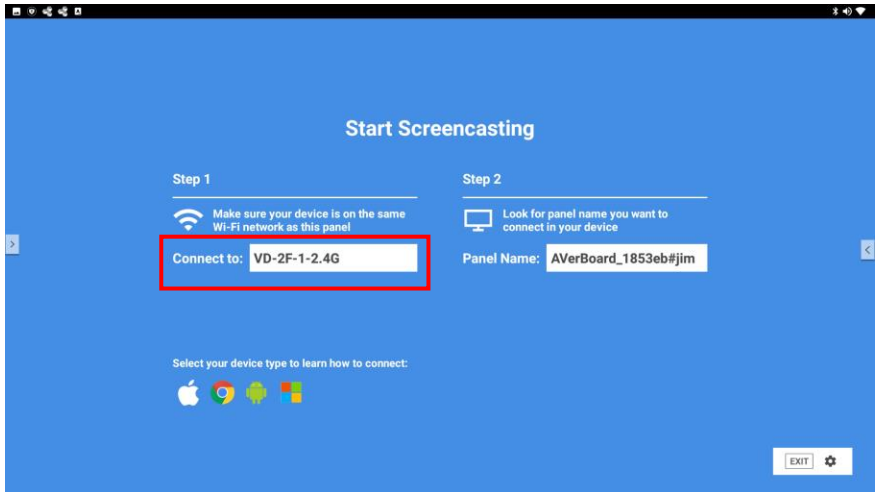

4. Use device's default mirror function to search the collaboration box name.

[Note] Each collaboration box has different Panel Name. You can find it in Screen Share main page.

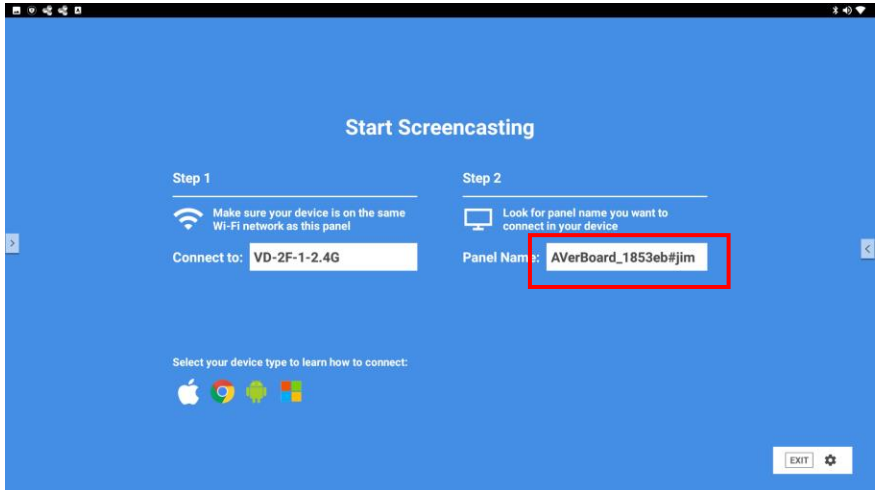

Setup Screen Share

AirPlay Onscreen Code

Enable/disable the AirPlay code to display on screen for Apple device connection.

1. Select **Screen Share** > .

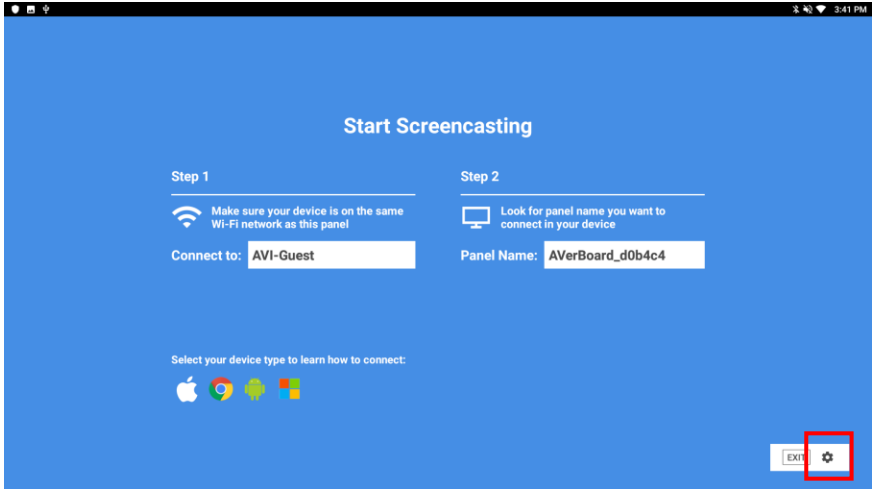

2. Select AirPlay Onscreen code to enable.

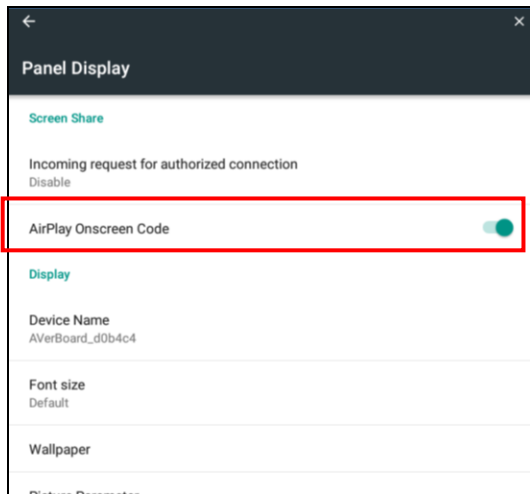

- Then, the AirPlay code is displayed on Screen Share screen. User can click “” to refresh the AirPlay code.

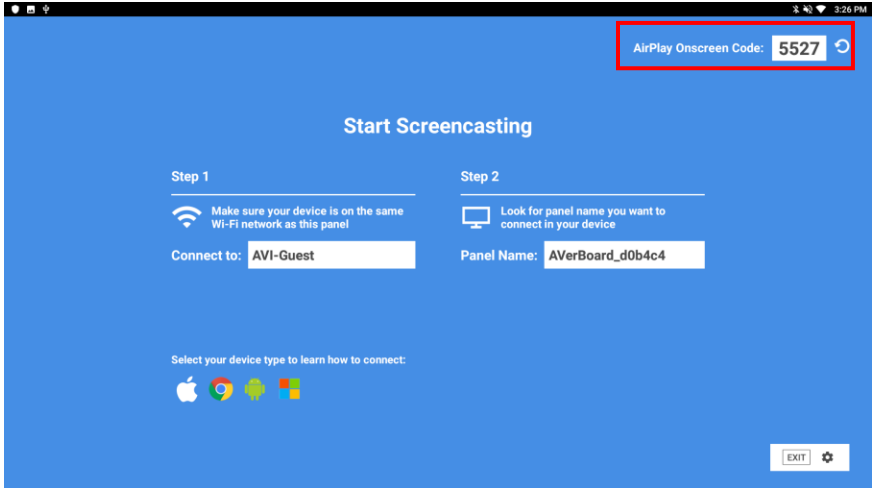

Incoming request for authorized connection

Enable/disable for multiple connection authority.

[Note] For multiple connections, still only one device screen can be displayed on the screen.

- Select **Screen Share** > .

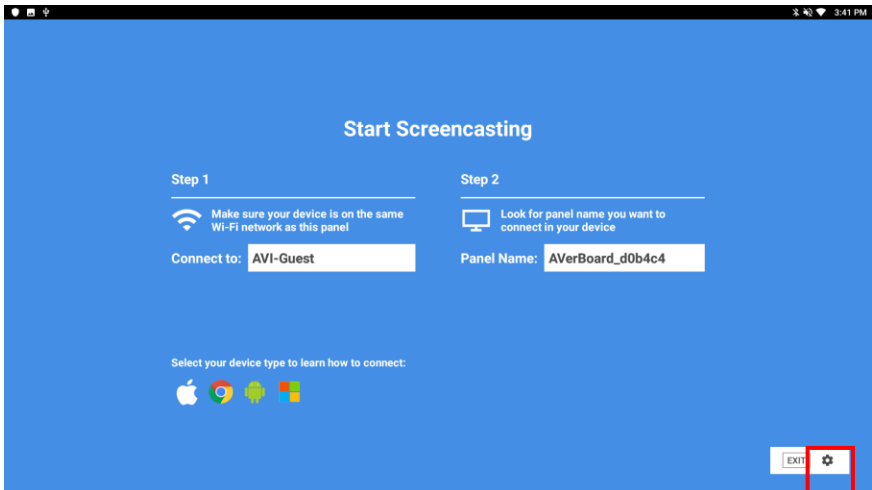

2. Select **Incoming request for authorized connection** > **Enable with 10/20/30 seconds timeout**.
The authorization request will display on screen for 10/20/30 seconds when connection request is coming. The default is **Disable**.

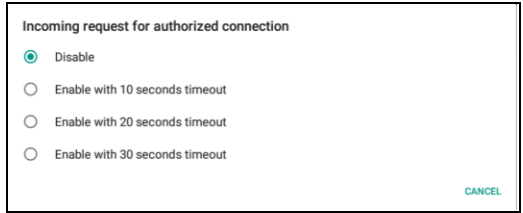
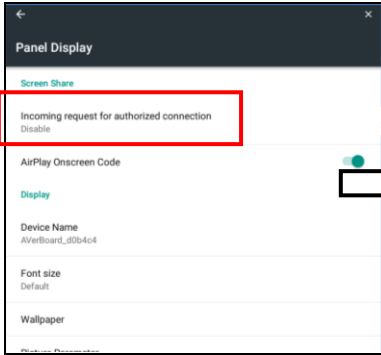

Device Name

Change the collaboration box name that use for connection identity.

1. Select **Screen Share** > 

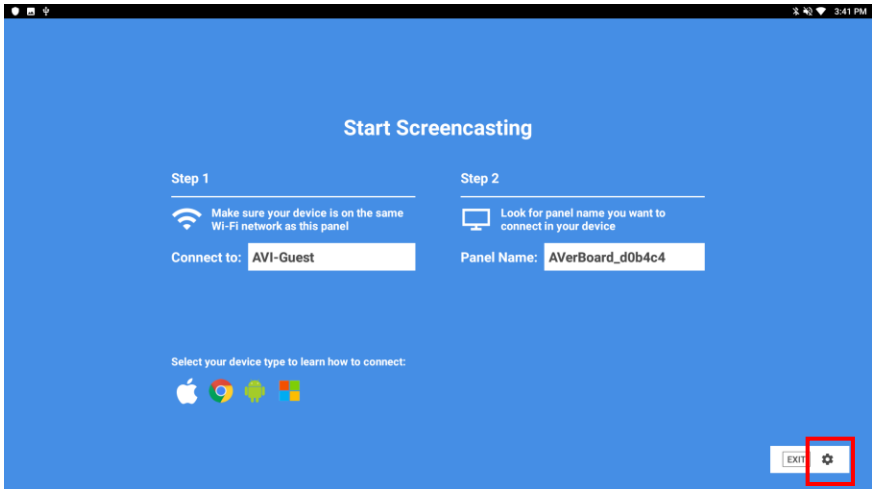

2. Select **Device Name** > Enter the new device name > **OK**.

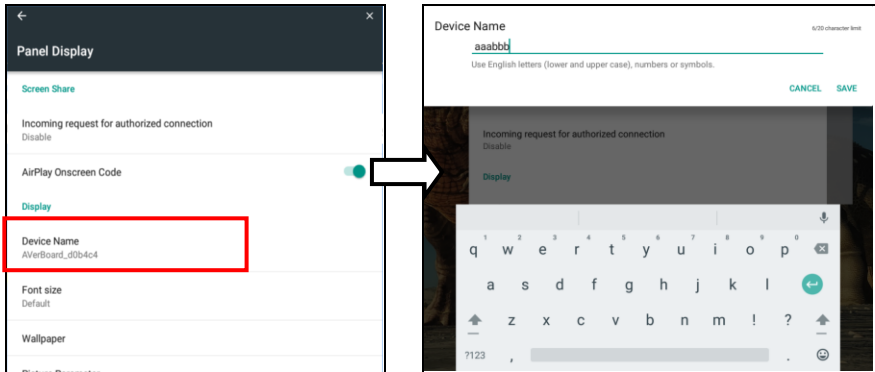

Sharing content from Apple product to the Collaboration Box

What is Airplay?

Airplay is a proprietary protocol developed by Apple Inc. that allows wireless display on Airplay-enabled devices.

How to use AVer ScreenShare app via Airplay?

1. Enable network connection (Ethernet or WIFI)
2. Open the screen sharing app ()
3. If connected via Wi-Fi, please check that the network name displayed on your screen share main page is the same as the network your device is connected to.
4. Use built-in screen mirroring function in your device to search Panel Name.

[Note] Each collaboration box has different Panel Name. You can find it in Screen Share main page.

To share your iOS device's screen (i.e. iPhone or iPad) to the panel

1. Swipe up from the bottom of your screen to open Control Center.

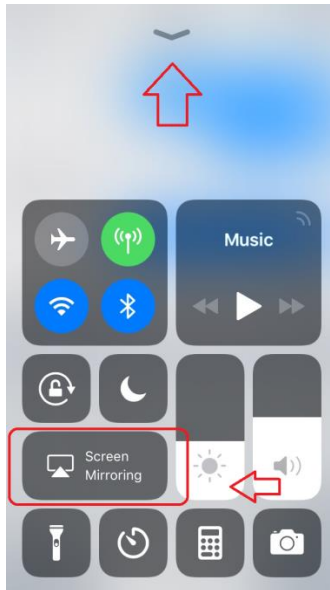

- In Control Center, tap **Screen Mirroring**, then select your **Panel Name** from the list.

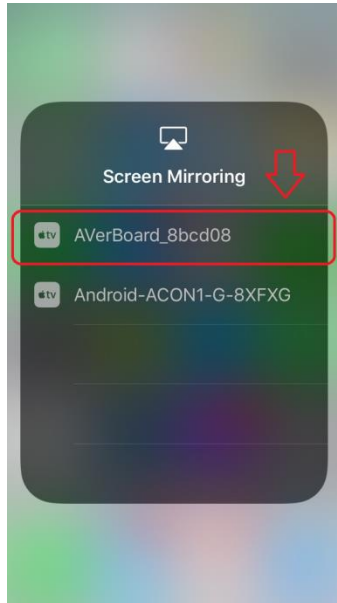

- Don't see your panel name? Try connecting your iOS device to the same Wi-Fi network as the panel you want to Airplay to.
- To turn off Airplay Mirroring, swipe up from the bottom of your screen to open Control Center. In Control Center, tap your panel name and stop mirroring.



To share your Mac computer's desktop to the panel

1. Click on the Airplay icon on the right side of your Mac's menu bar. , then select your collaboration box name from the list.

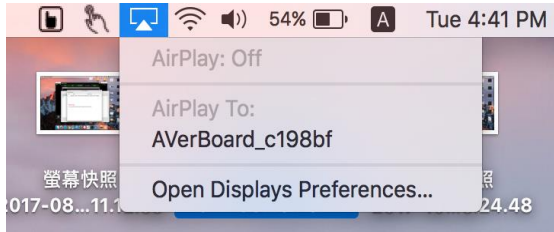

2. To turn off Airplay Mirroring, click on Airplay icon on the right side of your Mac's menu bar, click on Turn Airplay: Off or Airplay: Off.



3. If you don't see your panel name in the Airplay menu, please check your firewall settings :
 - a. Choose Apple menu -> System Preferences, then click Security & Privacy.
 - b. Click the lock icon, and then enter an administrator name and password.
 - c. From the Fire wall tab, click Fire wall Options.
 - d. Make sure that "Block all incoming connections" is not selected, and "Automatically allow signed software to receive incoming connections" is selected.

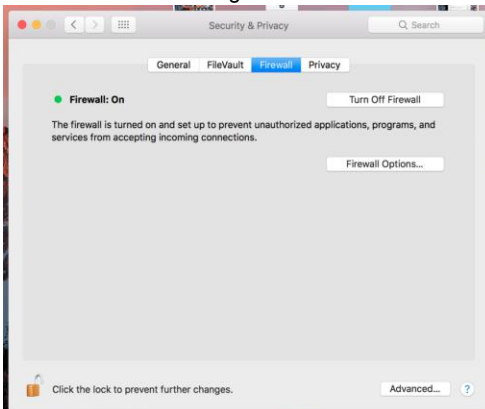

Troubleshooting

Issue	Solution
Optimal performance	<ul style="list-style-type: none"> • Make sure your collaboration box and Airplay device are connected to the same wireless network name (SSID) • Make sure your collaboration box and Airplay device are connected to a Wi-Fi network with AP isolation disabled. • AP isolation: Your Wi-Fi network configuration could prevent devices from communicating with Airplay. In order to resolve this issue, you will need to disable AP (access point) isolation, also known as client isolation, on your router. Please refer to your router documentation to learn how to disable AP isolation. • If you do not have access to your router settings, or if you are attempting to connect through a guest, hotel or public network with AP/client isolation, you will be unable to setup your Airplay.
Your panel name does not appear in the list of available devices.	<ul style="list-style-type: none"> • Make sure your computer is on the same network as the collaboration box. • If your collaboration box is using a wired network connection, try connecting it to a wireless network. <p>[Note] Wired and wireless networks don't often share the same network subnet. Connecting the panel to a wireless network might help the connection between the panel and a mobile device or computer that's connected wirelessly. Refer to Screen Share Network Requirements document for more details. http://averusa.com/classroom-technology/downloads/AVer-IFP-Screen-Share-Network-Requirements.pdf</p>
The video and audio are out of sync.	<ul style="list-style-type: none"> • If your network is slow or congested, Screen Share is affected. Contact your administrator to check network bandwidth. • Not all devices are designed for video encoding for Screen Sharing, so video streaming might not behave as expected. • Sharing videos or playing video games with frequent screen updates requires more network bandwidth. Try reducing the video quality to improve performance.
Stuttering or poor quality	<ul style="list-style-type: none"> • Your collaboration box and device should be within ~15 feet (4 meters) of each other. • Make sure both your collaboration box and device are connected to the same Wi-Fi network channel, either 2.4GHz or 5GHz.

Supported Apple devices and operating systems

1. Operation systems
 - iOS 10 or later
 - OS X 10.11 (El Capitan) or later
2. Apple devices
 - iPhone 4S or later
 - iPad Air or later
 - MacBook 12-inch or later
 - MacBook Pro 13-inch or later

Sharing content from Chrome solution to the collaboration box

What is Chromecast?

Chromecast is Google cast, it is a proprietary protocol developed by Google that allow s wireless display on Chromecast-enabled devices.

How to use AVer ScreenShare app?

1. Enable network connection (Ethernet or WIFI)
2. Open the screen sharing app ().
3. If connected via Wi-Fi, please check that the network name displayed on your screen share main page is the same as the network your device is connected to.
4. Use built-in screen mirroring function in your device to search Panel Name.

[Note] Each collaboration box has different Panel Name. You can find it in Screen Share main page.

5. You can use the Chrome browser and Google Cast (a browser extension for Chrome) to share the desktop or a specific browser tab from your computer.
6. There are two ways to share your content via Chromecast:
 - Use Chrome browser
 - Use built-in screen casting on your Chromebook

To download Chrome browser for your device

1. On your computer, go to [google.com/chrome](https://www.google.com/chrome).
2. Click **Download** > for personal computers > Download latest Chrome browser.
3. Follow the on-screen instructions.

To share content from the Chrome browser to the panel

1. In Chrome browser setting menu, click **Casting**, then select **Panel Name** from the list that you can connect the panel with desktop mode.
2. You can select tab or desktop mode.

To share content from the Chrome book to the panel

1. In menu, click **Cast devices available**, and then select your **Panel Name** from the list.

[Note] Cast to Desktop is recommended to share your screen.

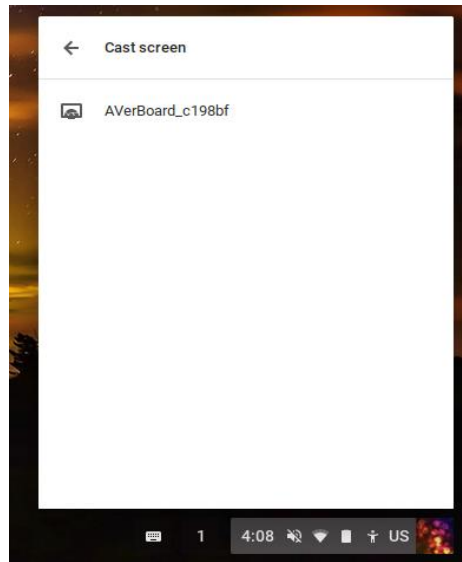
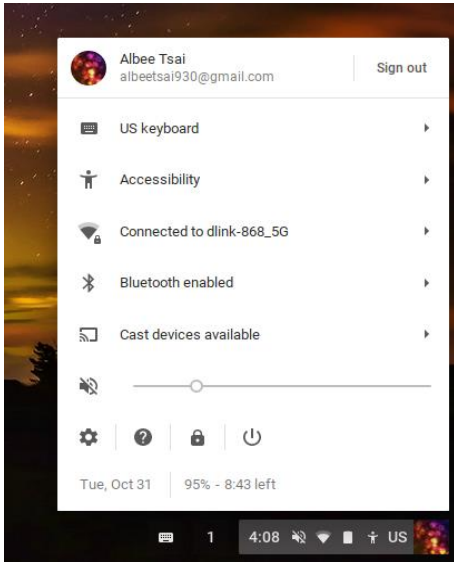

2. In menu, click Stop for disconnecting.

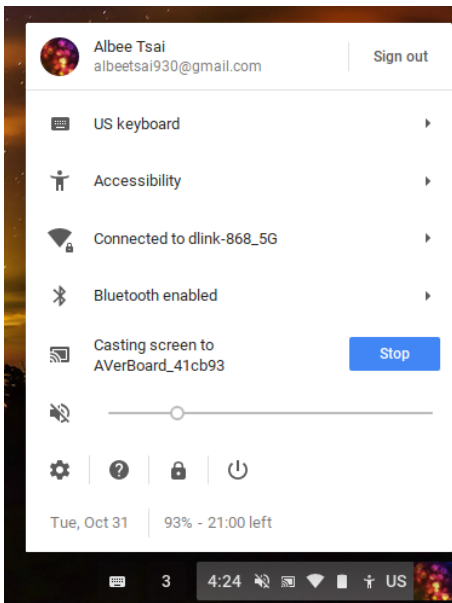

Troubleshooting

Issue	Solution
Optimal performance	<ul style="list-style-type: none"> • Make sure your panel and Chrome device are connected to the same wireless network name (SSID) • Make sure your panel and Chrome device are connected to a Wi-Fi network with AP isolation disabled. • AP isolation: Your Wi-Fi network configuration could prevent devices from communicating with Chromecast. In order to resolve this issue, you will need to disable AP (access point) isolation, also known as client isolation, on your router. Please refer to your router documentation to learn how to disable AP isolation. • If you do not have access to your router settings, or if you are attempting to connect through a guest, hotel or public network with AP/client isolation, you will be unable to setup your Chromecast.
Your panel name does not appear in the list of available devices.	<ul style="list-style-type: none"> • Make sure your computer is on the same network as the panel. • If your panel is using a wired network connection, try connecting it to a wireless network. <p>[Note] Wired and wireless networks don't often share the same network subnet. Connecting the panel to a wireless network might help the connection between the panel and a mobile device or computer that's connected wirelessly.</p> <p>Refer to Screen Share Network Requirements document for more details.</p> <p>http://averusa.com/classroom-technology/downloads/AVer-IFP-Screen-Share-Network-Requirements.pdf</p>
The video and audio are out of sync.	<ul style="list-style-type: none"> • If your network is slow or congested, Screen Share is affected. Contact your administrator. • Not all devices are designed for video encoding for Screen Sharing, so video streaming might not behave as expected. • Sharing videos or playing video games with frequent screen updates requires more network bandwidth. Try reducing the video quality to improve performance. • Screen Share has not been optimized for performance with Chromebooks. For best results, limit usage to static content.
Stuttering or poor quality	<ul style="list-style-type: none"> • Your panel and device should be within ~15 feet (4 meters) of each other. • Make sure both your panel and device are connected to the same Wi-Fi network channel, either 2.4GHz or 5GHz.

Supported Chromebook devices and operating systems

1. Operating system
 - Chrome OS 59 or later
2. Chromebook devices
 - Acer Chromebook C11 C740-C4PE
 - Dell Chromebook11 P22T001
 - HP Chromebook 14 -ak010nr
 - HP Chromebook 14 G4

Sharing content from Windows computer to the panel

What is Miracast?

Miracast is a wireless display standard included in Windows 8.1, Windows 10, Android 4.2 and newer versions of these operating systems.

It is the Wi-Fi Direct standard, which allows for point-to-point connection between devices without the use of router.

How to use AVer Screen Share app via Miracast?

1. Open the screen sharing app ()
2. Please make sure your panel and sharing device are in the same network.
3. Use built-in screen mirroring function to search the Panel Name.

[Note] Each collaboration box has different Panel Name. You can find it in Screen Share main page.

4. If your computer is running Windows 10 or Windows 8.1 operating system, you can use the built-in Miracast protocol to share your screen.

For earlier versions of Windows OS, you can use the Chrome browser to share content from your Windows device through the Chromecast protocol. Please see Chrome solution.

[Note] Please ensure that any firewalls on your device are configured to allow for Miracast connections.

To share content from the Windows 8.1/10 OS (Action center)

1. Go to the action center or Tap Windows key + A that you can connect the panel with desktop mode
2. Click "Project" button then select an option:
 - ✓ **PC screen only:** No content is shared to the panel.
 - ✓ **Duplicate:** The same content appears on both screens.
 - ✓ **Extend:** The computer's desktop is extended across the computer and panel's screen. You can move items between the two screens.
 - ✓ **Second screen only:** Content is shared to the panel. The computer's screen is blank.
3. Click "**Connect to a wireless display**" and Windows will start search the Miracast devices around you.
4. Click "**disconnect**" to stop the device and panel's sharing.

To share content from the Windows 8.1/10 OS(Windows settings)

1. Go to Windows settings and click devices to add Bluetooth or other device that you can connect the panel with desktop mode.

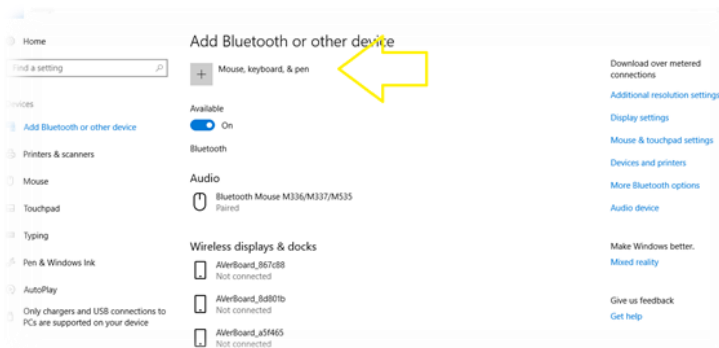
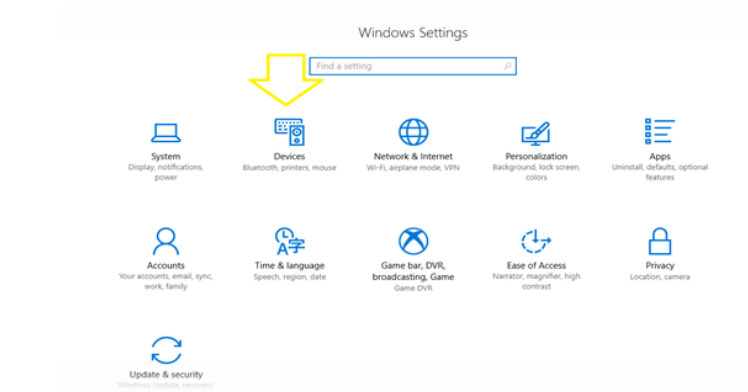

2. Click Wireless display or dock and Windows will start search the Miracast devices around you.

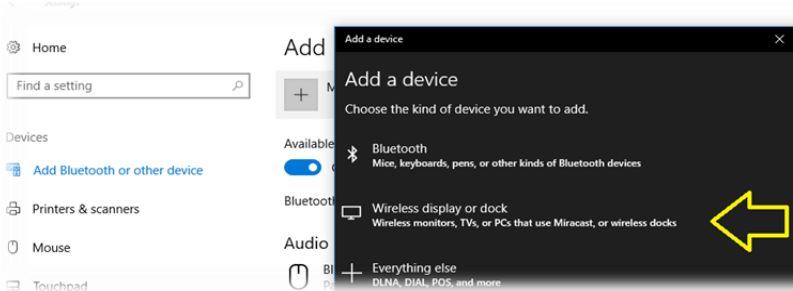

3. Click "disconnect" to stop the device and panel's sharing.

Troubleshooting

Issue	Solution
My Windows OS is not 8.1 or 10 and I have no built-in Miracast on my Windows device.	<ul style="list-style-type: none"> • Alternative solution is to download and install Chrome browser onto your Windows device. • Download the Chrome browser from google.com/chrome and install on your device. • Navigate to the Chrome Settings menu in the Chrome toolbar in the upper right corner of your browser -> click "Cast..." • Click Cast desktop. • Choose the panel name you want to cast to.
Optimal performance	<ul style="list-style-type: none"> • Make sure your panel and Windows device are connected to the same wireless network name (SSID) • Make sure your panel and Windows device are connected to a Wi-Fi network with AP isolation disabled. • AP isolation: Your Wi-Fi network configuration could prevent devices from communicating with Miracast. In order to resolve this issue, you will need to disable AP (access point) isolation, also known as client isolation, on your router. Please refer to your router documentation to learn how to disable AP isolation. • If you do not have access to your router settings, or if you are attempting to connect through a guest, hotel or public network with AP/client isolation, you will be unable to setup your Miracast.
Your panel name doesn't appear in the list of available devices.	<ul style="list-style-type: none"> • Make sure your computer is on the same network as the panel. • If your panel is using a wired network connection, try connecting it to a wireless network. <p>[Note] Wired and wireless networks don't often share the same network subnet. Connecting the panel to a wireless network might help the connection between the panel and a mobile device or computer that's connected wirelessly.</p> <p>Refer to Screen Share Network Requirements documentation for details. http://averusa.com/classroom-technology/downloads/AVer-IFP-Screen-Share-Network-Requirements.pdf</p>
When using Miracast, you can't add or connect to the panel.	<ul style="list-style-type: none"> • If you can't add the panel, wait for it to become ready and then try again. If that doesn't work, try restarting your computer and display. • If your Windows computer won't connect to the panel, try removing and then restart app to reconnect again.

Issue	Solution
The video and audio are out of sync.	<ul style="list-style-type: none"> • If your network is slow or congested, Screen Share is affected. Contact your administrator. • Not all devices are designed for video encoding for Screen Sharing, so video streaming might not behave as expected. • Sharing videos or playing video games with frequent screen updates requires more network bandwidth. Try reducing the video quality to improve performance. • Screen Share has not been optimized for performance with Windows device. For best results, limit usage to static content.
Stuttering or poor quality	<ul style="list-style-type: none"> • Your panel and device should be within ~15 feet (4 meters) of each other. • Make sure both your panel and device are connected to the same Wi-Fi network channel, either 2.4GHz or 5GHz.

Supported Miracast devices and operating systems

1. Operating system.
 - Windows OS 8 / 10
2. Miracast devices.
 - Dell Inspiron 14 5000
 - HP ProBook 430G2
 - ASUS-PU401LAC
 - Microsoft-SurfacePro 3
 - Microsoft-SurfacePro 4
 - Acer Aspire Z3-615 (AIO)
 - HP Probook 440
 - Dell-Inspiron 3459
 - MSI GS63VR

Sharing content from Android device to the panel

What is Miracast?

Miracast is a wireless display standard included in Windows 8.1, Windows 10, Android 4.2 and newer versions of these operating systems. It is the Wi-Fi Direct standard, which allows for point-to-point connection between devices without the use of router.

How to use AVer Screen Share app via Miracast or Chromecast?

1. Enable network connection (Ethernet or Wi-Fi)
2. Open the screen sharing app (📶).
3. If connected via Wi-Fi, please check that the network name displayed on your screen share main page is the same as the network your device is connected to.
4. Use built-in screen mirroring function to search the Panel Name.

[Note] Each collaboration box has different Panel Name. You can find it in Screen Share main page.

To share your Android device's screen to the panel

1. In settings, tap **PlayTo**, then select Panel name from the list.

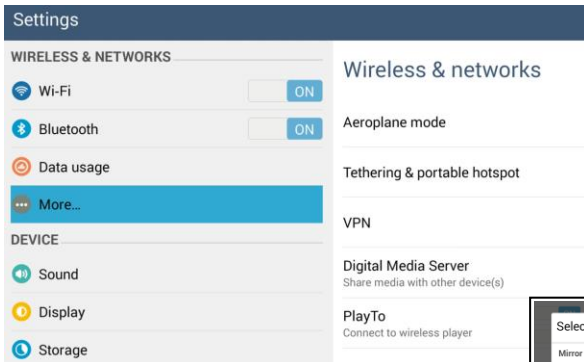

2. Tap **"disconnect"** to stop sharing.

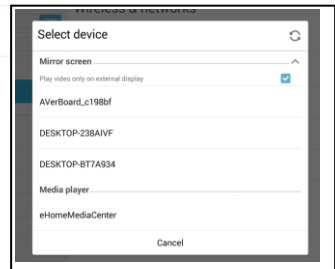

To share your Android device's screen on the panel from the notification shade



1. On your Android device, swipe down to open the notification shade.
2. Look for Screen Mirroring or Smart View or Cast icon, Tap **your selection**.
3. Select your panel name.

If you don't see the board you want, tap **MORE SETTINGS** to show more panels.

4. Tap **"disconnect"** to stop sharing.

Troubleshooting

Issue	Solution
How do I know my device supports Miracast or Chromecast?	<ul style="list-style-type: none">• Android supported Miracast in Android 4.2 (KitKat) and Android 5 (Lollipop).• Google dropped native Miracast support in Android 6 (marshmallow) and later.• If you want to mirror the display from a newer Android phone or tablet, you will need to do so via Chromecast. See Trouble mirroring your Android screen with built-in screen mirroring function? in below section.
Optimal performance	<ul style="list-style-type: none">• Make sure your panel and Android device are connected to the same wireless network name (SSID)• Make sure your panel and Android device are connected to a Wi-Fi network with AP isolation disabled.• AP isolation: Your Wi-Fi network configuration could prevent devices from communicating with Chromecast/Miracast. In order to resolve this issue, you will need to disable AP (access point) isolation, also known as client isolation, on your router. Please refer to your router documentation to learn how to disable AP isolation.• If you do not have access to your router settings, or if you are attempting to connect through a guest, hotel or public network with AP/client isolation, you will be unable to setup your Chromecast/Miracast.
Your panel name does not appear in the list of available devices.	<ul style="list-style-type: none">• Make sure your computer is on the same network as the panel.• If your panel is using a wired network connection, try connecting it to a wireless network. <p>[Note]Wired and wireless networks don't often share the same network subnet. Connecting the panel to a wireless network might help the connection between the panel and a mobile device or computer that's connected wirelessly.</p> <p>Refer to Screen Share Network Requirements document for details. http://averusa.com/classroom-technology/downloads/AVer-IFP-Screen-Share-Network-Requirements.pdf</p>

Issue	Solution
<p>Trouble mirroring your Android screen with built-in screen mirroring function?</p>	<ul style="list-style-type: none"> • All devices running Android 4.4.2 or higher support the Cast Screen feature. However, some Android devices may not have the necessary power to provide an optimized Screen casting experience. • In order to mirror the screen of your Android phone or tablet, you will need a device running Android 4.4.2 and above as well as <u>Chromecast-compatible device</u>. • Alternative solution is to download and install Google Home app on your Android device. • Download the Google Home app  from Google Play Store. • On your Android device, open the Google Home app. • In the top left corner, tap the navigation drawer . • Tap Cast Screen. • Select your Panel Name. <p>[Note] Not all mobile devices have been optimized for screen casting.</p>
<p>The video and audio are out of sync.</p>	<ul style="list-style-type: none"> • If your network is slow or congested, Screen Share is affected. Contact your administrator. • Not all devices are designed for video encoding for Screen Sharing, so video streaming might not behave as expected. • Sharing videos or playing video games with frequent screen updates requires more network bandwidth. Try reducing the video quality to improve performance.
<p>Stuttering or poor quality</p>	<ul style="list-style-type: none"> • Your panel and device should be within ~15 feet (4 meters) of each other. • Make sure both your panel and device are connected to the same Wi-Fi network channel, either 2.4GHz or 5GHz.

Supported Android devices and operating systems

1. Operating systems
 - Android 5.0.2 or later
2. Android devices
 - Asus P022 (Android Pad)
 - HTC Butterfly 2 (Smart Phone)
3. Asus ZE552KL (Smart Phone)

Grouping and Draw Function

The grouping and draw lots function help the user to do group work, competitions and draw lots to do the question answer.

Draw Lots

1. Click  to expand app list and select “**Grouping & Draw**”.

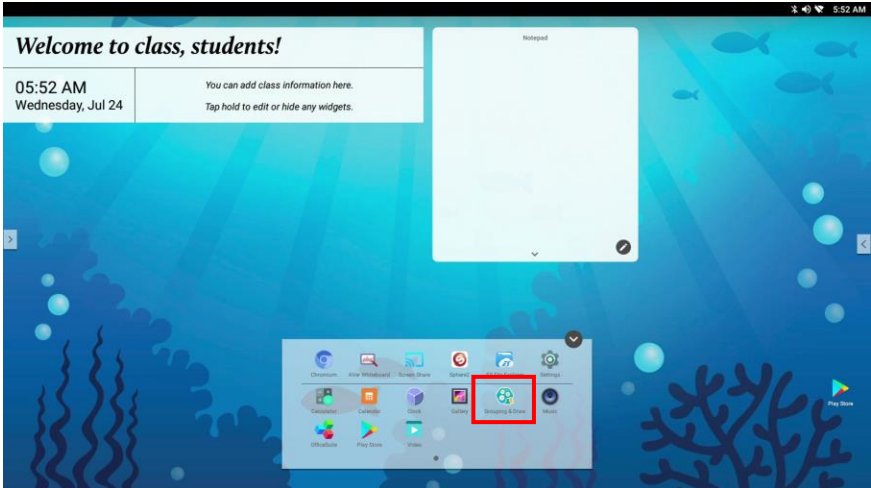

2. Tap “**Draw Lots**”.
3. Enter the **Range** (1~100), ex: 20~90.

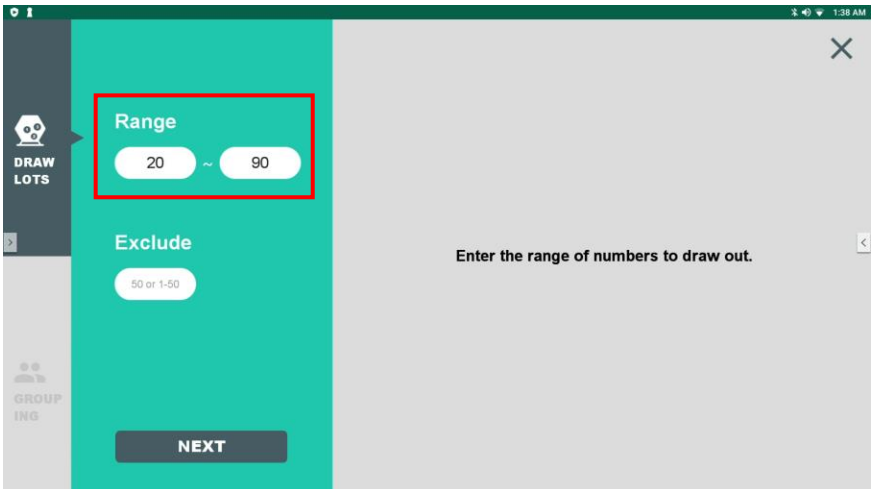

4. Next, enter the number that wants to exclude. If there is no number wanted to exclude, just leave it. Tap “X” can remove the number from exclude list.

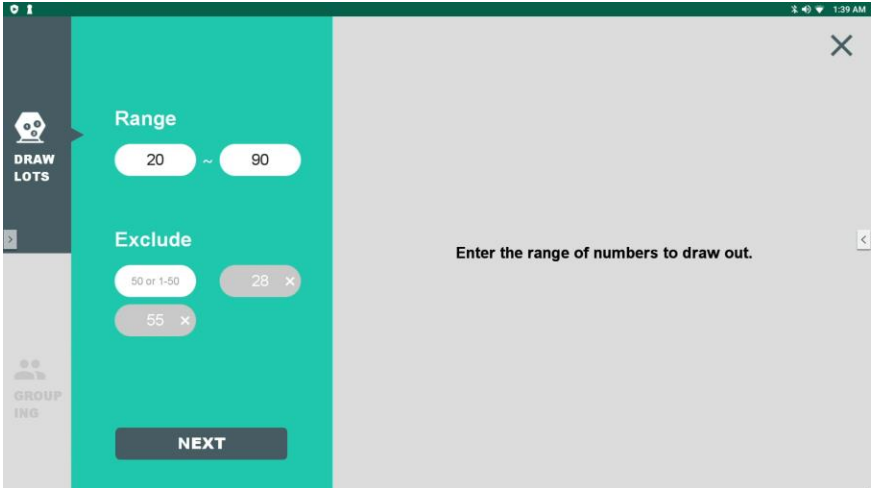

5. Tap “Next” to set the how many people are drawn. Tap “+” to add up the number and “-” to decrease the number of people.

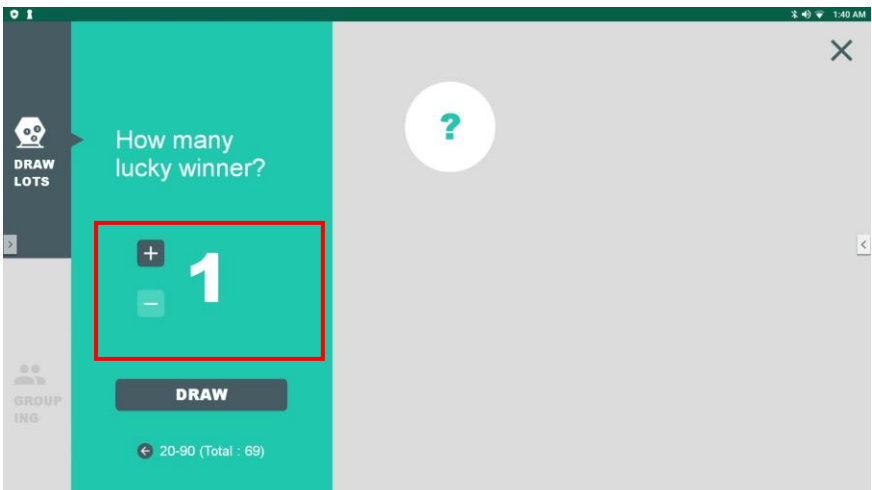

6. Tap **"DRAW"** to draw. The result will display. Tap **"RE-DRAW"** can draw again.

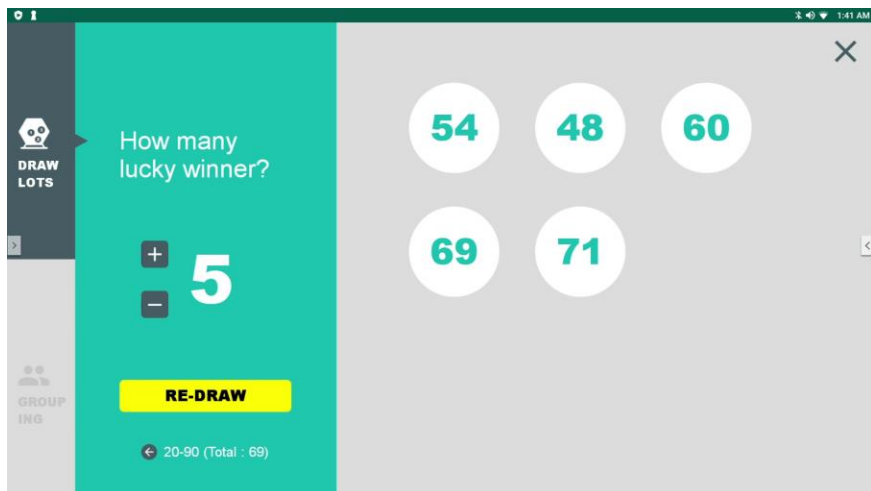

Grouping

1. Click  to expand app list and select “**Grouping & Draw**”.

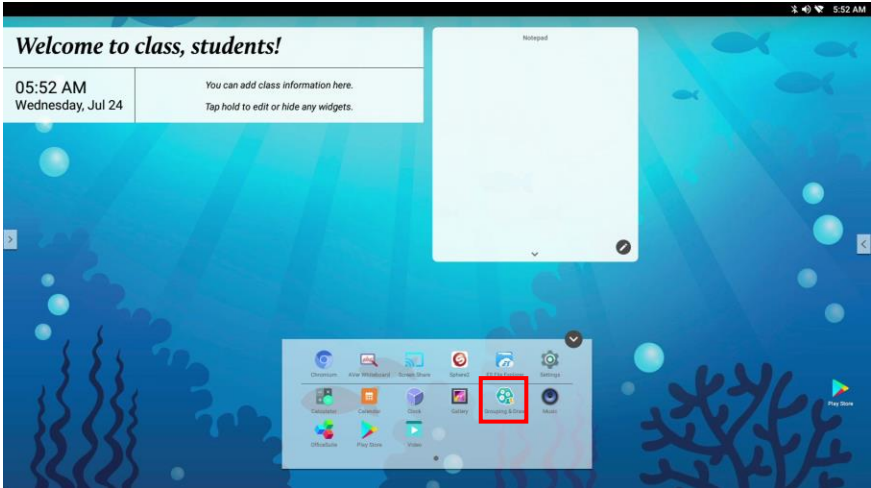

2. Tap “**Grouping**”.
3. Enter the **Range** (1~100), ex: 1~60.

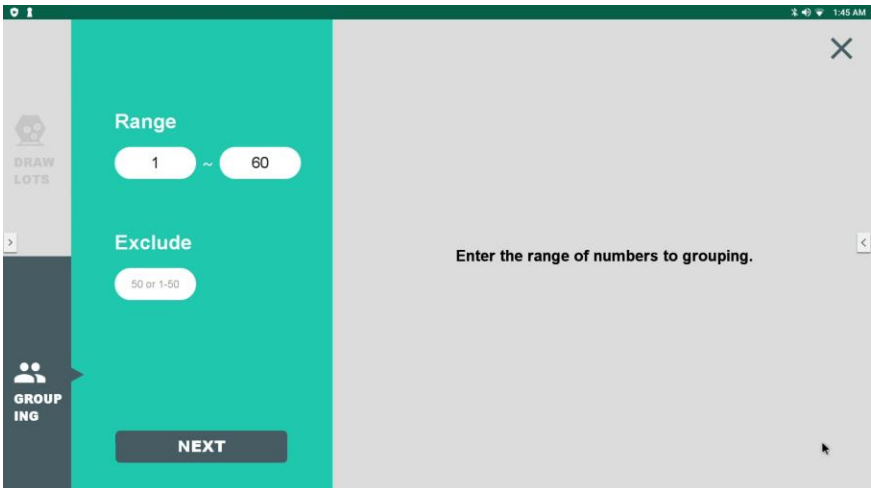

4. Next, enter the number wants to exclude. If there is no number wanted to exclude, just leave it. Tap “X” can remove the number from exclude list.

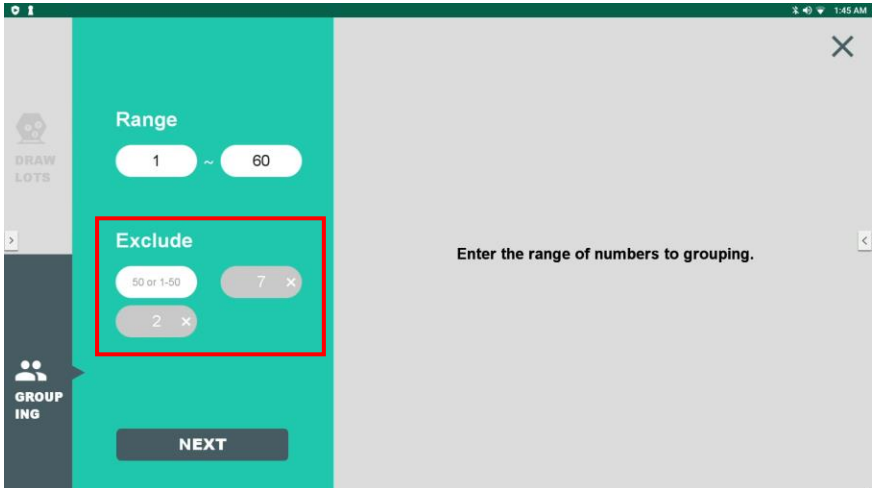

5. Tap “Next” to set the how many groups to divide. Tap “+” to add up the number and “-” to decrease the number of group. Two groups are at least.

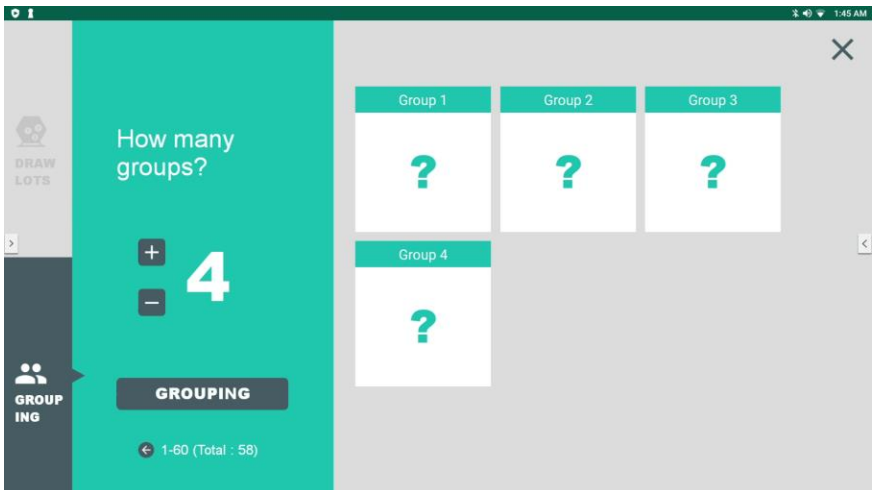

6. Tap **“GROUPING”** to grouping. The result will display it. Tap **“REGROUP”** can grouping again. The number in color means group leader and the group leader can be re-assigned; just tap the number you want.

How many groups?

4

REGROUP

1-60 (Total : 58)

Select number to change the team leader.

Group 1	Group 2	Group 3
27 23	03 30	45 21
49 12	39 36	60 50
33 53	08 13	05 51
29 17	47 20	43 24
38 54	14 34	25 59
01 32	37 19	10 52
15 31	35 44	58 46
42	28	

GROUPING

Gallery

In gallery, use screenshots, pictures, and share screenshots/pictures to specific location. Select **"Gallery"** from app lists at main screen.

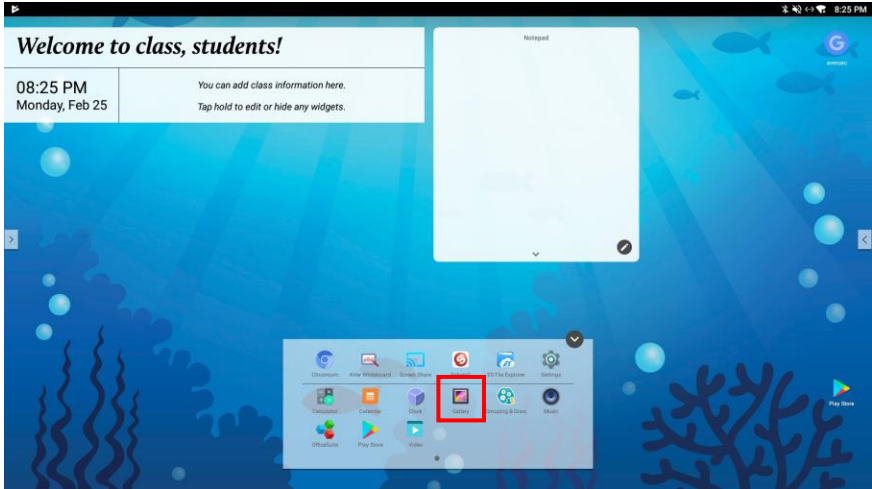

View images

To view the images, select the image or select the folder and select the image to view.

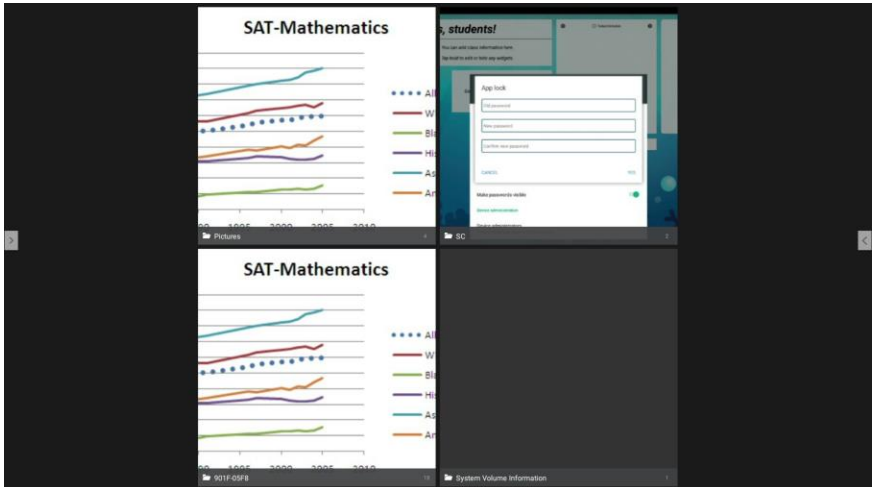

Using Browser

User can operate the browser same as on PC.

Select the “Chromium” to launch the browser app.

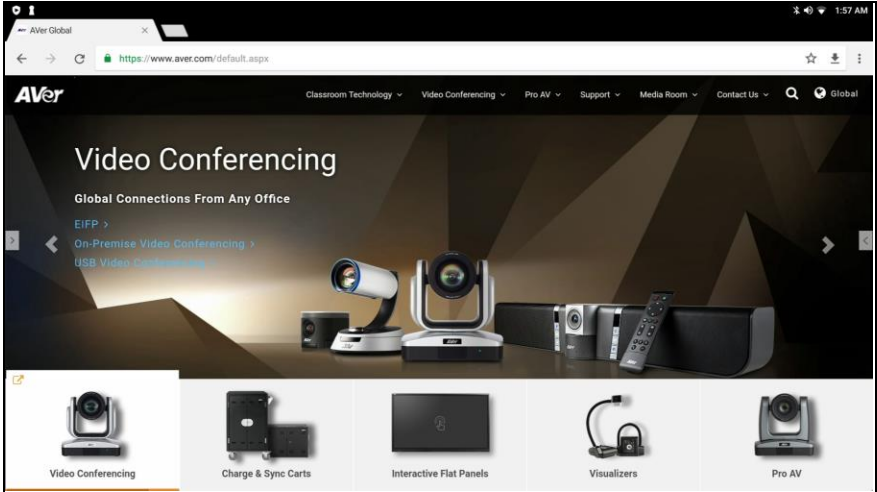

Connect to DoCam

The AVer CB-310 system can connect to DocCam device through the Sphere2 to use the class interactive function in Sphere2.

1. Select **Sphere2** from app list at main screen.
2. Please make sure the DocCam and the AVer CB-310 system are at same local network. The Sphere2 will auto search the available DocCam on your local network and list on screen.
3. Select the DocCam device that wants to connect.
4. Enter the "**Password**" of DocCam and select **OK** to confirm.
5. And, select "**Start**" to connect.

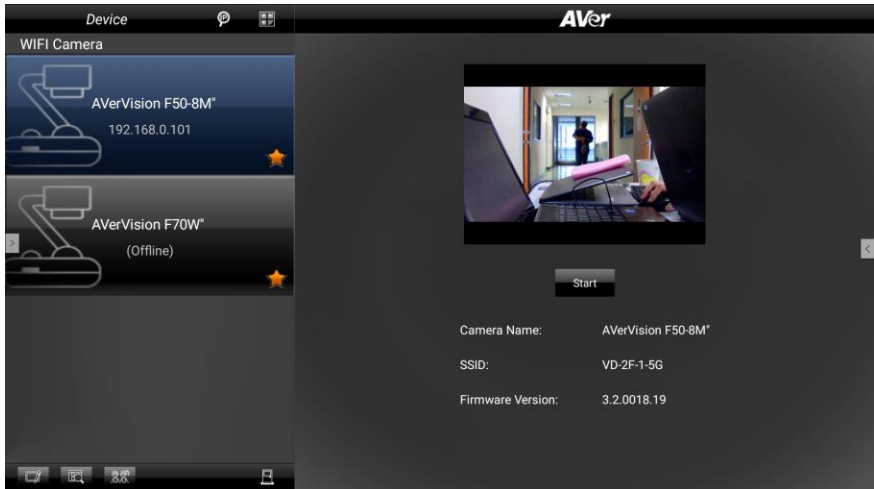

6. How to use Sphere2 application; please refer to user manual of Sphere2.

Internet Connection

There are two ways to access the internet – Ethernet and WiFi connection.

Ethernet Connection

Using Ethernet cable connects AVer CB-310 to your local network.

[Note] Turn off the WiFi function if WiFi connection has connected.

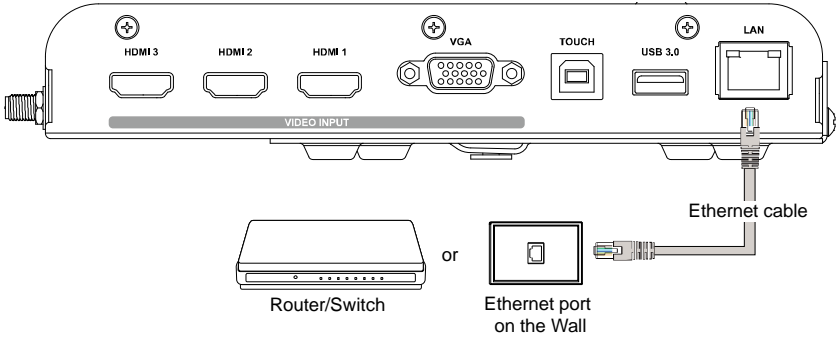

Select **Settings > More > Ethernet**.

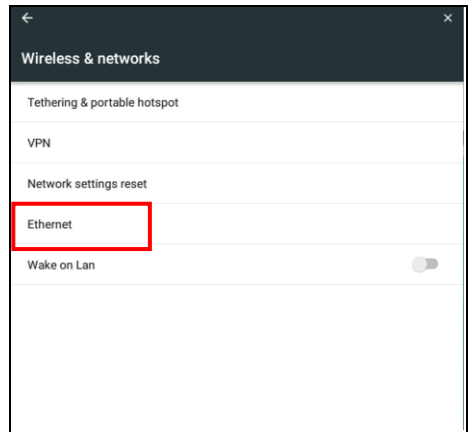
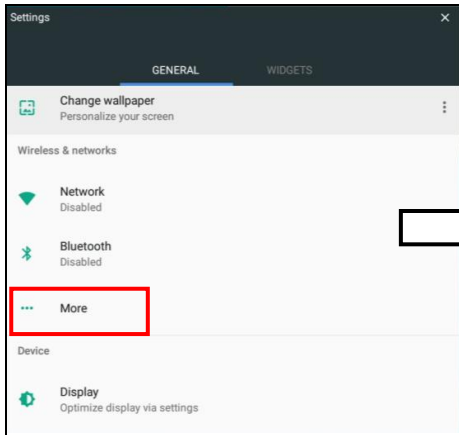

Wi-Fi Connection

Connect AVer CB-310 to internet through the W-iFi AP.

1. Select the “**Settings**” icon to bring out the Settings page.

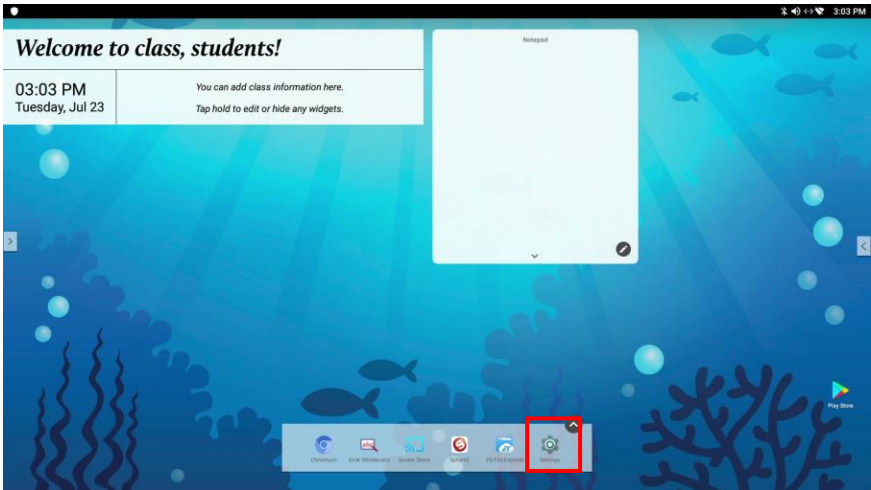

2. In Settings page, select “**Network**”.

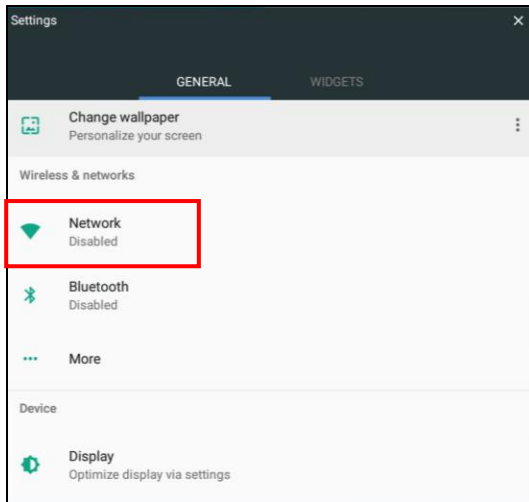

3. Set Wi-Fi to “On”.

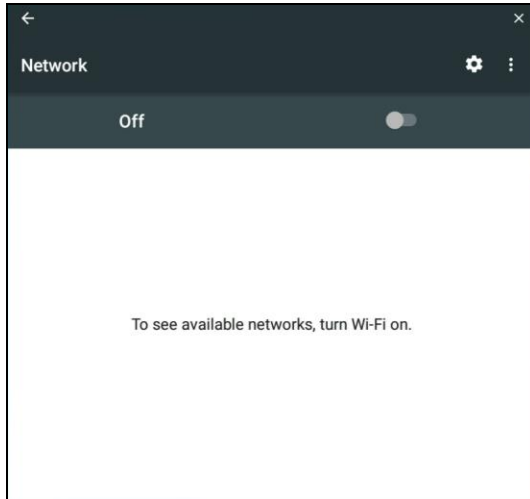

4. Select available Wi-Fi networks to connect.

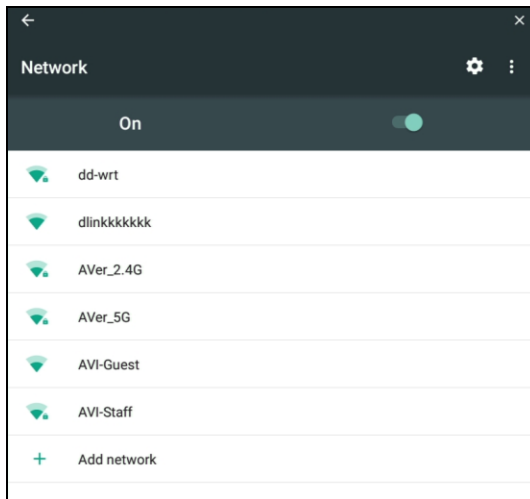

Adjust Date and Time

1. Select the “**Settings**” icon to bring out the Settings page.

[Note] The internet connection is required for auto date and time adjustment.

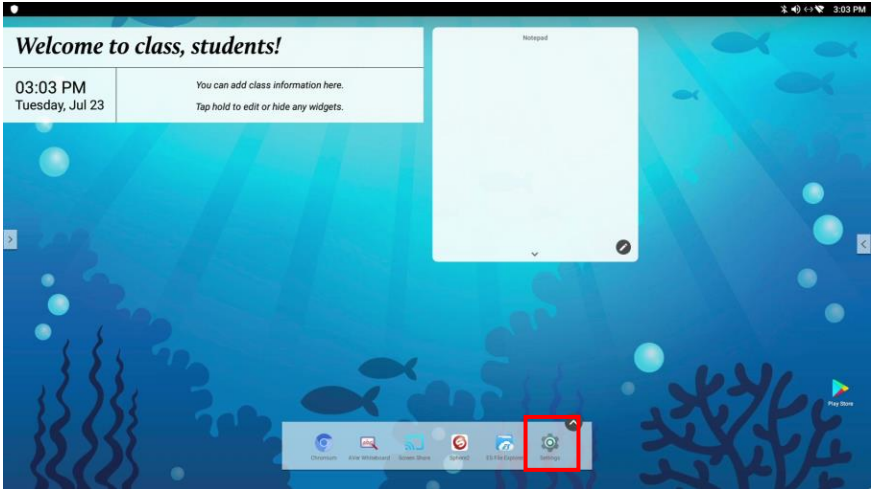

2. In Settings page, select “**Date & Time**”.

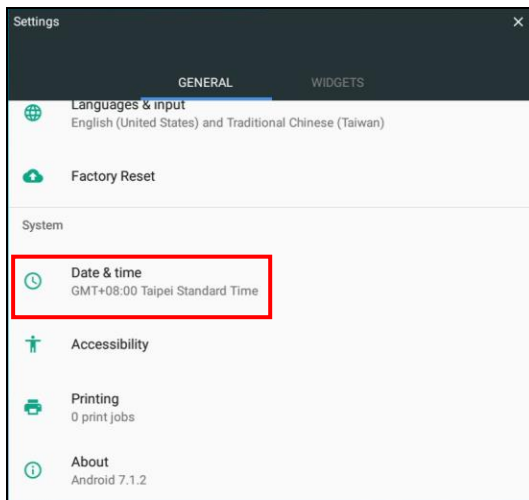

3. You can select “**date**”, “**Time**”, “**time zone**” and “**time format**” to setup.

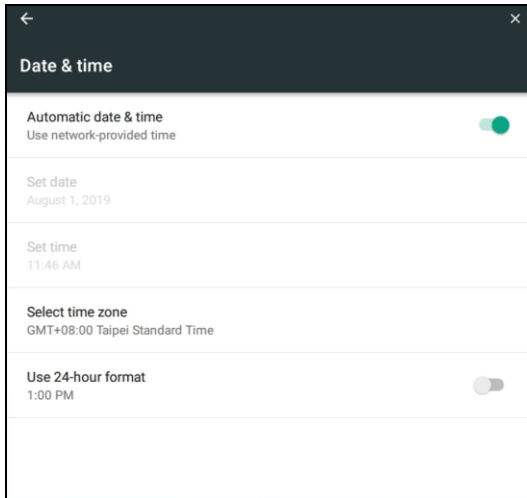

Power Saving

The AVer CB-310 provides two (2) type of power saving modes – Screen saver and Auto Backlight off.

Screen Saver

Enable AVer CB-310 to screen protect mode after AVer CB-310 system is idle in certain time.

1. Select **Settings > Display > Screen Saver**.

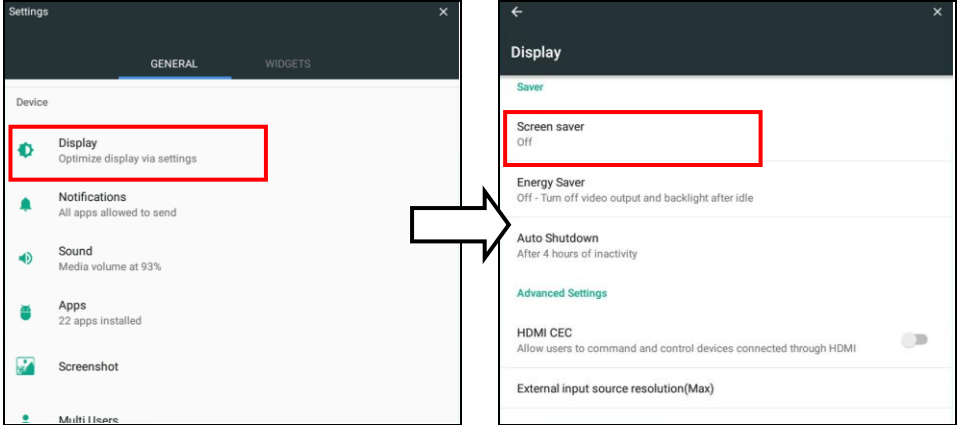

2. Enable the Screen Saver and select the screen saver display type – Clock, Colors, Photo Frame, or Photo Table.

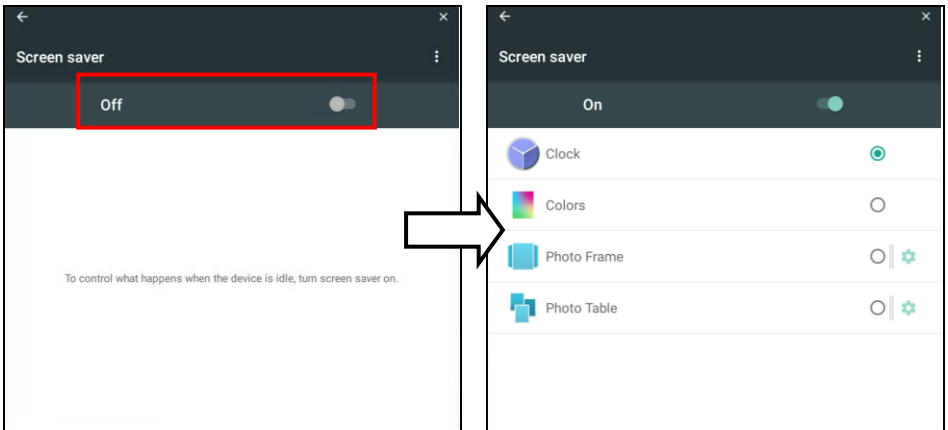

Energy Saver

The AVer CB-310w will turn the backlight off after certain idle time that user has set. While backlight is off, the apps and video outputs will be stop operating.

1. Tap **Settings > Display > Energy Saver**

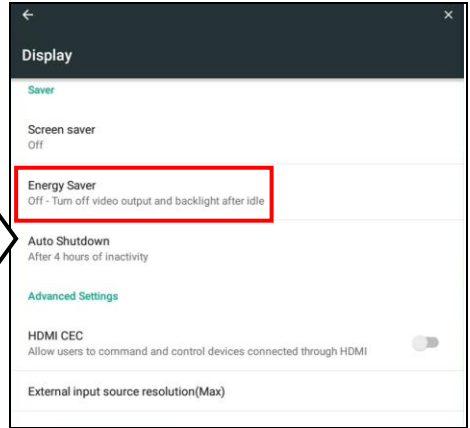
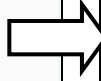
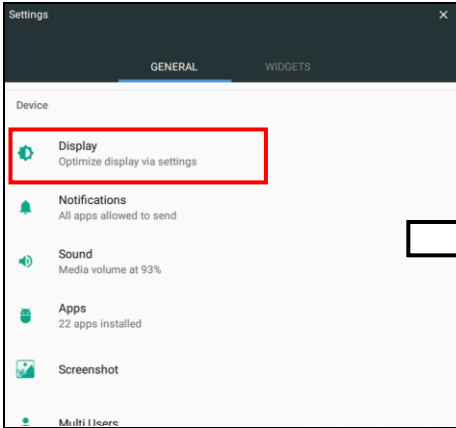

2. Enable the Screen Saver

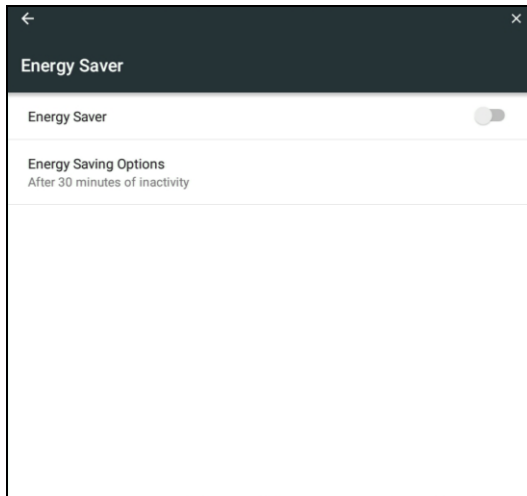

3. Select the “**Energy Saving Options**” to set the energy saver start time.

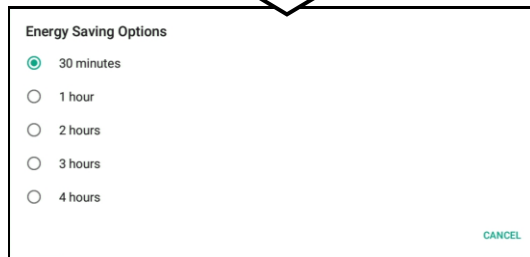
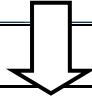
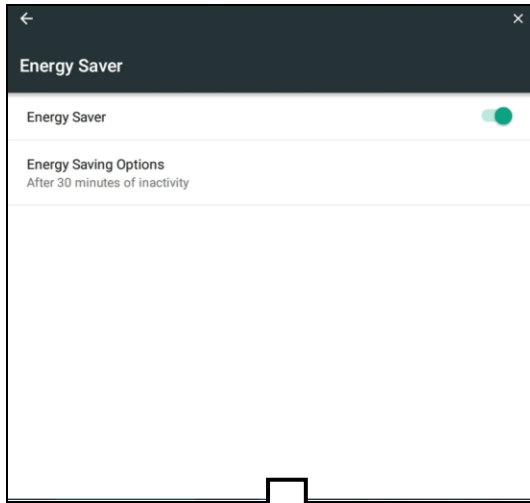

Screen Lock

Protect screen by password.

1. Select **Settings > Security > Screen lock**.

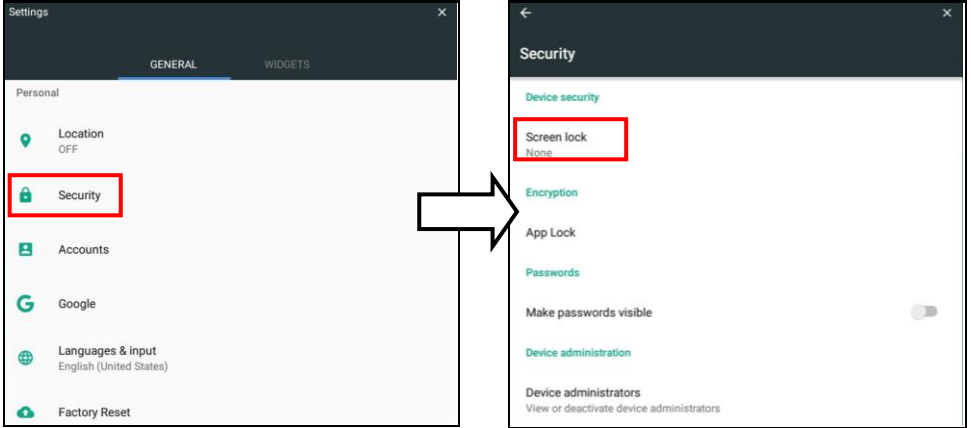

2. Select **“Password”** option to set password protection.

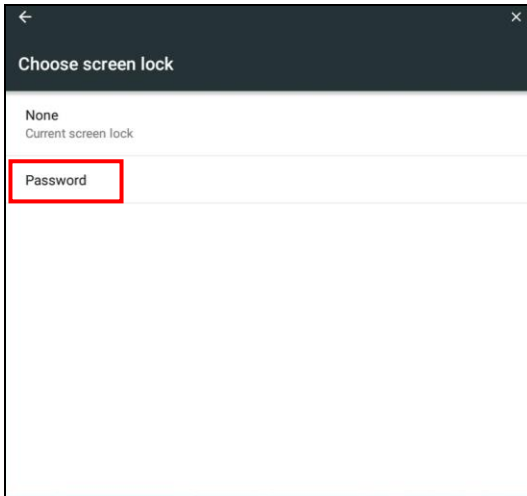

3. Enter the “New Password” and re-enter the password to confirm.

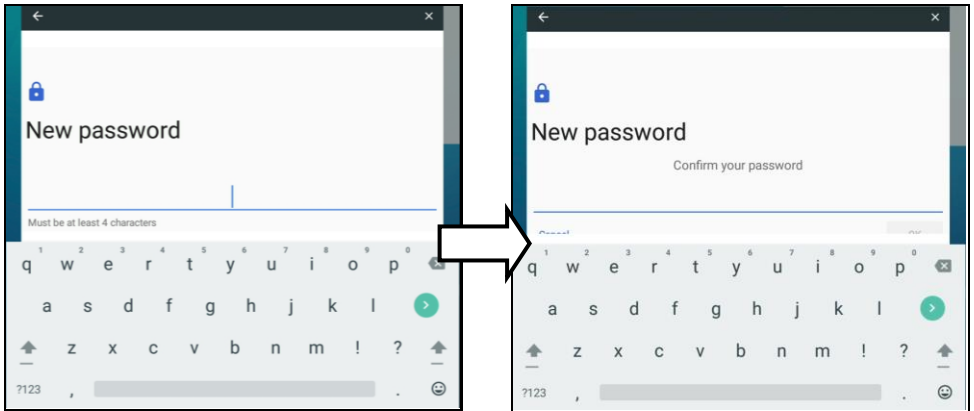

4. Screen lock has two modes – Automatically Lock and Power button instantly lock. User can set the time period for automatically lock.

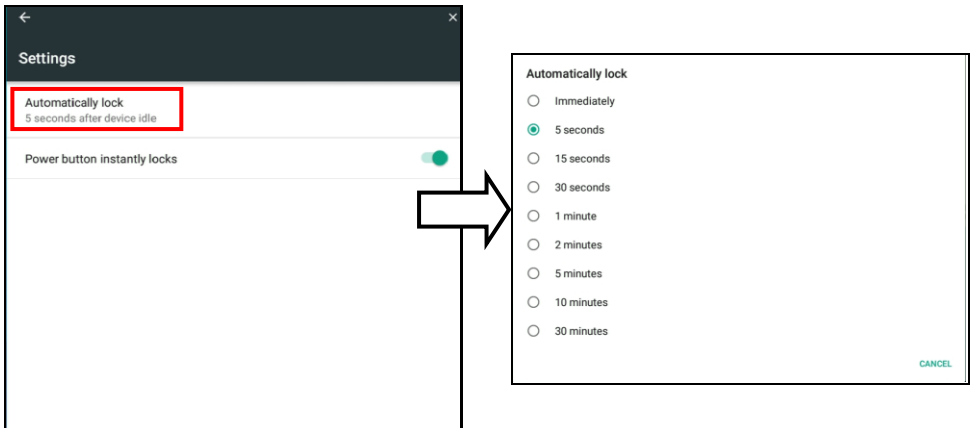

5. To disable screen lock, tap **Settings** > **Security** > **Screen Lock** and enter the password user has set. Then, select “None” to disable the screen lock.

App Lock

Protect the app with password.

1. Select **Settings > Security > App Lock**.

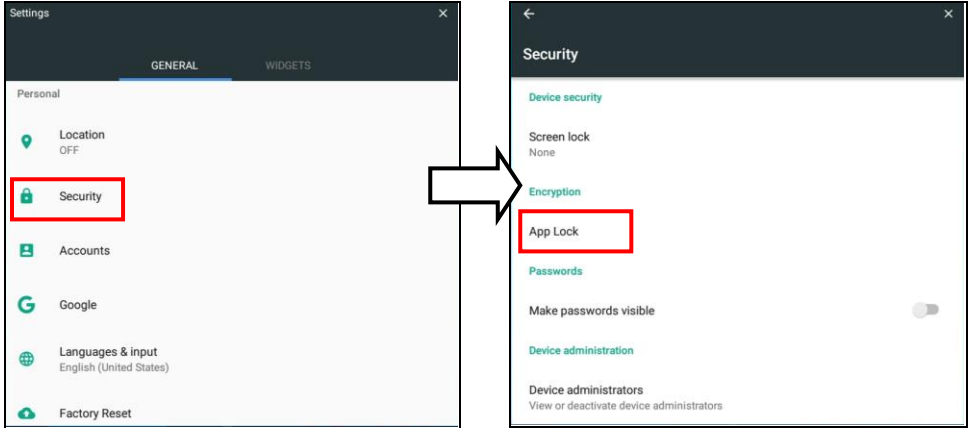

2. Enter the password that user wants to set.

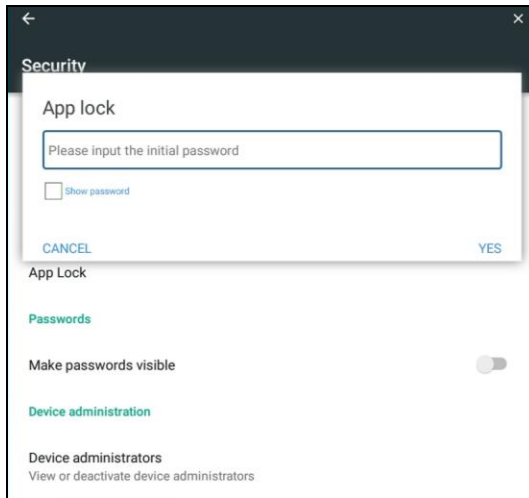

3. Select the apps that want to be protected by password.

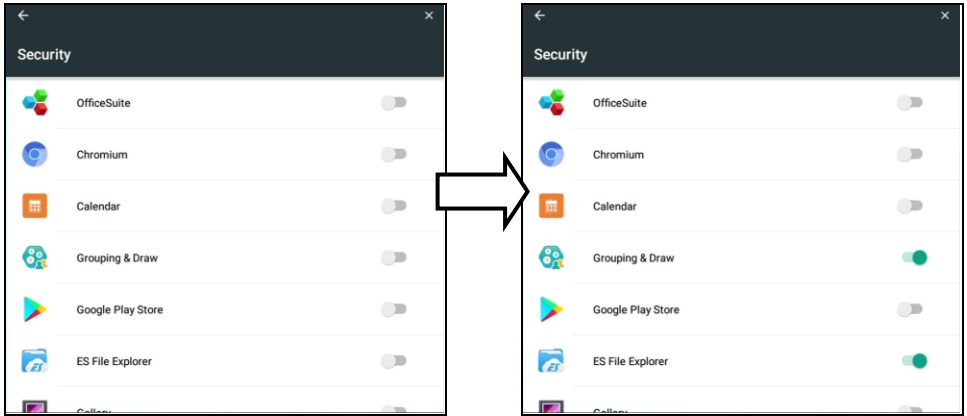

4. When user select the app has been locked, a password is required.

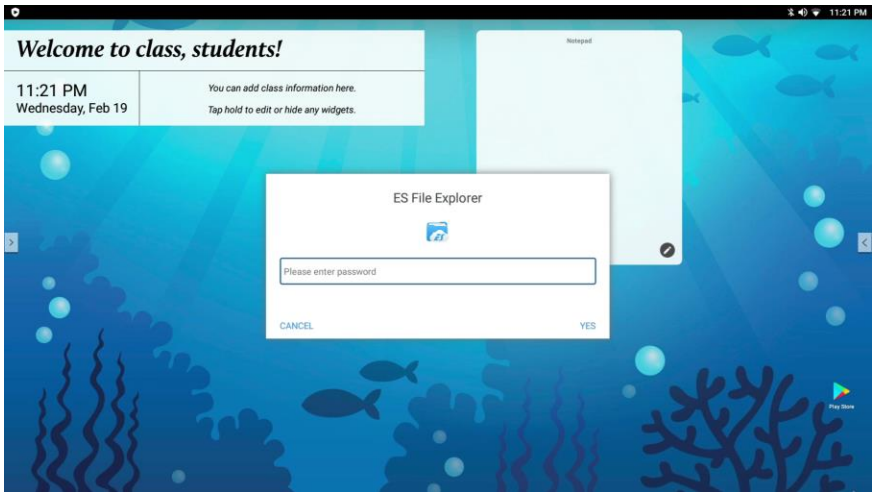

5. To un-lock the locked app, tap **Settings > Security > App Lock > Enter password > un-selected** the app.

6. **Change App Lock password.** Tap **Settings > Security > App Lock > Change password**. Enter the old password, then, enter the new password and re-enter new password to confirm. Tap “**YES**” to change the password.

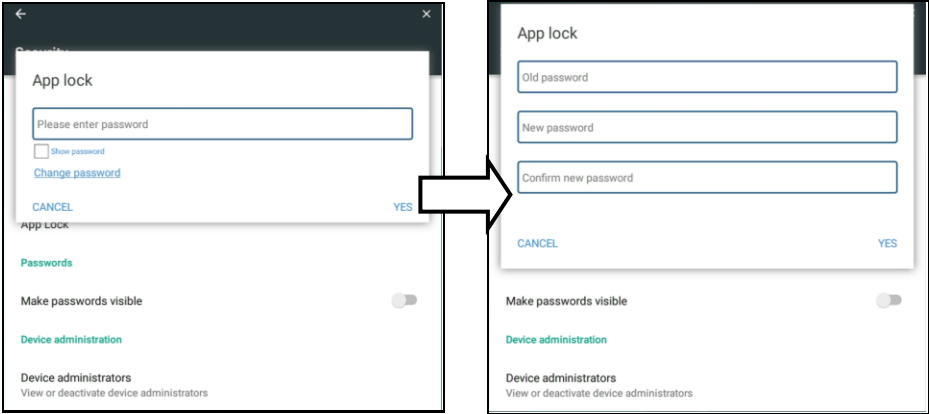



Blue Light Filter

Reduce the contrast for eyes relief.

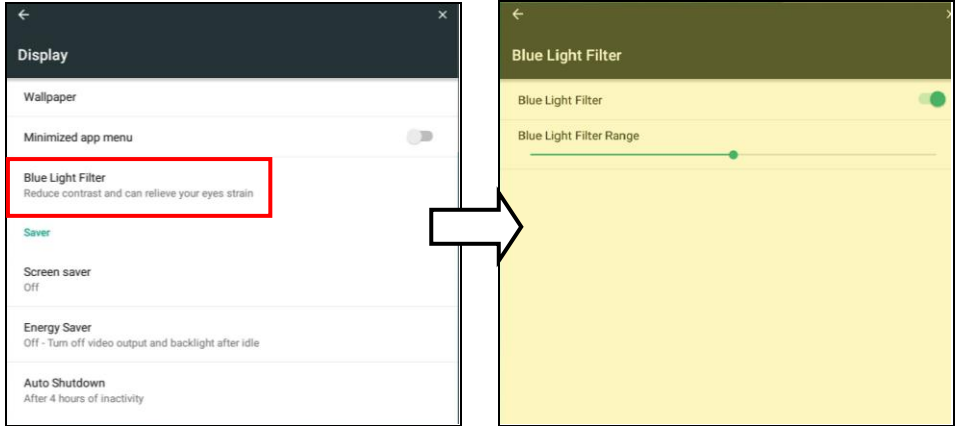
Select **Settings > Display > Enable the “Blue Light Filter”**. Move the dot to adjust blue light filter range.



Volume Adjustment

Press  and  on AVer CB-310 panel can adjust system volume. Or w ipe-down the notice column and expand it. Then, move the volume adjust bar to adjust volume.

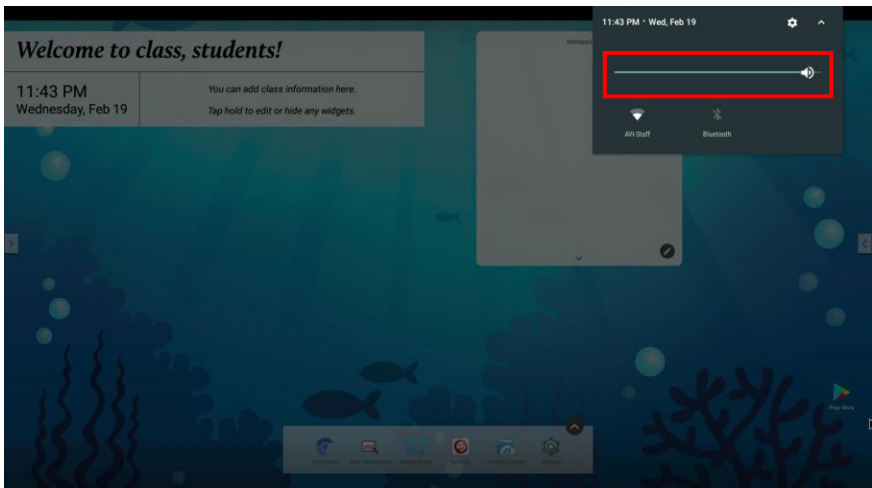

Wallpaper

Change the wallpaper.

1. Click and hold on the screen until the “**Wallpaper**” option is shown.

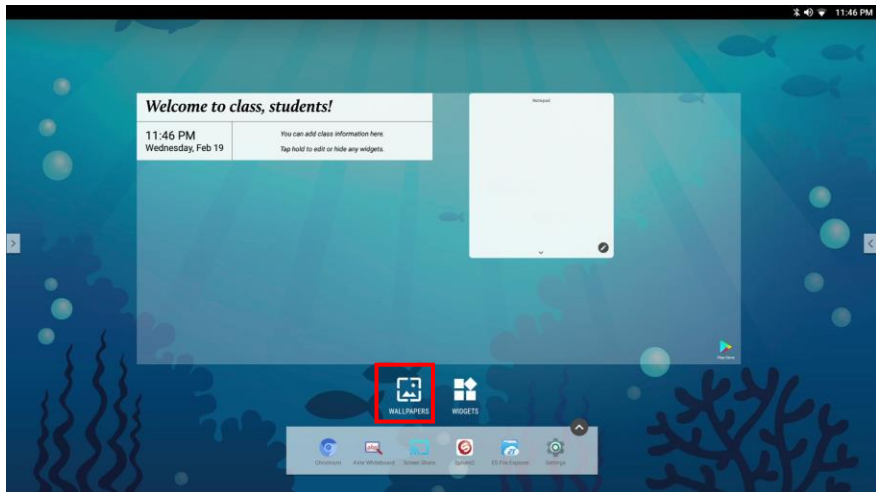

2. Select the “**Wallpaper**” and select the wallpaper in system default. Or select “**My Photos**” to select other picture to be the wallpaper.

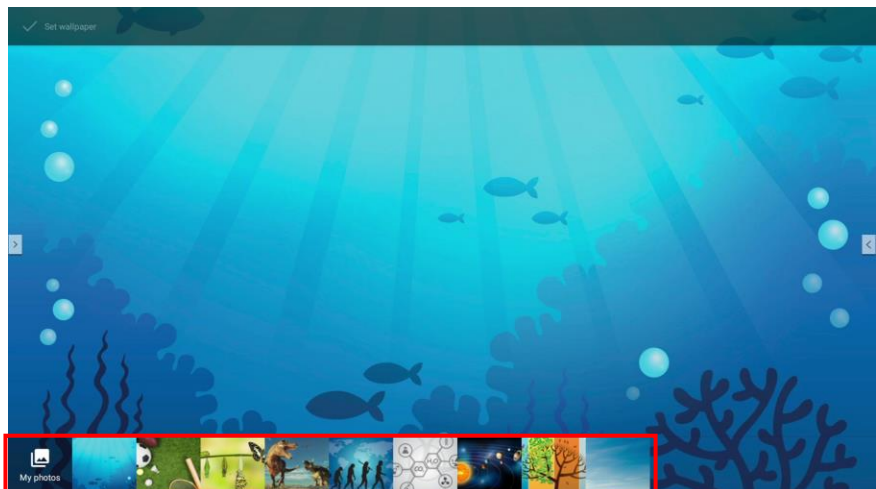

System Update

Select **Settings > About > System update** and systemupdate will start.

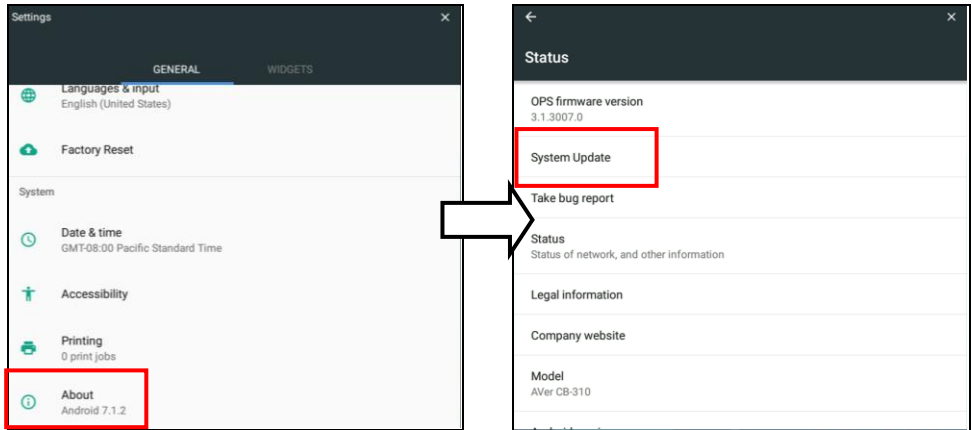

The systemupdate takes time; we recommend doing the systemupdate when the machine is not in use.

If there is no update, select “**Close**” to finish.

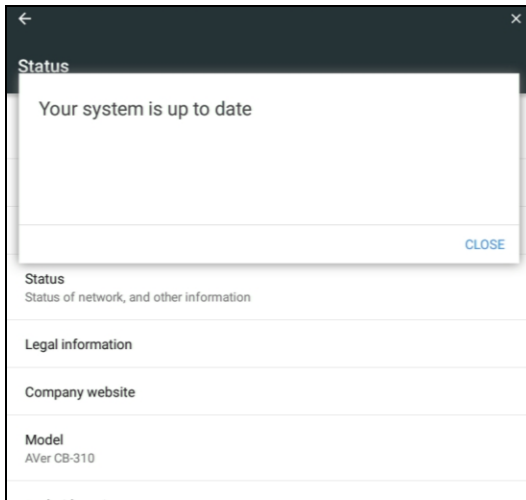

Display Management

To manage the AVer CB-310 devices on your LAN – manual power on/off/reboot AVer CB-310 and scheduling AVer CB-310 for power on/off/reboot.

[Note] An Ethernet cable connection is required for AVer CB-310 devices.

Please download the Display Management application from <http://www.aver.com/download-center>

Minimum Server System Requirements

- **Operating System** : Win 7 / Win8 / Win10
- **CPU** : Intel Core 2 Duo 2.00GHz or later
- **RAM** : 1 GB of RAM (2 GB recommended)
- **Resolution** : 1024 x 768 or higher resolution display
- **Graphic card** : DirectX 9.0c compatible video card
- **Hard Disk** : 500 MB free hard disk space for basic installation

Login

1. Run the AVer Display Management application.
2. The login dialog is displayed. Enter the password; for the first time login, the default password is “admin”.

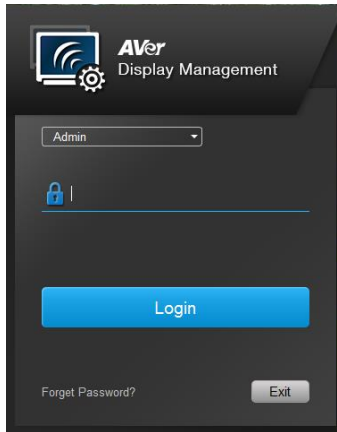

3. After entering the password, select “Login” to login.
4. Enter the email for sending password if forgot the password in future. Select “Enter” to login.

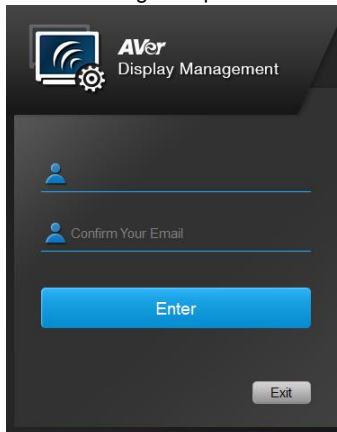

5. After login, the Display Management UI is displayed.

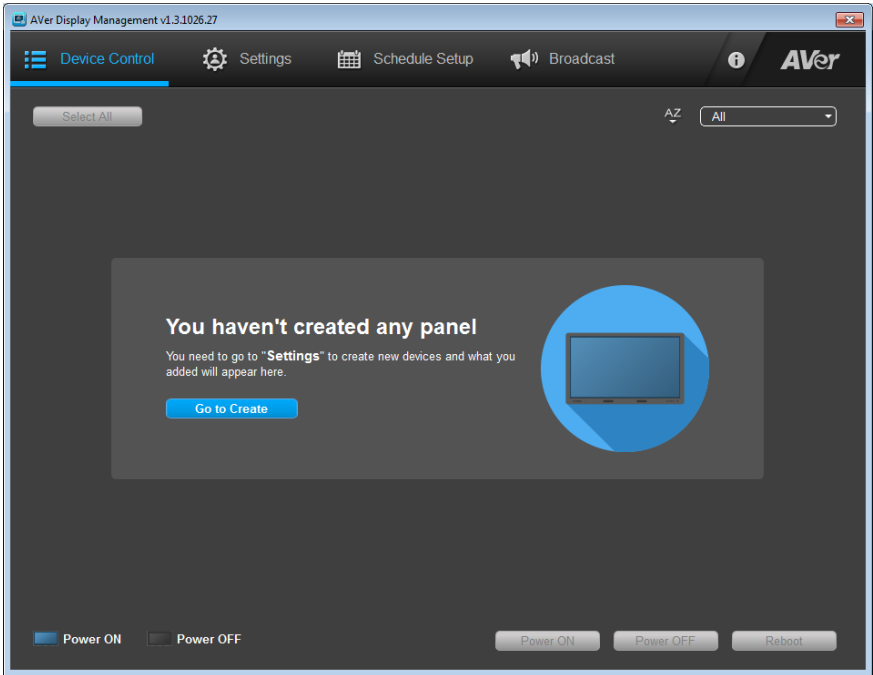

Change Password

1. Select “” icon.

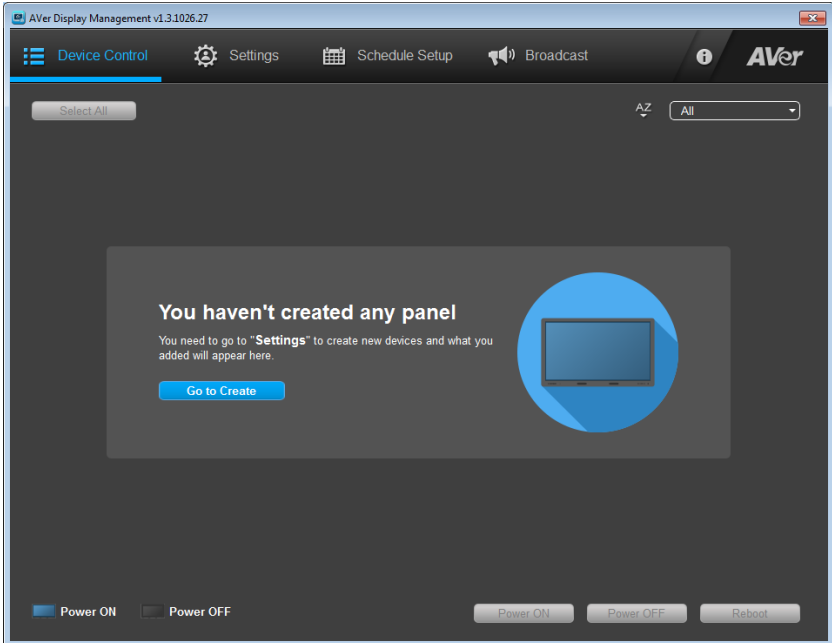

2. The email and password dialog will show up.

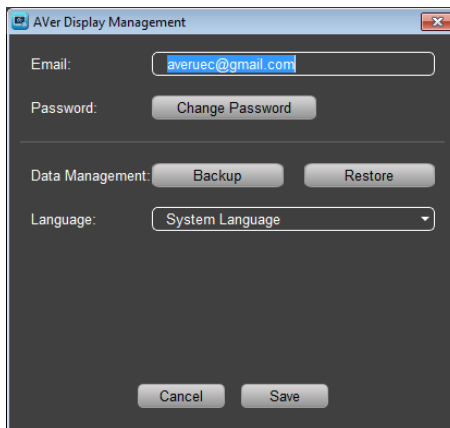

3. Select “**Change Password**”. Then, enter the new password and re-enter the new password to confirm.

4. Select **Save** to save the changes.

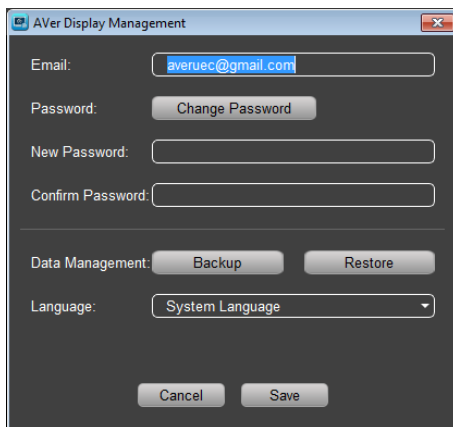

The screenshot shows a window titled "AVer Display Management" with a standard Windows-style title bar (minimize, maximize, close buttons). The window has a dark gray background and contains the following elements:

- Email:** A text input field containing the email address "averuec@gmail.com".
- Password:** A button labeled "Change Password".
- New Password:** An empty text input field.
- Confirm Password:** An empty text input field.
- Data Management:** Two buttons, "Backup" and "Restore", positioned side-by-side.
- Language:** A dropdown menu currently showing "System Language".
- Buttons:** At the bottom of the window, there are two buttons: "Cancel" and "Save".

Change Email

1. Select “” icon.

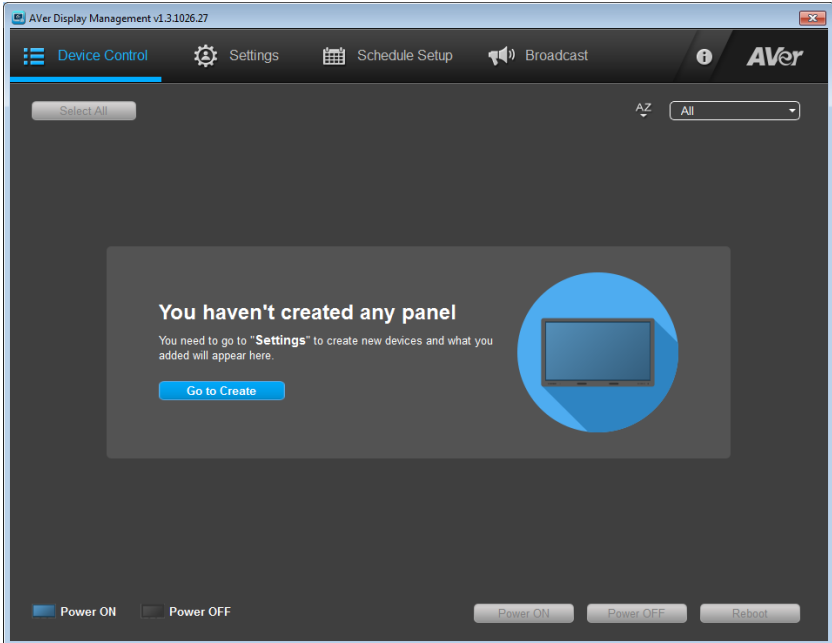

2. The email and password dialog will show up.
3. Enter the new Email address. Then, select “**Save**” to save the changes.

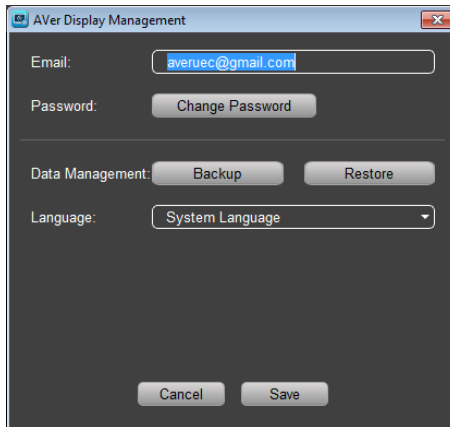

Add AVer CB-310 Device

1. Select “**Settings**”.
2. Click “**Add Device**”.

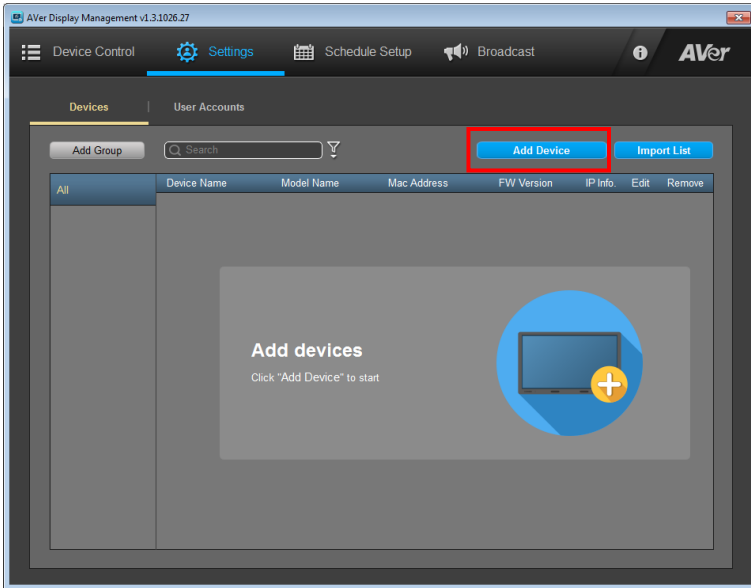

3. In Add Device dialog, you can choose “**IP Address Search**”, “**Auto Detection**”, or “**Mac Address Search**” to find the AVer CB-310 on your LAN network.

[Note]

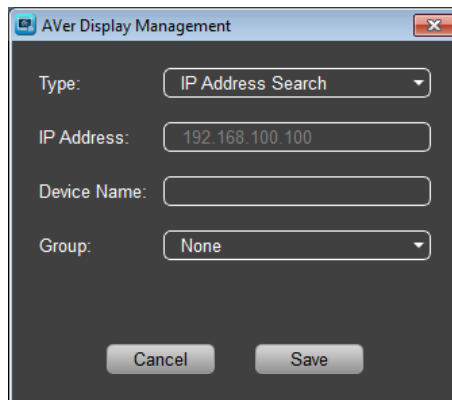

- a. An Ethernet cable connection is required for AVer CB-310.
- b. The AVer CB-310 and Display Management must be in the same network.

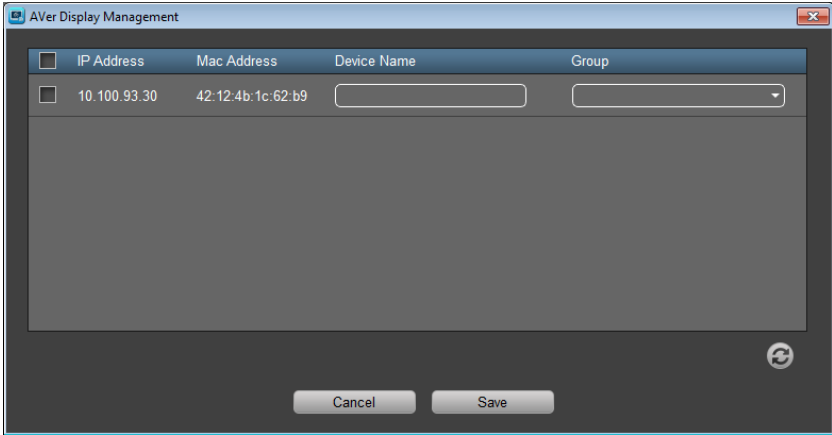

4. The search result will be listed. Select the AVer CB-310 and enter “**Device Name**” and select the “**Group**” if there are groups for selecting.
5. Select “**Save**” to add.



6. The added AVer CB-310 will be listed in device list.

- ✓  : View AVer CB-310 IP, mask, and gateway information.
- ✓  : Edit AVer CB-310 device name.
- ✓  : Delete AVer CB-310 from device list.

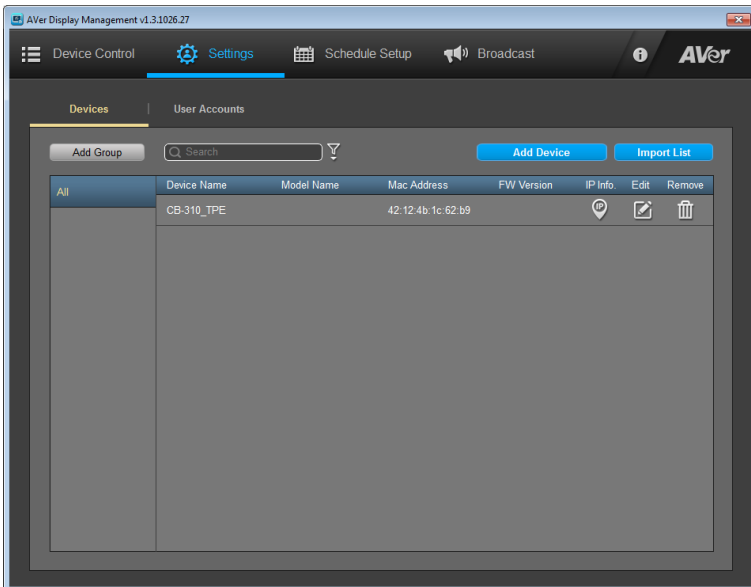

Filtering AVer CB-310 Device

To find added AVer CB-310 devices by searching condition or keyw ord.

Select the filter condition – Device Name, Model Name, Mac Address, FW Version or IP info or enter the keyw ord to filter. Then, the filter result w ill display.

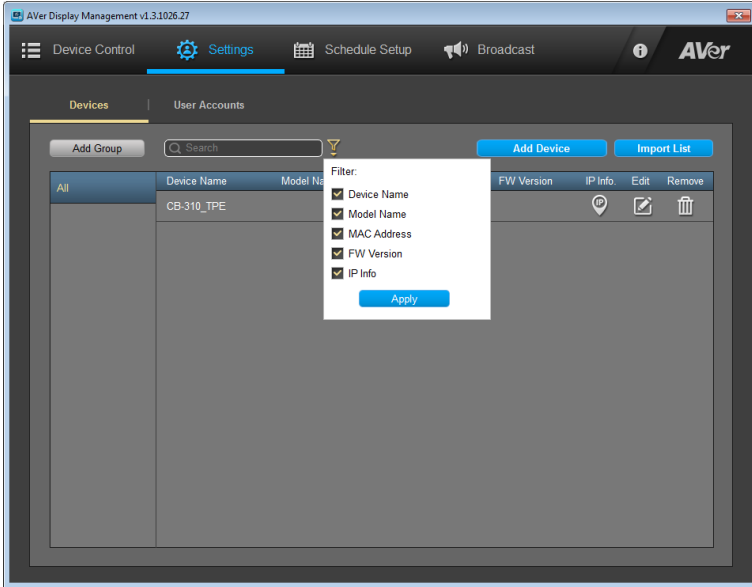

Add Group

Create the group and assign AVer CB-310 devices to specific group for managing.

1. Select “**Add Group**” in Settings screen.

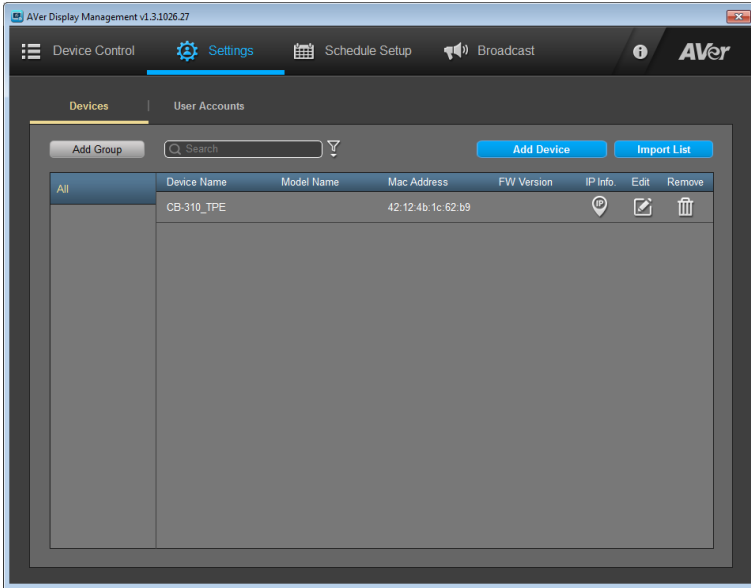

2. Enter the group name in Group dialog and select “**Save**”.

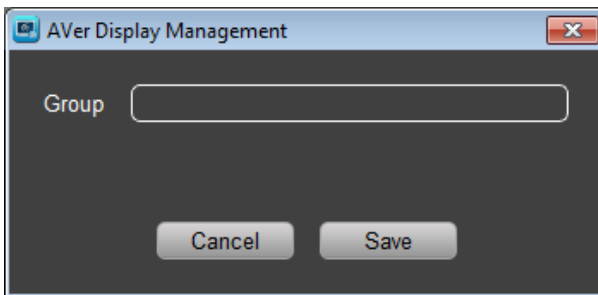

3. The created group will list at left side of Settings screen. Select the group to view the AVer CB-310 devices in the group. When add AVer CB-310 device, you can assign AVer CB-310 device to the group.

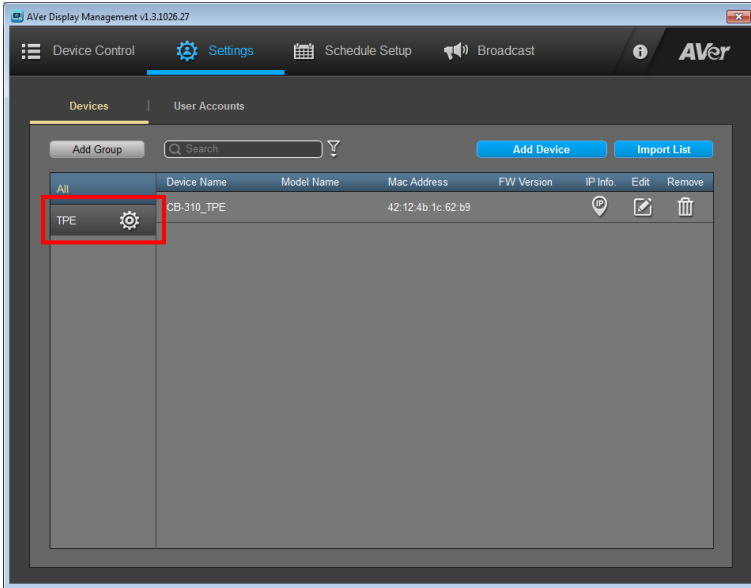

4. Select “” can edit and delete group. Edit can change the group name.

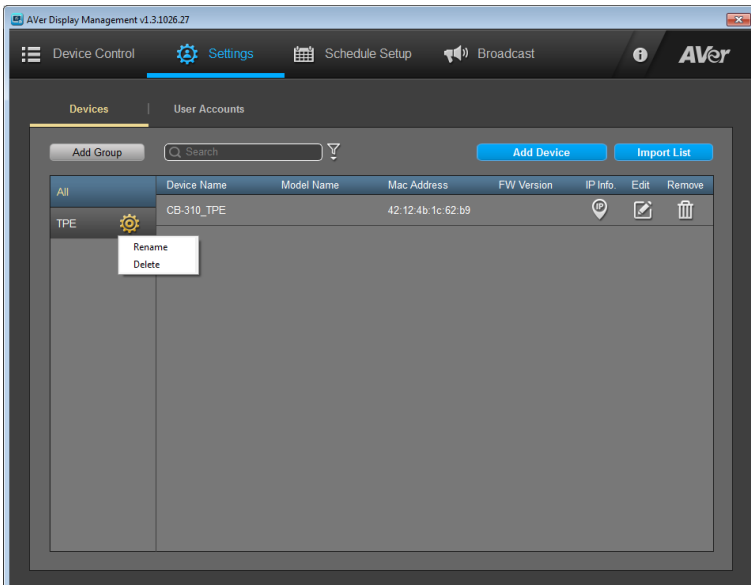

Power On, OFF, and Reboot AVer CB-310 Device

In Device Control screen, display the AVer CB-310 devices that have added into Display management app. You can manually power on, power off, and reboot the AVer CB-310 devices that list in Connected List screen.

[Note]

- a. An Ethernet cable connection is required for AVer CB-310 devices.
- b. The AVer CB-310 devices and Display Management must be in the same network.
- c. The Display Management app must be running in order to control the AVer CB-310 devices on/off/reboot.
- d. UDP port 9 of Wake On LAN cannot be blocked.

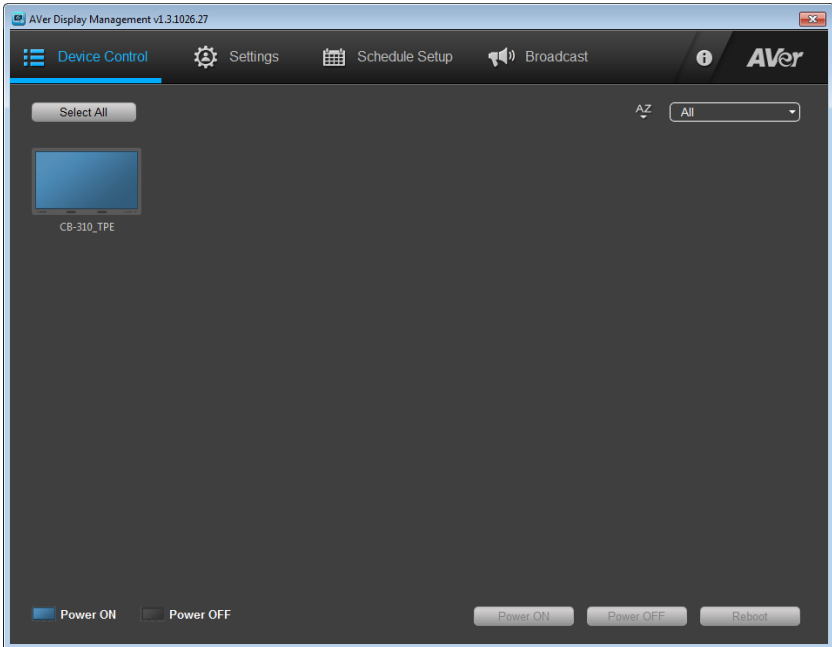

1. Select “**Device Control**”.
2. Select the AVer CB-310 devices from screen list or select “**Select All**”. The selected AVer CB-310 device will be marked. Then, select “**Power on**”, “**Power Off**”, or “**Reboot**” button to execute.

[Note]

- a. After selecting AVer CB-310 device, the power on, power off and reboot button will be enabled.
- b. The AVer CB-310 devices display order can be change by select A-Z order or group (drop-down list).

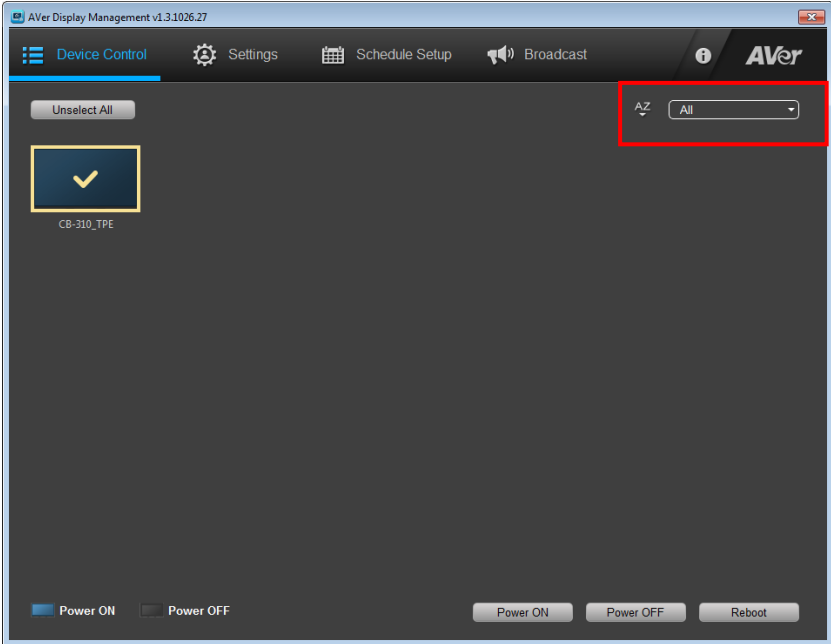

Scheduling

Set the specific day and time to power on, power off, and reboot the selected AVer CB-310 devices. The schedule will execute until you disable the schedule.

[Note]

- a. An Ethernet cable connection is required for AVer CB-310 devices.
- b. The AVer CB-310 devices and Display Management must be in the same network.
- c. The Display Management app must be running in order to control the AVer CB-310 devices on/off/reboot.

1. Select **“Schedule Setup”**.
2. Select **“Add Schedule”** > **“Device Control”**.

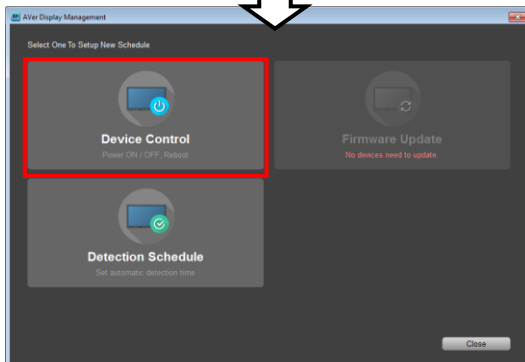
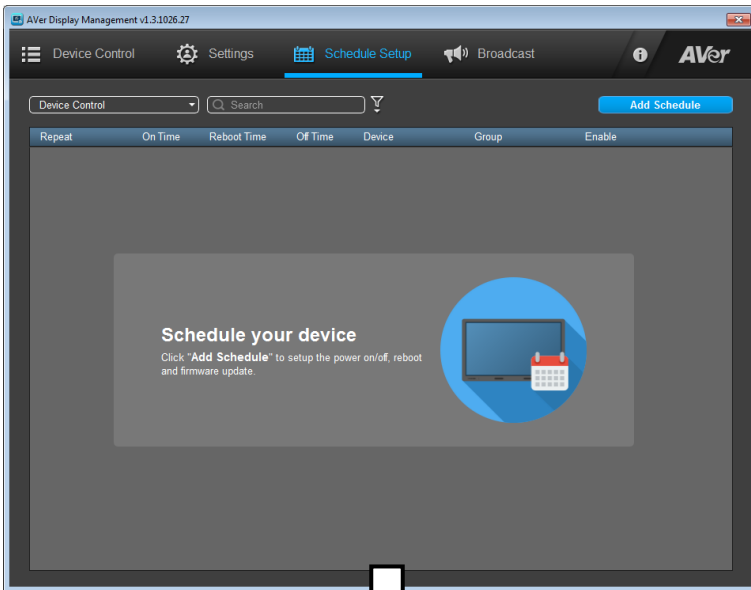

3. **Select the Day:** Every Day, Mon, Tue, Wed, Thu, Fir, Sat, or Sun.

[Note] When select ‘Every Day’ schedule, Mon to Sun w ill be all marked. If un-select one of day, then, the ‘Every Day’ schedule is invalid.

4. **Select the action:** On Time, Reboot Time, or Off Time. Then, set the time (HR:MIN) for action.

5. **Select Device:**

- ✓ **All** : Select all AVer CB-310 devices.
- ✓ **Group**: Select AVer CB-310 devices by group.
- ✓ **Select Device**: Select AVer CB-310 device one by one from AVer CB-310 device list.

[Note] Use filter function to find the AVer CB-310 devices if you know AVer CB-310 device's name or group.

6. Select **“Save”** to save the schedule.

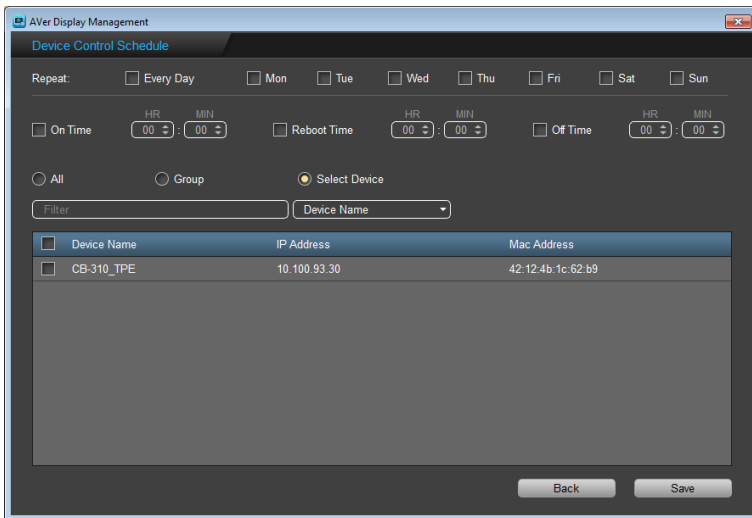

7. From Enable drop-down list, select “Disable” can stop schedule to run.

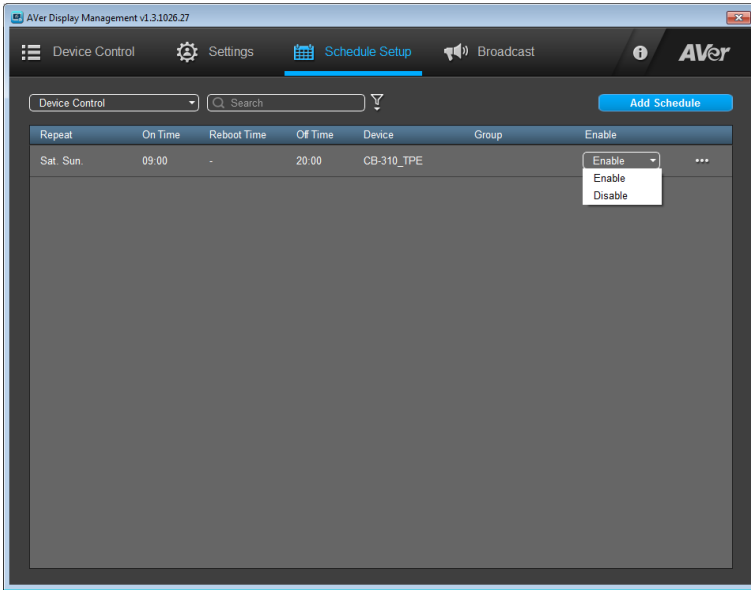

8. Select “...” can modify and edit schedule’s setting.

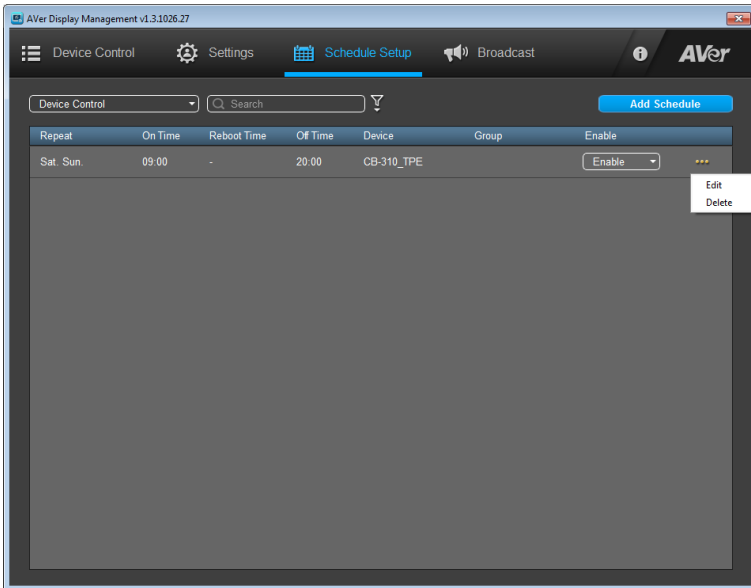

Firmware Update

Update the AVer CB-310 firm ware by scheduling or update now.

Scheduling the Firmware Update

Set a schedule to update the selected AVer CB-310 devices.

1. Select **“Schedule Setup”** > **“Add Schedule”**.

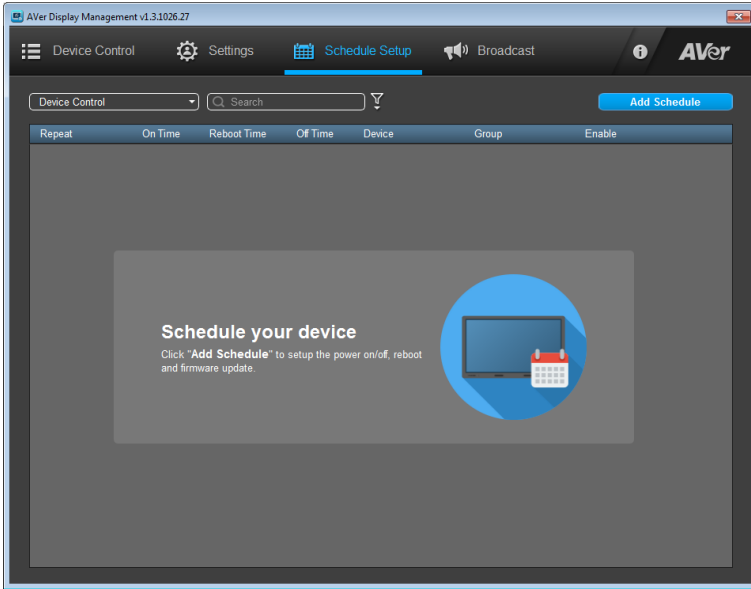

2. Select **Firmware Update**. The firmware update dialog is displayed.

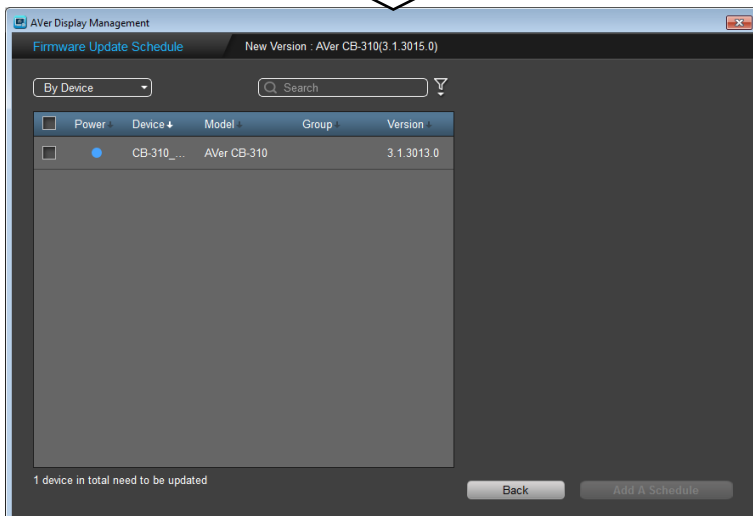
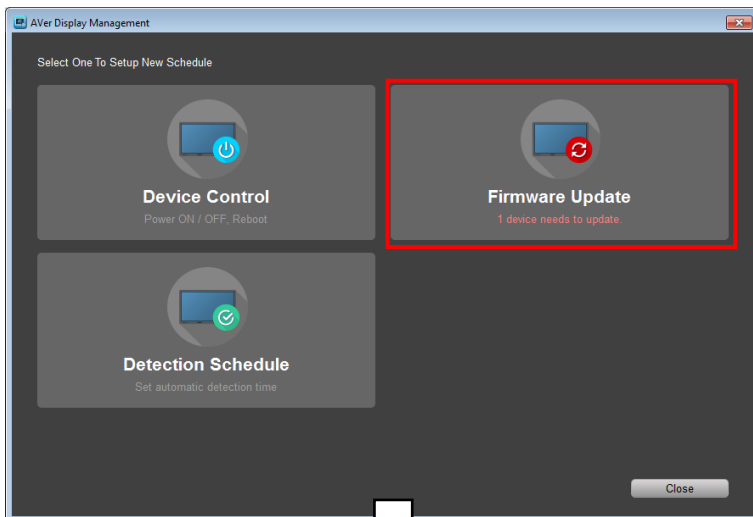

3. Select the AVer CB-310 device and set the date and time for firmware update.

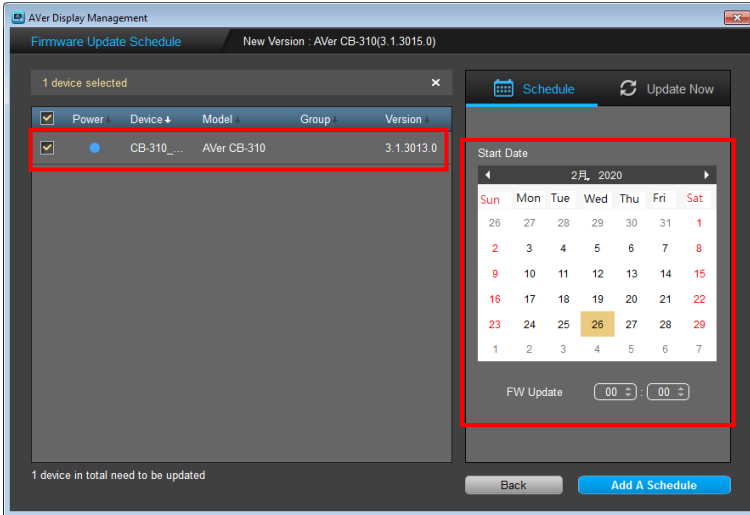

[Note] To find the AVer CB-310 device, use filter condition or enter keyword to find.

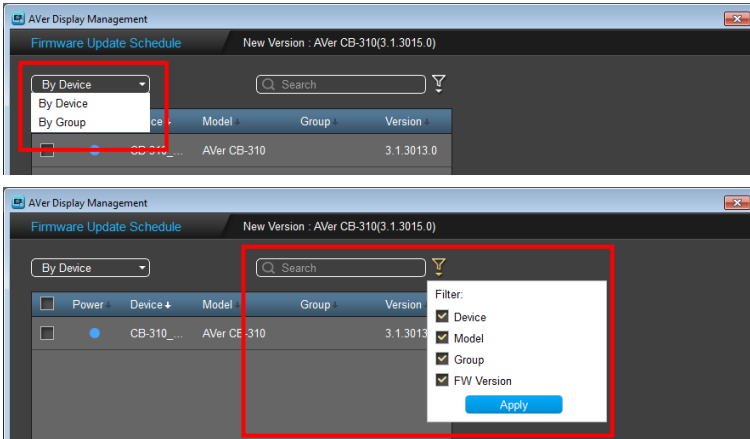

4. Select **"Add Schedule"**. The firm ware update schedule will be added to the list.

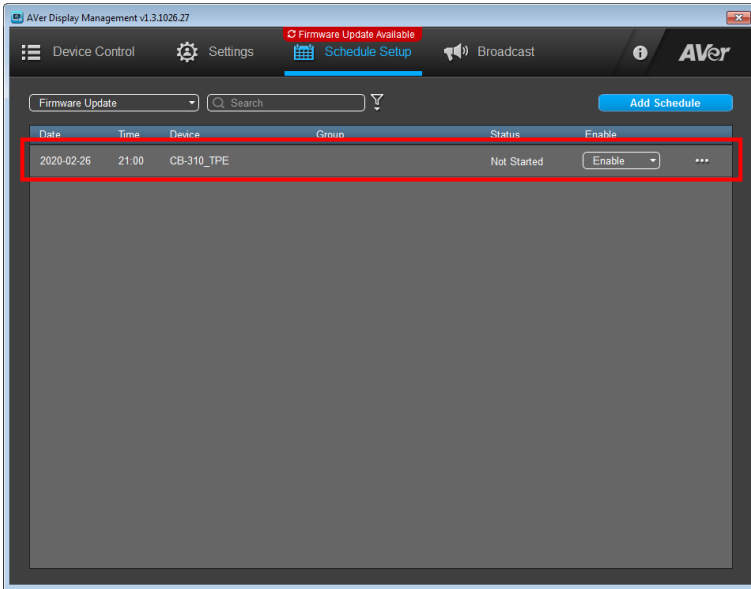

5. To disable the firm ware update schedule, select **"Disable"** from drop-list.

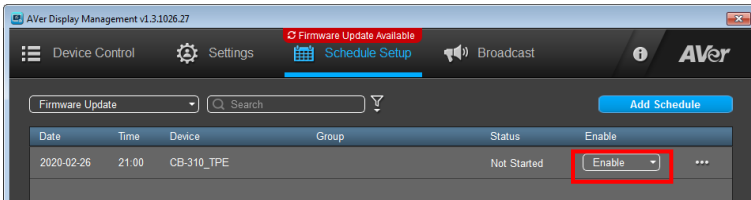

6. Select **⋮** can delete, edit and view report.

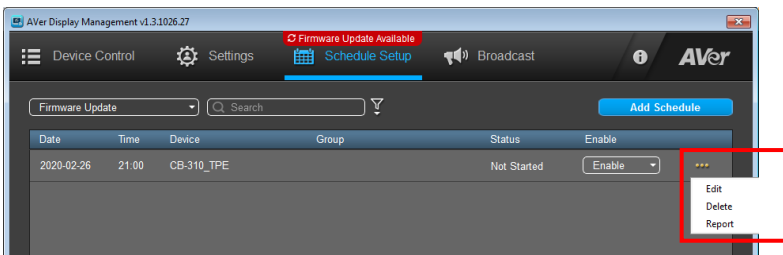

Update Firmware Now

When Display management has detected new firm ware available, user can update AVer CB-310 device firm ware immediately.

When a new firm ware is available, Display Management will show the notice on screen to inform user.

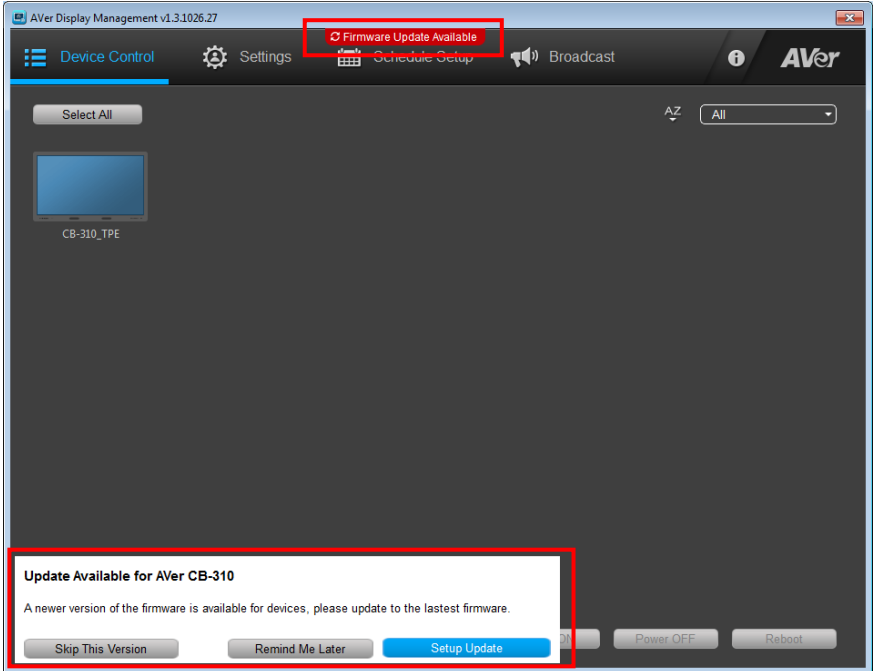

Select **“Setup Update”** or select **“Schedule Setup” > “Add Schedule” > “Firmware Update” > “Update Now”**.

The update screen will display.

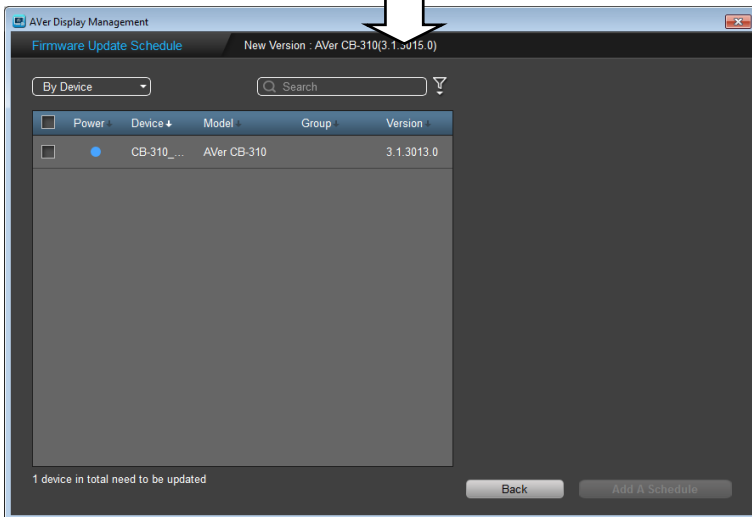
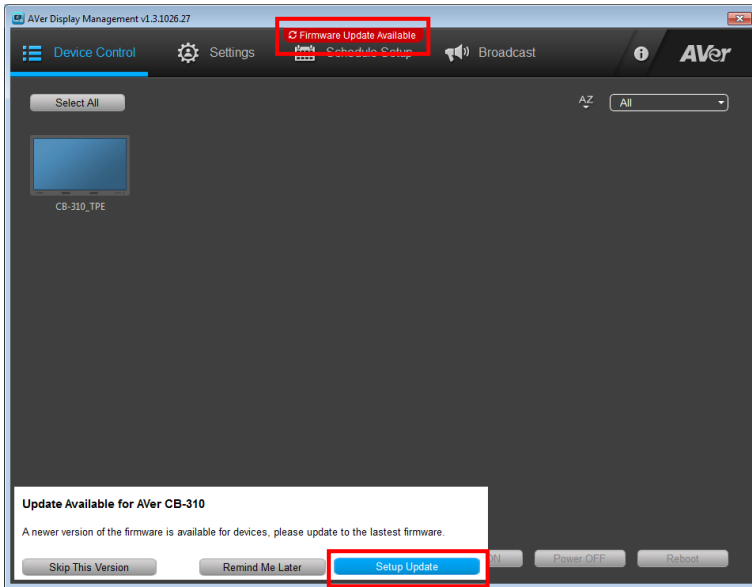

Select the AVer CB-310 device and select “Add Schedule” The update will be progressed. In firmware update list, user can see all devices’ firmware status – Successfully, Not Start, Failed, and Updating.

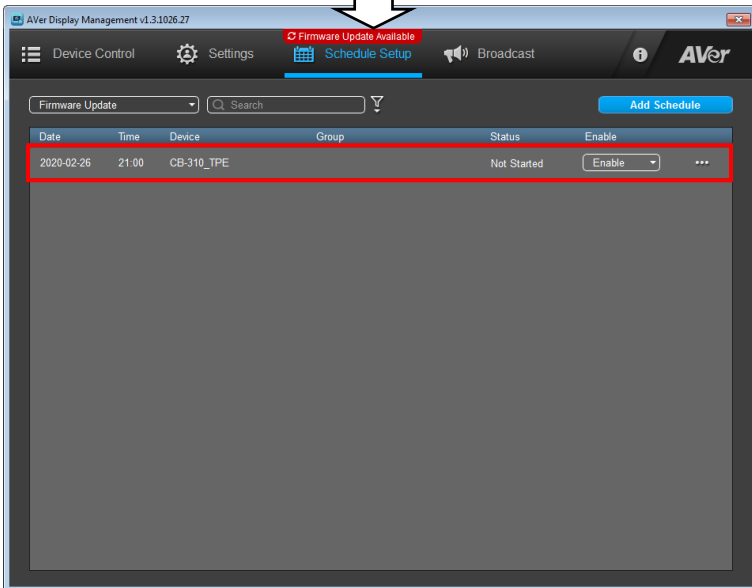
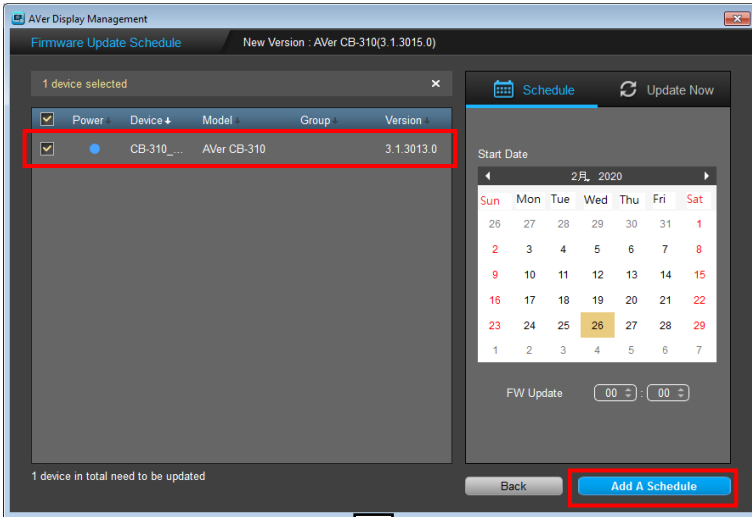

View Update Report

User can view the report of firmware update.

1. In Schedule Setup page, select “Firmware Update” from drop-down list.

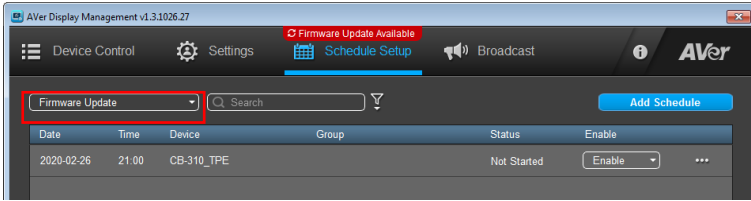

2. Select  > Report.

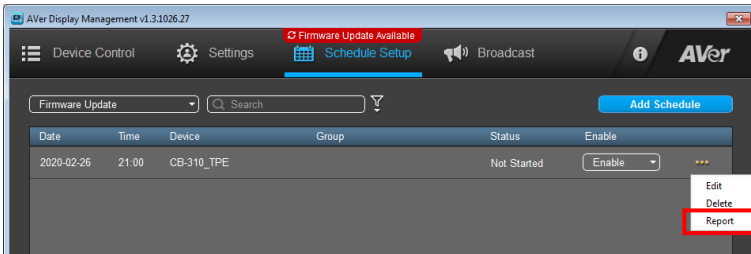

3. In report, list all devices' firmware update status. Select the tap page to view in different status.

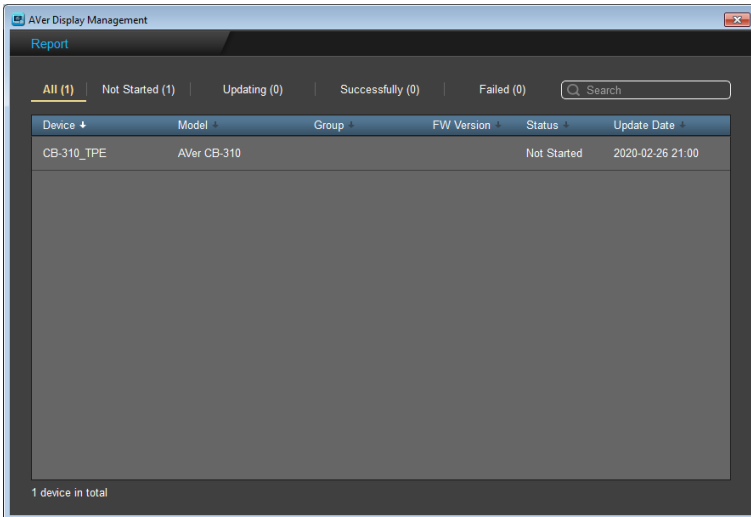

Broadcast

Set a message or audio message at specific time to broadcast on the specific AVer CB-310 device.

1. Select “**Broadcast**”.
2. Select “**Add Broadcast**”.

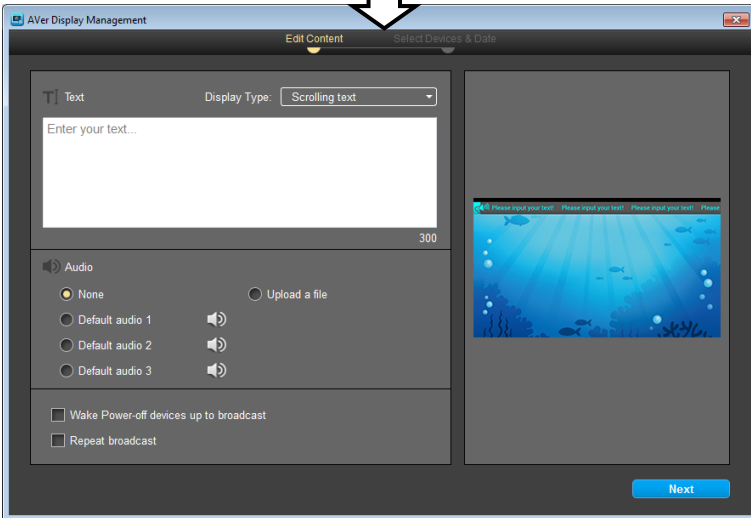
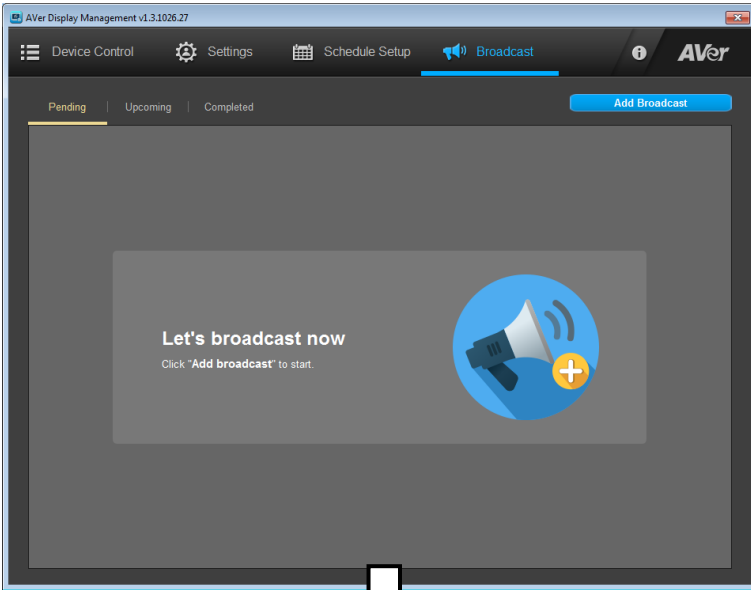

3. Setup the following options. After setting, select “Next” to go next step.
- **Text:** Enter the text message, maximum is 300 characters.
 - **Display Type:** Select the type of broadcast – scrolling text, pop windows, only audio.
 - **Audio:** Audio selections have “None”, “Default 1”, “Default 2”, “Default 3”, and “Upload file”.
 - **Wake Power-off device to broadcast:** To power on the AVer CB-310 device for broadcasting when device is power off.
 - **Repeat broadcast:** Broadcast will repeat to play in setup time period. The default time period is 30 seconds.

Repeat broadcast : Duration mins secs

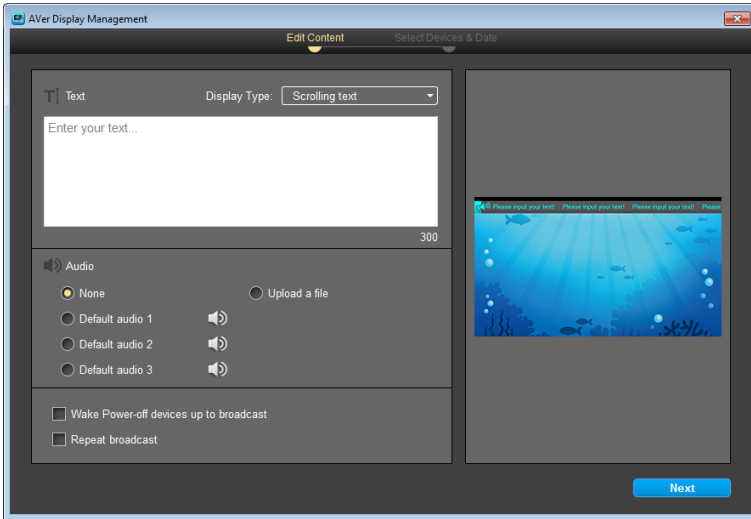

4. **Select device**

- User can select “By Device” or “By Group” from drop-down list to find the device.

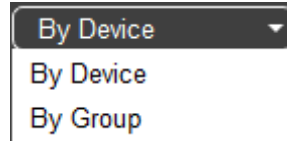

- Enter the keyword to find the device



- Filter: Select “Device” or “Group” to find the device.

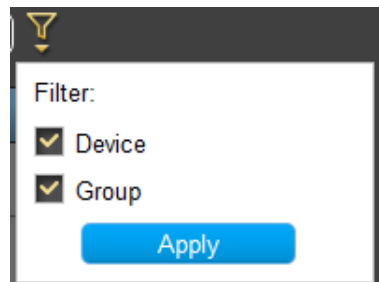

- Select text in the status bar can sort the order. When arrow is in bold with, it means current selection.

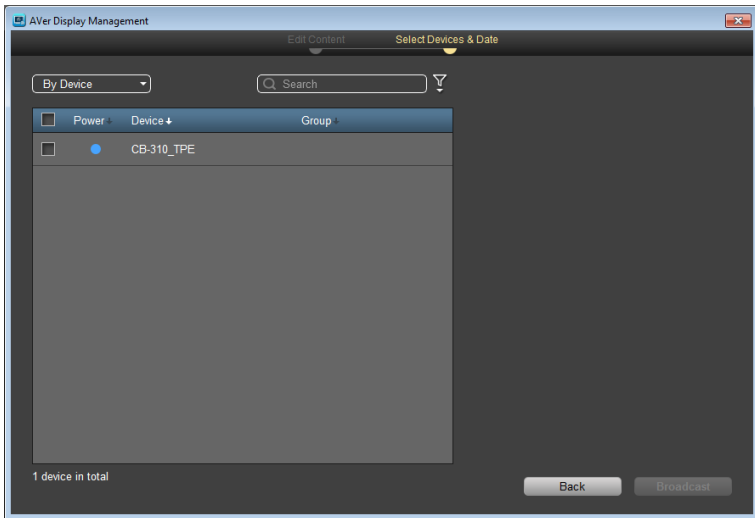
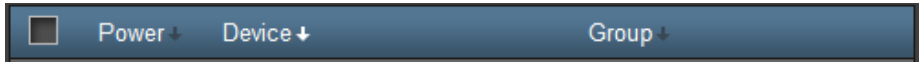

5. **Schedule:** Setup broadcast time. After selecting the device, the schedule windows will display. Select date, hour and minute to set the broadcast time.

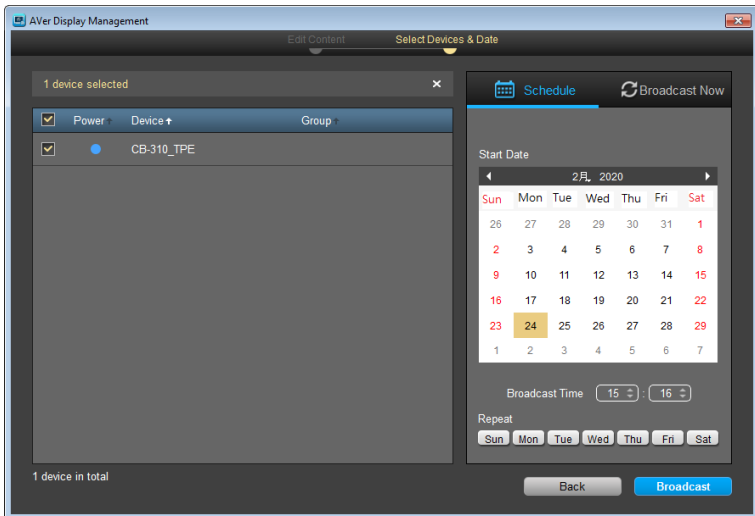

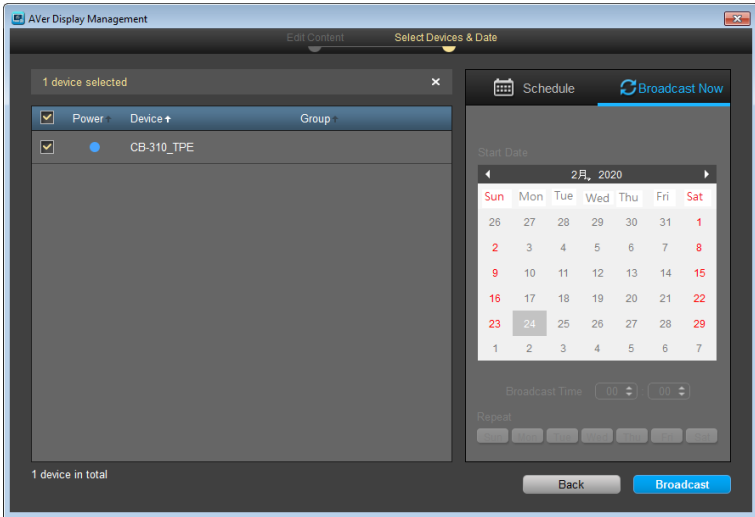

6. After setting broadcast schedule, select “**Broadcast**” to complete.
7. **Broadcast Now** : After selecting the device, select “**Broadcast**” and the broadcast will play immediately.



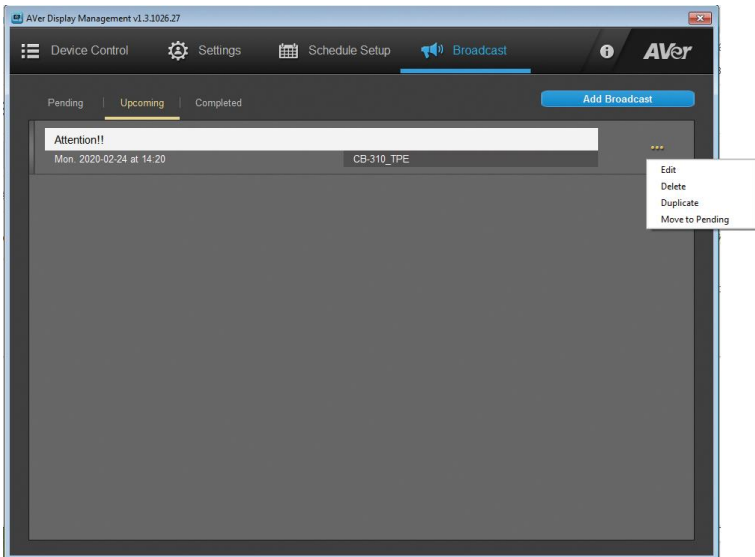

Broadcast List

- **Upcoming**: List the broadcasts not play yet. User can “Edit”, “Delete”, “Duplicate” and “ Move to pending”.

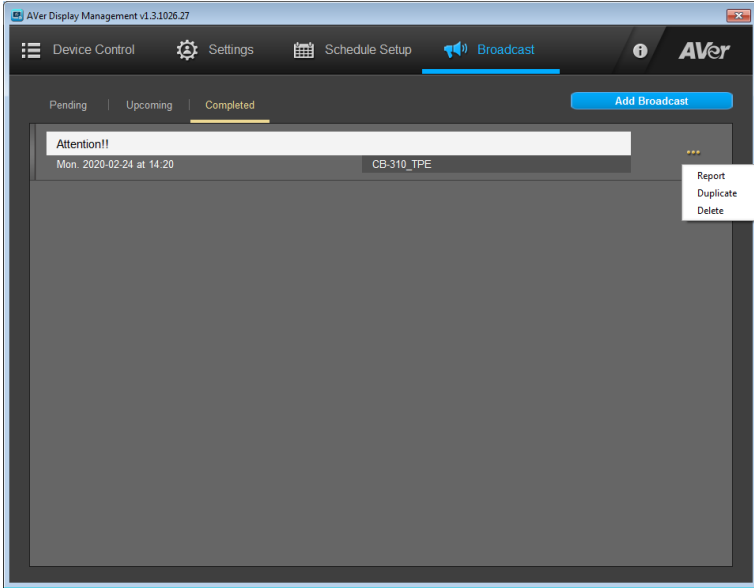

- **Completed: Broadcast has been play. User can select**  to check “Report” or “Duplicate”, “Delete”. Select  can play audio message.



- **Pending:** The broadcast is un-complete setting. User can select  > “Edit” to complete the setting. To delete, select “Delete”. Select “Duplicate” can copy the broadcast to edit as another broadcast.

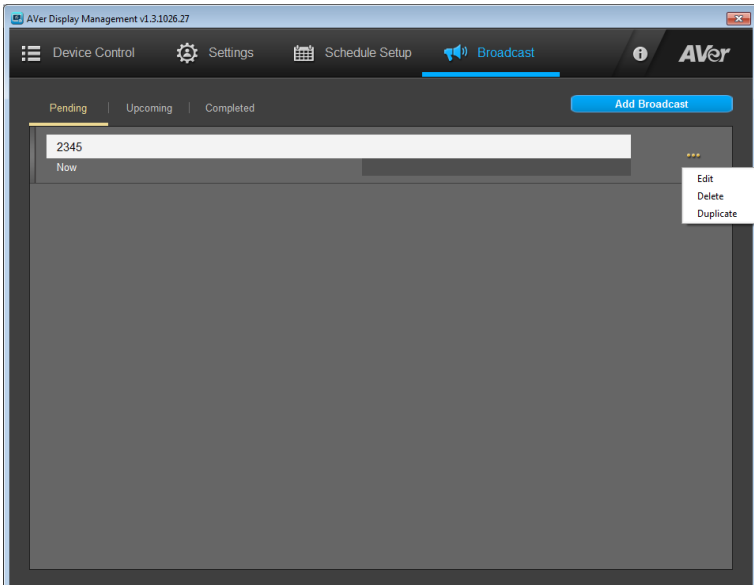

User Account

To create user account and synchronize with AVer CB-310 device.

Select “**Settings**” > “**User Accounts**”.

Maximum accounts are 50.

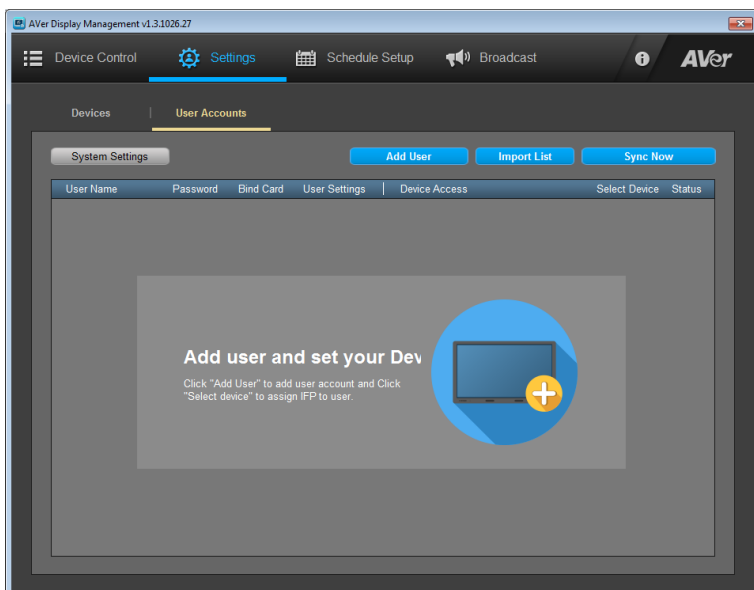

Enable Setup from Server

Enable remote management function to synchronize with AVer CB-310 device.

1. Select “SystemSettings”.
2. Enable “**Setup from Server**” and “**Multi-user function**”. When enable multi-user function, the password is required. After enabling, Admin password function is enabled, too. If user wants to change admin password, select “**Change Password**”.
3. 點選「儲存」儲存設定。

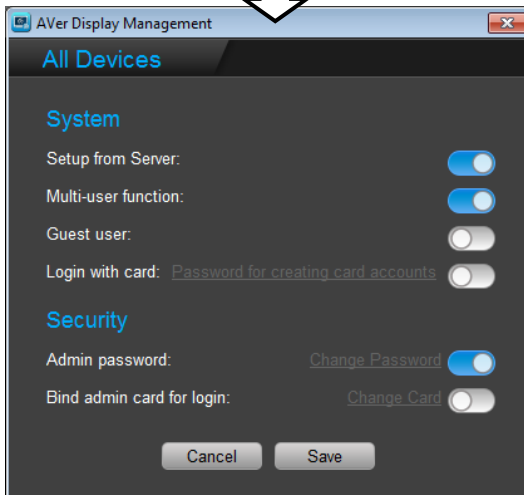
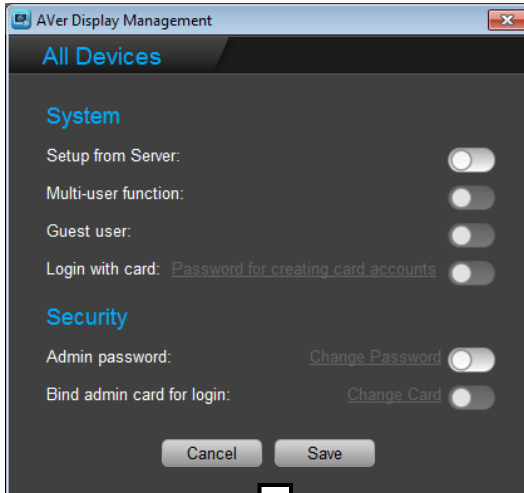

Add User

1. Select “Add User”.
2. Enter “User Name”, “Password” and “Confirm Password”. Then, select “Next”.

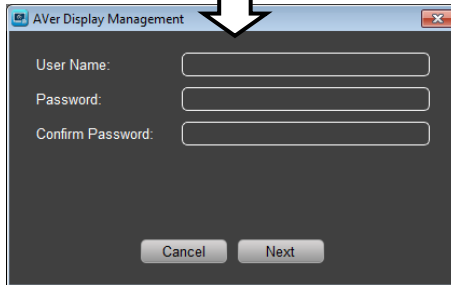
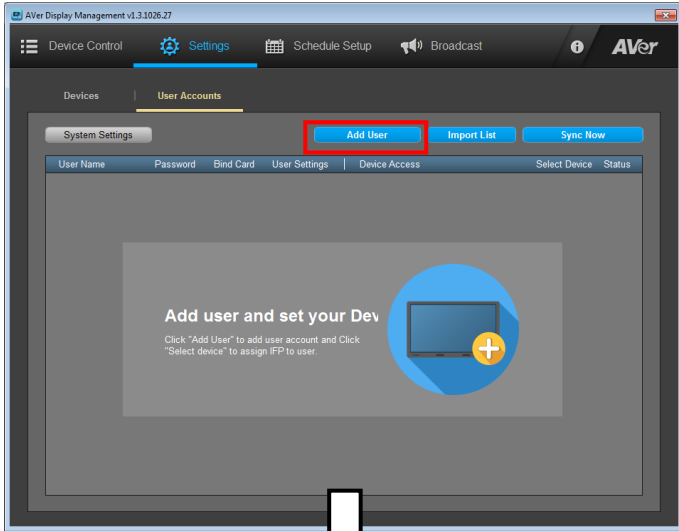

3. Tap the card for login if user wants. If not, select “Skip”.

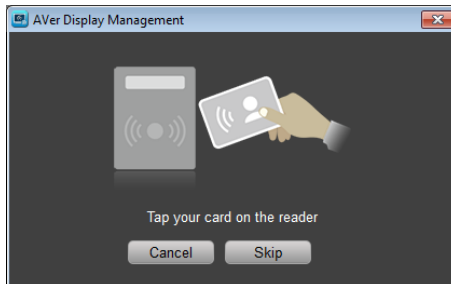

4. Select “Save” and the user account is displayed in list page.

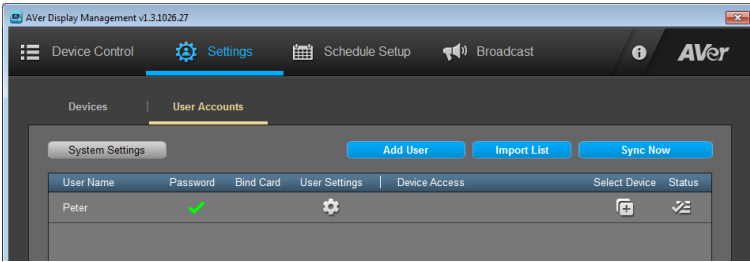

5. **Select Device:** Select the device for synchronization. Select “+” > select device > “Save”.

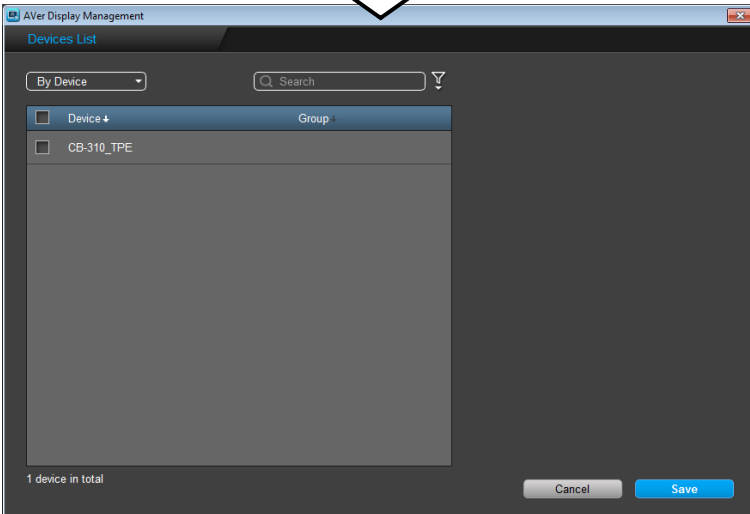
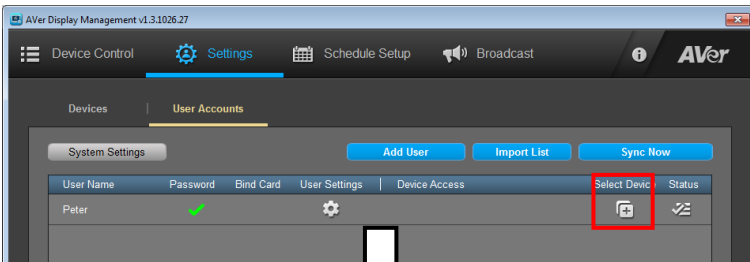

[Note] Search device:

- Select “By Device” and “By Group” to search device.
- Enter keyw ord to search device.
- Select “Device” or “Group” to filter the device.

6. **Permission of Users:** Setup app use and install authority. Select “” > “**Permission of Users**”

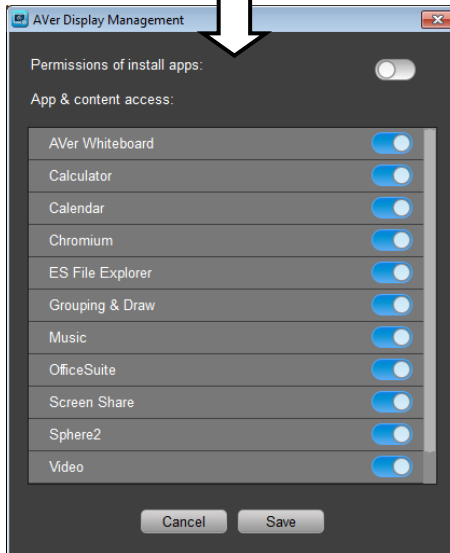
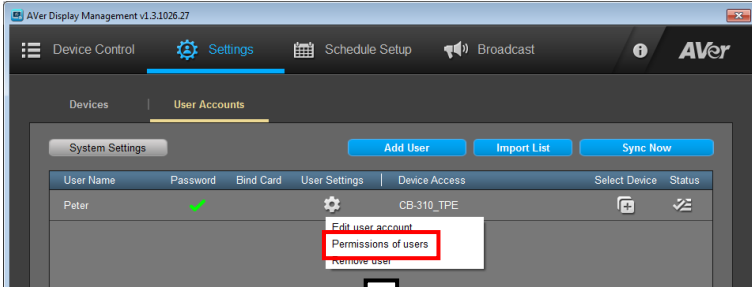

7. Select “**Sync Now**” to synchronize with remote AVer CB-310 device. When synchronize successful, all user accounts are displayed.

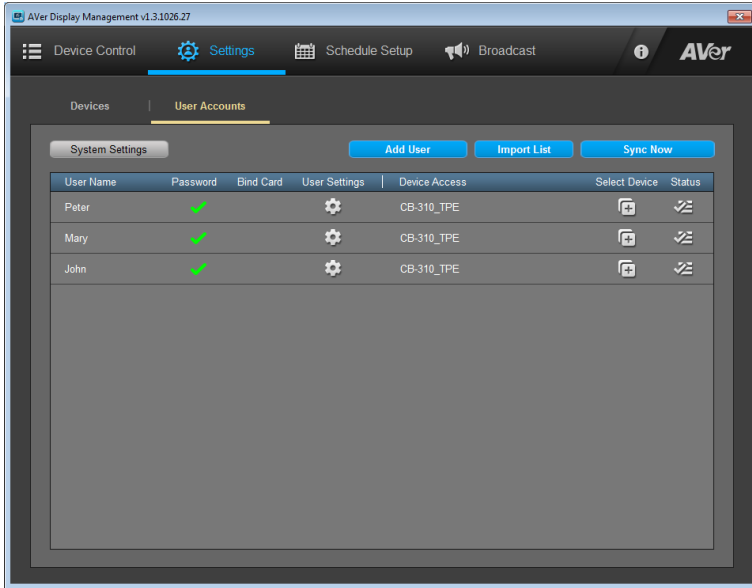

8. Select “” to check synchronize report.

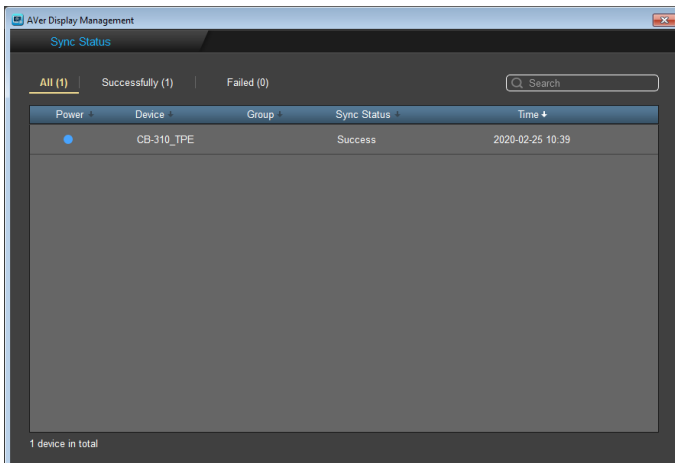

9. Select “” > “**Edit user account**”, user can edit User Name, Password and Bind card login of the user account.

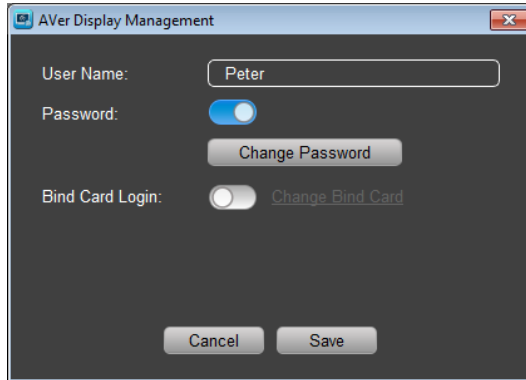

10. Login to AVer CB-310 device, user can see the user accounts has synchronized. Also user can check user accounts in “**Setup**” > “**Multi user**” after login.

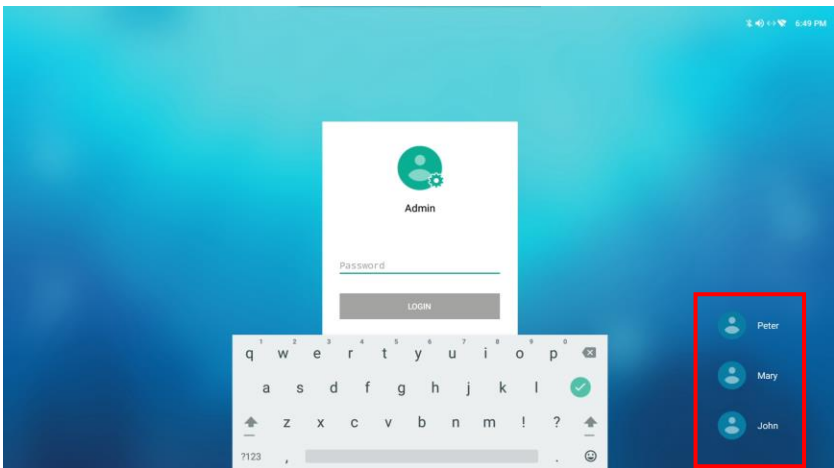

Import List

User can create a user accounts list and use import function to add multiple user accounts.

1. Select “**Import List**” > “**Download a sample file**”. The file format is “*.csv”.

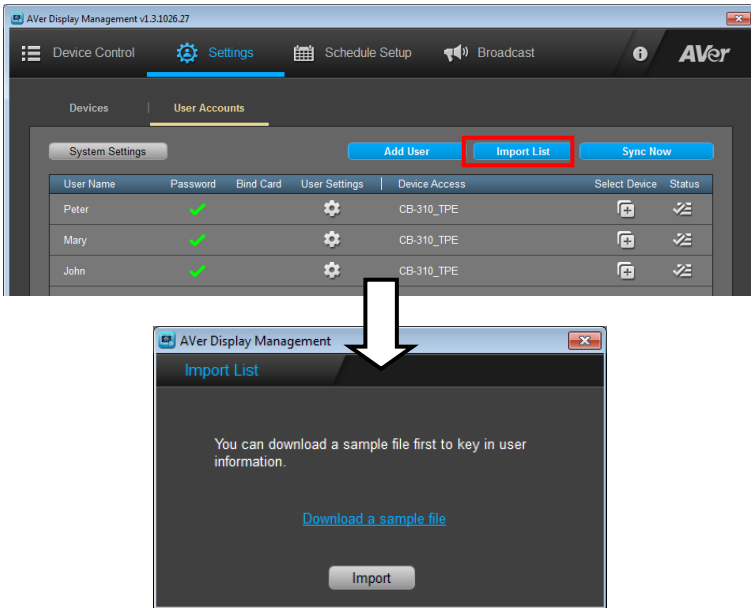

2. Open *.csv file, enter the user accounts and data and save the file.
3. Select “Import List” > “Import”. Then, the user accounts will be added and displayed.

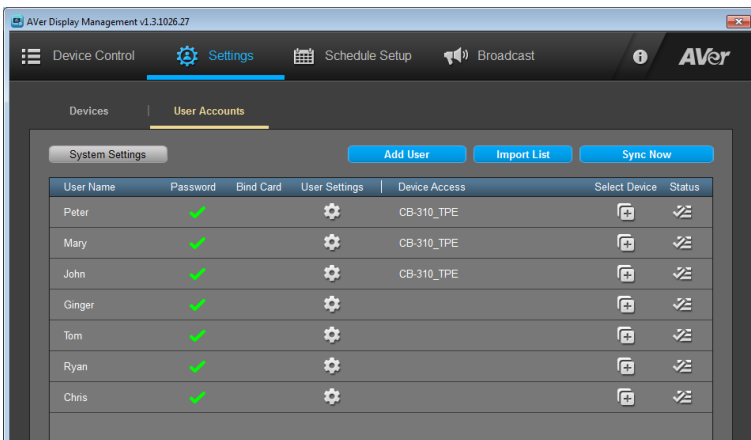

4. **Select Device**: Select the device for synchronization. Select “” > select device > “**Save**”.
5. Select “**Sync Now**” to synchronize with remote AVer CB-310 device. When synchronize successful, all user accounts are displayed.

Specificaion

Android Version	Android 7.1
RAM/ROM	4GB DDR3/ 8GB
CPU	Dual-core ARM Cortex-A72 1.8Ghz processor and Quad-core ARM Cortex-A53 1.4Ghz processor
GPU	ARM Mali-T860MP4
Input /Output (Included resolution)	HDMI input x3 (Max. 1920x1080)
	VGA input x1 (Max. 11920x1080)
	USB-type A x2
	HDMI output x2 (Max. 4K)
USB	USB-type B
Ethernet	Giga-Ethernet
Power	12V/4A; Max. 500mA
Wall Mount	Yes
Warranty	3 years
Operation Environment	Relative Humidity : ≤80 %
	Operation Temperature: 0 ~ +40°C 以上
	Storage Temperature : -10 ~ +60°C
Dimension (without wall mount)	190mm(L) x 154mm(W) x 33mm(H)
Packaging Dimension	305mm(W) x 255mm(D) x 231mm(H)
Net Weight	2.7±0.1 kg

Multimedia Supported Formats

Type	Format	File Extension
Image	JPEG、BMP、PNG	.jpg\.bmp\png
Video	MPEG1、MPEG2、MPEG4、H264、RM、RMVB、MOV、MJPEG、VC1、DivXFLV	.avi\mpg\dat\vob\div\mov\mkv\rm\rmvb\mp4\mpeg\ts\trp\wmv\asf.flv
Audio	MP3、M4A (AAC)	.mp3\m4a

RS-232 Pin Definition

Pin define			
DB9		3.5mm ST	
2	RX	1	RX
3	TX	2	TX
5	GND	3	GND

RS-232 Send Commands Table

Baud Rate: 115200 bps

Data bits: 8 bits

Parity: None

Stop bits: 1 bits

Send Format: Device ID(Default 0x00) + 0x52 + 0x04 + 0x00 + Command + Data[0] + Data[1] + 0x50 + Checksum(*1)

Receive Format: Device ID(Default 0x00) + 0x50 + 0x04 + 0x80(*2) + Command + Data[0] + Data[1] + 0x52 + Checksum(*1)

*1 xor : Exclusive-or operator

*2 Receive Success Check Code : 0x80(Success Command), 0x81(Invalid Command), 0x82(CheckSum Fail)

[Example]

Set Input Source VGA

Send Format: 0x00 + 0x52 + 0x04 + 0x00 + 0x02 + 0x03 + 0x00 + 0x50 + 0x07

Receive Format: 0x00 + 0x50 + 0x04 + 0x80 + 0x02 + 0x03 + 0x00 + 0x52 + 0x87

Function	Command	Data[0]	Data[1]
Power	0x01	0x00: Stand By 0x01: Power On	0x00
Input Source	0x02	0x00: HDMI 0 (Front) 0x01: HDMI 1 0x02: HDMI 2 0x03: VGA 0x04: Type C 0x05: OPS	0x00
Set ID	0x05	0x00: Only one 0x01~0xFF: 1~255	
Wi-Fi	0x30	0x00: Off 0x01: On	0x00
Back to last step	0x35	0x00	0x00
Android HOME	0x37	0x00	0x00

RS-232 Transmission Specifications

Start bit: 1 bit
Data bit : 8 bit
Stop bit : 1 bit
Parity bit : None
X parameter: None
Baud rate (Communication speed) : 115200bps

RS-232 Communication Format

Device ID Code(1 Byte)	0x00	0x00
Receive Device Code(1 Byte)	0x52	0x52
Data Length Code(1 Byte)	0x04	0x04
Type Code(1 Byte)	0x00	0x10
Command Code (1 Byte)	RS-232 Send Command Table	RS-232 Get Command Table
Data[0] Code (1 Byte)	RS-232 Send Command Table	0x00
Data[1] Code (1 Byte)	RS-232 Send Command Table	0x00
Send Device Code (1 Byte)	0x50	0x50
Checksum Code (1 Byte)	XOR	XOR

Format	Device ID + Receive Device + Length + Type + Command + Data[0] + Data[1] + Send Device + CheckSum	
Example	Power On Command: 0x00 + 0x52 + 0x04 + 0x00 + 0x01 + 0x01 + 0x00 + 0x50 + 0x06	Get Input source : 0x00 + 0x52 + 0x04 + 0x10 + 0x02 + 0x00 + 0x00 + 0x50 + 0x14

Troubleshooting

Symptom	Possible Cause	Solution
The screen does not display anything; there is no sound, and the indicator does not come on	Looseness of power plug, power connection failure	Check if the power cord is properly connected
Pictures are colorless	Color saturation is set too low	Enter "Picture" settings to increase the color saturation
The product has no accompanying sound	1. Volume is set too low 2. Sound is muted	1. Adjust the volume to a proper level 2. Press the "MUTE" key on the remote control to unmute the product
The PC does not display anything, and gives a prompt indicating no signal input; the red indicator blinks	Looseness or come-off of the signal connection cable	Check if the signal connection cable is loosened or comes off; if so, reconnect it
Pictures shown on the PC are offset, do not cover the entire screen, go beyond the screen, or are blurred	1. Improper adjustment 2. Wrong display mode	1. Use the auto adjustment function 2. Enter "PC Screen Adjustment" to adjust the horizontal or vertical
Short remote control distance, malfunction of remote control	1. The remote receiver of the product is blocked by some object 2. Battery level of the remote control is low	1. Move the object to avoid blocking the remote receiver 2. Replace the battery
The white noise problem has occurred on screen when MAC computer connect with HDMI in 3840 x 2160 30Hz setting	Might be the compatibility issue	Please change to HDMI 4 connection for normal output

Symptom	Possible Cause	Solution
A link cannot be accessed via the browser	<ol style="list-style-type: none"> 1. Wrong network parameter configuration 2. Improper network connection 3. Network service is not activated 	<ol style="list-style-type: none"> 1. Ask the network administrator for available network IP addresses and other parameters 2. Check if the network connection cable is properly connected 3. Consult the network service provider
Video gets seriously stuck when played online	<ol style="list-style-type: none"> 1. Network bandwidth is low 2. Several movies are buffered or other content is downloaded simultaneously 	<ol style="list-style-type: none"> 1. Upgrade your network bandwidth to a higher one 2. Try replacement with other VOD addresses to obtain better resources
The product gets stuck, crashes or cannot be operated	<ol style="list-style-type: none"> 1. Too many programs are running 2. Normal operation of the product is disturbed by external environment (e.g., lightning, static electricity) 	Disconnect the product from power supply; wait for 1-2min and reconnect power supply; then restart the product
HDMI2 is dedicated to 4K video input, and cannot use the side toolbar and external devices (speakers or microphones).		Please select HDMI Output to output sound when using. Do not use other external devices.