



# AVOCOR E SERIES 55" DISPLAY



The E series 55" display utilizes the very latest optimized touch technology and superior glass technology providing a smooth and extremely accurate, low latency writing experience as well as object recognition. The ability to easily switch between using a pen, finger, and palm create for a fluid collaborative environment for users in real-time and introduces Avocor's UiQ touch enabled interface.



**Avocor UiQ** is Avocor's new Smart touch enabled dynamic user interface, with source preview, touch menu that allows for remote control free usage.



**Over-the-air (OTA) firmware** update capability enables firmware updates to be more efficiently deployed rather than manually upgrading each device individually.

## 55"

Avocor's first ever **55" display** is the perfect size for focus rooms and executive home offices bringing collaboration to smaller spaces.



**Zero parallax glass surface** with anti-glare and anti-fingerprint coating for a crisp image with smooth, pixel-perfect inking.



Enhanced **HDMI out supporting 4k video @60Hz** and offering a range of connectivity options. The 55" display offers a **Type-C connectivity** option and also includes front facing guest HDMI, USB touch connections and a USB hub connection for easy access to USB drive data.



A high-quality, **front-facing soundbar** module is included, ensuring that the display provides 30w conference room audio delivering a crystal-clear audio experience.

## DISPLAY

Diagonal size	55"
Model number	AVE-5530
Backlight	Direct LED
Aspect Ratio	16:9
Resolution	4K@60Hz, 3840 x 2160
Response time	8ms
Brightness (average)	370 (cd/m2)
Contrast ratio(average)	4000:1
Viewing angle°	178° / 178
Supported colors	30-bit deep color
Display orientation	Landscape

## CONNECTIVITY

Guest inputs	1 x HDMI 2.0, 1 x USB-B Touch 3.0, 1 x USB-A 3.0 Hub, 1 x Type-C
Side inputs	2 x HDMI 2.0, 1 x DisplayPort 1.2, 1 x USB-B 3.0 touch, 1 x VGA with audio input, 1 x USB-A 3.0, 1 x USB service port, HDMI Out (4K@60Hz), 1 x LAN Ethernet (RJ-45) out
Audio	1 x 3.5mm audio out, 1 x optical (SPDIF)
Control OPS slot	1 x RS-232, 1 x LAN ethernet (RJ-45) in Yes, 3840 x 2160 @60Hz

## DISPLAY & REMOTE CONTROL FUNCTIONS

Auto-source detection	Yes
Source preview	Yes
Blank	Yes
Freeze	Yes

## TOUCH SYSTEM

Touch	Up to 20 point Avocor Intelligent Touch, supports 1 x fine tip stylus
Glass	2mm optically bonded, anti-glare, anti-fingerprint
Supporting operating system	Windows 8/10, Mac OS*, Linux*

## AUDIO

Built-in speakers	2 x 15W forward facing
-------------------	------------------------

## PHYSICAL SPECIFICATIONS

Product dimensions	1286 x 802 x 78.4 mm   50.63 x 31.57 x 3.09 in
Shipping dimensions	1415 x 932 x 270 mm   55.71 x 36.69 x 10.63 in
Weight	Net: 32.5 kg   71.65 lbs / Gross: 44.5 kg   98.11 lbs
Wall mount VESA	400 x 400 mm   15.75 x 15.75 in
Handles	2

## POWER

Power supply	AC100-240V (Worldwide)50/60Hz
Maximum power consumption	<220W
Standby	≤0.5 W

## ENVIRONMENTAL

Operating temperature	0 °C ~ 40 °C
Storage temperature	-20 °C ~ 60 °C
Humidity	20% ~ 80%

## WHAT'S IN THE BOX

1 x Remote control & batteries, 2 x 3mm fine-tip passive touch pen, AC power cords (1 x UK, 1 x EU, 1 x US, 1 x AUS), 1 x USB-B 3.0 cable (3m | 118.1 inches), 1 x HDMI cable (3m | 118.1 inches), 1 x Quick Start Guide, 1 x Type-C cable (1.5m | 59 inches), 1 x VESA adapter plate

## WARRANTY

Terms and conditions vary via region, please visit [www.avocor.com/faq/avocor-global-warranty](http://www.avocor.com/faq/avocor-global-warranty)

SR598ML3



**Mounting Pattern**  
Up to 800 x 600mm  
(31.50" x 23.62")



**Max Load**  
280lb  
(127kg)

**SMARTMOUNT.**

# Motorized Height Adjustable Flat Panel Cart

FOR 42" TO 86" INTERACTIVE DISPLAYS

The SmartMount® Motorized Height Adjustable Cart was designed to safely mount, move, and store an interactive display. UL recognized actuators allow you to raise or lower a display, up to 25.6" (650mm), with the touch of a button. For easy setup and storage, the rear compartment provides a secure area for a PC and power strip, while the cable management cord wrap neatly stores the power cord when not in use. The cart's large wall plate and locking casters provide a stable foundation for touch applications, and the integrated handles allow you to easily maneuver the cart from room to room. For added protection, the corner bumpers prevent damage to walls or doorways. The durable black powder coat finish provides a nice aesthetic to complement this highly functional solution that is ideal for any touchscreen application.

- Display height can be adjusted up to 25.6" (650mm) with the touch of a button
- Textured black powder coat finish helps hide finger prints and dust
- Open frame display adaptor helps prevent display input interference
- Universal display adaptor fits mounting patterns from 200 x 200 to 800 x 600mm
- Corner bumpers protect walls and doorways from damage
- Rear enclosure provides up to 10"W x 8"H x 4"D storage for mini PCs such as Dell Optiplex Micro, HP 260 G2, Lenovo M600 Tiny or Intel NUC, and also includes mounting locations for external wi-fi antennas
- Safety limit switch automatically reverses direction and stops when a collision is detected in an upward, downward or lateral force
- Includes Peerless-AV® PVP1200-CPL6 six outlet Power Strip with 15ft cord and 2160 joule rating (15A, 120V, 1800W, EMI/RFI noise filtering)
- Cord wrap included for managing surge protector cord
- UL 962 listed, complementary UL1678 listing



**PLUMB ADJUSTMENT**  
+2° / -4° of plumb adjustment keeps even the heaviest of displays level

**VERTICAL ADJUSTMENT**  
Center of display is adjustable from 34"-60" from the floor

**WELDED BASE AND PRE-ASSEMBLED CASTERS**  
Provide rigidity, stability and quick assembly

**SAFE AND EASY MANEUVERABILITY**  
4" (102mm) swivel casters meet UL/CUL requirements



Rear Enclosure with Included Six Outlet Surge Protector (PVP1200-CPL6)



**RoHS**  
2002/95/EC



Complies with the ADA Standards for Accessible Design, Section 308.

✉ info@peerless-av.com

🌐 peerless-av.com

**peerless-AV®**  
Driving Technology Through Innovation

SR598ML3 SmartMount® Motorized Height Adjustable Flat Panel Cart for 42" to 86" Interactive Displays

**Product Specifications**

	DIMENSIONS (W X H X D)	PRODUCT WEIGHT	LOAD CAPACITY	FINISH	AVAILABLE COLORS
SR598ML3	46.60" x 47.33"-72.87" x 30.70" (1184 x 1202-1851 x 780mm)	115lb (52.2kg)	280lb (127kg) Display	Textured Powder Coat	Black

**Package Specifications**

	PACKAGE SIZE (W x H x D)	PACKAGE SHIP WEIGHT	PACKAGE UPC CODE	PACKAGE CONTENTS	UNITS IN PACKAGE
SR598ML3	48.00" x 10.00" x 39.00" (1219 x 254 x 991mm)	130.5lb (59.2kg)	735029322108	Assembled Base with Motorized Columns and Casters, Rear Enclosure, Universal Display Adaptor, Control Box, Control Switch, Surge Protector, Hardware & Instructions	1

**Accessories**

- ACC310:** Feet Accessory
- ACC-MCCM:** Component Mount
- ACC-WMVCS:** Video Conferencing Shelf

All dimensions = inch (mm)

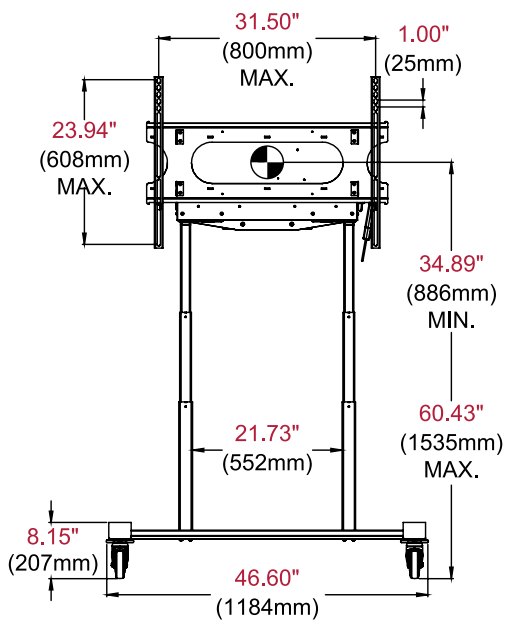

**FRONT VIEW**

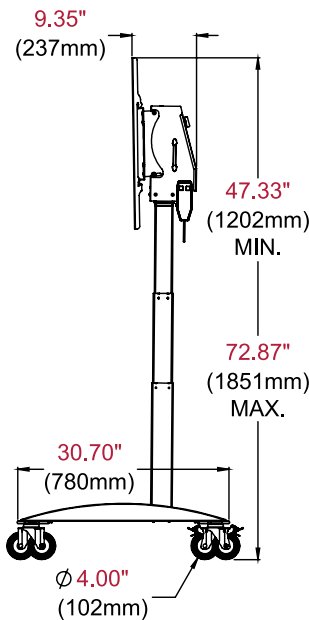

**SIDE VIEW**

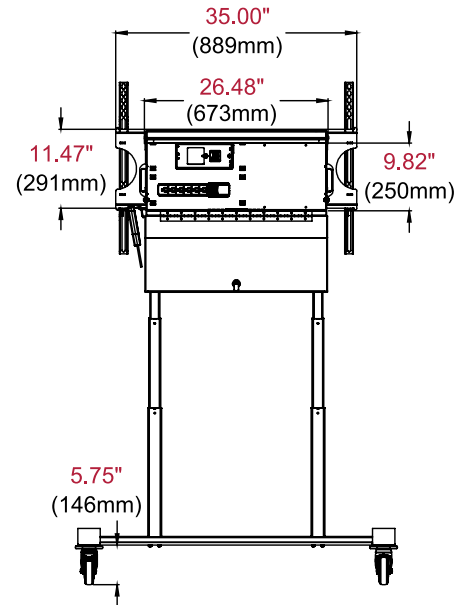

**BACK VIEW**

**Architect Specifications**

The SmartMount® Motorized Height Adjustable Flat Panel Cart shall be a Peerless-AV model SR598ML3 and shall be located where indicated on the plans. Assembly and installation shall be done according to instructions provided by the manufacturer.

Visit [peerless-av.com](http://peerless-av.com) to see the complete line of AV solutions from Peerless-AV, including outdoor displays, wireless, kiosks, digital audio, display mounts, projector mounts, carts/stands, and a full assortment of accessories.

**Peerless-AV**  
2300 White Oak Circle  
Aurora, IL 60502 USA  
  
**(800) 865-2112**  
**(630) 375-5100**  
**Fax: (800) 359-6500**

**Peerless-AV EMEA**  
Unit 3 Watford Interchange  
Colonial Way, Watford  
Herts, WD24 4WP  
United Kingdom  
**+44 (0) 1923 200100**  
**Fax: +44 (0) 1923 200101**

**Peerless-AV Latin America**  
Av. de las Industrias 413  
Parque Industrial Escobedo  
General Escobedo, N.L.,  
México, 66062  
**+52 (81) 8384-8300**  
**Fax: +52 (81) 8384-8360**

