

Product Dimensions:

Compatible with:

- BalanceBox®400
- BalanceBox®400H

Compatibility with BalanceBox®tilt is limited, please refer to our product warnings sheet.

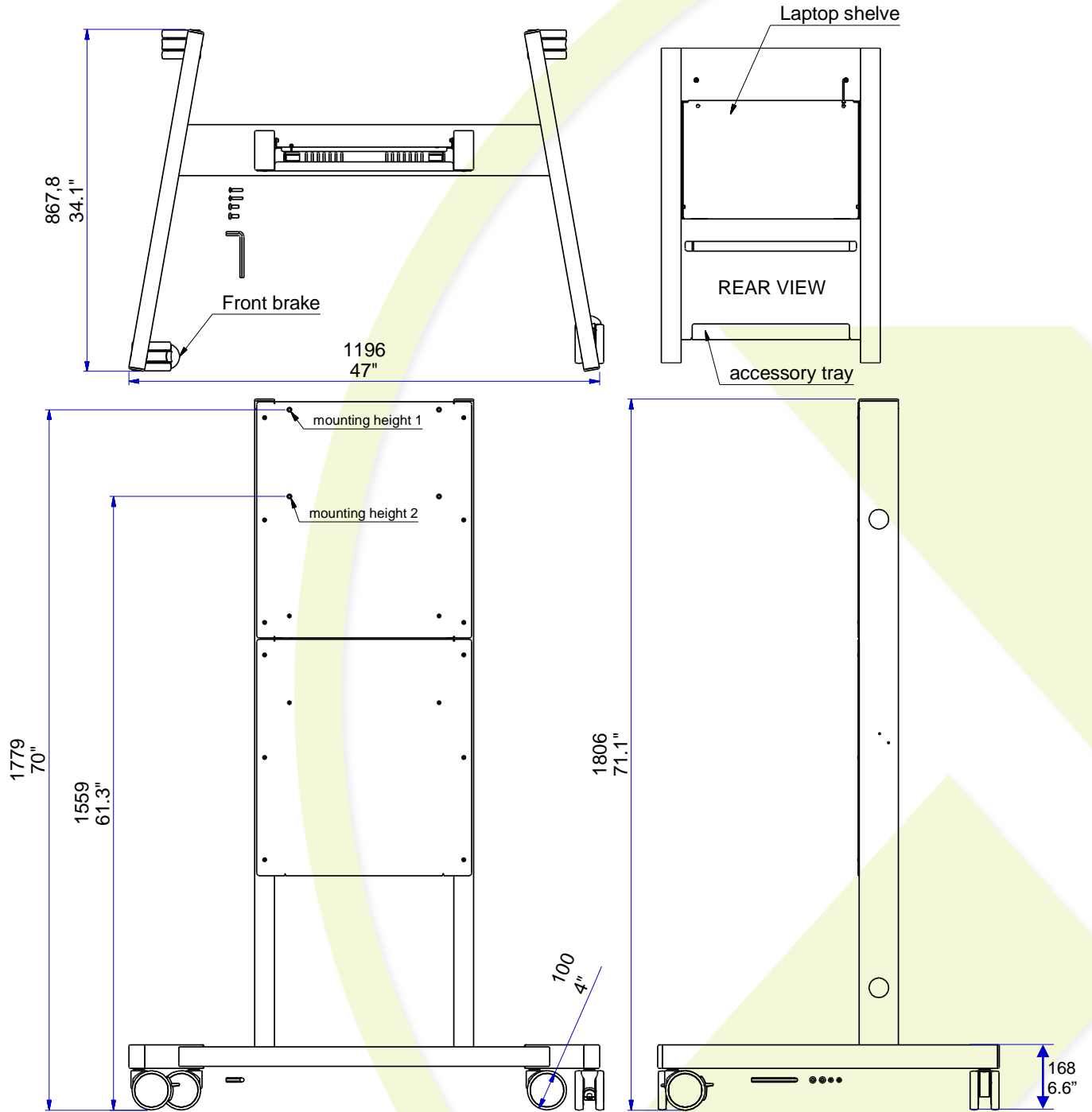

Rev.01

Mobile stand LWB

For the BalanceBox®400

Product datasheet

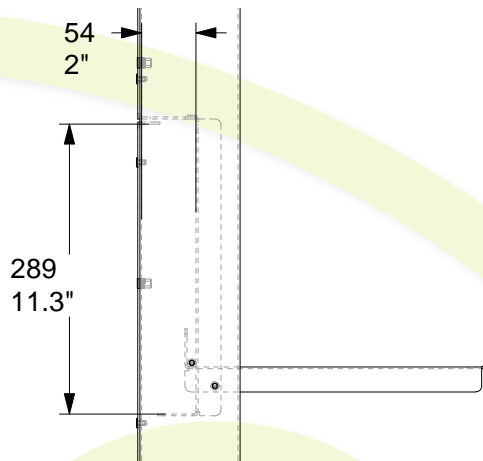

Integrated laptop shelf, can be closed with a padlock in up position (padlock not included) for mini computer or laptop.

Product Specifications 481A47002 Mobile stand for BalanceBox® 400				Shipping dimensions				
	metric		US / imperial		metric		US / imperial	
	value	units	value	units	value	units	value	units
Length	1806 mm		71.1 inch		1800 mm		70.8 inch	
Width	1196 mm		47 inch		900 mm		35.4 inch	
Depth	868 mm		34.1 inch		180 mm		7 inch	
Weight					47 kg		103.4 lbs	
Wheel diameter	100 mm		4 inch					
Load capacity	125 Kg		275 Lbs					
Material	Steel frame							
Finish	Powder coated in colour: Black RAL9005							

- For BalanceBox 400 for touchpanels 55" to 86" (maximum 90 kg / 198 lbs)
- Use only with BalanceBox accessories or approved 3rd party accessories
- 50mm / 2" holes in frame for cable ducting
- Integrated laptop shelf doubles as lockable mini computer or laptop enclosure (padlock not included)
- 100 mm / 4" black nylon wheels with non marking PU tires
- Product certification: CE and UL Recognized
- (UL 60950-1, Information Technology Equipment - Safety -Part 1: General Requirements, CAN/CSA C22.2 No. 60950-1-07, Information Technology Equipment - Safety - Part 1:General Requirements)