

Industrial Grade Powered Lift Column With Integrated Dampening

Optional White Finish Shown

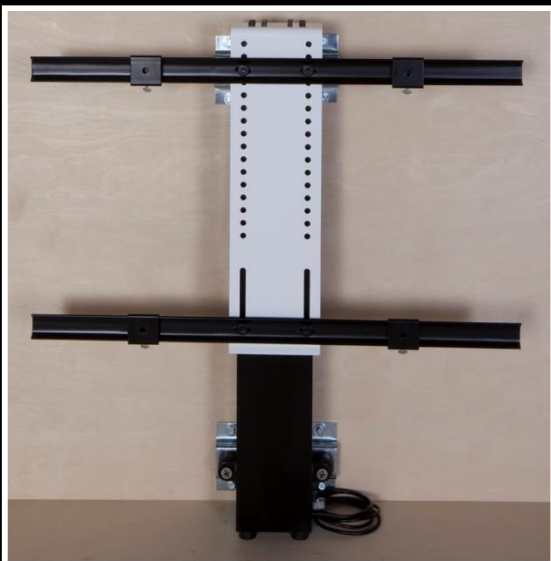

FEATURES

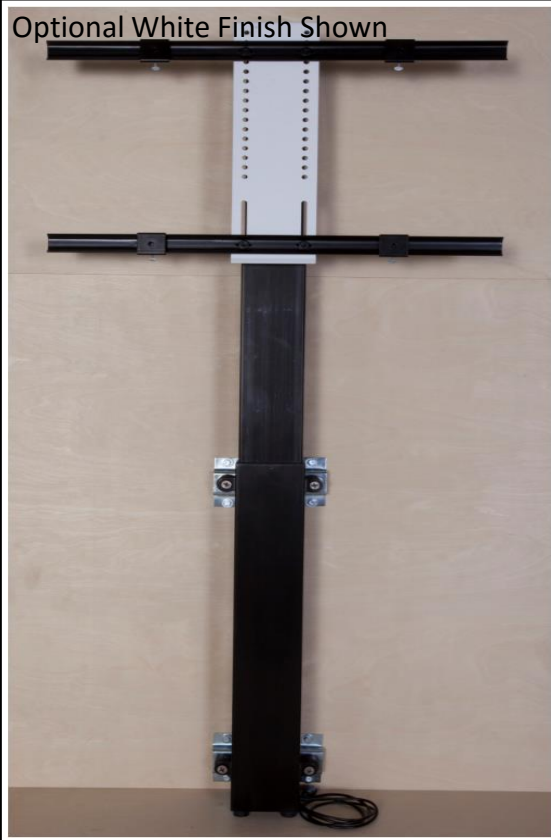
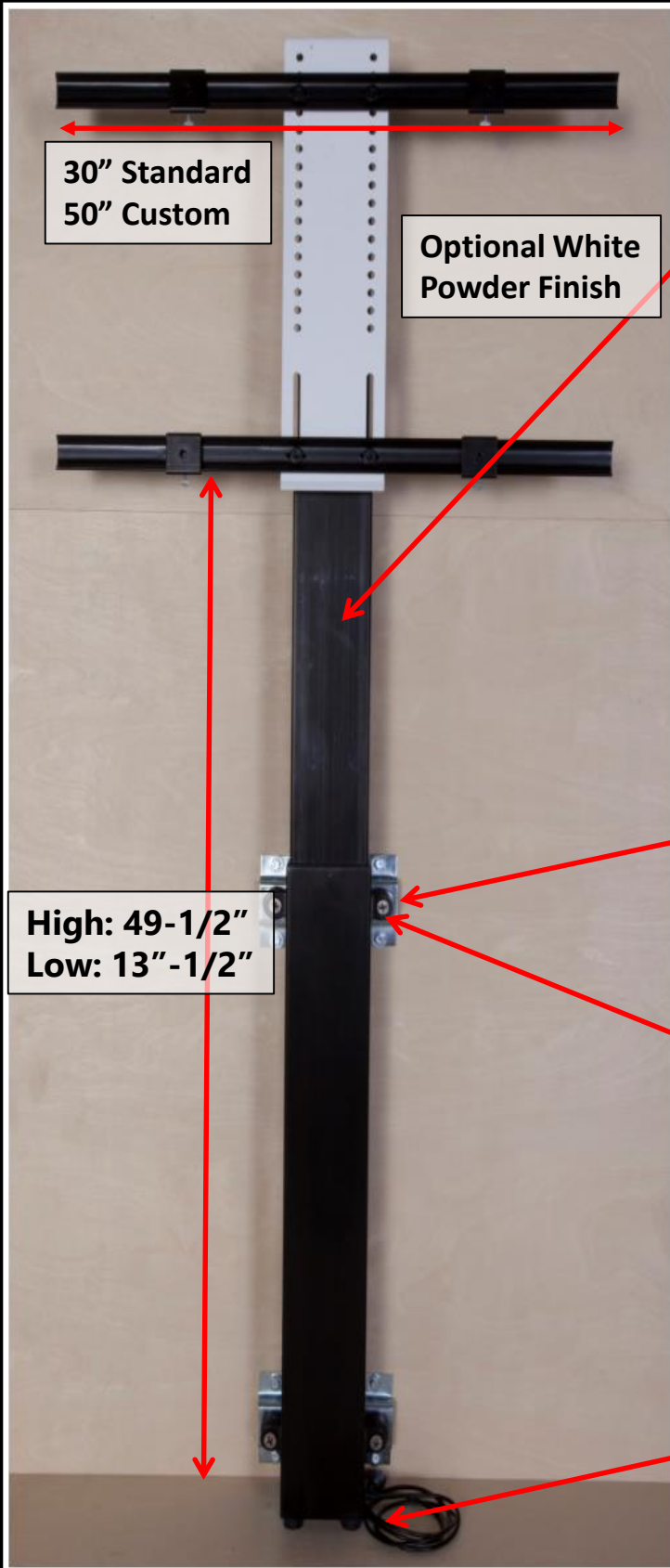

36" Vertical Travel

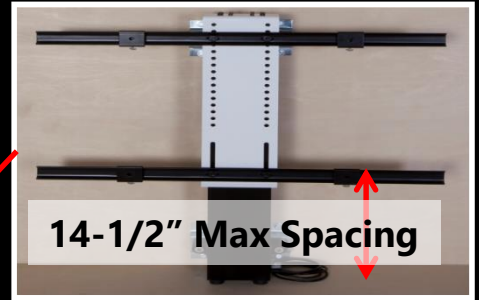

(4) Point Cross Rail Dampening

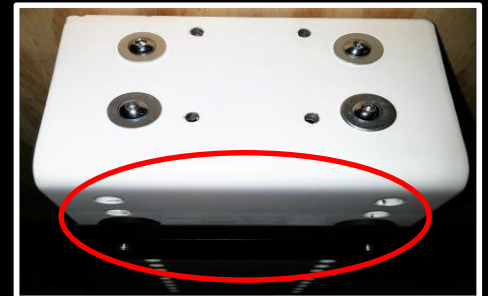

(4) Point, Adjustable Tension, Omni-Directional Shock Resistant Wall Brackets



(4) Point Column Connection Dampening



(4) Point Base Dampening



Lift Column



Note: dimensions do not include wall dampeners.

Standard Dimensions (mm)

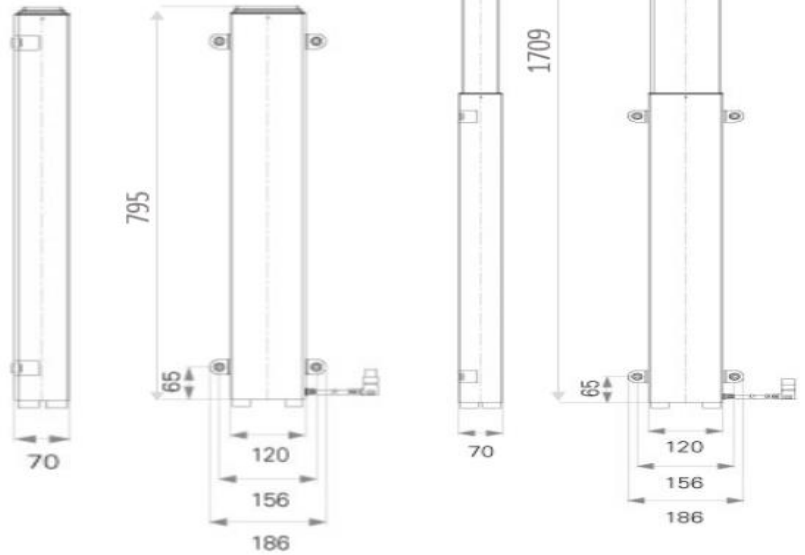

Control Box

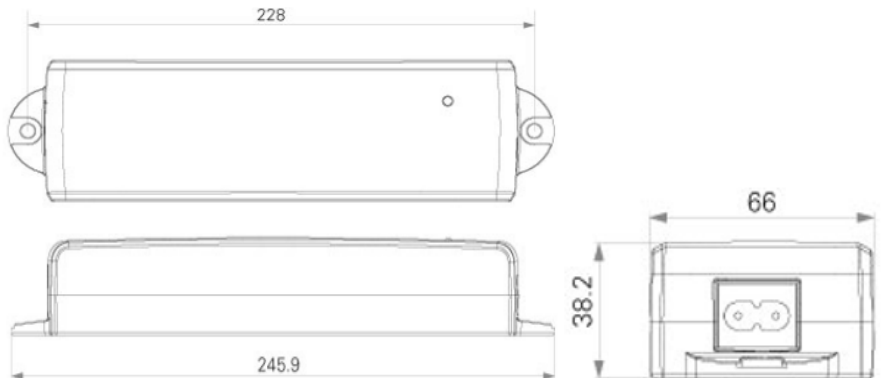

Wired Hand Controller



General Features

Maximum Load: 135lbs
 VESA: 100x100mm-600x400mm
 Max Speed at Full Load: .866"/sec
 Certificate: RoHS 

Vertical Travel: 36"
 Column Height: 48.1"
 Max Screen Size: 65"

Limited Warranty: 5yrs. on Column, 2yrs. On Control Box and Hand Controller. The Limited Warranty covers manufacturing defects in the products from date of production. Improper operation, installation, over-spec applications, function failure caused by other assembled products, unexpected natural calamity or aggressive use is not covered. Further Warranty details provided in Assembly Manual. The product is not approved For Sale outside of the USA.