

Product Dimensions:

- Compatible with:**
- BalanceBox® 400
- BalanceBox® 400H

Compatibility with BalanceBox® tilt is limited, please refer to our product warnings sheet.

www.balancebox.eu

For Touchscreen and Interactive whiteboard applications.

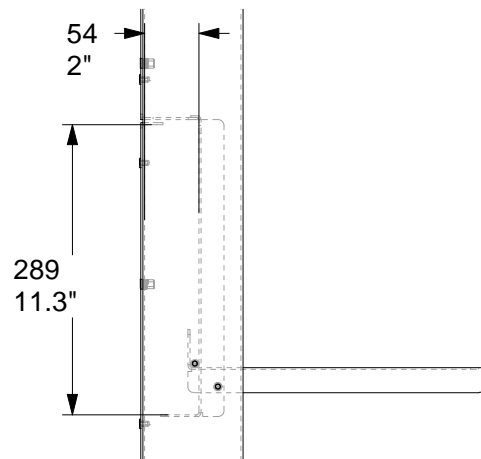
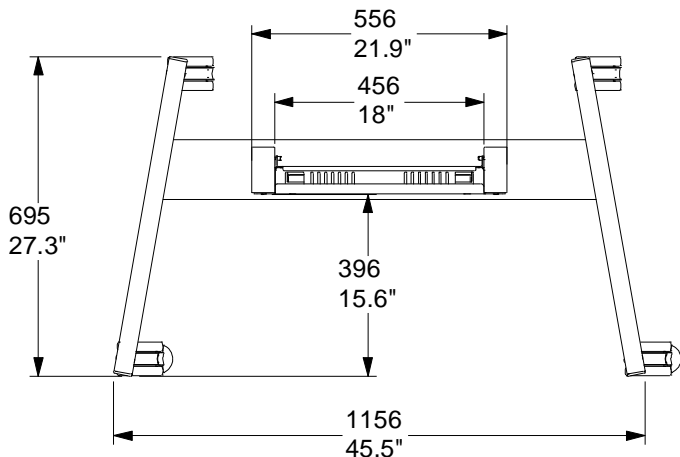

Integrated laptop shelf, can be closed with a padlock in up position (padlock not included) for mini computer or laptop.

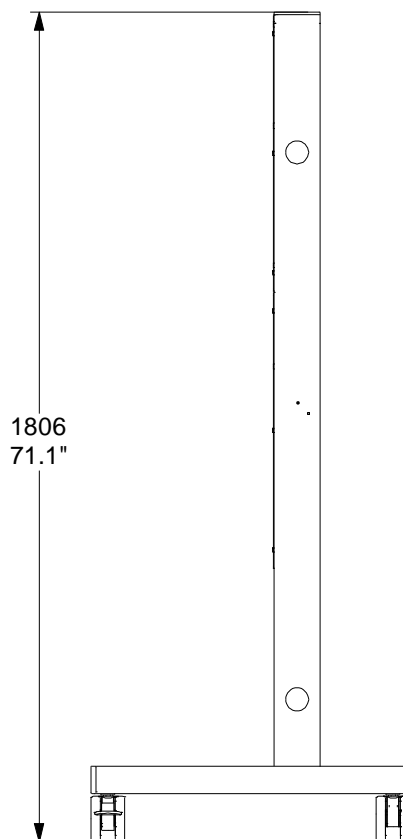
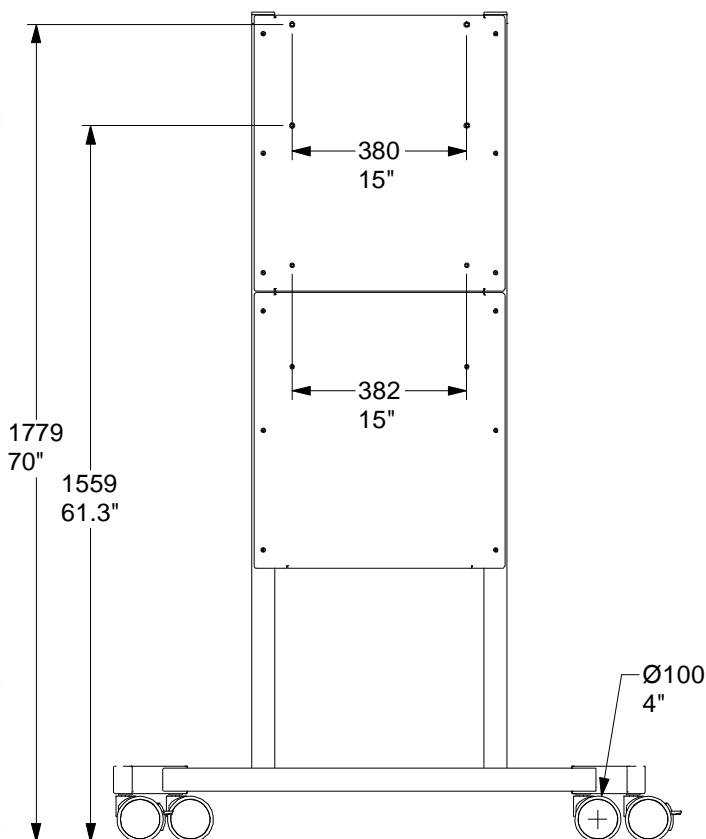

V:20160921





Mobile stand for the BalanceBox® 400

	Product Specifications 481A31002 Mobile stand for BalanceBox® 400				Shipping dimensions			
	metric		US / imperial		metric		US / imperial	
	value	units	value	units	value	units	value	units
Length	1806	mm	71	inch	1800	mm	70.8	inch
Width	1156	mm	45.5	inch	720	mm	28.3	inch
Depth	695	mm	27.3	inch	180	mm	7	inch
					45	kg	99	lbs
Load capacity	125	kg	209	lbs				
Wheels diam.	100	mm	4	inch				
Material	Steel frame							
Finish	Powder coated in colour: Black RAL9005							

- For BalanceBox 400 and 400H for touchscreen and Interactive whiteboard applications.
- Use only with BalanceBox® accessories
- Use with BalanceBox® Tilt is limited, please refer to our warnings datasheet
- 50mm / 2" holes in frame for cable ducting
- Integrated laptop shelf doubles as lockable mini computer or laptop enclosure (padlock not included)
- 100 mm / 4" black nylon wheels with non marking PU tires