



GasAlertMicro5 Series

Multi-Gas (1-5) Detectors

VOCs, CO₂, LEL, H₂S, CO, O₂, SO₂, PH₃, NH₃, NO₂, HCN, Cl₂, ClO₂, O₃



GasAlertMicro 5.....	50
GasAlertMicro 5 PID.....	52
GasAlertMicro 5 IR.....	54
GasAlertMicro 5 Series Accessories, Spares & Replacements	56
GasAlertMicro 5 Series Service Parts	60

Protect yourself

Compact and lightweight, GasAlertMicro 5 Series instruments are available in diffusion or pumped instruments. The portable gas detectors simultaneously monitors and displays up to five potential atmospheric hazards. The GasAlertMicro 5 PID model also identifies PID detectable VOCs, while the GasAlertMicro 5 IR uses an NDIR sensor to monitor CO₂ levels. Adaptable to a variety of applications, GasAlertMicro 5 Series instruments have an extensive selection of user-settable field options. Use the passcode function to prevent unauthorized modifications of the instrument's settings. Compatible with BW's MicroDock II automatic test and calibration system, GasAlertMicro 5 Series instruments are unparalleled in their versatility, performance and overall value.

Standard Package Contents

- Detector complete with specified sensor(s), stainless steel alligator clip and concussion-proof housing
- Rechargeable battery pack or alkaline pack with three AA batteries
- Cradle charger and wall outlet charging adaptor (with rechargeable battery option)
- Sample probe (with motorized pump option)
- Screwdriver
- Calibration/test adaptor and hose
- Manual
- Multi-language CD manual

General Specifications

Size	5.7 x 2.9 x 1.5 in. / 14.5 x 7.4 x 3.8 cm
Weight	13.1 oz. / 370 g
Operating temperature	-4 to +122°F / -20 to +50°C 14 to +104°F / -10 to +40°C (PID)
Typical battery life	20 hours (15 hours PID/IR)* <i>*Based on a 5-gas instrument in diffusion mode at 68°F / 20°C</i>

Certifications and approvals



Class I, Div. 1, Gr. A, B, C, D



American Bureau of Shipping
(Toxic and PID models)

ATEX:

CE Ex II 1 G

Ga Ex ia IIC T4*

CE Ex II 2 G (IR model only)

Ex d ia IIC T4*

IECEX:

Ga Ex ia IIC T4*

Ex d ia IIC T4* (IR model only)

**Temperature codes may vary as a function of the batteries installed.*

Please see owner's manual for a complete listing of compatible batteries and codes.

Warranty

Full two year warranty including sensors
(one year Cl₂, NH₃, O₃, ClO₂ and PID sensor)



GasAlertMicro 5 Series (continued)

GasAlertMicro 5 Detector

Order Number

%LEL, O ₂ , H ₂ S, CO, SO ₂ - rechargeable battery, yellow housing	M5-XWSY-R-D-D-Y-N-00
%LEL, O ₂ , H ₂ S, CO, SO ₂ - rechargeable battery and pump, yellow housing	M5-XWSY-R-P-D-Y-N-00
%LEL, O ₂ , H ₂ S, CO, NH ₃ - rechargeable battery, yellow housing	M5-XWAY-R-D-D-Y-N-00
%LEL, O ₂ , H ₂ S, CO, NH ₃ - rechargeable battery and pump, yellow housing	M5-XWAY-R-P-D-Y-N-00
%LEL, O ₂ , H ₂ S, CO, Cl ₂ - rechargeable battery, yellow housing	M5-XWCY-R-D-D-Y-N-00
%LEL, O ₂ , H ₂ S, CO, Cl ₂ - rechargeable battery and pump, yellow housing	M5-XWCY-R-P-D-Y-N-00
%LEL, O ₂ , H ₂ S, CO - alkaline batteries and pump, yellow housing	M5-XW0Y-A-P-D-Y-N-00
%LEL, O ₂ , H ₂ S, CO - rechargeable battery, yellow housing	M5-XW0Y-R-D-D-Y-N-00
%LEL, O ₂ , H ₂ S, CO - rechargeable battery and pump, yellow housing	M5-XW0Y-R-P-D-Y-N-00
%LEL, O ₂ , H ₂ S, CO, SO ₂ - rechargeable battery, black housing	M5-XWSY-R-D-D-B-N-00
%LEL, O ₂ , H ₂ S, CO, SO ₂ - rechargeable battery and pump, black housing	M5-XWSY-R-P-D-B-N-00
%LEL, O ₂ , H ₂ S, CO, NH ₃ - rechargeable battery, black housing	M5-XWAY-R-D-D-B-N-00
%LEL, O ₂ , H ₂ S, CO, NH ₃ - rechargeable battery and pump, black housing	M5-XWAY-R-P-D-B-N-00
%LEL, O ₂ , H ₂ S, CO, Cl ₂ - rechargeable battery, black housing	M5-XWCY-R-D-D-B-N-00
%LEL, O ₂ , H ₂ S, CO, Cl ₂ - rechargeable battery and pump, black housing	M5-XWCY-R-P-D-B-N-00
%LEL, O ₂ , H ₂ S, CO - alkaline batteries and pump, black housing	M5-XW0Y-A-P-D-B-N-00
%LEL, O ₂ , H ₂ S, CO - rechargeable battery, black housing	M5-XW0Y-R-D-D-B-N-00
%LEL, O ₂ , H ₂ S, CO - rechargeable battery and pump, black housing	M5-XW0Y-R-P-D-B-N-00

GasAlertMicro 5 Region Codes

For orders outside North America, change order number component “-N” to:

“-E” Europe	“-B” Brazil
“-U” United Kingdom	“-X” Other region with 3-pin UK plug
“-A” Australia	“-Y” Other region with 2-pin UK plug
“-C” China/New Zealand	

Note: Listed above are commonly ordered instrument configurations. To create a custom GasAlertMicro 5 detector, use the configurator table on the next page or contact BW Technologies for a copy of the electronic order number configurator.

Gas Legend

%LEL	Combustible (W)	ClO ₂	Chlorine dioxide (V)
O ₂	Oxygen (X)	NH ₃	Ammonia (A)
H ₂ S	Hydrogen sulfide (H)	PH ₃	Phosphine (P)
CO	Carbon monoxide (M)	HCN	Hydrogen cyanide (Z)
SO ₂	Sulfur dioxide (S)	NO ₂	Nitrogen dioxide (D)
Cl ₂	Chlorine (C)	O ₃	Ozone (G)



GasAlertMicro 5
Diffusion version



GasAlertMicro 5
Pump version

GasAlertMicro 5 Series (continued)

GasAlertMicro 5 Order Number Configurator

► Sensor - Toxic 2 None (dummy sensor) 0 CO and H ₂ S (Duo-Tox dual channel) Y H ₂ S (hydrogen sulfide) H CO (carbon monoxide) M Cl ₂ (chlorine) C ClO ₂ (chlorine dioxide) V PH ₃ (phosphine) P HCN (hydrogen cyanide) Z NO ₂ (nitrogen dioxide) D O ₃ (ozone) G		► Battery A Alkaline R Rechargeable battery pack and cradle charger	
► Sensor - Toxic 1 None (dummy sensor) 0 H ₂ S (hydrogen sulfide) H CO (carbon monoxide) M SO ₂ (sulfur dioxide)* S* Cl ₂ (chlorine) C ClO ₂ (chlorine dioxide) V NH ₃ (ammonia)* A* PH ₃ (phosphine) P HCN (hydrogen cyanide) [†] Z [†] NO ₂ (nitrogen dioxide) D O ₃ (ozone) G		► Sampling D Diffusion P Motorized sampling pump	
► Sensor - Combustible Gases None (dummy sensor) 0 %LEL (combustibles) W		► Datalogging D Datalogging monitor (with Fleet Manager II software)	
► Sensor - Oxygen None 0 O ₂ (oxygen) X		► Housing Y Yellow housing B Black housing	
► Base Unit Base unit M5		► Region N North America E Europe C China/New Zealand U United Kingdom A Australia B Brazil X Other region with 3-pin UK plug Y Other region with 2-pin EU plug	

Order number: M5 D 00

For example, the order number for a GasAlertMicro 5 configured for O₂, %LEL, Cl₂, H₂S and CO and equipped with a rechargeable battery pack and cradle charger, motorized sampling pump, yellow housing and North American power connectivity would be M5-WWCY-R-P-D-Y-N-00.

*Note: Some gases (e.g. SO₂ and NH₃) cannot be combined in the same GasAlertMicro 5 configuration. Please check with Customer Service for specific availability.

[†]Note: HCN can only be ordered in the Toxic 1 location when the Duo-Tox (CO/H₂S) sensor is ordered in the Toxic 2 location. In all other configurations, HCN must be ordered in the Toxic 2 location.

USA 1.888.749.8878
 Canada 1.800.663.4164
 Latin & South America +55.11.3309.1030

Europe +41 (0) 44.943.4300
 Germany +49 (0) 2137.17.6522
 France +33 (0) 442.98.17.70
 Middle East +971.4.4505852

China +86.10.6786.7305
 S.E. Asia +65.6580.3468
 Australia +1.300.729.450
 Other Countries +1.403.248.9226



GasAlertMicro 5 Series (continued)

GasAlertMicro 5 PID Detector

Order Number

VOCs, %LEL, O ₂ , H ₂ S, CO - alkaline batteries and pump, yellow housing	M5PID-XWQY-A-P-D-Y-N-00
VOCs, %LEL, O ₂ , H ₂ S, CO - rechargeable battery and pump, yellow housing	M5PID-XWQY-R-P-D-Y-N-00
VOCs, %LEL, O ₂ - alkaline batteries and pump, yellow housing	M5PID-XWQ0-A-P-D-Y-N-00
VOCs, %LEL, O ₂ - rechargeable battery and pump, yellow housing	M5PID-XWQ0-R-P-D-Y-N-00
VOCs - alkaline batteries and pump, yellow housing	M5PID-00Q0-A-P-D-Y-N-00
VOCs - rechargeable battery and pump, yellow housing	M5PID-00Q0-R-P-D-Y-N-00
VOCs, %LEL, O ₂ , H ₂ S, CO - alkaline batteries and pump, black housing	M5PID-XWQY-A-P-D-B-N-00
VOCs, %LEL, O ₂ , H ₂ S, CO - rechargeable battery and pump, black housing	M5PID-XWQY-R-P-D-B-N-00
VOCs, %LEL, O ₂ - alkaline batteries and pump, black housing	M5PID-XWQ0-A-P-D-B-N-00
VOCs, %LEL, O ₂ - rechargeable battery and pump, black housing	M5PID-XWQ0-R-P-D-B-N-00
VOCs - alkaline batteries and pump, black housing	M5PID-00Q0-A-P-D-B-N-00
VOCs - rechargeable battery and pump, black housing	M5PID-00Q0-R-P-D-B-N-00

GasAlertMicro 5 PID Region Codes

For orders outside North America, change order number component “-N” to:

“-E” Europe	“-B” Brazil
“-U” United Kingdom	“-X” Other region with 3-pin UK plug
“-A” Australia	“-Y” Other region with 2-pin UK plug
“-C” China/New Zealand	

Note: Listed above are commonly ordered instrument configurations. To create a custom GasAlertMicro 5 PID detector, use the configurator table on the next page or contact BW Technologies for a copy of the electronic order number configurator.

Gas Legend

%LEL	Combustible (W)	ClO ₂	Chlorine dioxide (V)
O ₂	Oxygen (X)	NH ₃	Ammonia (A)
H ₂ S	Hydrogen sulfide (H)	PH ₃	Phosphine (P)
CO	Carbon monoxide (M)	HCN	Hydrogen cyanide (Z)
SO ₂	Sulfur dioxide (S)	NO ₂	Nitrogen dioxide (D)
Cl ₂	Chlorine (C)	O ₃	Ozone (G)
VOCs	Volatile organic compounds (Q)		



GasAlertMicro 5 PID
Diffusion version

GasAlertMicro 5 PID
Pump version

GasAlertMicro 5 Series (continued)

GasAlertMicro 5 PID Order Number Configurator

► Sensor - Toxic 2		► Battery	
None (dummy sensor)	0	A	Alkaline
CO and H ₂ S (Duo-Tox dual channel)	Y	R	Rechargeable battery pack and cradle charger
H ₂ S (hydrogen sulfide)	H	► Sampling	
CO (carbon monoxide)	M	D	Diffusion
SO ₂ (sulfur dioxide)	S	P	Motorized sampling pump
Cl ₂ (chlorine)	C	► Datalogging	
ClO ₂ (chlorine dioxide)	V	D	Datalogging monitor (with Fleet Manager II software)
NH ₃ (ammonia)	A	► Housing	
PH ₃ (phosphine)	P	Y	Yellow housing
HCN (hydrogen cyanide)	Z	B	Black housing
NO ₂ (nitrogen dioxide)	D	► Region	
O ₃ (ozone)	G	N	North America
► Sensor - Toxic 1		E	Europe
None (dummy sensor)	0	C	China/New Zealand
PID (photoionization detector) for VOCs (volatile organic compounds)	Q	U	United Kingdom
► Sensor - Combustible Gases		A	Australia
None (dummy sensor)	0	B	Brazil
%LEL (combustibles)	W	X	Other region with 3-pin UK plug
► Sensor - Oxygen		Y	Other region with 2-pin EU plug
None	0		
O ₂ (oxygen)	X		
► Base Unit			
Base unit	M5PID		

Order number:	M5PID						D			00
---------------	-------	--	--	--	--	--	---	--	--	----

For example, the order number for a GasAlertMicro 5 PID configured for O₂, %LEL, VOCs, H₂S and CO and equipped with a rechargeable battery pack and cradle charger, motorized sampling pump, yellow housing and North American power connectivity would be M5PID-XWQY-R-P-D-Y-N-00.

*Note: Some gases cannot be combined in the same GasAlertMicro 5 configuration. Please check with Customer Service for specific availability.

USA 1.888.749.8878
 Canada 1.800.663.4164
 Latin & South America +55.11.3309.1030

Europe +41 (0) 44.943.4300
 Germany +49 (0) 2137.17.6522
 France +33 (0) 442.98.17.70
 Middle East +971.4.4505852

China +86.10.6786.7305
 S.E. Asia +65.6580.3468
 Australia +1.300.729.450
 Other Countries +1.403.248.9226

BWF
 Technologies
 by Honeywell

GasAlertMicro 5 Series (continued)

GasAlertMicro 5 IR Detector

Order Number

CO ₂ (IR), %LEL, O ₂ , H ₂ S, CO - rechargeable battery, yellow housing	M5IR-XWBY-R-D-D-Y-N-00
CO ₂ (IR), %LEL, O ₂ , H ₂ S, CO - rechargeable battery and pump, yellow housing	M5IR-XWBY-R-P-D-D-Y-N-00
CO ₂ (IR), %LEL, O ₂ , H ₂ S - rechargeable battery, yellow housing	M5IR-XWBH-R-D-D-Y-N-00
CO ₂ (IR), %LEL, O ₂ , H ₂ S - rechargeable battery and pump, yellow housing	M5IR-XWBH-R-P-D-D-Y-N-00
CO ₂ (IR), %LEL, O ₂ - rechargeable battery, yellow housing	M5IR-XWB0-R-D-D-Y-N-00
CO ₂ (IR), %LEL, O ₂ - rechargeable battery and pump, yellow housing	M5IR-XWB0-R-P-D-D-Y-N-00
CO ₂ (IR) - rechargeable battery, yellow housing	M5IR-00B0-R-D-D-Y-N-00
CO ₂ (IR) - rechargeable battery and pump, yellow housing	M5IR-00B0-R-P-D-D-Y-N-00
CO ₂ (IR), %LEL, O ₂ , H ₂ S, CO - rechargeable battery, black housing	M5IR-XWBY-R-D-D-B-N-00
CO ₂ (IR), %LEL, O ₂ , H ₂ S, CO - rechargeable battery and pump, black housing	M5IR-XWBY-R-P-D-D-B-N-00
CO ₂ (IR), %LEL, O ₂ , H ₂ S - rechargeable battery, black housing	M5IR-XWBH-R-D-D-B-N-00
CO ₂ (IR), %LEL, O ₂ , H ₂ S - rechargeable battery and pump, black housing	M5IR-XWBH-R-P-D-D-B-N-00
CO ₂ (IR), %LEL, O ₂ - rechargeable battery, black housing	M5IR-XWB0-R-D-D-B-N-00
CO ₂ (IR), %LEL, O ₂ - rechargeable battery and pump, black housing	M5IR-XWB0-R-P-D-D-B-N-00
CO ₂ (IR) - rechargeable battery, black housing	M5IR-00B0-R-D-D-B-N-00
CO ₂ (IR) - rechargeable battery and pump, black housing	M5IR-00B0-R-P-D-D-B-N-00

GasAlertMicro 5 IR Region Codes

For orders outside North America, change order number component “-N” to:

“-E” Europe	“-B” Brazil
“-U” United Kingdom	“-X” Other region with 3-pin UK plug
“-A” Australia	“-Y” Other region with 2-pin UK plug
“-C” China/New Zealand	

Note: Listed above are commonly ordered instrument configurations. To create a custom GasAlertMicro 5 IR detector, use the configurator table on the next page or contact BW Technologies for a copy of the electronic order number configurator.

Gas Legend

CO ₂	Carbon dioxide (B)	CO	Carbon monoxide (M)
%LEL	Combustible (W)	SO ₂	Sulfur dioxide (S)
O ₂	Oxygen (X)	NH ₃	Ammonia (A)
H ₂ S	Hydrogen sulfide (H)	O ₃	Ozone (G)



GasAlertMicro 5 IR
Diffusion version



GasAlertMicro 5 IR
Pump version

GasAlertMicro 5 Series (continued)

GasAlertMicro 5 IR Order Number Configurator

► Sensor - Toxic 2		► Battery	
None (dummy sensor)	0	A	Alkaline
CO and H ₂ S (Duo-Tox dual channel)	Y	R	Rechargeable battery pack and cradle charger
H ₂ S (hydrogen sulfide)	H	► Sampling	
CO (carbon monoxide)	M	D	Diffusion
SO ₂ (sulfur dioxide)	S	P	Motorized sampling pump
NH ₃ (ammonia)	A	► Datalogging	
O ₃ (ozone)	G	D	Datalogging monitor (with Fleet Manager II software)
► Sensor - Toxic 1		► Housing	
None (dummy sensor)	0	Y	Yellow housing
IR (infrared) for CO ₂ (carbon dioxide)	B	B	Black housing
► Sensor - Combustible Gases		► Region	
None (dummy sensor)	0	N	North America
%LEL (combustibles)	W	E	Europe
► Sensor - Oxygen		C	China/New Zealand
None	0	U	United Kingdom
O ₂ (oxygen)	X	A	Australia
► Base Unit		B	Brazil
Base unit	M5IR	X	Other region with 3-pin UK plug
		Y	Other region with 2-pin EU plug

Order number:	M	5	I	R	-		-		-		-	D	-		-		-		-	00
---------------	---	---	---	---	---	--	---	--	---	--	---	---	---	--	---	--	---	--	---	----

For example, the order number for a GasAlertMicro 5 IR configured for O₂, %LEL, CO₂, H₂S and CO and equipped with a rechargeable battery pack and cradle charger, motorized sampling pump, yellow housing and North American power connectivity would be M5IR-XWBY-R-P-D-Y-N-00.

*Note: Some gases cannot be combined in the same GasAlertMicro 5 configuration. Please check with Customer Service for specific availability.

USA 1.888.749.8878
 Canada 1.800.663.4164
 Latin & South America +55.11.3309.1030

Europe +41 (0) 44.943.4300
 Germany +49 (0) 2137.17.6522
 France +33 (0) 442.98.17.70
 Middle East +971.4.4505852

China +86.10.6786.7305
 S.E. Asia +65.6580.3468
 Australia +1.300.729.450
 Other Countries +1.403.248.9226



GasAlertMicro 5 Series (continued)

Confined Space Kits

GasAlertMicro 5 Series deluxe confined space kit - includes manual aspirator kit, sampling probe with holster, five spare auxiliary filters and three spare quick connect fittings, 10 ft. / 3 m sampling hose, carrying holster, calibration cap and 1.0 LPM regulator
Detector, calibration gas and motorized sampling pump sold separately.

Order Number

M5-CK-DL

Carrying case for GasAlertMicro 5 Series with foam and lid insert

M5-CK-CC

Carrying & Protective Accessories

Concussion-proof boot, diffusion units

GA-BM5-1

Concussion-proof boot, pump units

GA-BM5-2

Carrying holster

GA-HM5

Neck strap with safety release

GA-NS-1

Short strap (6 in. / 15.2 cm)

GA-LY-1

Extension strap (4 ft. / 1.2 m)

GA-ES-1

Chest harness

GA-CH-2



Concussion-Proof Boot
 GA-BM5-2
 For GasAlertMicro 5 Series
 pumped units



Concussion-Proof Boot
 GA-BM5-1
 For GasAlertMicro 5 Series
 diffusion units

Deluxe Confined Space Kit
 M5-CK-DL



Carrying Holster
 GA-HM5
 Fits securely on belt

GasAlertMicro 5 Series (continued)

Sampling & Testing Equipment	Order Number
Integral motorized pump kit - Yellow - Black <i>Includes motorized pump cover, 1 ft. / 30 cm sample probe with hydrophobic barrier (water trap) and particulate filters, 5 ft. / 1.5 m sampling hose and two spare pump filters</i>	M5-PUMP M5-PUMPB
Auxiliary pump filter compatible with hose	M5-QCONN-K1
Auxiliary pump filter for use with Generation 2 pump modules (with filter window) - Kit of 5 - Kit of 100	M5-AF-K3 M5-AF-K3-100
Auxiliary pump filter for use with legacy Generation 1 pump modules (without filter window) - Kit of 5 - Kit of 100	M5-AF-K2 M5-AF-K2-100
Replacement pump, yellow	M5-PR-1
Replacement pump, black	M5-PRB-1
Replacement pump nozzle (for use with new Generation 2 pump modules)	M5-PN-1
Replacement diffusion cover, yellow	M5-DC-1
Replacement diffusion cover, black	M5-DCB-1
Replacement ammonia (NH ₃) sensor*	SR-A04
Manual aspirator pump kit with probe (1 ft. / 0.3 m)	GA-AS02
Test cap and hose (1.5 ft. / 0.5 m) replacement	M5-TC-1

Note: For complete list of Sampling & Testing Equipment, see the Sampling Equipment section.



Replacement Test Cap and Hose
M5-TC-1



Auxiliary Pump Filter with Hose Connector
M5-QCONN-K1



Auxiliary Pump Filter
M5-AF-K3 / M5-AF-K3-100
Kit of 5 or 100, for Generation 2 pump modules



Pump Module
M5-PUMP



Auxiliary Pump Filter
M5-AF-K2 / M5-AF-K2-100
Kit of 5 or 100, for legacy Generation 1 pump modules only



Replacement Diffusion Cover
M5-DC-1



Manual Aspirator Pump
GA-AS02
For remote sampling; complete with probe, hose and aspirator pump

GasAlertMicro 5 Series (continued)

Power Accessories

Order Number

Alkaline battery pack, yellow*	M5-BAT0501
Alkaline battery pack, black*	M5-BAT0501B
Alkaline battery pack, European-style safety screws, yellow*	M5-BAT0502
Rechargeable battery pack, yellow*	M5-BAT08
Rechargeable battery pack, black*	M5-BAT08B
Cradle charger and rechargeable battery pack, yellow*	M5-C01-BAT08
Cradle charger and rechargeable battery pack, black*	M5-C01-BAT08B
Cradle charger for rechargeable battery packs	M5-C01
12 Vdc vehicle adaptor cable for use with cradle charger (M5-C01)	GA-V-CHRG4
Replacement power supply for chargers	POWER-UPS-01

*Note: Battery packs and chargers should be used with the new version GasAlertMicro 5 Series gas detectors (red circuit boards).

Datalogging Accessories

Order Number

Multimedia card	M5-MMC
USB memory card reader	CR-MMC-USB1

MicroDock II

Order Number

MicroDock II Automated Calibration and Testing Station:

- Base station and GasAlertMicro 5 Series docking module (charging) with charging cable
- Base station and GasAlertMicro 5 Series docking module (non-charging)
- GasAlertMicro 5 Series docking module (charging), no charging cable
- GasAlertMicro 5 Series docking module (non-charging)

DOCK2-2-1C1K-00-G
DOCK2-2-1J-00-G
DOCK2-0-1K-00-G
DOCK2-0-1J-00-G

For complete MicroDock II system configuration information, see MicroDock II section.



Alkaline Battery Pack
M5-BAT0501/M5-BAT0501B
M5-BAT0502/M5-BAT0502B



Cradle Charger Kit with Battery
M5-C01-BAT08 / M5-C01-BAT08B
Complete with charger and rechargeable battery pack



Rechargeable Battery Pack
M5-BAT08/M5-BAT08B



Cradle Charger
M5-C01
Cradle charger for rechargeable battery packs
(can charge battery pack with or without detector attached)



Vehicle Adaptor
12 Vdc
GA-V-CHRG4
Vehicle adaptor cable for use with cradle charger (M5-C01)

GasAlertMicro 5 Series (continued)

Replacement Sensor Screens	Order Number
Quad sensor screen filters (kit of 2)	M5-SS

Replacement Sensors	Order Number
Replacement carbon dioxide (CO ₂) IR sensor	SR-B04
Replacement carbon monoxide (CO) sensor	SR-M04-SC
Replacement carbon monoxide (CO-H) sensor, H ₂ resistant	PS-RM04H
Replacement chlorine (Cl ₂) sensor*	PS-RC10
Replacement chlorine dioxide (ClO ₂) sensor*	SR-V04
Replacement combustible (% LEL) sensor with heavy duty silicone filter†	SR-W04
Replacement combustible (% LEL) sensor without heavy duty silicone filter†	SR-W04-UF
Replacement Duo-Tox sensor - carbon monoxide (CO) and hydrogen sulfide (H ₂ S)	D4-RHM04
Replacement hydrogen cyanide (HCN) sensor	PS-RZ10
Replacement hydrogen sulfide (H ₂ S) sensor	PS-RH04S
Replacement nitrogen dioxide (NO ₂) sensor	PS-RD04
Replacement oxygen (O ₂) sensor	SR-X10-C1
Replacement ozone (O ₃) sensor*	SR-G04
Replacement phosphine (PH ₃) sensor	SR-P04
Replacement sulfur dioxide (SO ₂) sensor	PS-RS04
Replacement volatile organic compounds (VOC) PID sensor, 10.6 eV*	SR-Q07
Replacement PID lamp, (10.6 eV) for PID sensor (SR-Q07)*	RL-PID10.6
Replacement electrode stacks for PID sensor (SR-Q07) (kit of 2)	M5PID-ES-1
Cleaning kit for PID sensor	M5PID-CLN-K1
Dummy sensor for 3-pin O ₂ or 3-pin Duo-Tox locations	SR-DUMM1
Dummy sensor for combustible (LEL) location	SR-DUMM2
Dummy sensor for PID location	SR-DUMM3

Note: All sensors come with a 2 year warranty unless marked with an asterisk (*), denoting 1 year warranty.

†Advisory: Detectors are equipped on a standard basis with SR-W04 combustible sensors. This sensor includes a heavy duty silicone filter that make it ideal for use in environments that have known sources of silicone or vapors containing silicon. The SR-W04 silicone filter equipped sensor should not be used when monitoring diesel, kerosene, jet fuel or other heavy hydrocarbon vapors with flashpoint temperatures above 38°C (100°F).

Calibration & Testing Equipment

For calibration and testing equipment for this product, please see pages 86-89.

PID Cleaning Kit

M5PID-CLN-K1
For PID sensors



**Replacement
10.6 eV PID Lamp**
RL-PID10.6
For PID sensors



**Replacement
Electrode Stack**
M5PID-ES-1
For PID sensors



Replacement PID Sensor
SR-Q07



Replacement IR Sensor
SR-B04

GasAlertMicro 5 Series (continued)

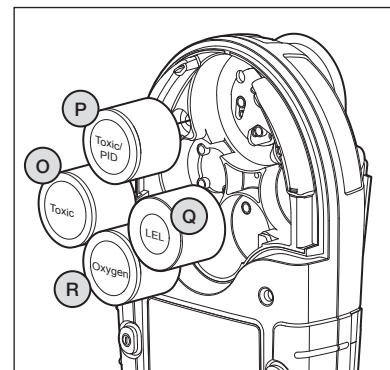
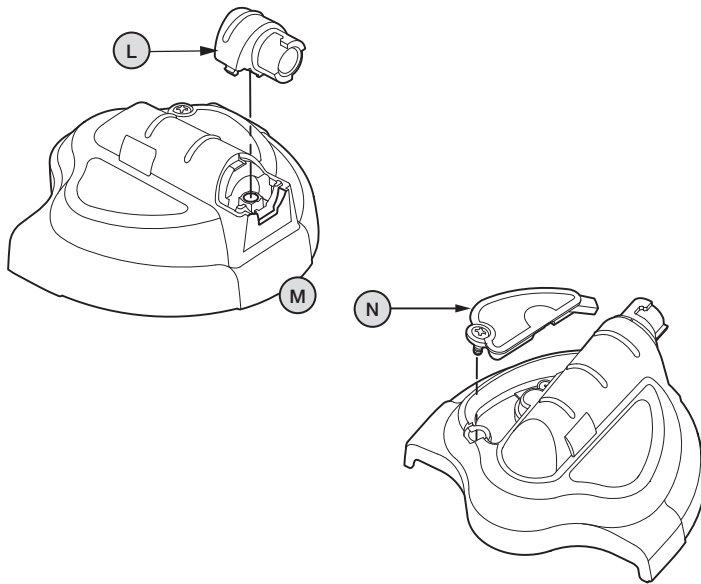
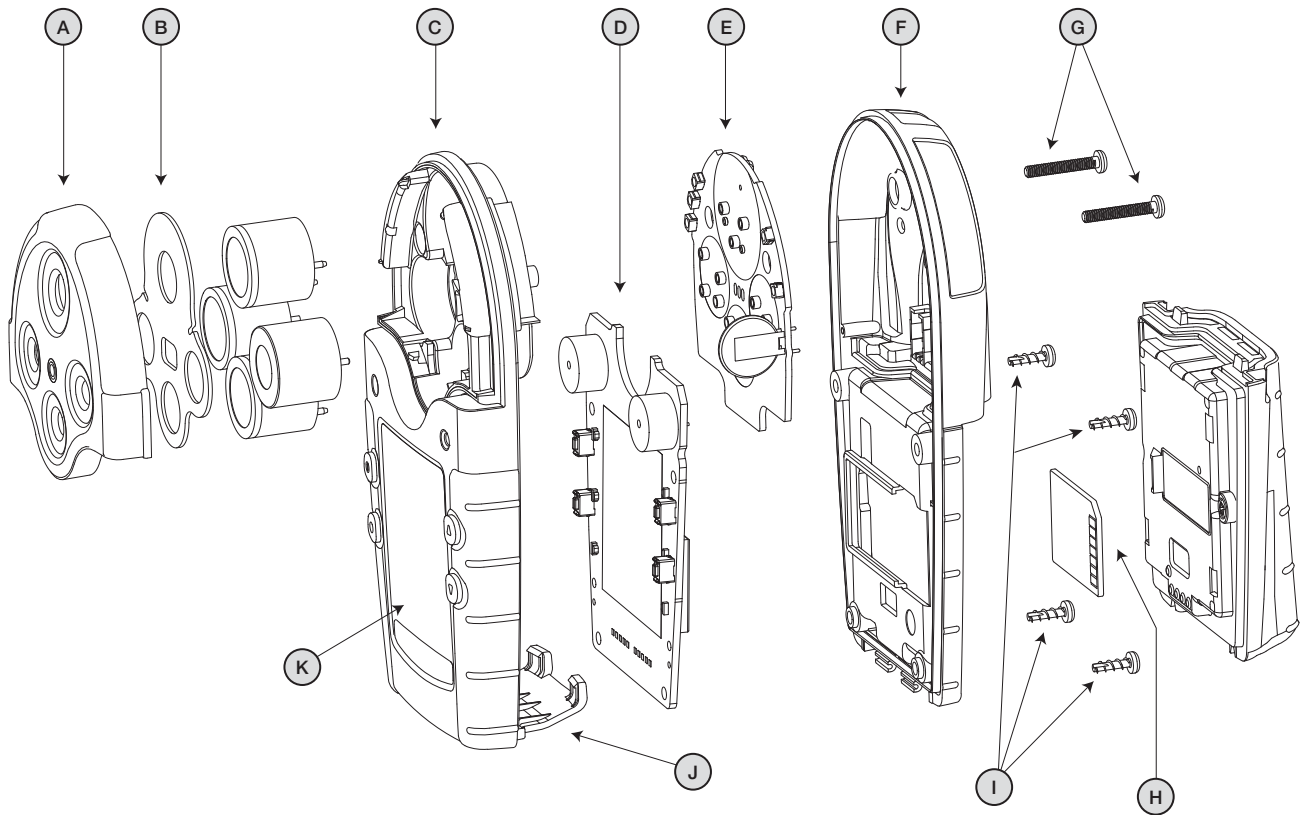

Note: Please refer to the instrument's documentation (shipped with the product or available at www.gasmonitors.com) for complete instructions on common service procedures. Improper servicing or maintenance may affect warranty eligibility. Honeywell assumes no liability for damages resulting from improper servicing or maintenance.

GasAlertMicro 5 Series (continued)

Legend	Service Parts	Order Number
C	Replacement front enclosure (yellow) for GasAlertMicro 5 Series	M5-FC1
	Replacement front enclosure (black) for GasAlertMicro 5 Series	M5-FC1B
F	Replacement back enclosure (yellow) with screws for GasAlertMicro 5 Series	M5-BC1
	Replacement back enclosure (black) with screws for GasAlertMicro 5 Series	M5-BC1B
A	Replacement diffusion cover (yellow) for GasAlertMicro 5 Series	M5-DC-1
	Replacement diffusion cover (black) for GasAlertMicro 5 Series	M5-DCB-1
	Replacement alligator-style clip with screw (stainless steel)	GA-AG-2
	Replacement battery latch	M5-BL-1
D	Replacement main PCB for GasAlertMicro 5 Series	M5-DL2-MPCB3
E	Replacement sensor PCB for GasAlertMicro 5	M5-SPCB3
	Replacement sensor PCB for GasAlertMicro 5 PID	M5PID-SPCB3
	Replacement sensor PCB for GasAlertMicro 5 IR	M5IR-SPCB1
L	Replacement nozzle for generation 2 GasAlertMicro 5 Series pump module (with filter window)	M5-PN-1
	Hose assembly with syringe filter	M5-QCONN-K1
J	Replacement battery latch for GasAlertMicro 5 Series	M5-BL-1
H	Replacement multimedia card for GasAlertMicro 5 Series	M5-MMC
I	Replacement screw kit for GasAlertMicro 5 Series	M5-SCREW-K1
	Replacement screwdriver and alkaline battery pack screws for GasAlertMicro 5 Series	M5-ALLEN

How to Replace a Sensor

1. With detector OFF, use No. 1 Phillips screwdriver to remove 2 screws (G) from back enclosure (F) on either side of the belt clip
2. Lift diffusion cover (A) or pump module straight up
3. Remove sensor (O-R) by pulling straight up from PCB (E)
4. Insert new sensor (O-R) into PCB (E)
5. Replace diffusion cover (A) or pump module
6. Replace 2 screws (G) in back enclosure (F) and hand-tighten until firm

How to Replace the Sensor Screen

1. With detector OFF, use No. 1 Phillips screwdriver to remove 2 screws (G) from back enclosure (F) on either side of the belt clip
2. Lift diffusion cover (A) or pump module straight up
3. Remove sensor screen (B) by pulling it straight up from diffusion cover (A) or pump module
4. Insert sensor screen (B) into diffusion cover (A) or pump module
5. Replace diffusion cover (A) or pump module
6. Replace 2 screws (G) in back enclosure (F) and hand-tighten until firm

Note: Please refer to the instrument's documentation (shipped with the product or available at www.gasmonitors.com) for complete instructions on common service procedures. Improper servicing or maintenance may affect warranty eligibility. Honeywell assumes no liability for damages resulting from improper servicing or maintenance.