

#27540

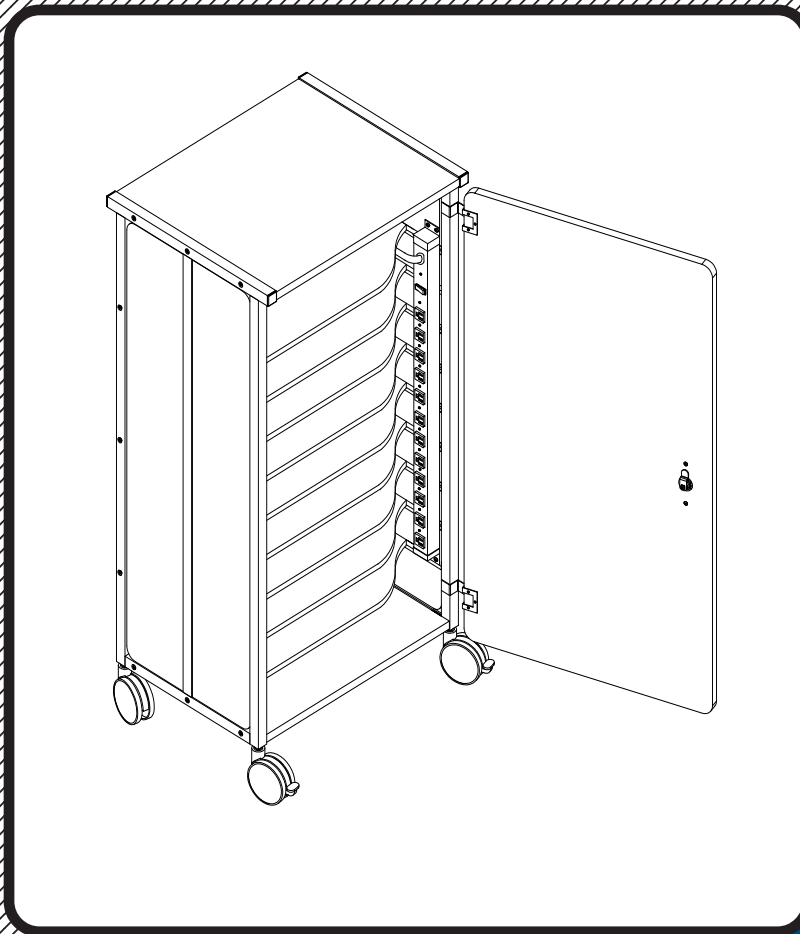









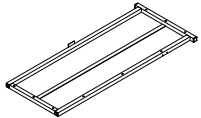

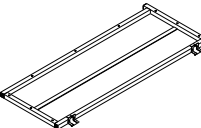
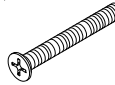
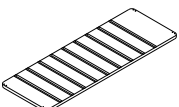
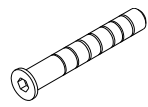
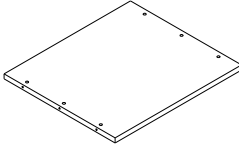

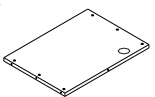

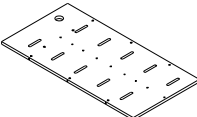

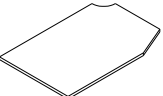
10 Unit Mobile Laptop Charging Station

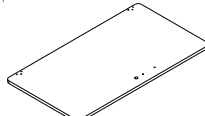



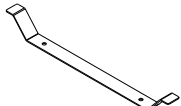

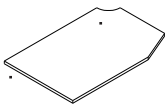
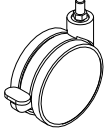
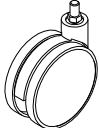
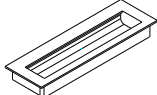
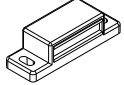

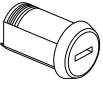
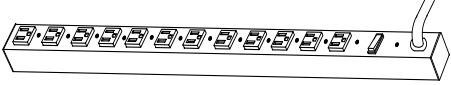
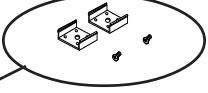

Touchboards

205 Westwood Ave, Long Branch, NJ 07740
Phone: 866-94 BOARDS (26273) / (732)-222-1511
Fax: (732)-222-7088 | E-mail: sales@touchboards.com



Assembly Instructions

Part	Drawing	Description	Qty	Part	Drawing	Description	Qty
Hardware List							
P-1		Left Leg Welded	1 EA	A		Phil Screw M6X15mm	2 EA
P-2		Right Leg Welded	1 EA	A1		CS Phil Screw M6X50mm	18 EA
P-3		Slotted End Panel	2 EA	A2		Wood Screw M7x50mm	1 EA
P-4		Top Panel	1 EA	A3		CS Wd Screw M3x12mm	12 EA
P-5		Bottom Panel	1 EA	A4		Phil Pan Screw M4x12mm (Door Knobs)	2 EA
P-6		Back Panel	1 EA	A5		Pan Hd Screw M4x18mm	10 EA
P-7		Shelf	8 EA	A6		CS Wood Screw M3x8mm	1 EA
P-8		Door	1 EA	B		Threaded Post M6x16	2 EA
P-9		Electrical Mount Cap	2 EA	B-1		Wood Dowel	9 EA
P-10		Cord Wrap	1 EA	C		Lock Washer-Casters	4 EA
P-11		Middle Shelf	1 EA	D		4" Locking Caster	2 EA
				E		4" Caster	2 EA
				F		Door Handle	1 EA
				G		Magnet	1 EA
				G1		Metal Plate	1 EA
				J		Middle Shelf Bracket	2 EA

Part	Drawing	Description	Qty	Part	Drawing	Description	Qty
Hardware List							
K1		Lock Cylinder	1 EA	<div data-bbox="834 247 1490 638" style="border: 1px solid black; padding: 10px; margin-bottom: 20px;"> <p>#58188- 12 Outlet Electrical Strip</p>  <p>These parts are not used.</p>  </div> <div data-bbox="951 1157 1438 1566" style="border: 1px solid black; padding: 10px; margin-bottom: 20px;"> <p><i>Should you require assistance during assembly, please call our Customer Service Department Monday - Friday 8 a.m. - 5 p.m. Central Standard Time Toll-Free Customer Service</i> 1-800-749-2258</p> </div> <div data-bbox="878 1612 1484 1829" style="border: 1px solid black; padding: 10px;"> <p>Missing Parts or UPS Damaged Parts For Your Convenience you can EMAIL us at <u>support@moorecoinc.com</u> 24HOURS 7 DAYS A WEEK</p> </div>			
K2		Lock Washer	1 EA				
K3		Lock Hex	1 EA				
K4		Lock Retainer	1 EA				
K5		1/4" Phil Head Lock Screw	1 EA				
L		Key	2 EA				
M1		Grommet Sleeve	1 EA				
M2		Grommet Cap	1 EA				
N		Caster Wrench	1 EA				
P		Allen Wrench	1 EA				

Do not use unless all screws are tight. At least every six months, check all screws to be sure they are tight. If parts are missing, broken, damaged, or worn, stop use of the product until repairs are made by your dealer using factory authorized parts.

#27540 Mobile Laptop Charging Station Assembly Diagram

To Assemble:

1. Identify and Separate all the Parts and Hardware.
2. Attach Right Leg Welded (P2) to the Top and bottom Panels (P4 & P5) using 6 screws (A1) as shown in illustration #1.
3. Attach Back Panel (P6) to the Right Leg Welded (P2) using 3 screws (A1) as shown in illustration #1.

Illustration # 1



205 Westwood Ave, Long Branch, NJ 07740
Phone: 866-94 BOARDS (26273) / (732)-222-1511
Fax: (732)-222-7088 | E-mail: sales@touchboards.com

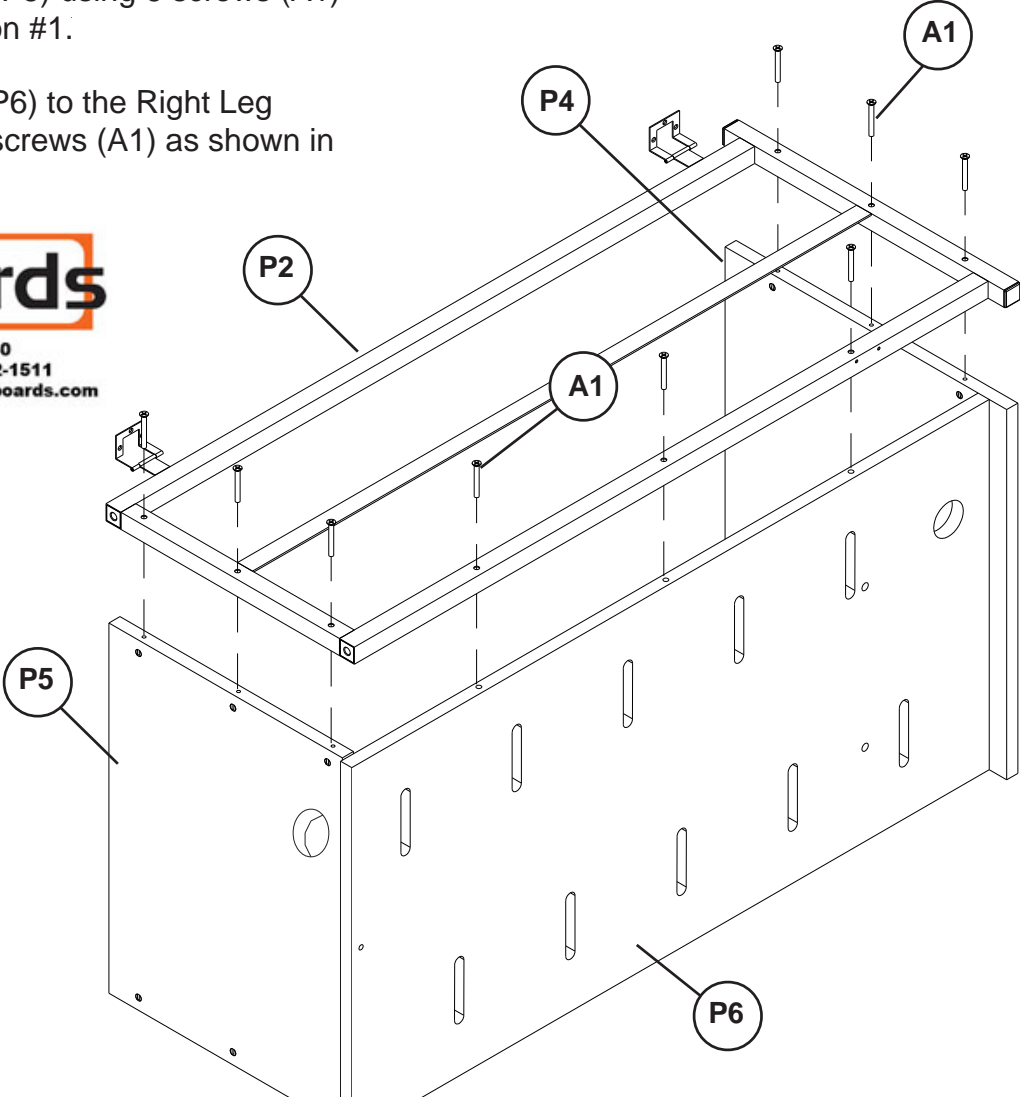

Important

The Balt product you have purchased is guaranteed against material and workmanship defects. This guarantee extends 1 year from date of purchase. Should this product fail to function satisfactorily under normal use due to defect or imperfection, the defective part or product will be replaced. Damage caused by common carriers during shipment is not included in this guarantee.

This guarantee sets forth all applicable guarantees and remedies. No other warranty, expressed or implied shall apply. Failure to follow instructions found in Important Information Section of Owner Sheet shall void the guarantee. Consequential or incidental damages and or costs are not refundable.

Illustration # 2

4. Press Grommet Sleeve (M1) in round opening in the Back Panel (P6) as shown in illustration #2.

5. Attach Magnet (G) to the Right Leg Welded (P2) using 2 Screws (A5).

6. Attach Cord Wrap (P10) to the Back Panel (P6) using 2 screws (A) and 2 Threaded Posts (B).

7. Secure Back Panel (P6) to the Bottom Panel (P5) using 1 Screw (A2) as shown in illustration #2.

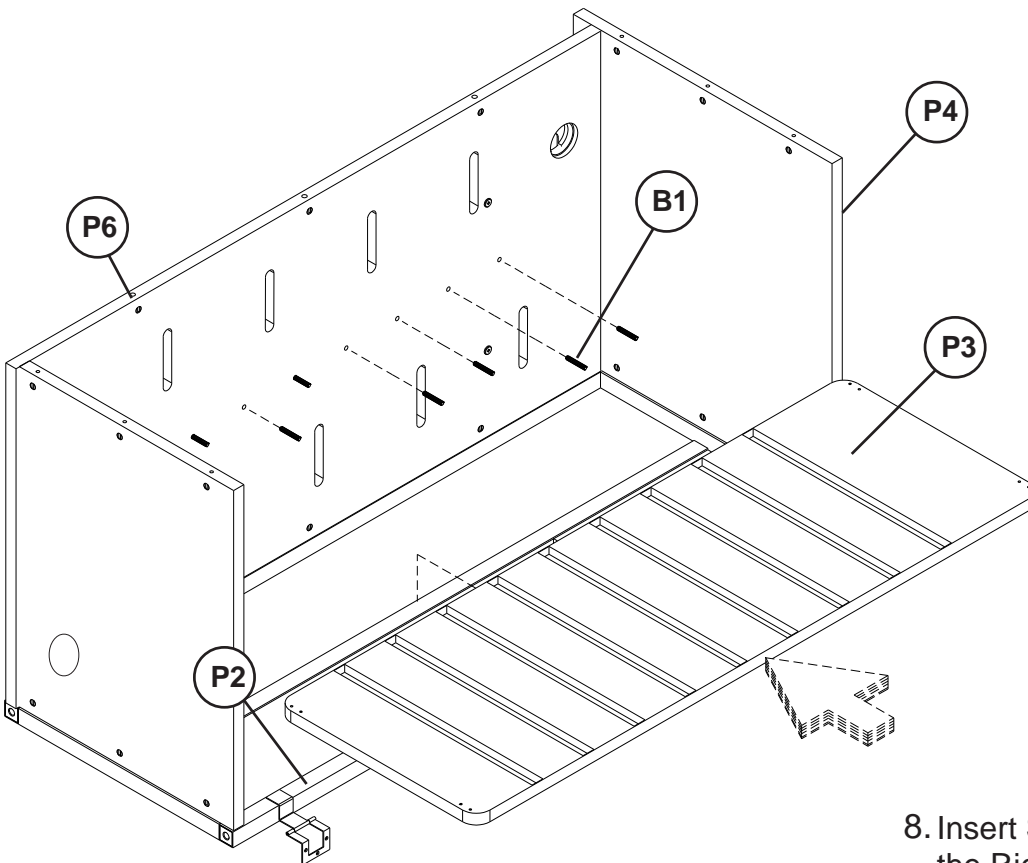
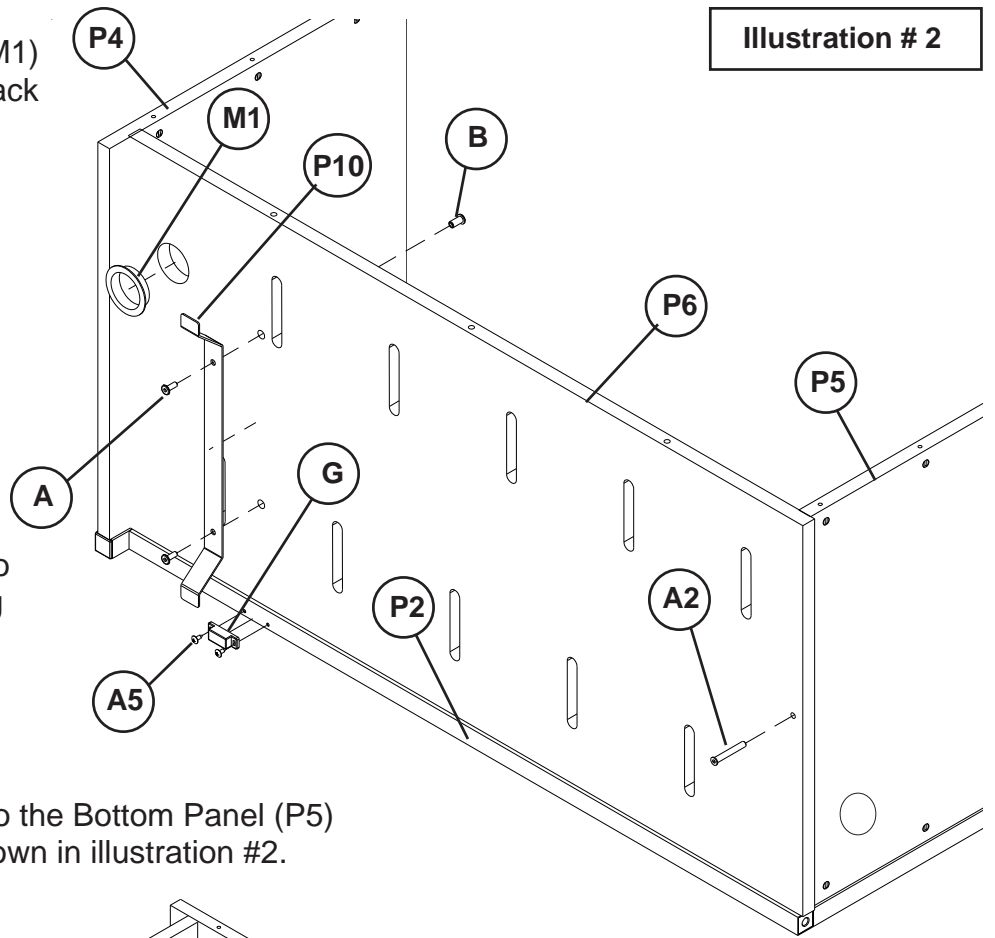
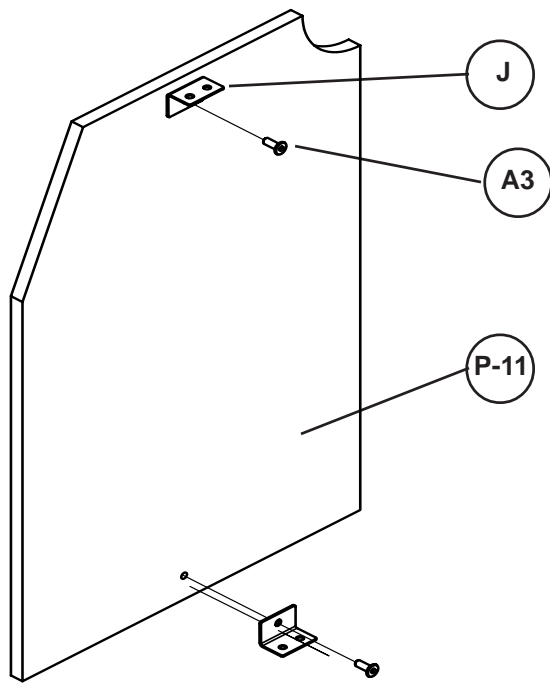

Illustration # 3

8. Insert Slotted End Panel (P3) in the Right Leg Welded as shown in illustration #3.

9. Insert 9 Wood Dowels (B1) in holes in the Back Panel (P6).

Illustration # 4A



10. Attach 2 Middle Shelf Brackets (J) to the bottom side of Middle Shelf (P-11) using 2 CS Wd Screws (A3) as shown in Illustration # 4A.

Attach the center shelf to the sides

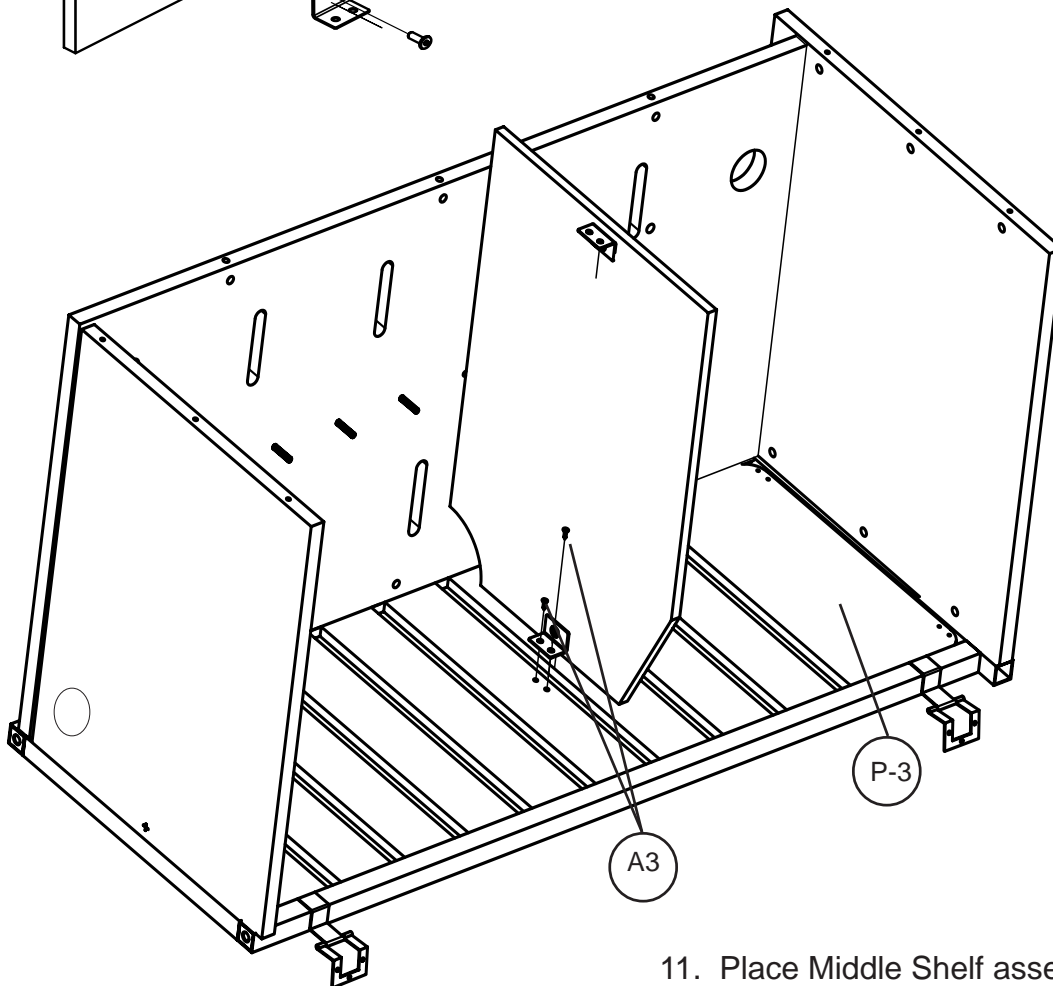

11. Place Middle Shelf assembly from Step 10 in the fourth slot down from the top of Slotted End Panel (P-3). Use 2 CS Screws (A3) to attach through the Middle Shelf Bracket and into the Slotted End Panel's predrilled holes as shown in Illustration # 4B.

Illustration # 4B

12. Slide 8 Shelves (P7) over Dowels (B1) and into slots in Slotted End Panel (P3) as shown in illustration # 4C.

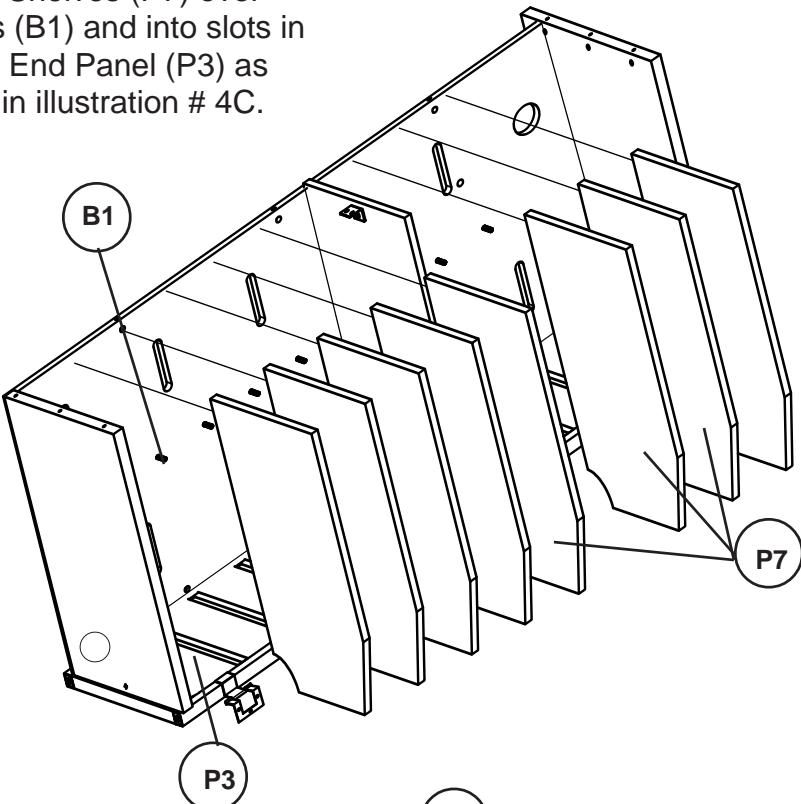
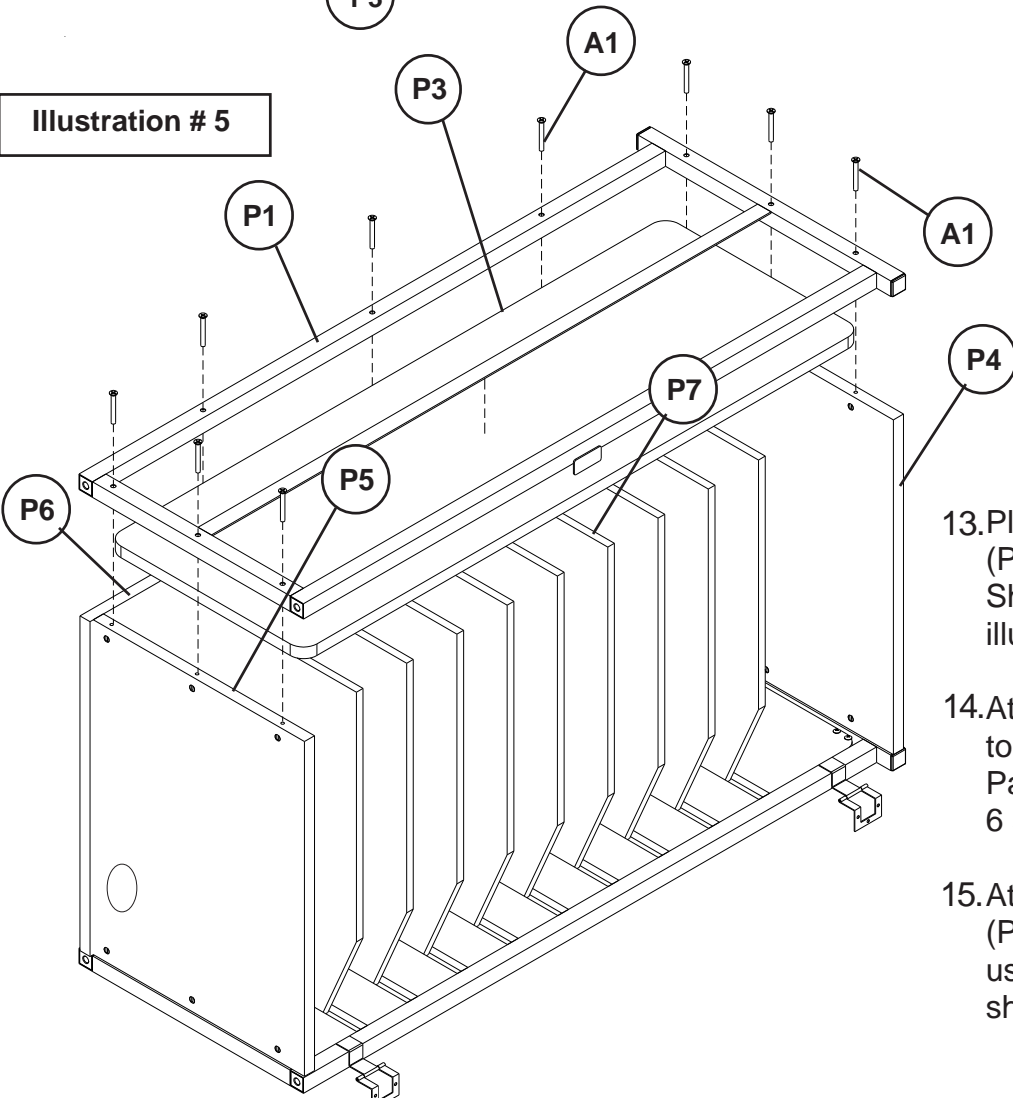

Illustration # 5



13. Place Slotted End Panel (P3) over the end of 9 Shelves (P7) as shown in illustration #5.

14. Attach Left Leg Welded (P1) to the Top and bottom Panels (P4 & P5) using 6 screws (A1) .

15. Attach the Left Leg Welded (P1) to the Back Panel (P6) using 3 screws (A1) as shown in illustration #5.

16. Attach 2 Locking Casters (D), and 2 Lock Washers (C) to the front of Welded Legs (P1 & P2).

Illustration # 6

17. Attach 2 Casters (E) and 2 Lock Washers (C) to the back of Welded Legs (P1 & P2). Tighten all Casters using Caster Wrench (N). Attach Bracket (J) that is under Middle Shelf (P11) to left (P3) End Panel using 2 CS Screws (A3) as shown in detail.

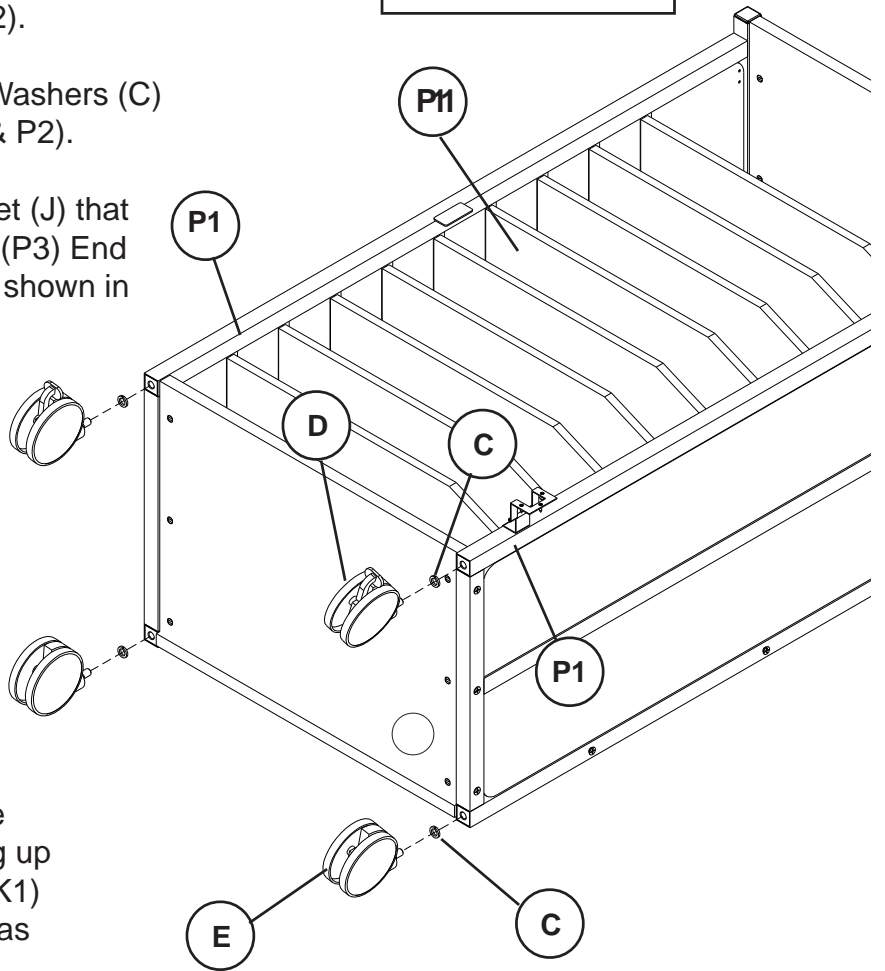
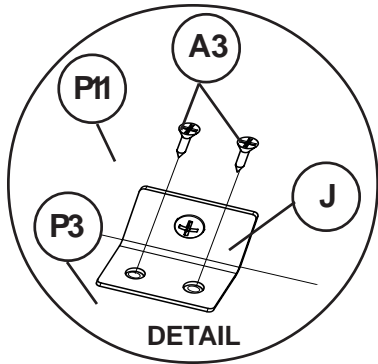

18. Place the Right Door (P8) with the Predrilled holes (for hinges) facing up and Insert 1 each Lock Cylinder (K1) through the hole in the Door (P8) as shown in illustration #7.

19. Secure Lock Cylinder (K1) using the Lock Washer (K2) and the Lock Hex (K3). (*FINGER TIGHTEN ONLY.*)

20. Slide Lock Retainer (K4) over the square end of Lock Cylinder (K1). Secure using the 1/4" Phil Head Lock Screw (K5).

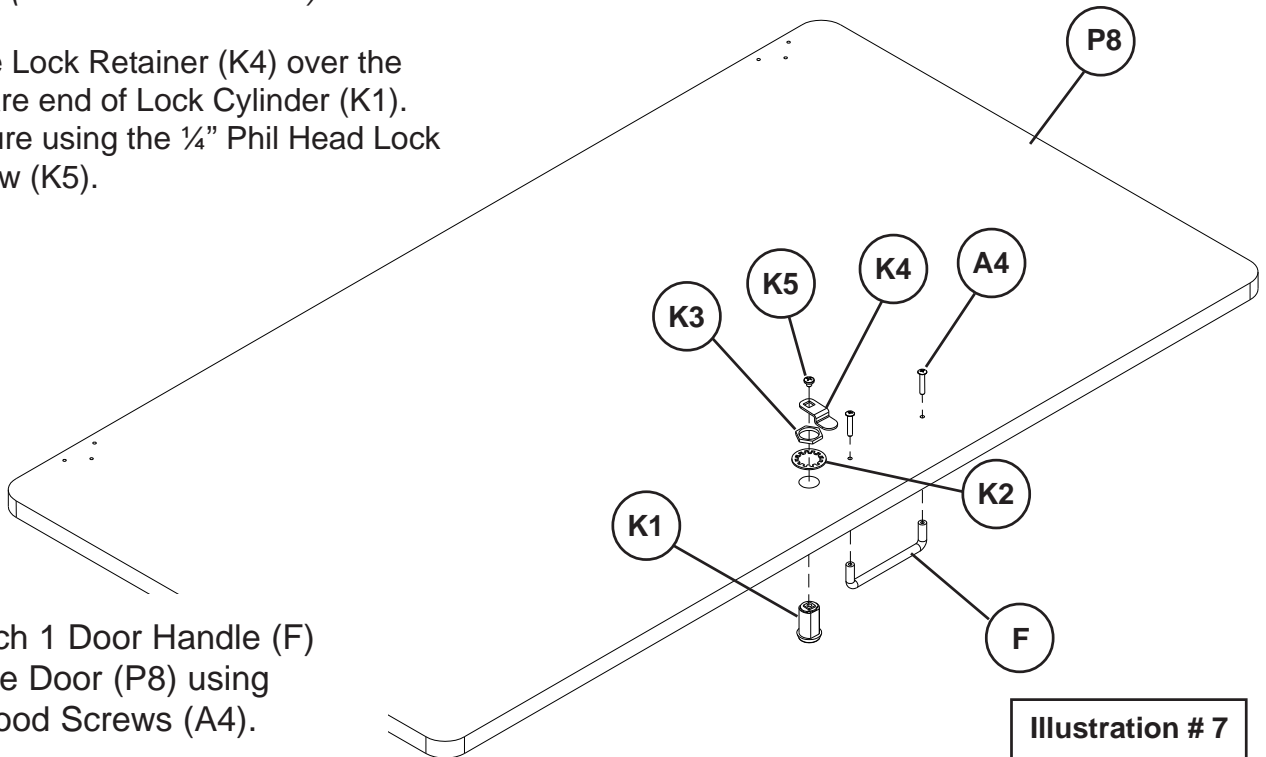

Illustration # 7

21. Attach 1 Door Handle (F) to the Door (P8) using 2 Wood Screws (A4).

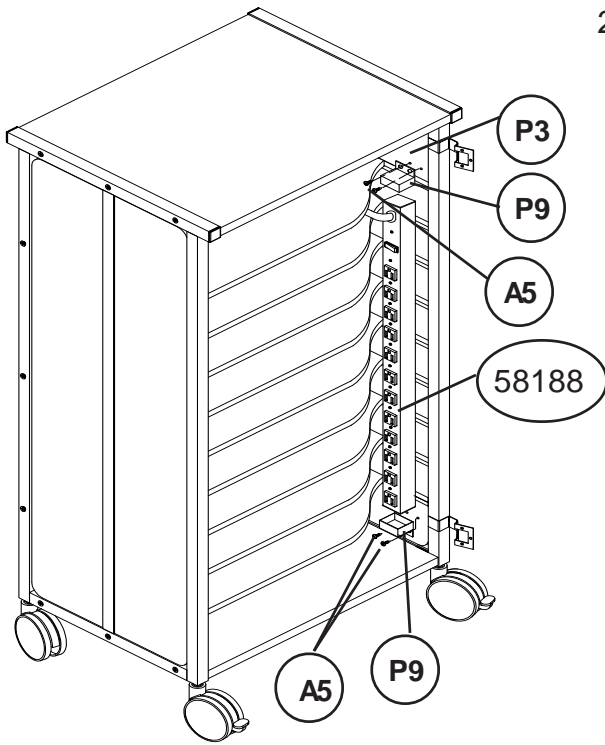

Illustration # 8a

22. Attach 1 Electrical-12 Outlet (#58188) to the Slotted Panel (P-3) on the Right Side using 2 screws (A5) through an Electrical Mount Cap (P9) on each end. Position caps over the predrilled holes in the side panel as shown in illustration #8a.

23. Attach the Right Door (P10) to the Right Leg Welded using 6 Screws (A3) as shown in illustration #8b.

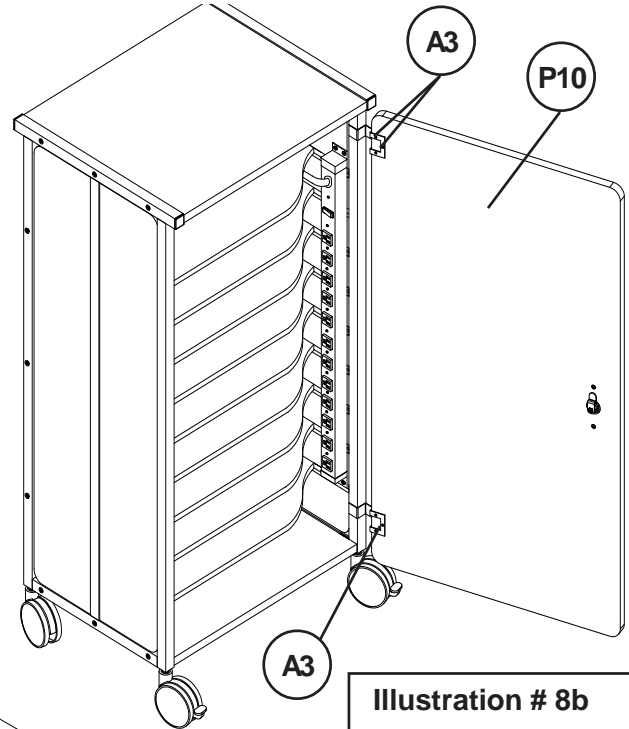

Illustration # 8b

Touchboards

205 Westwood Ave, Long Branch, NJ 07740
 Phone: 866-94 BOARDS (26273) / (732)-222-1511
 Fax: (732)-222-7088 | E-mail: sales@touchboards.com

24. Before tightening the Lock Hex (K3), Insert the Key (L) and turn lock. Be sure that Lock Retainer (K4) turns 90 degrees and rotates behind Door Stop on the Left Leg Welded (P1).

TIGHTEN LOCK HEX (K3).

25. Route electric cords across the top shelf and through the Grommet Sleeve (M1) in the Back Panel (P7) and out the back of the unit as shown in illustration #9.

26. Snap Grommet Cap (M2) over top of Grommet Sleeve (M1).

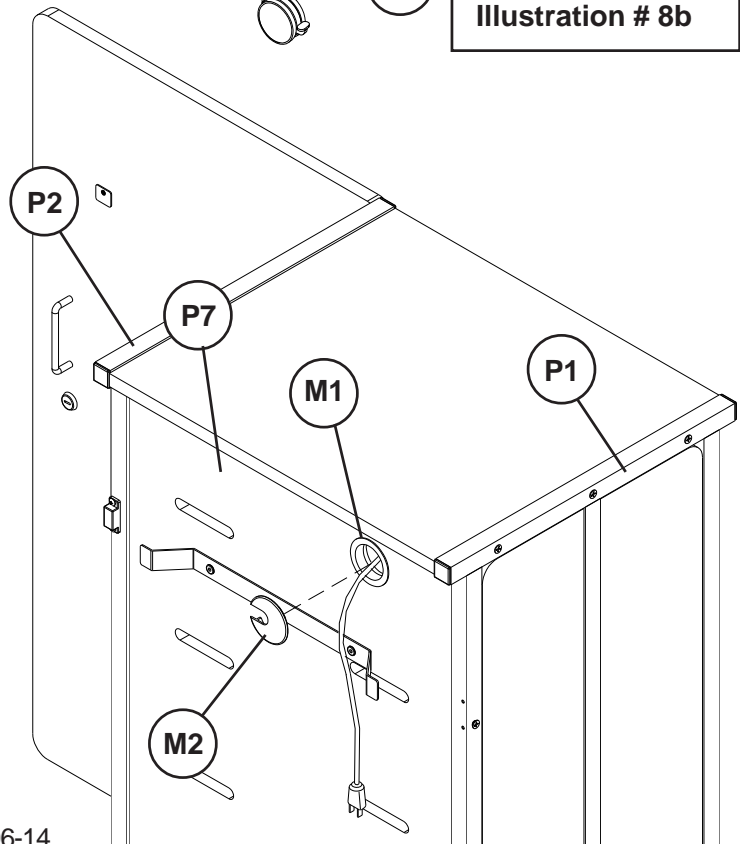

Illustration # 9

27540_02-06-14