

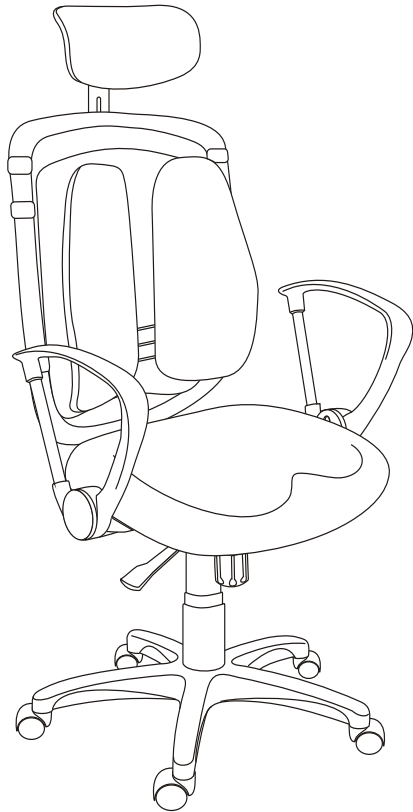

#34556 Spine Align Chair



Missing Parts or UPS Damaged Parts
For Your Convenience, you can Email us at
support@moorecoinc.com
24 Hours a Day 7 Days a Week

Touchboards
205 Westwood Ave, Long Branch, NJ 07740
Phone: 866-94 BOARDS (26273) / (732)-222-1511
Fax: (732)-222-7088 | E-mail: sales@touchboards.com

Should you require assistance during assembly, please call our Customer Service Department Monday - Friday 8 a.m. - 5 p.m. Central Standard Time 1-800-749-2258

Parts/Hardware

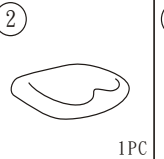
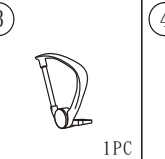
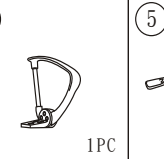
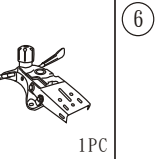
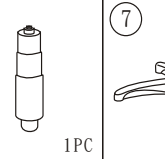
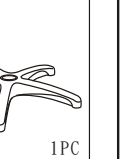
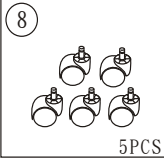
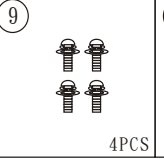
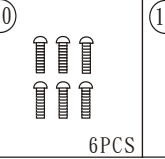
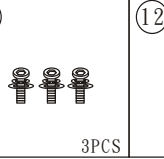
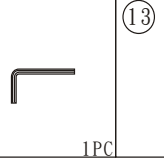
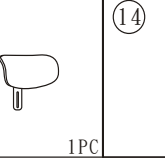
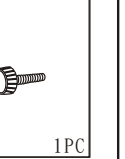
 1PC	 1PC	 1PC	 1PC	 1PC	 1PC	 1PC
 5PCS	 4PCS	 6PCS	 3PCS	 1PC	 1PC	 1PC

Do not use unless all screws are tight. At least every six months, check all screws to be sure they are tight. If parts are missing, broken damaged or worn, stop using the product until repairs are made by your dealer using factory authorized parts.

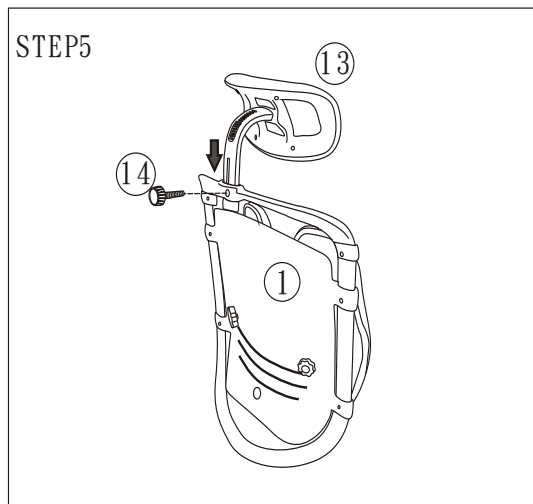
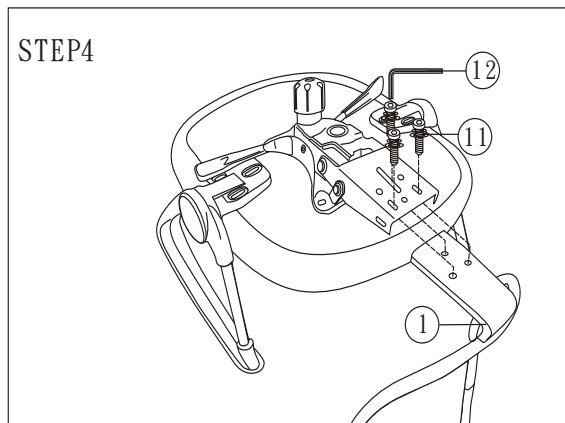
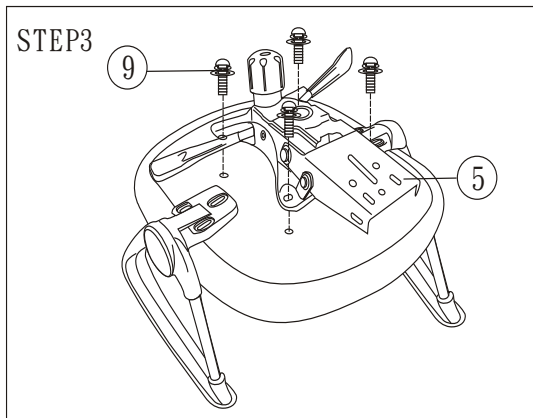
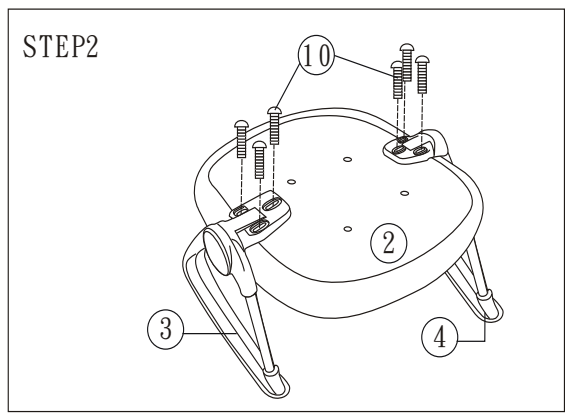
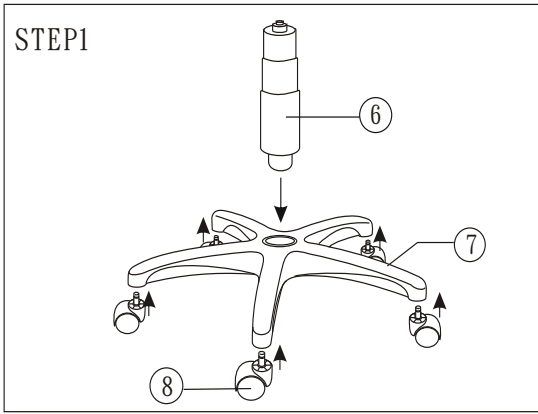

Important

The Balt product you have purchased is guaranteed against material and workmanship defects. This guarantee extends 1 year from date of purchase. Should this product fail to function satisfactorily under normal use due to defect or imperfection, the defective part or product will be replaced. Damage caused by common carriers during shipment is not included in this guarantee.

This guarantee sets forth all applicable guarantees and remedies. No other warranty, expressed or implied shall apply. Failure to follow instructions found in Important Information Section of Owner Sheet shall void the guarantee. Consequential or incidental damages and or costs are not refundable.