

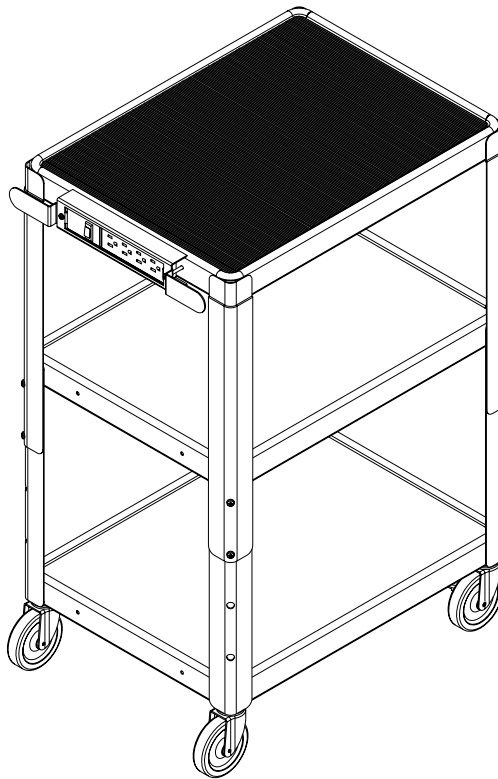

#85892 Adjustable Height Utility Cart









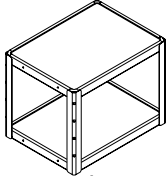

Touchboards

205 Westwood Ave, Long Branch, NJ 07740
Phone: 866-94 BOARDS (26273) / (732)-222-1511
Fax: (732)-222-7088 | E-mail: sales@touchboards.com

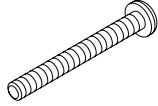
Assembly Instructions

#85892

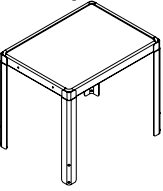
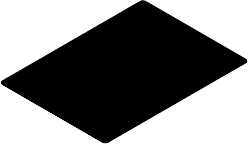
Adjustable Height Utility Cart

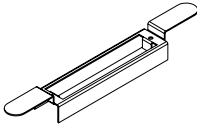
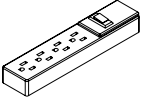
| Part | Drawing | Description | Qty | Part | Drawing | Description | Qty |
|------|---|------------------------|------|---|---------|-------------|-----|
| P1 |  | Welded Base | 1 EA | Hardware List A  Phillip's Head M6 x 14mm 8 EA A1  Phillip's Head M5 x 45 mm 2 EA B  M6 Hex Nut 8 EA C  M5 Nut with Shoulder 2 EA D  Lock Washer with Teeth 8 EA | | | |
| P2 |  | Welded Top Shelf | 1 EA | | | | |
| P3 |  | Non-Skid Rubber Mat | 1 EA | | | | |
| P4 |  | 4" Locking Caster | 2 EA | | | | |
| P5 |  | 4" Non-Locking Caster | 2 EA | | | | |
| P6 |  | Electrical Cord Winder | 1 EA | | | | |
| P7 |  | Electrical Outlet | 1 EA | | | | |

Missing Parts or UPS Damaged Parts

For Your Convenience you can
EMAIL us at
furniture@baltinc.com
24HOURS 7 DAYS A WEEK

***Should you require assistance during assembly,
please call our Customer Service Department
Monday - Friday 8 a.m. - 5 p.m.
Central Standard Time 1-800-749-2258***

Do not use unless all screws are tight. At least every six months, check all screws to be sure they are tight. If parts are missing, broken, damaged, or worn, stop use of the product until repairs are made by your dealer using factory authorized parts.

#85892 Adjustable Height Utility Cart Assembly Diagram



Illustration # 1

**READ THROUGH INSTRUCTIONS FROM BEGINNING TO
END BEFORE STARTING TO ASSEMBLE UNIT.**

- 1.) Identify and Separate all the Parts
- 2.) Slide Welded Top Shelf (P-2) over the Welded Base (P-1) and secure at desired height using 4 screws (A), 4 Lock Washers with Teeth (D), and 4 M6 Hex Nuts (B).
- 3.) Attach Cord Winder (P-6) and Electrical Strip (P-7) using 2 screws (A1) and M5 Hex Nuts with Shoulder (C).
- 4.) Lay the Non-Slip Mat (P-3) atop the Welded Top Shelf (P-2).
- 5.) Tighten all screws using Phillip's head screwdriver (Not Provided).

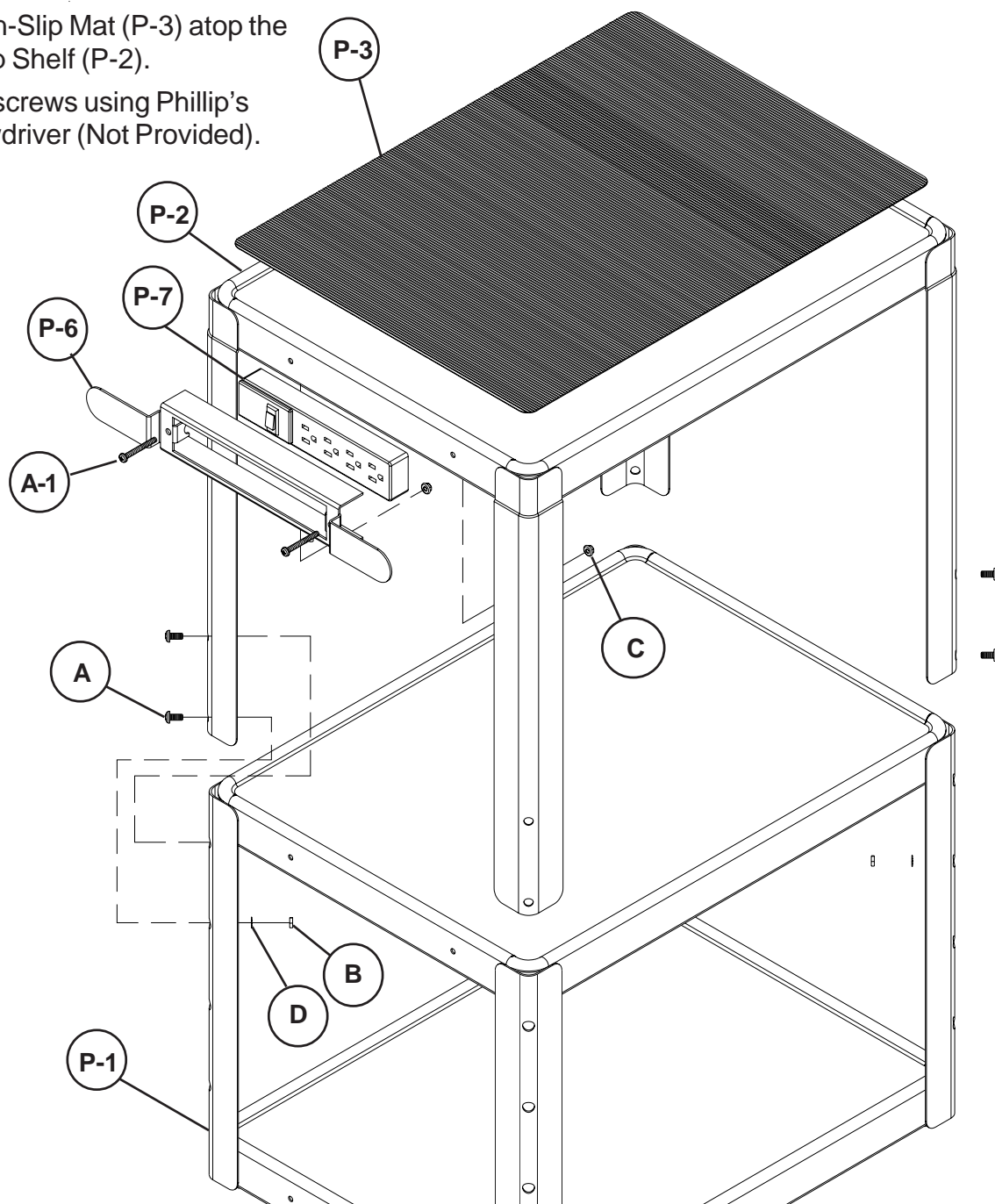

6.) Press in both locking and non-locking casters (P-4 and P-5) into the factory installed nylon inserts in the Welded Base (P-1).

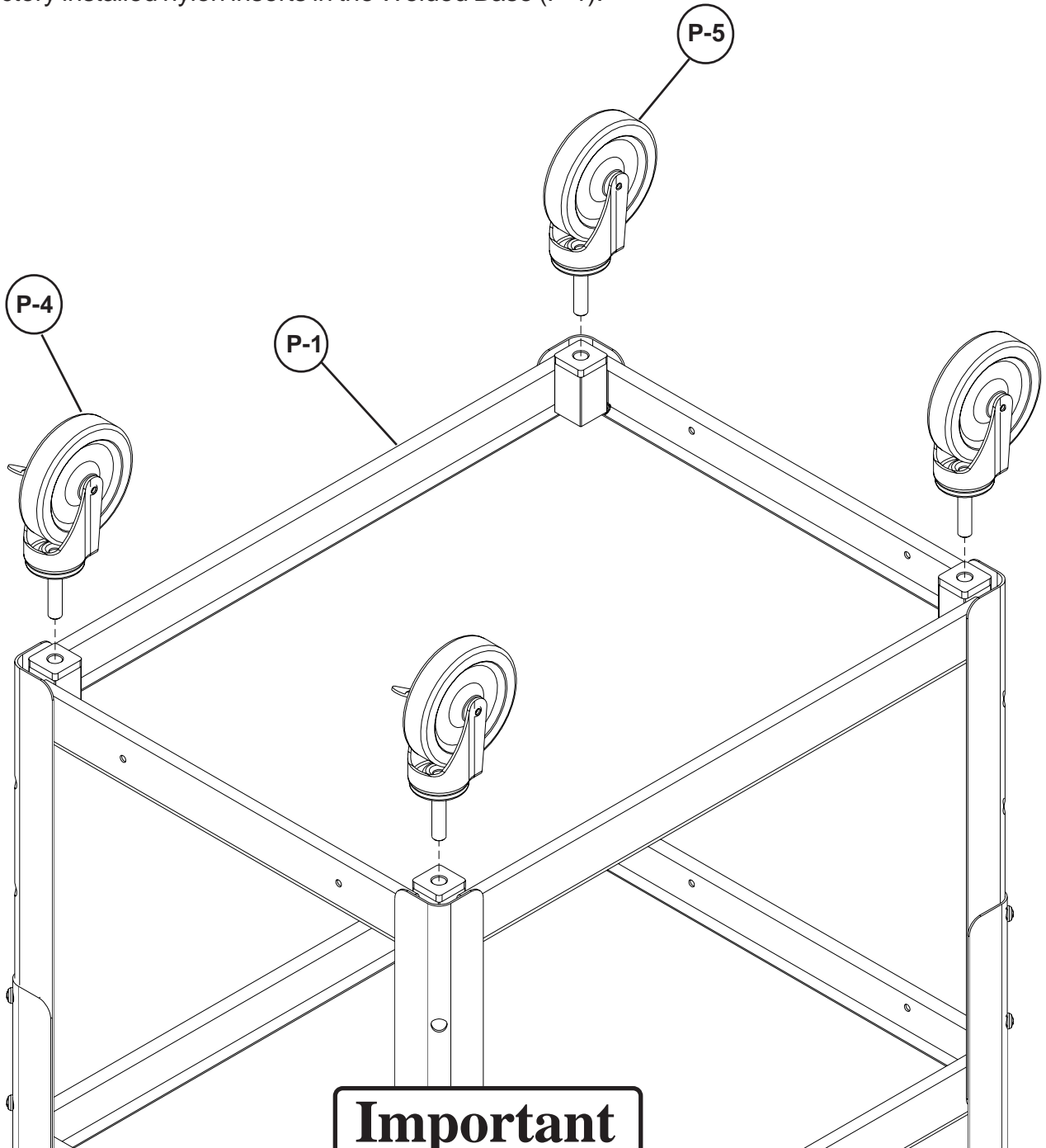

Important

The Balt product you have purchased is guaranteed against material and workmanship defects. This guarantee extends 1 year from date of purchase. Should this product fail to function satisfactorily under normal use due to defect or imperfection, the defective part or product will be replaced. Damage caused by common carriers during shipment is not included in this guarantee.

This guarantee sets forth all applicable guarantees and remedies. No other warranty, expressed or implied shall apply. Failure to follow instructions found in Important Information Section of Owner Sheet shall void the guarantee. Consequential or incidental damages and or costs are not refundable.

#85892-Adjustable Height Utility Cart



For more information
1-800-749-2258

