

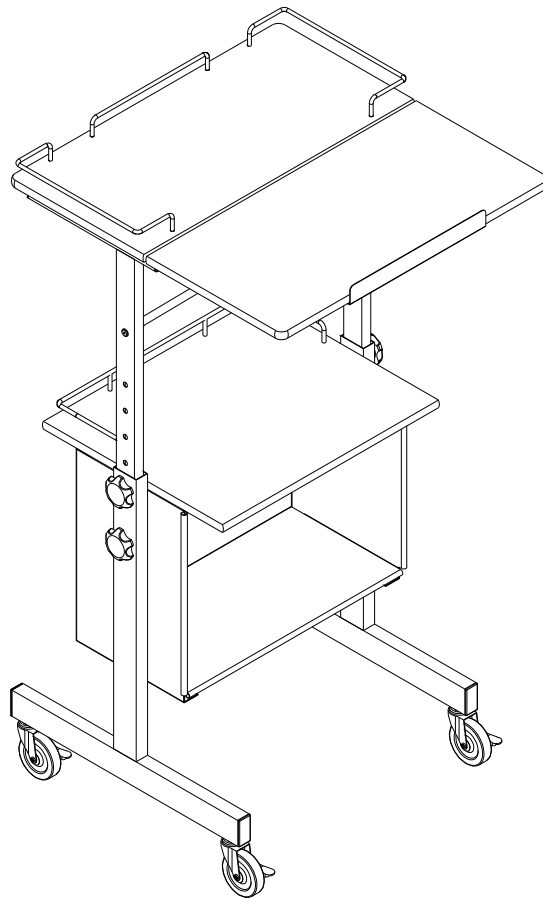

#89786 DIVERSITY STAND

Adjustable Height Presentation Center













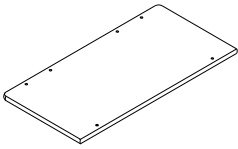
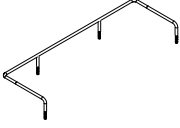
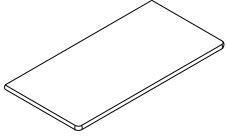
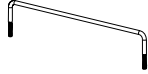
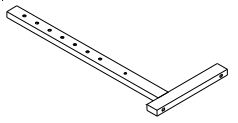
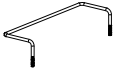
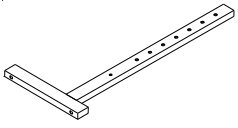
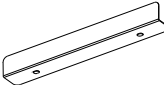
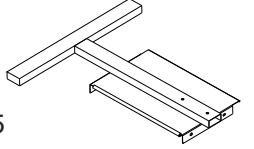
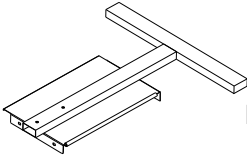

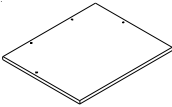

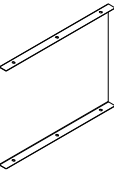
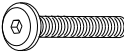
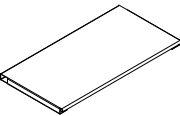

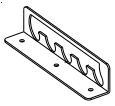

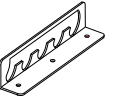
Touchboards

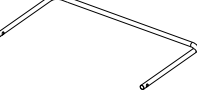
205 Westwood Ave, Long Branch, NJ 07740
Phone: 866-94 BOARDS (26273) / (732)-222-1511
Fax: (732)-222-7088 | E-mail: sales@touchboards.com

Assembly Instructions

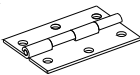
DIVERSITY STAND

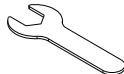
Adjustable Height Presentation Center

Part	Drawing	Description	Qty	Part	Drawing	Description	Qty
P1		LCD Platform	1 EA	P13		Shelf Rail	1 EA
P2		Tilt Platform	1 EA	P14		LCD Front Rail	1 EA
P3		Left Upper Insert	1 EA	P15		LCD Side Rail	2 EA
P4		Right Upper Insert	1 EA	P16		Paper Stop	1 EA
P5		Left Leg Receiver	1 EA	Hardware List			
P6		Right Leg Receiver	1 EA	A		1/2" Socket Screw	16 EA
P7		Shelf Platform	1 EA	A1		1-3/16" Socket Screw	2 EA
P8		Back Panel	1 EA	A2		2" Socket Screw	4 EA
P9		Bottom Panel	1 EA	A3		Wood Screw	18 EA
P10		Left Tilt Bracket	1 EA	B		Square Nut	7 EA
P11		Right Tilt Bracket	1 EA	B1		Interior Threaded Post	2 EA
P12		Tilt Support Bar	1 EA	C		Acorn Nut	10 EA
				D		3" Locking Casters	4 EA
				F		Flat Washer	2 EA
				G		Plastic Knob	4 EA
				H		Hinge	2 EA
				J		Allen Wrench	2 EA
				K		Caster Wrench	1 EA
				L		Wrench for acorn nuts	1 EA

Diversity Stand Assembly Diagram

READ THROUGH INSTRUCTIONS FROM BEGINNING TO END BEFORE STARTING TO ASSEMBLE UNIT.

We recommend that you assemble this unit on a table.

- 1.) Identify and Separate all the Parts and Hardware.
- 2.) Place the Shelf Platform (P7) with the insert nuts facing up. Attach 1 each Left Leg Receiver (P5) and 1 each Right Leg Receiver (P6) using 4 each (A) screws.
- 3.) Attach 1 each Back Panel (P8) using 3 each (A) screws as shown in illustration #1. **(Finger tighten only)**

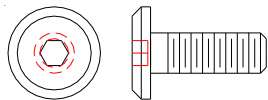

(A) Screw M6 X 1/2"
For Scale only

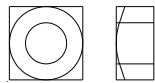

(B) Square Nut M6
For Scale only

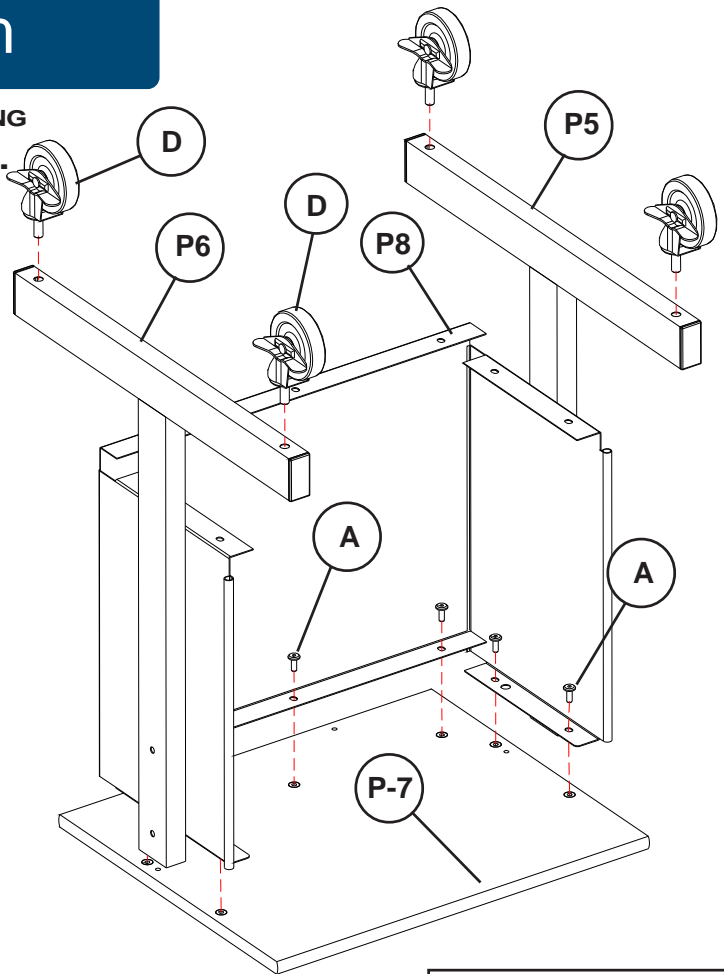

Illustration # 1

- 4.) Attach 4 Locking casters (D) in the front and back as shown in illustration #1. Tighten the Casters using Caster Wrench (K).

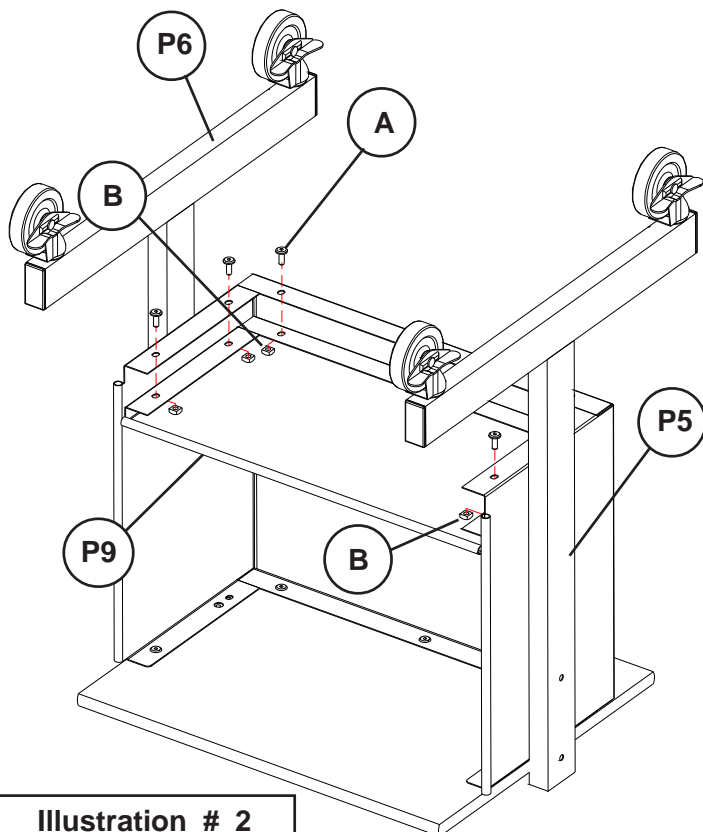
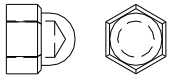

Illustration # 2

- 5.) Attach Bottom Panel (P9) between the Left Leg Receiver (P5) and Right Leg Receiver (P6) using 7 Screws (A) and 7 Square Nuts (B) as shown in illustration #2.

Do not use unless all screws are tight. At least every six months, check all screws to be sure they are tight. If parts are missing, broken, damaged, or worn, stop use of the product until repairs are made by your dealer using factory authorized parts.

6.) Attach Wire Rail (P-13) to the Shelf Platform (P-7) using 4 Acorn Nuts (A4) as shown in illustration #3.



(C) Acorn Nut
For Scale only

Tighten Acorn Nuts (C) using Wrench(L).

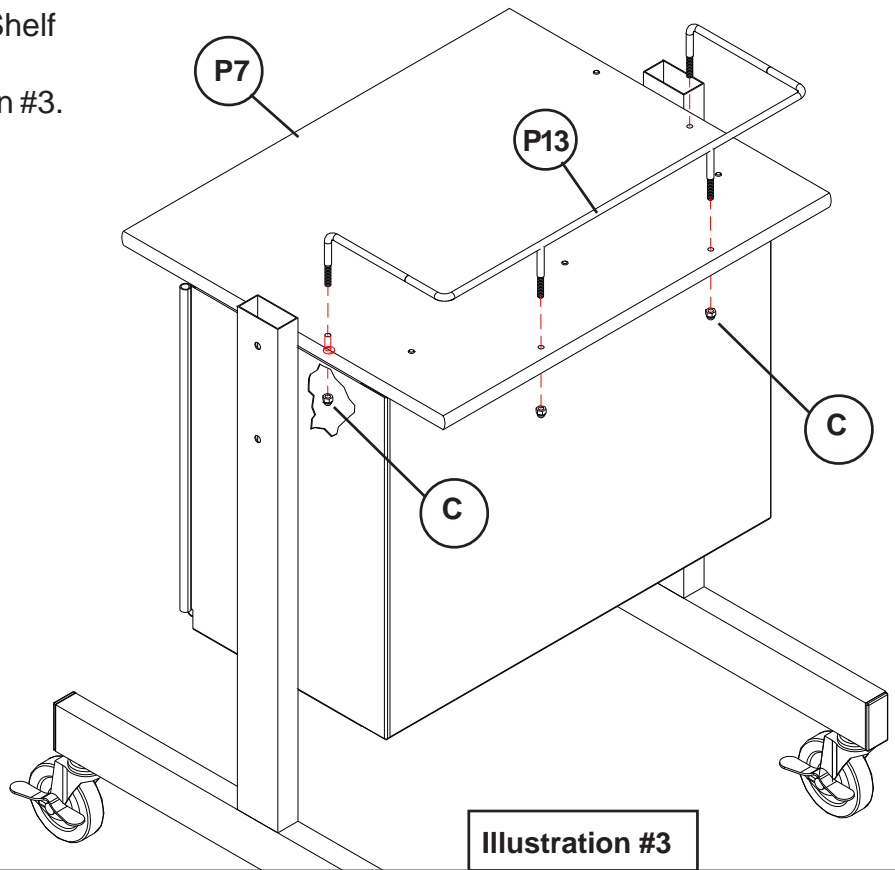
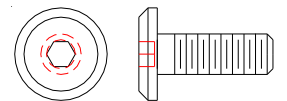

Illustration #3

7.) Attach 2 each Hinges (H) to the LCD Platform (P-1) and the Tilt Platform (P-2) using 12 Screws (A3).

8.) Attach 1 Left Tilt Support Bracket (P-10) and 1 Right Tilt Support Bracket (P-11) to the Tilt Platform (P-2) using 6 Screws (A3) as shown in illustration #4.

9.) Attach Paper Stop (P-16) to the Tilt Platform (P-2) using 2 Screws (A) as shown in illustration #4.



(A) Screw M6 X 1/2"
For Scale only

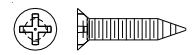

(A3) Screw #4 X 5/8"
For Scale only

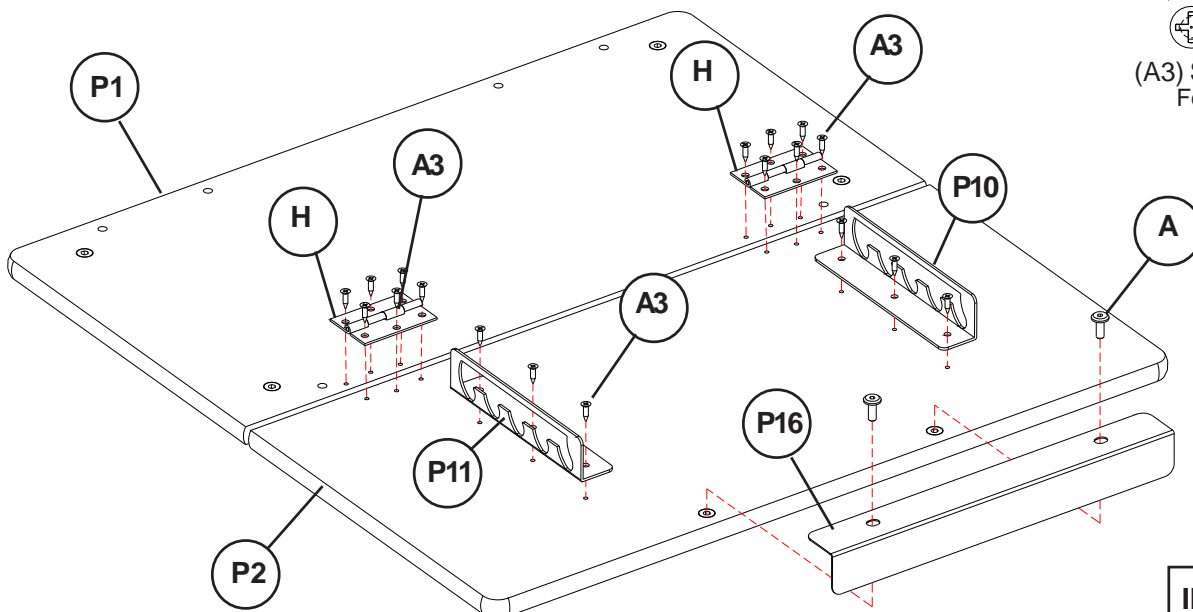
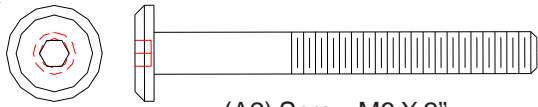
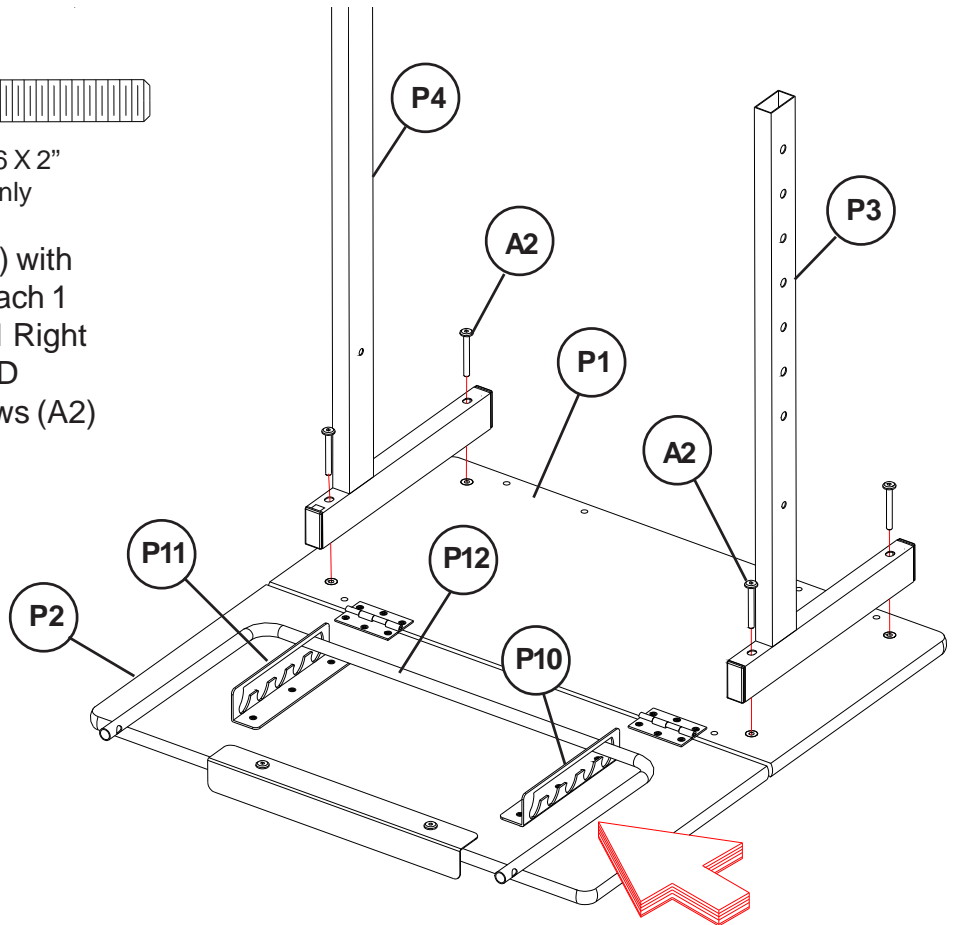

Illustration #4



(A2) Screw M6 X 2"
For Scale only

10.) Place the LCD Platform (P1) with the insert nuts facing up. Attach 1 Left Upper Insert (P-3) and 1 Right Upper Insert (P-4) to the LCD Platform (P-1) using 4 Screws (A2) as shown in illustration #5.



11.) Slide Tilt Support Arm (P-12) through Left Tilt Support Bracket (P-10) and Right Tilt Support Bracket (P-11) as shown in illustration #5.

Illustration #5

12) Rotate Tilt Support Arm (P-12) and attach to 1 Left Upper Insert (P-3) and 1 Right Upper Insert (P-4) using 2 Screws (A1), 2 Flat Washers (F), and 2 Interior Threaded Posts (B1) as shown in illustration #6.

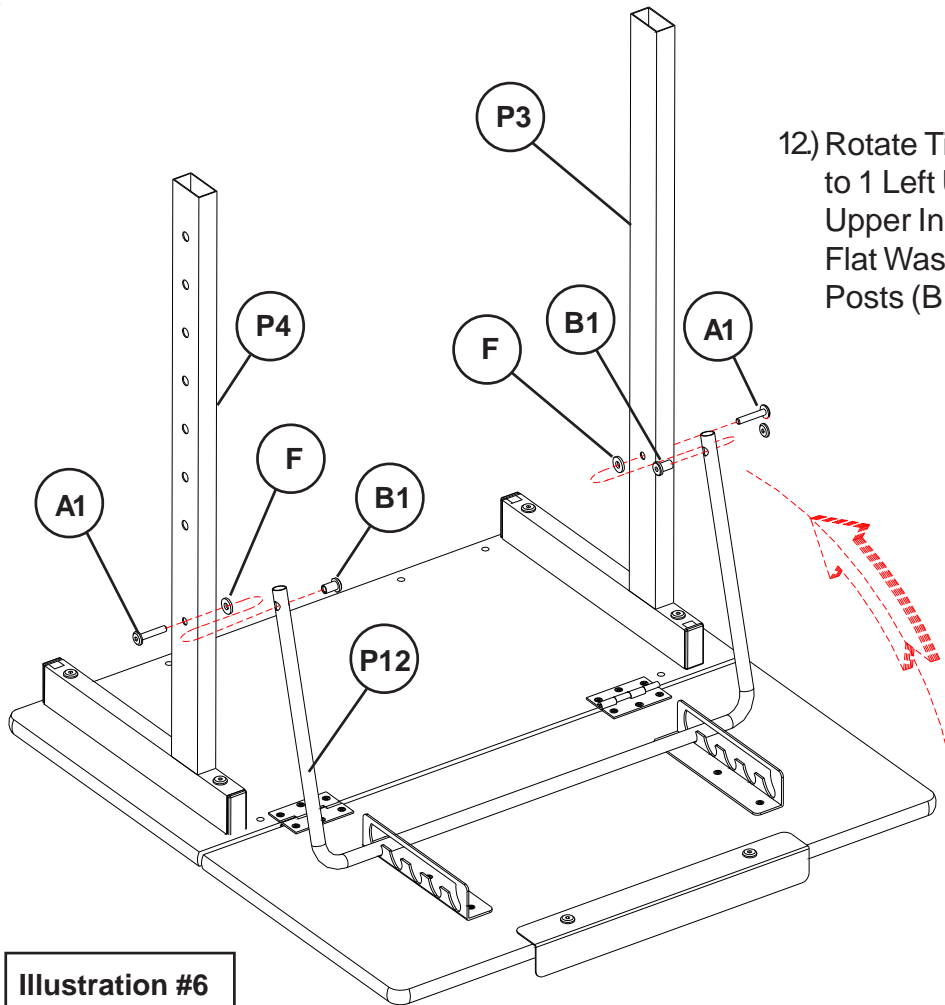

(A1) Screw M6 X 1-1/2"
For Scale only

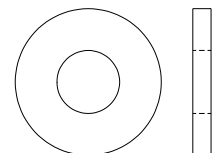

(F) Flat Washer
For Scale only

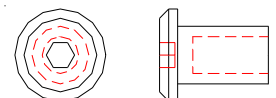

(B1) Interior Threaded Post
M6 X 9/16"
For Scale only

Illustration #6

Missing Parts or UPS Damaged Parts

For Your Convenience you can

EMAIL us at

support@moorecoinc.com

24HOURS 7 DAYS A WEEK

Should you require assistance during assembly,

please call our Customer Service Department

Monday - Friday 8 a.m. - 5 p.m.

Central Standard Time 1-800-749-2258

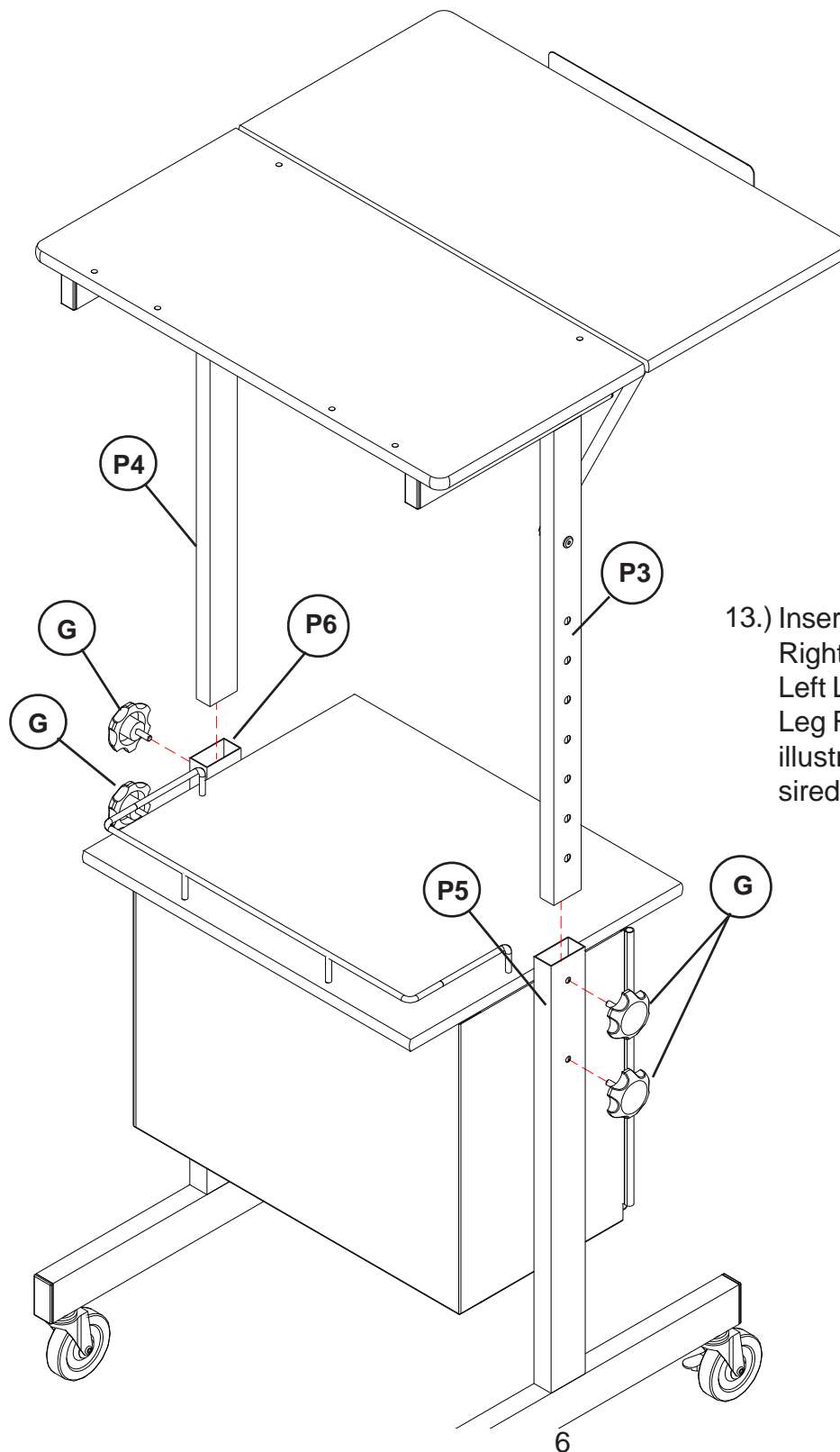

13.) Insert Left Upper Insert (P-3) and Right Upper Insert (P-4) into the Left Leg Receiver (P5) and Right Leg Receiver (P6) as shown in illustration #4. Secure at desired height using 4 Knobs(G)

Illustration #7

14.) Attach 1 wire LCD Front Rail (P10) to the Front of the LCD Platform (P1) using 2 Acorn Nuts (C) as shown in illustration #7.

15.) Attach 2 wire LCD SideRail (P11) to the sides of the LCD Platform (P1) using 4 Acorn (C) as shown in illustration #7.

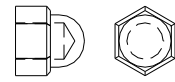

(C) Acorn Nut
For Scale only

Tighten all the screws at this time using Allen Wrench (K).

Tighten Acorn Nuts (C) using Wrench(L).

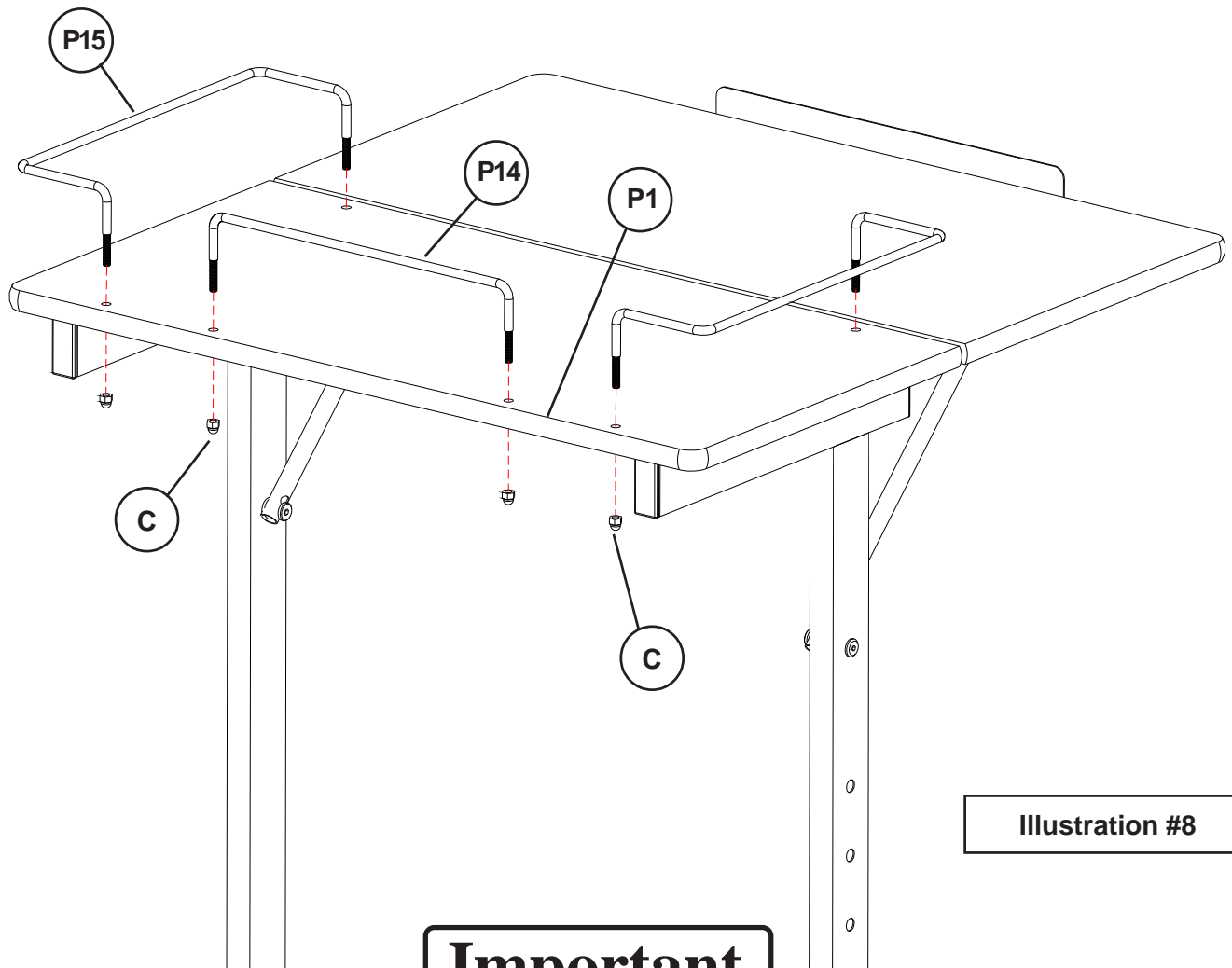

Important

The Balt product you have purchased is guaranteed against material and workmanship defects. This guarantee extends 1 year from date of purchase. Should this product fail to function satisfactorily under normal use due to defect or imperfection, the defective part or product will be replaced. Damage caused by common carriers during shipment is not included in this guarantee.

This guarantee sets forth all applicable guarantees and remedies. No other warranty, expressed or implied shall apply. Failure to follow instructions found in Important Information Section of Owner Sheet shall void the guarantee. Consequential or incidental damages and or costs are not refundable.

#89786 Diversity Stand

Adjustable Height Presentation Center

Touchboards

205 Westwood Ave, Long Branch, NJ 07740
Phone: 866-94 BOARDS (26273) / (732)-222-1511
Fax: (732)-222-7088 | E-mail: sales@touchboards.com

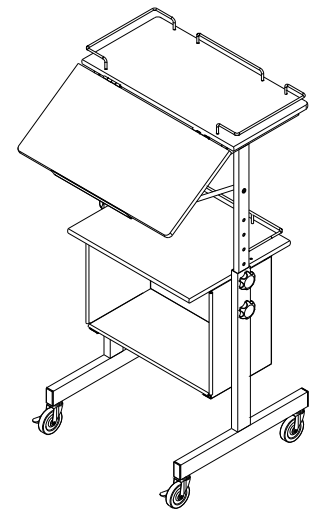
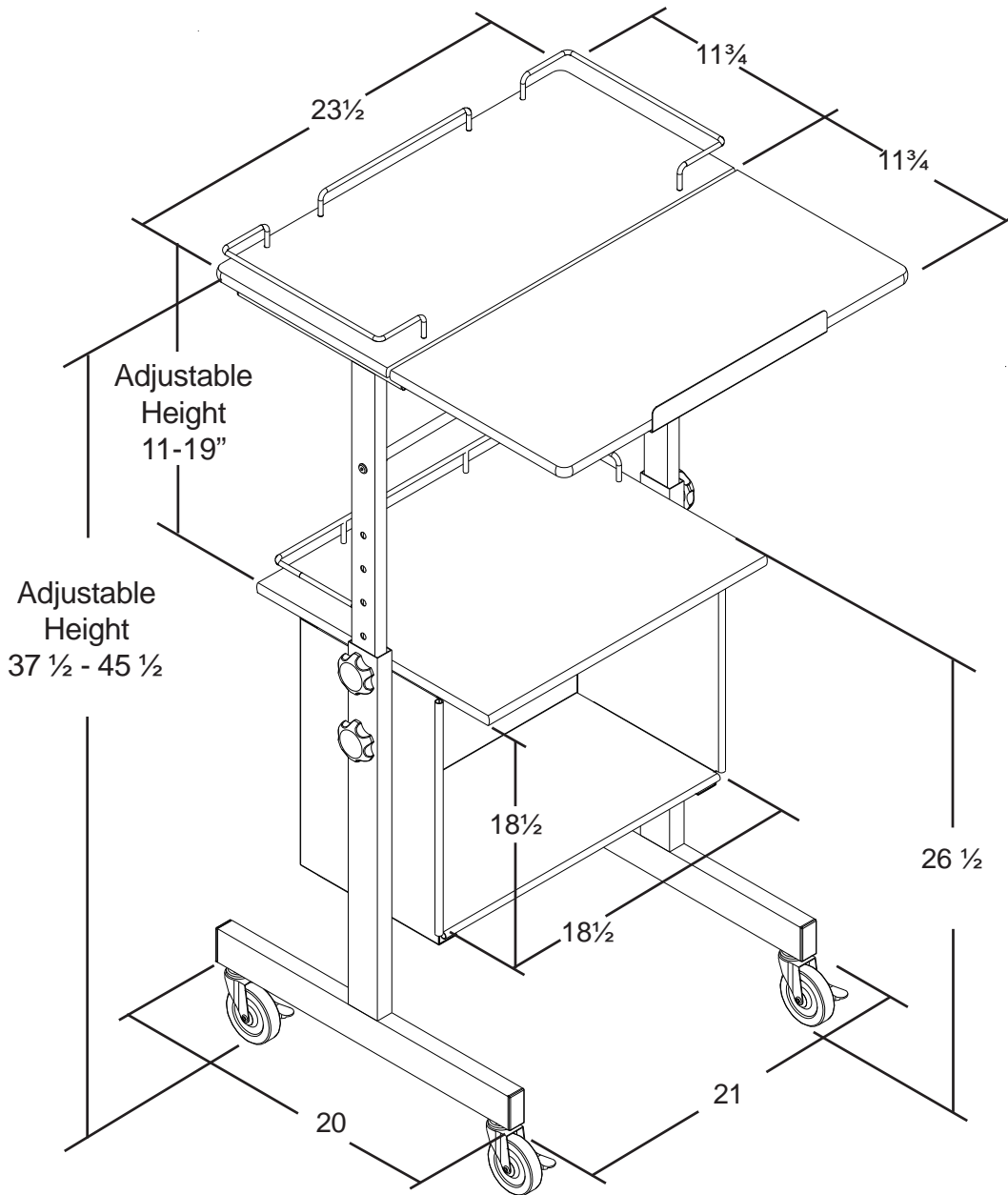

Shipping Information
4.0 Cubic Feet
48 lbs.

