

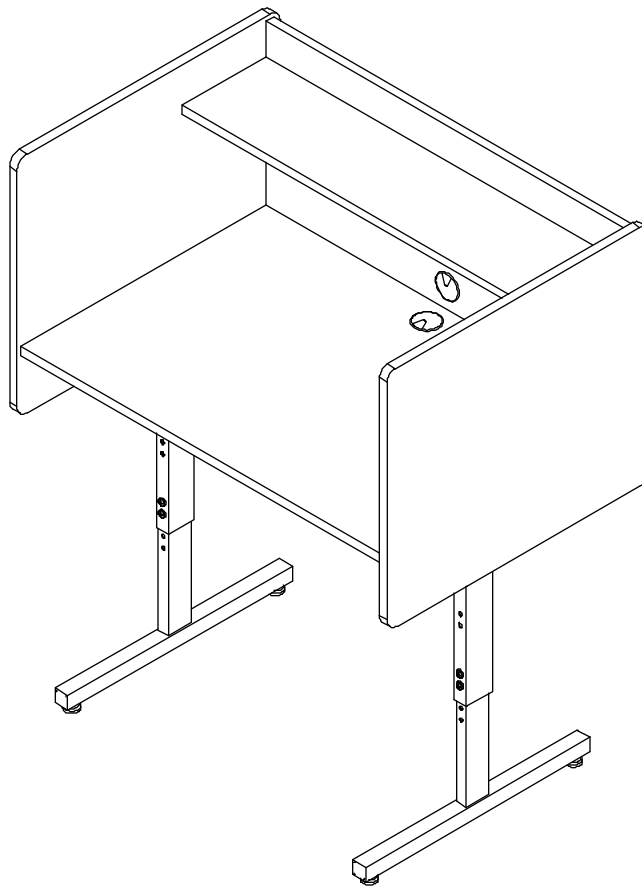

#89788 Study Carrel

Adjustable Height Workcenter













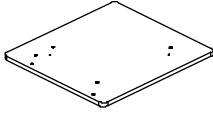
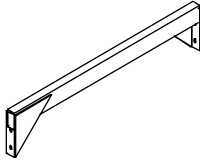
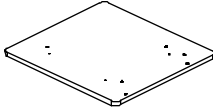

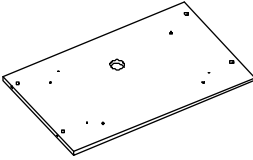

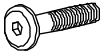





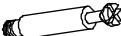

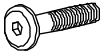

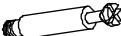

Touchboards

205 Westwood Ave, Long Branch, NJ 07740
Phone: 866-94 BOARDS (26273) / (732)-222-1511
Fax: (732)-222-7088 | E-mail: sales@touchboards.com

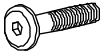
Assembly Instructions

Study Carrel

Adjustable Height Workcenter

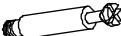
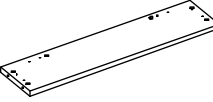
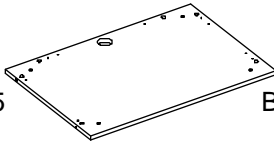
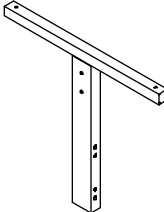
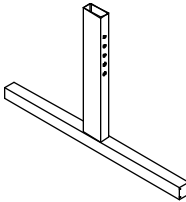
Part	Drawing	Description	Qty	Part	Drawing	Description	Qty																																				
P1		Right Side Panel	1 EA	P8		Stability Brace	1 EA																																				
P2		Left Side Panel	1 EA	P9		Metal Angle Bracket	8 EA																																				
P3		Top Platform	1 EA	<div style="border: 1px solid black; border-radius: 15px; padding: 10px;"> <p style="text-align: center;">Hardware List</p> <table border="0"> <tr> <td>A</td> <td></td> <td>1/2" Socket Screw</td> <td>4 EA</td> </tr> <tr> <td>A1</td> <td></td> <td>1-1/2" Socket Screw</td> <td>8 EA</td> </tr> <tr> <td>B</td> <td></td> <td>Threaded Nut</td> <td>4 EA</td> </tr> <tr> <td>C</td> <td></td> <td>Wood Screw</td> <td>24 EA</td> </tr> <tr> <td>D</td> <td></td> <td>Plastic Grommet</td> <td>2 EA</td> </tr> <tr> <td>E</td> <td></td> <td>Leveling Glide</td> <td>4 EA</td> </tr> <tr> <td>F</td> <td></td> <td>Allen Wrench</td> <td>1 EA</td> </tr> <tr> <td>G</td> <td></td> <td>Cam Lock</td> <td>16 EA</td> </tr> <tr> <td>H</td> <td></td> <td>Cam Post</td> <td>16 EA</td> </tr> </table> </div>				A		1/2" Socket Screw	4 EA	A1		1-1/2" Socket Screw	8 EA	B		Threaded Nut	4 EA	C		Wood Screw	24 EA	D		Plastic Grommet	2 EA	E		Leveling Glide	4 EA	F		Allen Wrench	1 EA	G		Cam Lock	16 EA	H		Cam Post	16 EA
A		1/2" Socket Screw	4 EA																																								
A1		1-1/2" Socket Screw	8 EA																																								
B		Threaded Nut	4 EA																																								
C		Wood Screw	24 EA																																								
D		Plastic Grommet	2 EA																																								
E		Leveling Glide	4 EA																																								
F		Allen Wrench	1 EA																																								
G		Cam Lock	16 EA																																								
H		Cam Post	16 EA																																								
P4		Upper Shelf Platform	1 EA																																								
P5		Back Panel	1 EA																																								
P6		Upper Leg Receiver	2 EA																																								
P7		Lower Leg Insert	2 EA																																								

We recommend that you assemble this unit on a table.

Tools required: Adjustable Crescent Wrench

Missing Parts or UPS Damaged Parts

For Your Convenience you can
EMAIL us at
furniture@baltinc.com
24HOURS 7 DAYS A WEEK

***Should you require assistance during assembly,
please call our Customer Service Department
Monday - Friday 8 a.m. - 5 p.m.
Central Standard Time 1-800-749-2258***

Do not use unless all screws are tight. At least every six months, check all screws to be sure they are tight. If parts are missing, broken, damaged, or worn, stop use of the product until repairs are made by your dealer using factory authorized parts.

Study Carrel Assembly Diagram



READ THROUGH INSTRUCTIONS FROM BEGINNING TO END BEFORE STARTING TO ASSEMBLE UNIT.

- 1.) Identify and Separate all the Parts and Hardware.

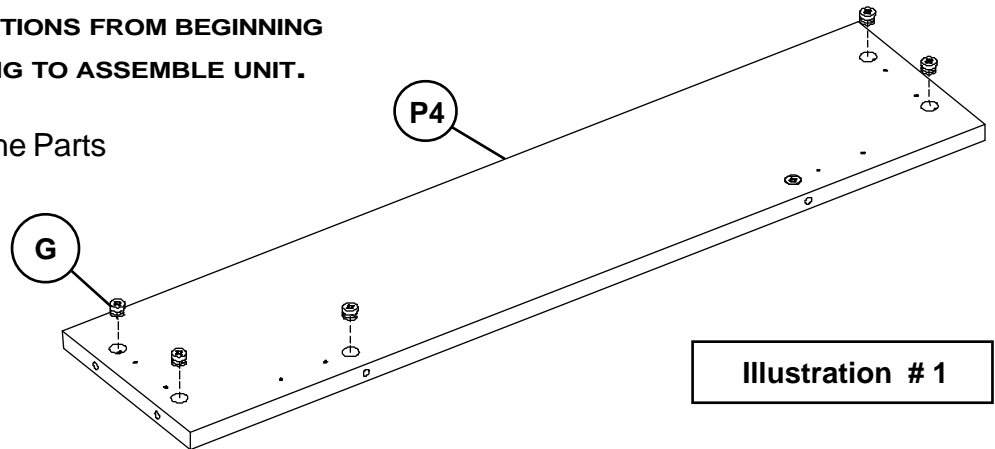
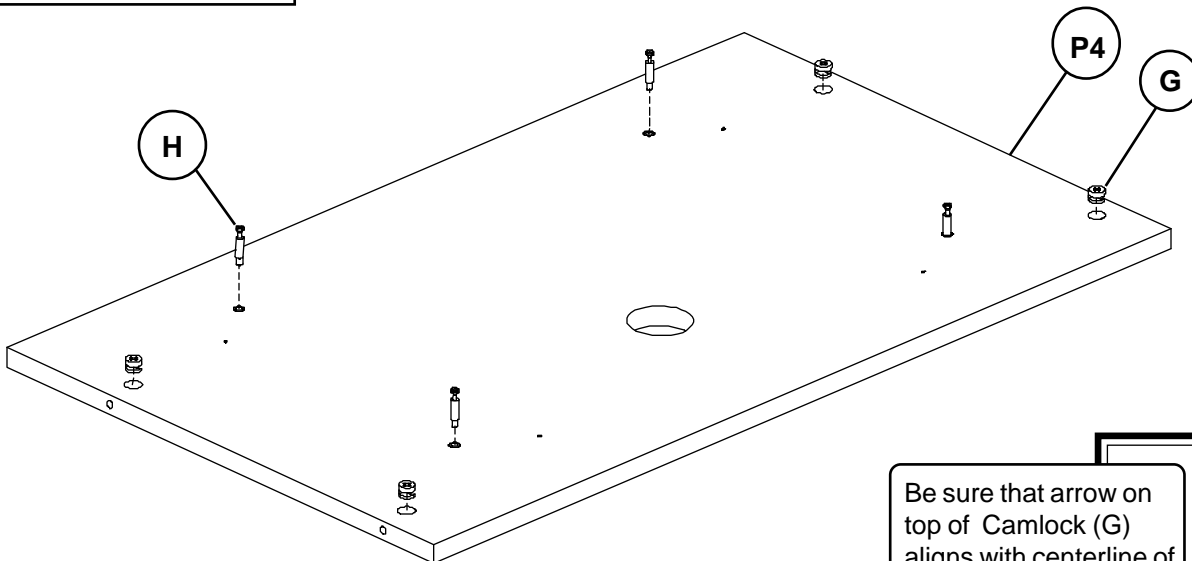

Illustration # 1

- 2.) Place the Upper Shelf Platform (P4) with the Holes facing up and install 6 each Cam Locks (G) into the large holes as shown in illustration # 1.

Illustration # 2



Be sure that arrow on top of Camlock (G) aligns with centerline of Edge Drilled hole.

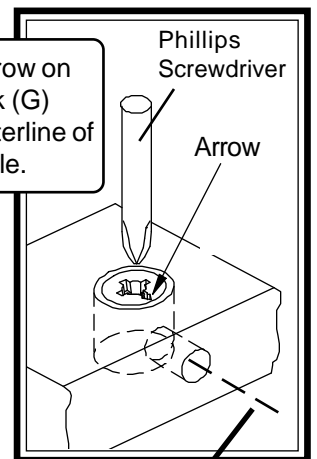

Centerline of Edge Drilled hole.

- 3.) Place the Back Panel (P5) with the insert nuts facing up and install 4 each Cam Locks (G) into the large holes as shown in illustration # 2.
- 4.) Install 4 each Cam Posts (H) in the 4 threaded insert nuts (Pre-installed) as shown in illustration # 2.

5.) Place the Left Side Panel (P2) with the insert nuts facing up.

6.) Install 6 each Cam Posts (H) in the 6 threaded insert nuts (Pre-installed) as shown in illustration # 3.

7.) Repeat Steps 5 & 6 for the Right Side Panel(P6).

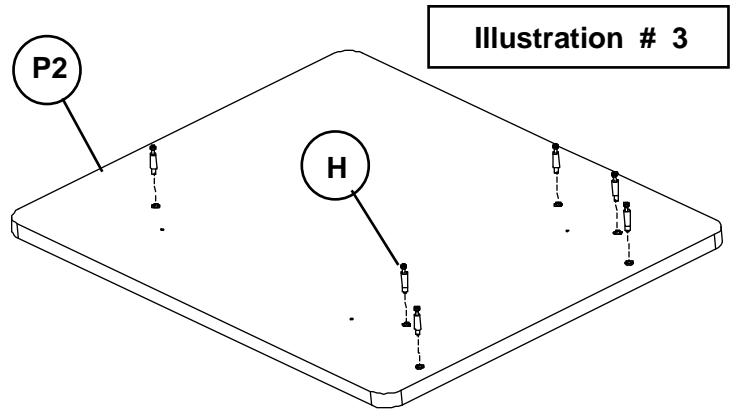

Illustration # 3

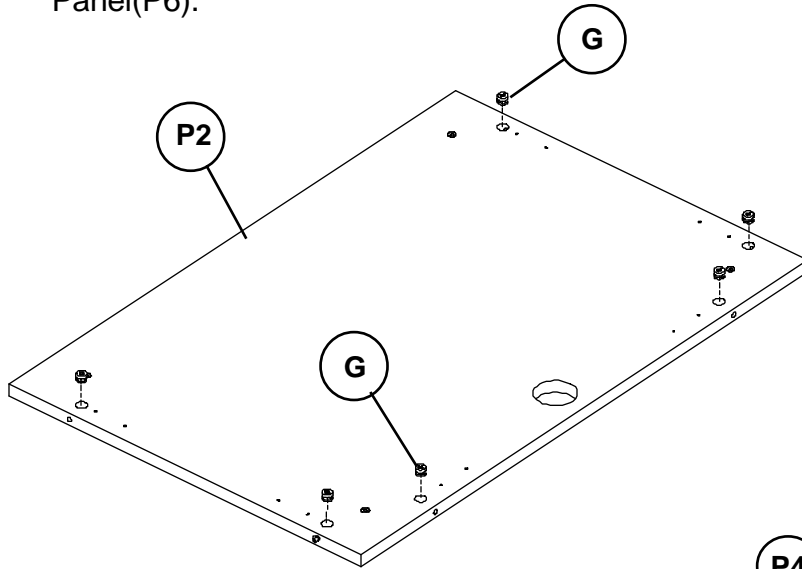

Illustration # 4

8.) Place the Top Platform (P3) with the Holes facing up and install 6 each Cam Locks (G) into the large holes as shown in illustration # 4.

9.) Place the Back Panel (P5) with the insert nuts facing up. Slide 1 each Upper Shelf Platform (P4) over the Cam Posts (H) as shown in illustration # 5. Secure by turning the Cam Locks (H) 1/4 Turn until they lock.

10.) Slide 1 each Top Platform (P3) over the Cam Posts (H) as shown in illustration #5 and secure by turning the Cam Locks (H) 1/4 Turn until they lock. **(Finger tighten only)**

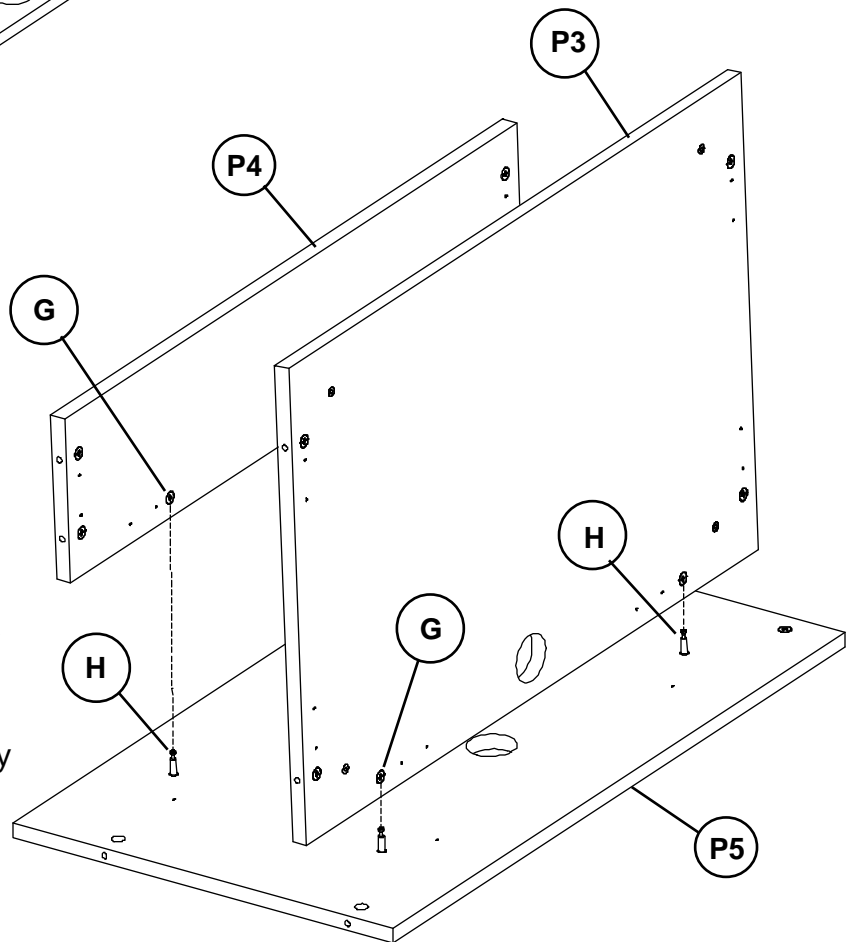
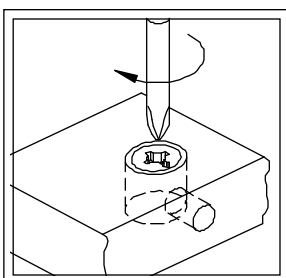
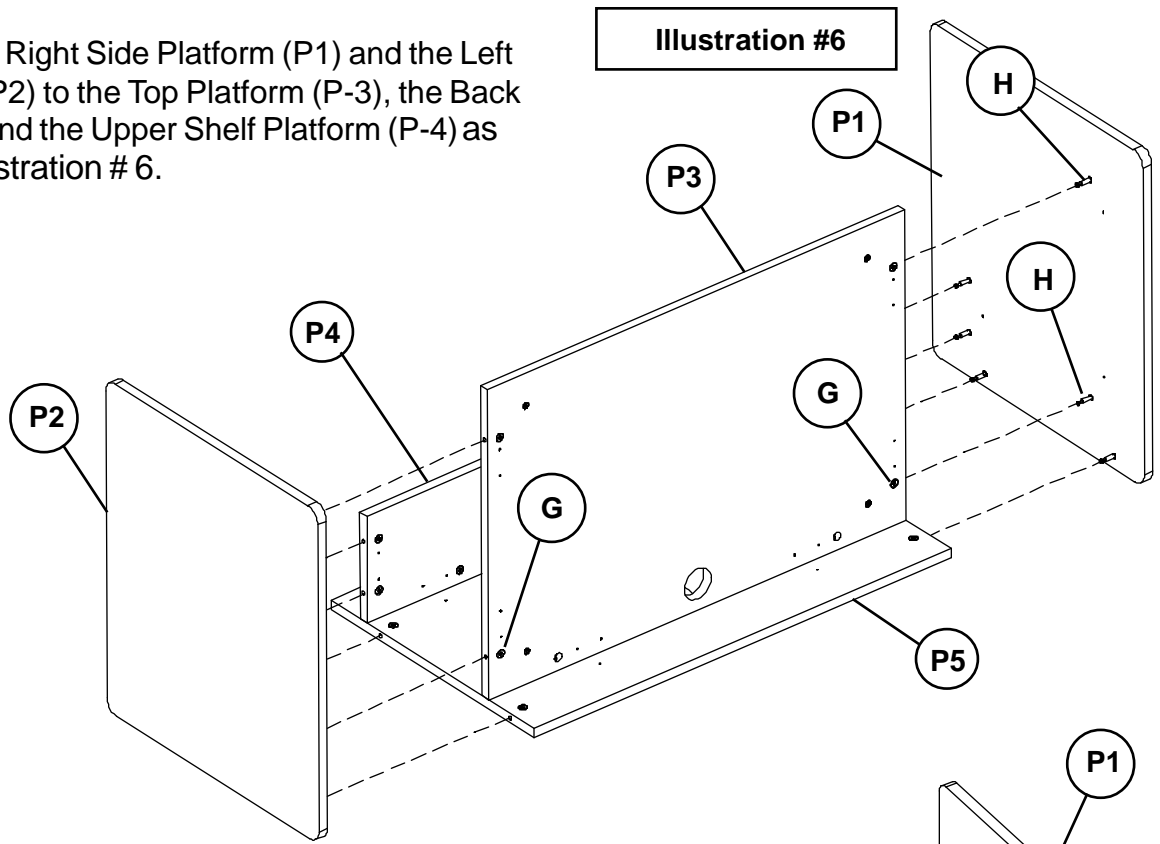

Illustration # 5



To Secure Cam Locks, Insert Large Phillips Head Screwdriver and turn Cam Lock 1/4 turn (90 degrees) clockwise.

11.) Attach to the Right Side Platform (P1) and the Left Side Panel (P2) to the Top Platform (P-3), the Back Panel (P5), and the Upper Shelf Platform (P-4) as shown in illustration # 6.



12.) Attach 6 each Metal Angle Brackets (P9) using 18 each (C) screws as shown in illustration # 7.

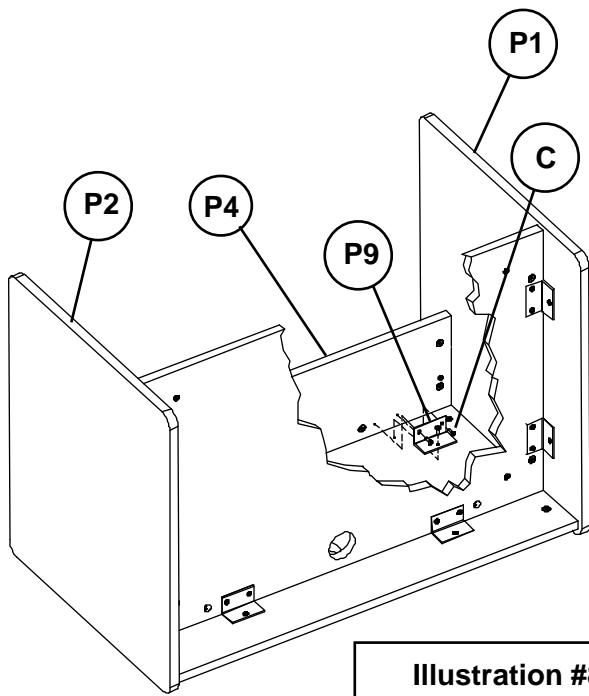
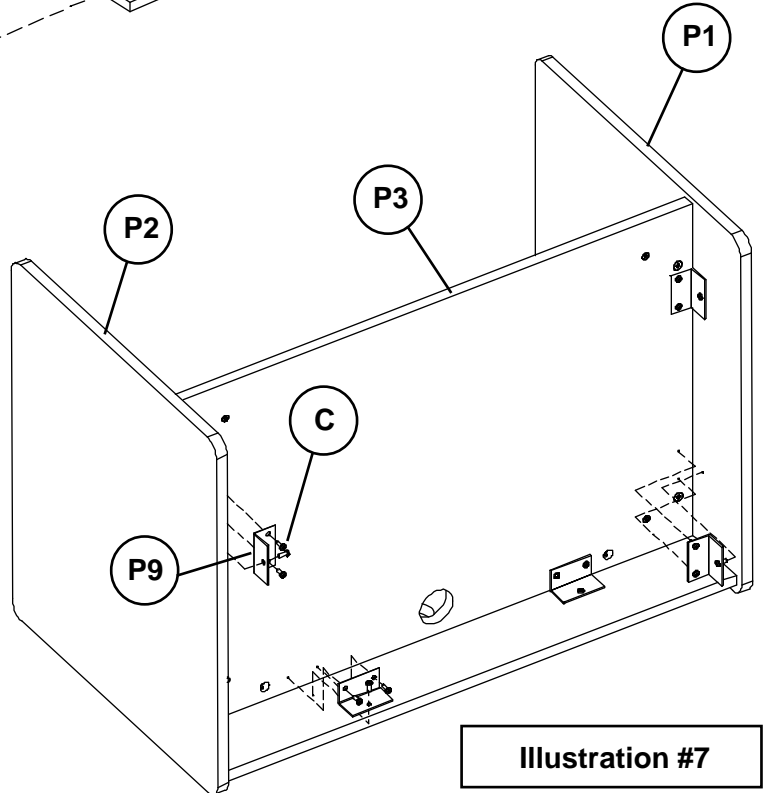
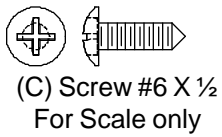

13.) Attach 2 each Metal Angle Brackets (P9) using 6 each (C) screws as shown in illustration # 8.

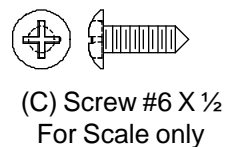

- 14) Rotate the Carrel Assembly so that the Bottom Platform (P-3) is facing up. Attach 2 each Upper Receivers (P6) to the Bottom Platform (P-3) using 4 each (A1) screws as shown in illustration #9.
(Finger tighten only)

- 15.) Attach Stability Brace (P8) to the 2 each Upper Receivers (P6) using 4 Screws (A1) and 4 Threaded Nuts (B) as shown in illustration #6.

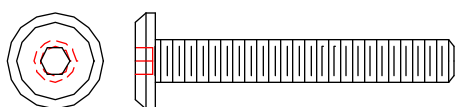

(A1) Screw M6 X 1-1/2"
For Scale only

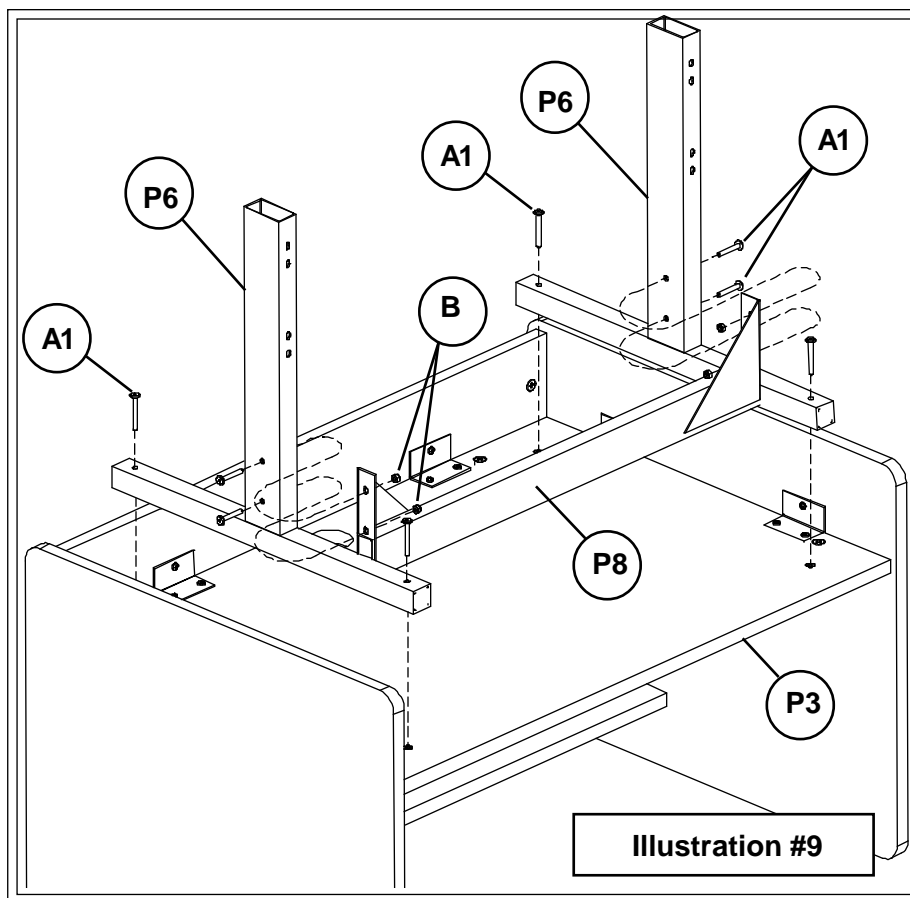
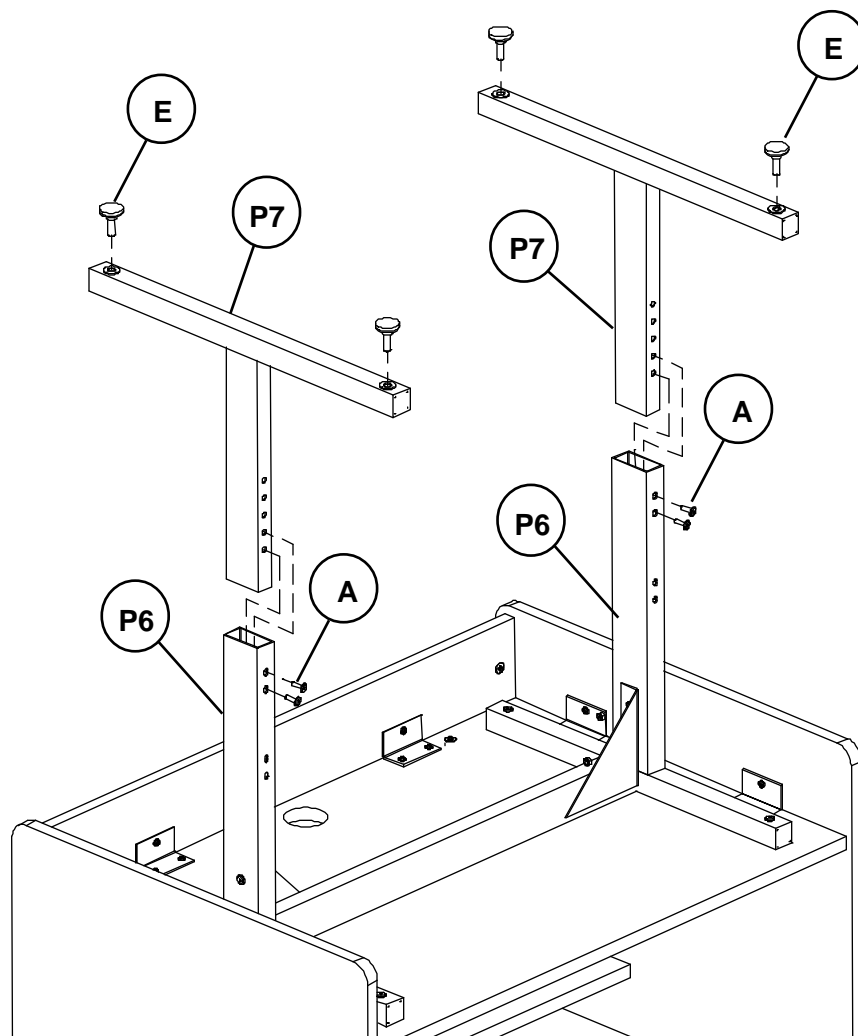

Illustration #9



- 16.) Slide 2 Lower Leg Inserts (P7) into the Upper Leg Receivers (P6). Secure at desired height using (4) each (A) Screws as shown in illustration #10.

(Tighten all the screws at this time using Allen Wrench (F)).

- 17.) Attach 4 each (E) Leveling Glides to the 2 each Lower Leg Inserts (P7).

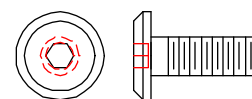

(C) Screw M6 X 9/16"
For Scale only

Illustration #10

**Grommet(D) installation
Illustration #11**

- 18.) To install Grommet (D), separate parts and press Grommet Sleeve in Round openings in Bottom Platform (P3) and Back Panel (P4) as shown in illustration #8.
- 19.) Snap plastic Caps into Sleeves as shown in illustration #11.

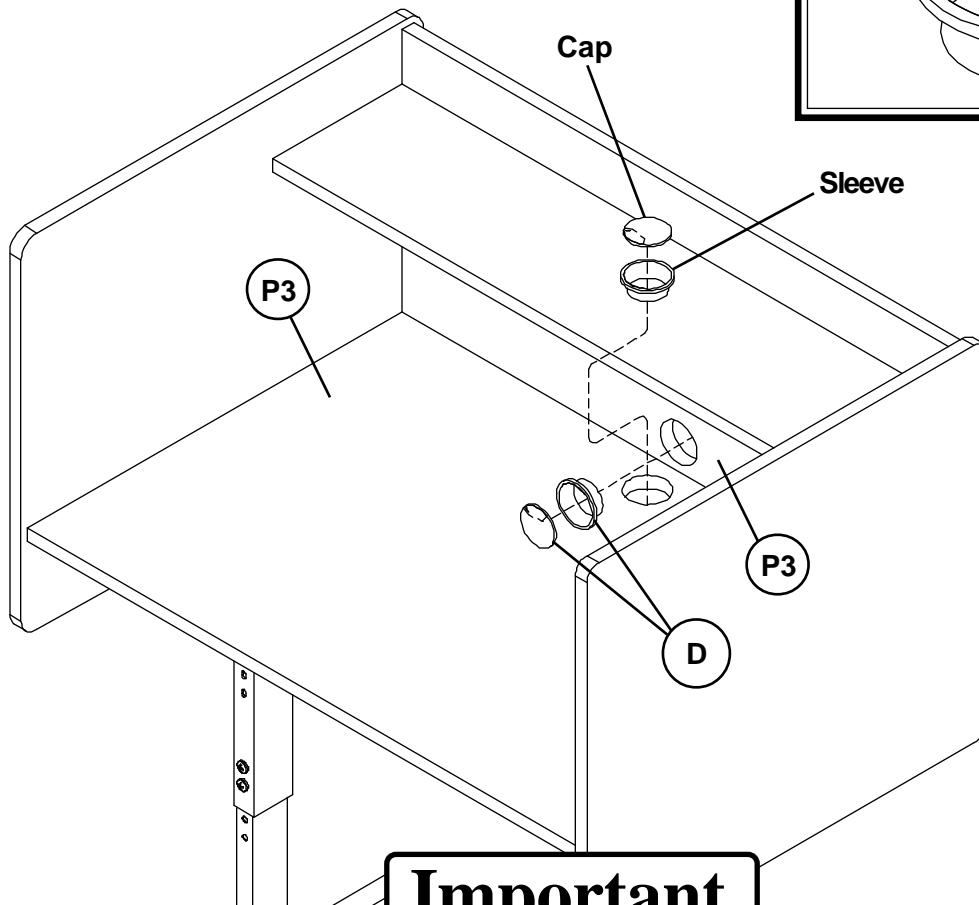
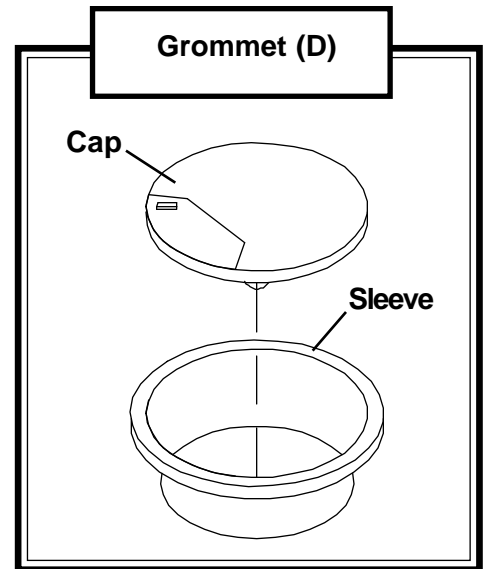

Important

The Balt product you have purchased is guaranteed against material and workmanship defects. This guarantee extends 1 year from date of purchase. Should this product fail to function satisfactorily under normal use due to defect or imperfection, the defective part or product will be replaced. Damage caused by common carriers during shipment is not included in this guarantee.

This guarantee sets forth all applicable guarantees and remedies. No other warranty, expressed or implied shall apply. Failure to follow instructions found in Important Information Section of Owner Sheet shall void the guarantee. Consequential or incidental damages and or costs are not refundable.

89788-Study Carrel Workcenter



For more information
1-800-749-2258

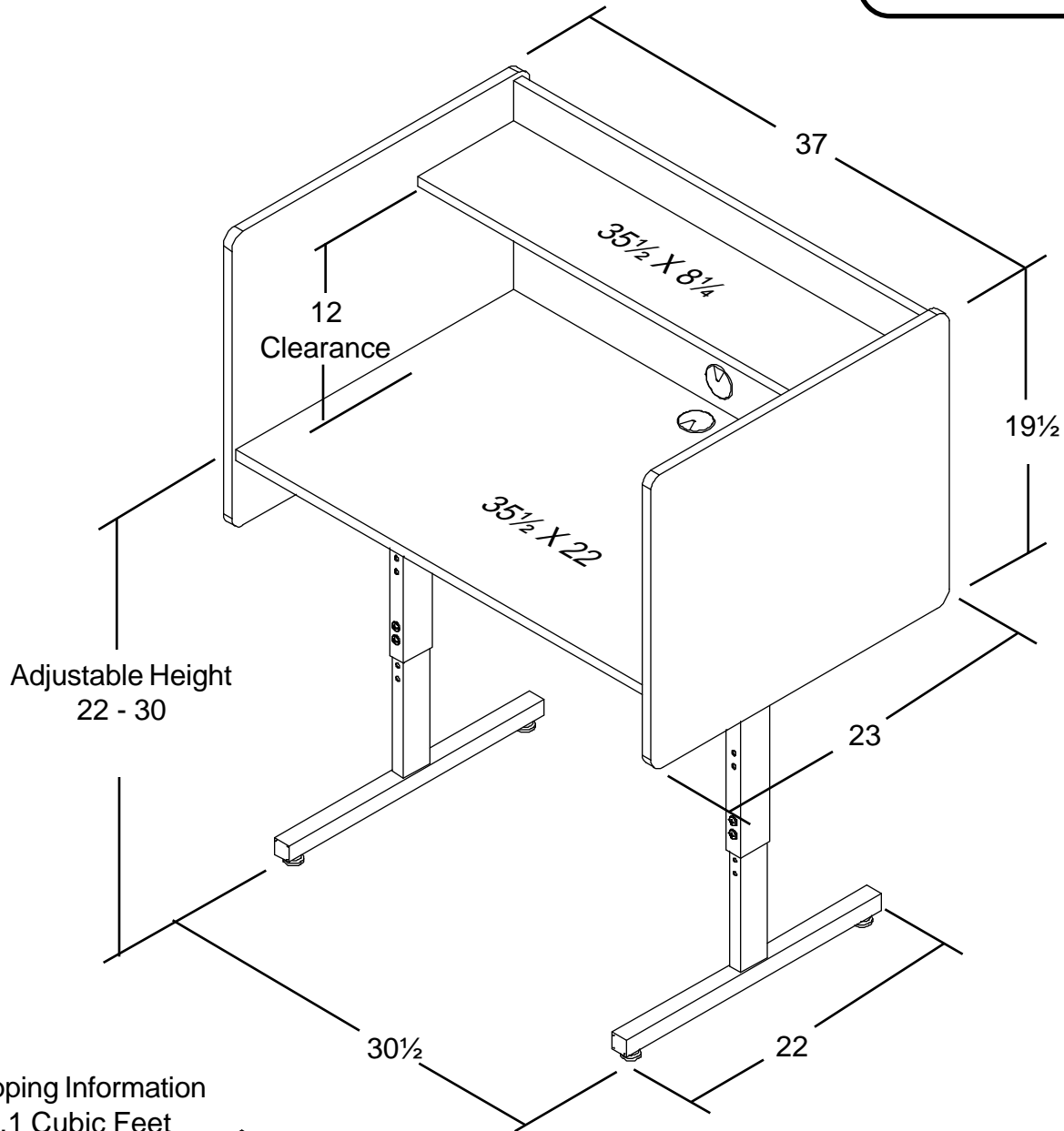

Shipping Information
5.1 Cubic Feet
92 lbs.

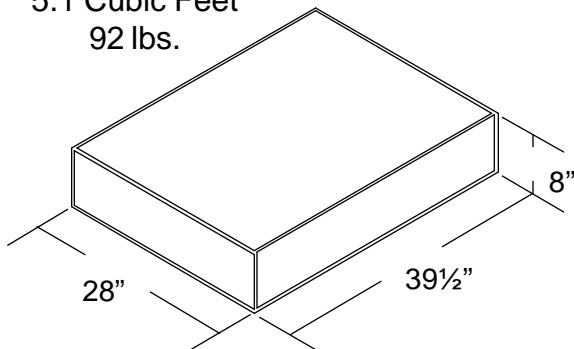

205 Westwood Ave, Long Branch, NJ 07740
Phone: 866-94 BOARDS (26273) / (732)-222-1511
Fax: (732)-222-7088 | E-mail: sales@touchboards.com