



Agility Tables

89959, 89960, 89961, 89962



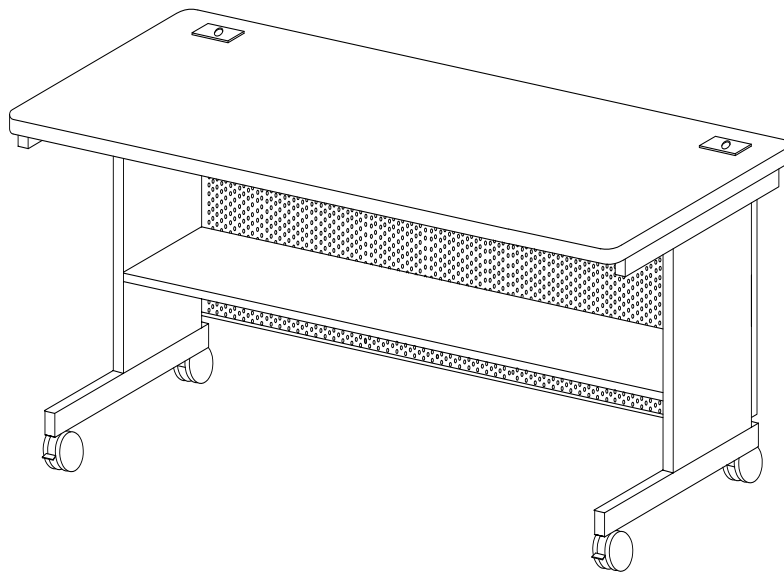

Touchboards

205 Westwood Ave, Long Branch, NJ 07740
Phone: 866-94 BOARDS (26273) / (732)-222-1511
Fax: (732)-222-7088 | E-mail: sales@touchboards.com

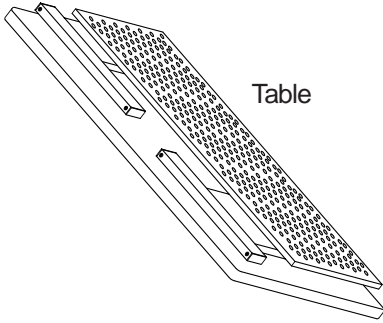

Assembly Instructions

Agility Tables #89959, 89960, 89961, 89962

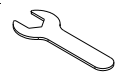
Part	Drawing	Description	Qty	Part	Drawing	Description	Qty
P1		Table	1 EA	Hardware List			
				A		Locking Caster	2 EA
				B		Non-Locking Caster	2 EA
				C		Thumb Screw	2 EA
				D		Caster Wrench	1 EA

Important

The Balt product you have purchased is guaranteed against material and workmanship defects. This guarantee extends 1 year from date of purchase. Should this product fail to function satisfactorily under normal use due to defect or imperfection, the defective part or product will be replaced. Damage caused by common carriers during shipment is not included in this guarantee.

This guarantee sets forth all applicable guarantees and remedies. No other warranty, expressed or implied shall apply. Failure to follow instructions found in Important Information Section of Owner Sheet shall void the guarantee. Consequential or incidental damages and or costs are not refundable.

Missing Parts or UPS Damaged Parts

For Your Convenience you can
EMAIL us at
furniture@baltinc.com
24HOURS 7 DAYS A WEEK

***Should you require assistance during assembly,
please call our Customer Service Department
Monday - Friday 8 a.m. - 5 p.m.
Central Standard Time 1-800-749-2258***

Do not use unless all screws are tight. At least every six months, check all screws to be sure they are tight. If parts are missing, broken, damaged, or worn, stop use of the product until repairs are made by your dealer using factory authorized parts.

Agility Table Assembly Diagram

READ THROUGH INSTRUCTIONS FROM BEGINNING TO END BEFORE STARTING TO ASSEMBLE UNIT.

- 1.) Identify and Separate all the Parts and Hardware.
- 2.) Lay Table Top (P-1) on Smooth surface as shown in illustration #1.

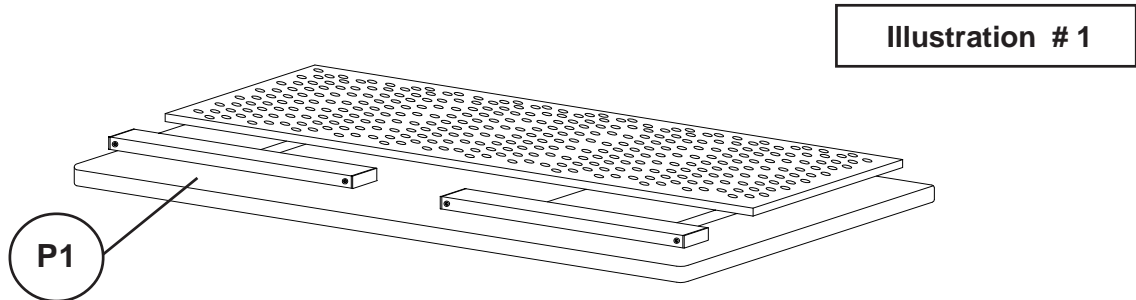

- 3.) Lift the legs, shelf and back panel assembly up vertical to the table top as shown in Illustration #2.

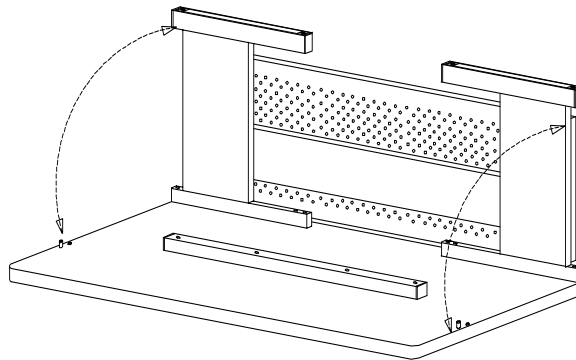

- 4.) Swivel the legs out and place them over the two locator posts that are attached to the bottom of the table top as shown in Illustration #3. Secure the leg to the table top using two Thumb Screws (C).

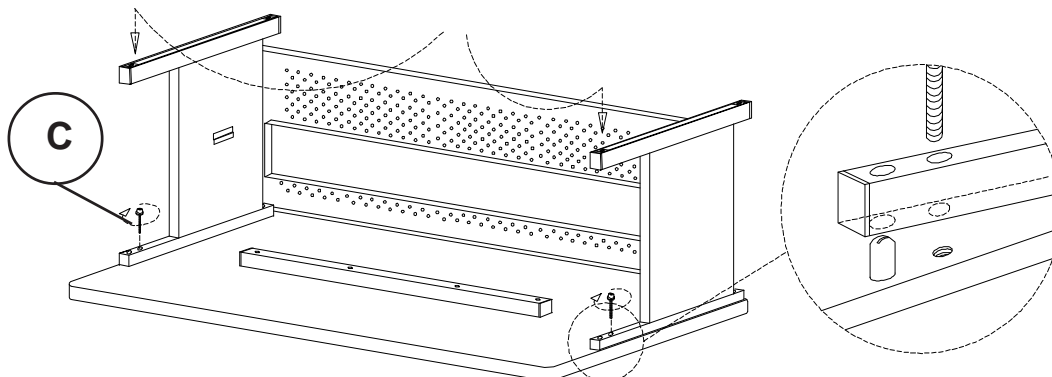

5.) Screw in two Locking Casters (A) into the front threaded inserts in the legs as shown in Illustration #4. Screw in two Non-Locking Casters (B) into the rear threaded inserts. Tighten casters using Caster Wrench (D).

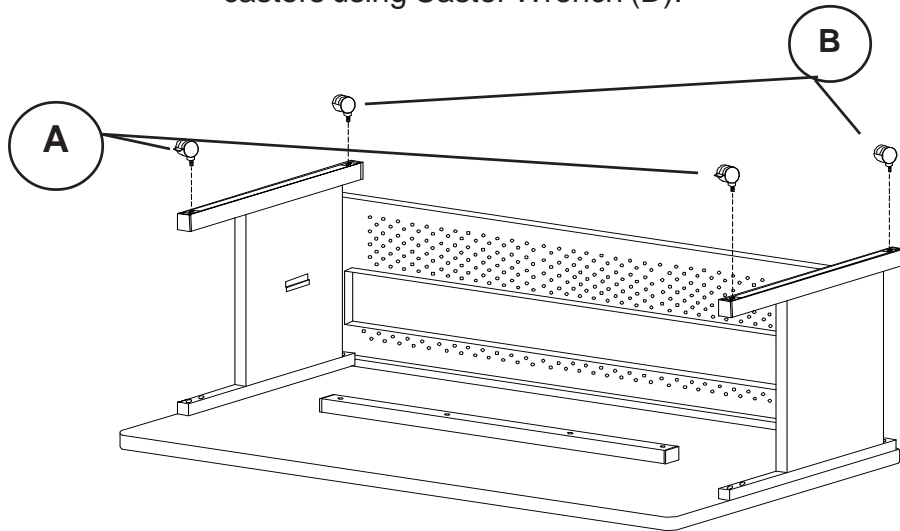

Illustration # 4

6.) Fold the shelf panel down and hook it on the shelf support tabs on each leg as shown in Illustration #5.

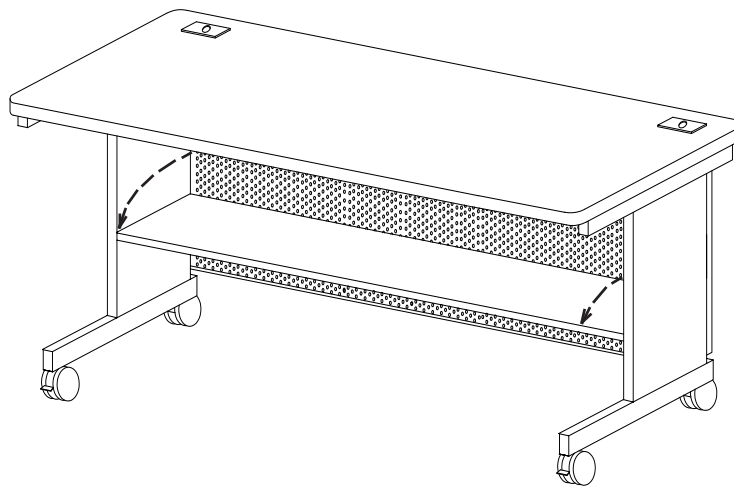

Illustration # 5

Touchboards

205 Westwood Ave, Long Branch, NJ 07740
Phone: 866-94 BOARDS (26273) / (732)-222-1511
Fax: (732)-222-7088 | E-mail: sales@touchboards.com