

# Touchboards

205 Westwood Ave, Long Branch, NJ 07740  
Phone: 866-94 BOARDS (26273) / (732)-222-1511  
Fax: (732)-222-7088 | E-mail: sales@touchboards.com

## Get Up Stand Up™ 90459

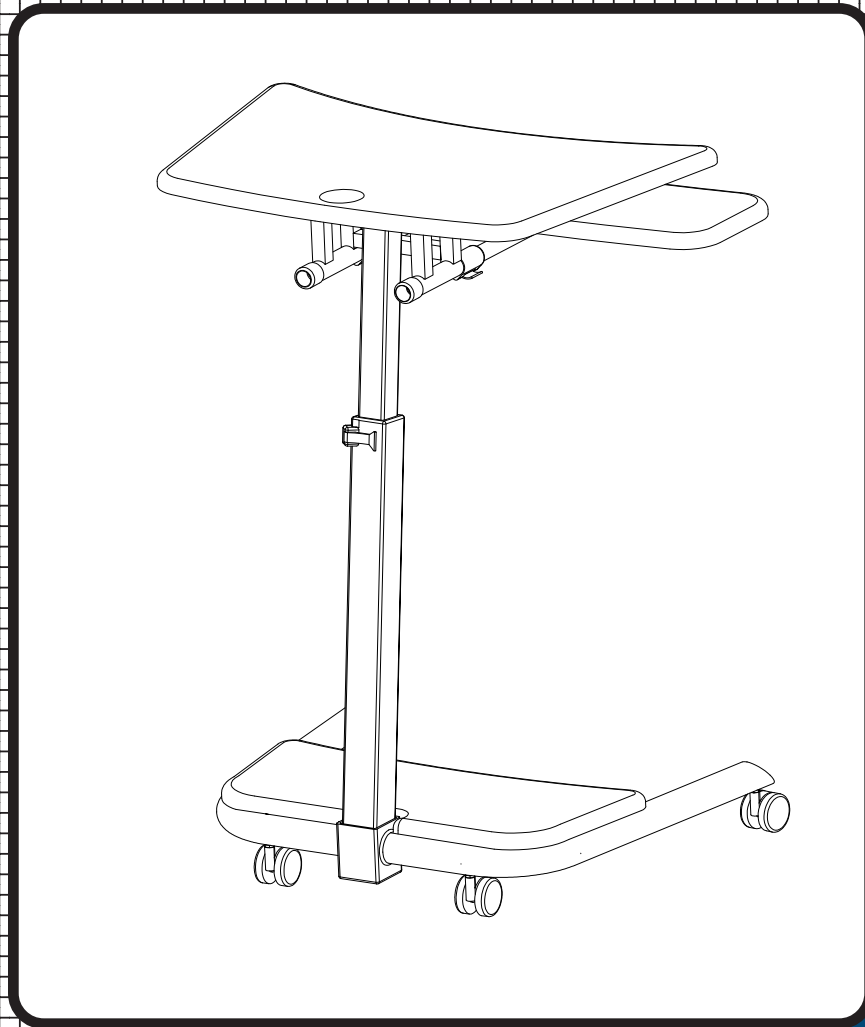









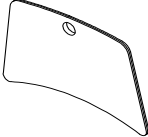

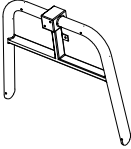
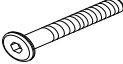
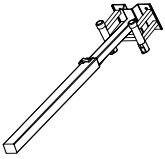

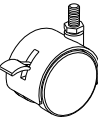
### Up-Rite 500 Height Adjustable Standing Desk

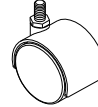
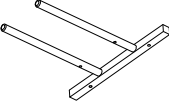

# Assembly Instructions

## Parts List

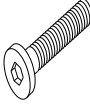
## Hardware List

Part	Drawing	Description	Qty	Drawing	Description	Qty
P-1		Top Panel	1 EA	A	 Screw M6*12mm	4 EA
P-2		Base	1 EA	B	 Screw M6*38mm	4 EA
P-3		Pneumatic Post	1 EA	C	 Screw M8*25mm	4 EA
P-4		Keyboard Shelf	1 EA	D	 2" Locking Casters (for Front)	2 EA
P-5		Bottom Shelf	1 EA	E	 2" Casters (for Back)	2 EA
P-6		Keyboard Support	1 EA	F	 Allen Wrench	1 EA
				G	 Caster Wrench	1 EA
				H	 Spacer	4 EA
				I	 Grommet	1 EA
				J	 Phillips Screw	2 EA
				K	 Screw M6*25mm	2 EA
				L	 Large Washer	2 EA

### Important Information:

Do not use unless all screws are tight. At least every six months, check all screws to be sure they are tight. If parts are missing, broken, damaged, or worn, stop use of the product until repairs are made by your dealer using factory authorized parts.

# Assembly Diagram

1.) Identify and separate all the Parts and Hardware.

2.) Screw in two Locking Casters (D) into the front holes in the bottom of the Base (P2) as shown in illustration #1. Screw in two Non-Locking Casters (E) into the rear holes on the bottom of the Base. Tighten Casters using Caster Wrench (G).

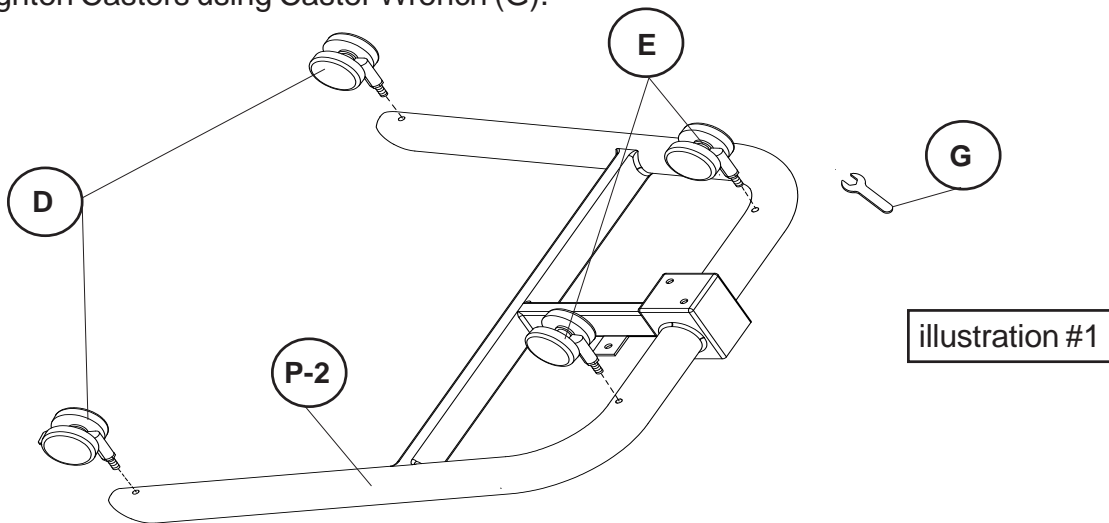

illustration #1

3.) Insert the bottom of the Pneumatic Post (P3) in to the square recess in the Base (P2) and secure using two Screws (C). Tighten Screws with Allen Wrench (F) as shown in illustration #2.

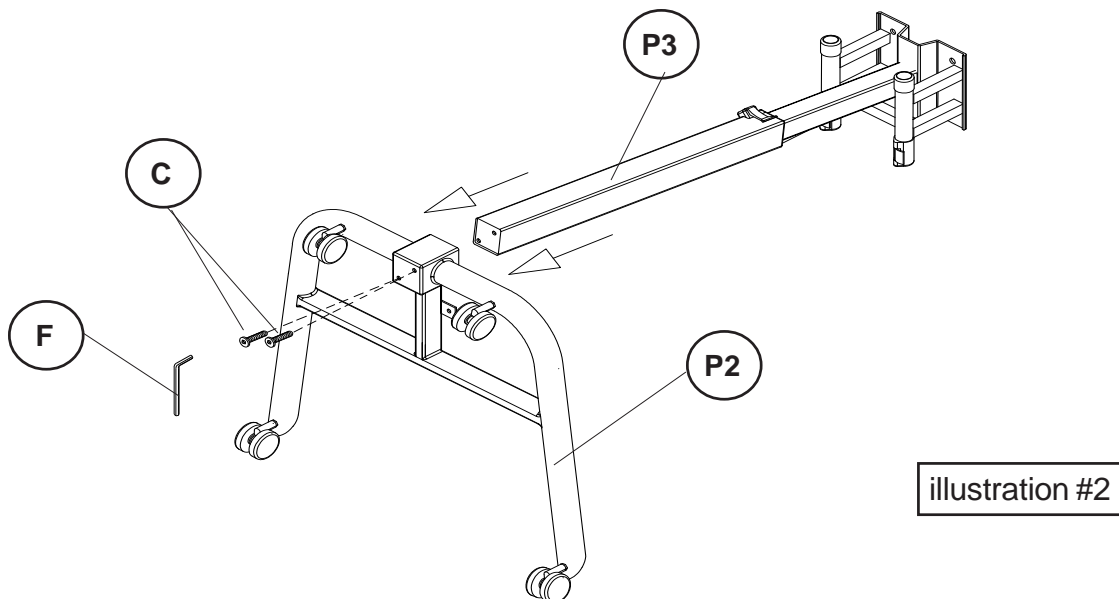
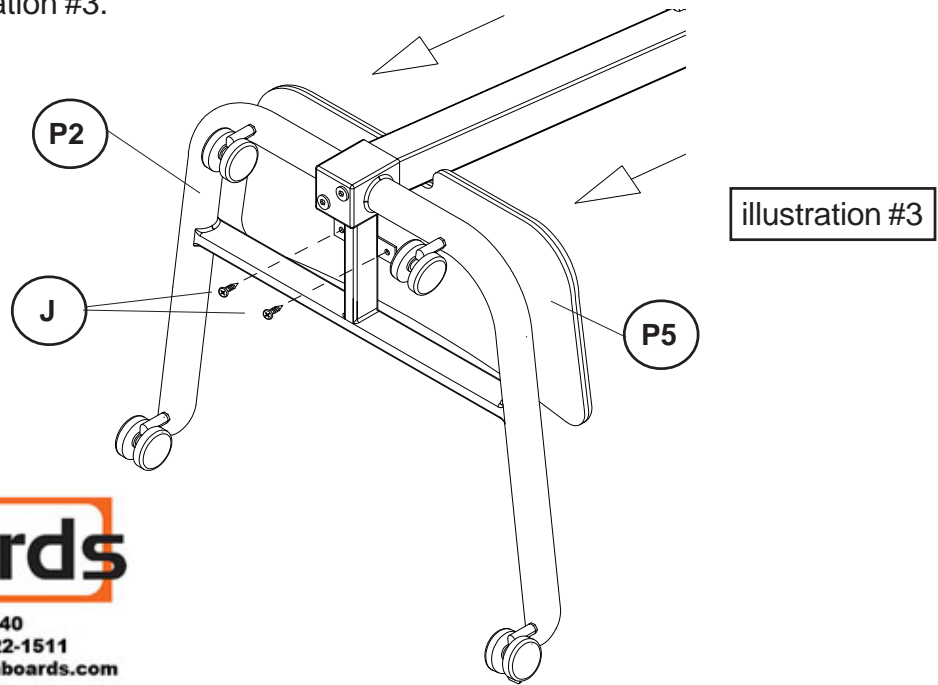

illustration #2

4.) Attach the Bottom Shelf (P5) from underneath to the top of the Base (P2) using two Phillips Screws (J) as shown in illustration #3.



**Touchboards**  
205 Westwood Ave, Long Branch, NJ 07740  
Phone: 866-94 BOARDS (26273) / (732)-222-1511  
Fax: (732)-222-7088 | E-mail: sales@touchboards.com

5.) Attach the Top Panel (P1) to the top support plate on the Pneumatic Post (P3) from underneath using four Screws (A) as shown in illustration #4.

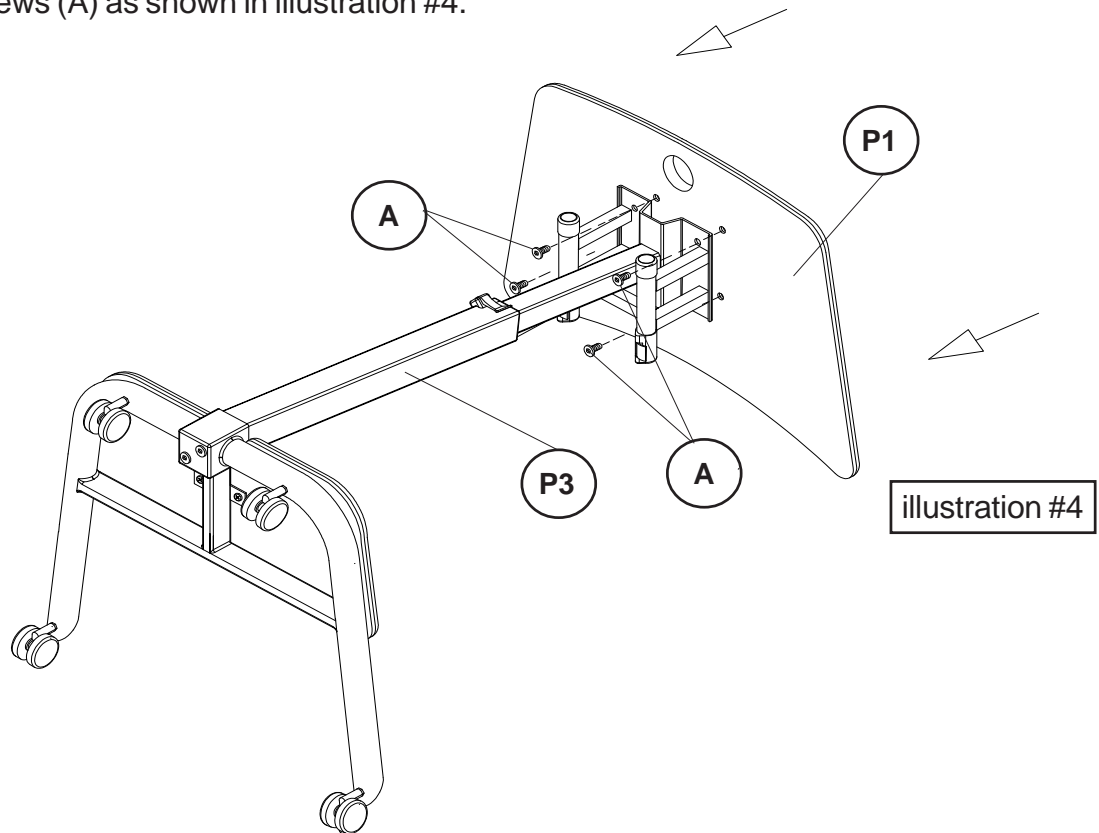

6.) Place a Spacer (H) between the Keyboard Support (P6) and the Keyboard Shelf (P4) and align holes. Secure in place using four Screws (B) as shown in illustration #5.

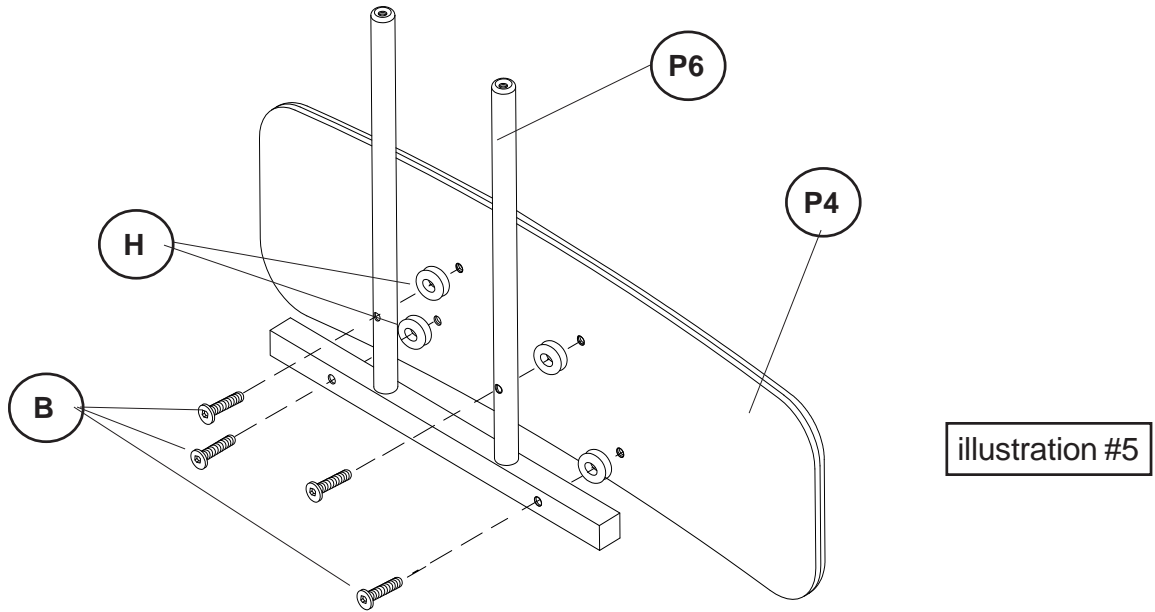

illustration #5

7.) Open the two clamp levers on the Pneumatic Post's (P3) keyboard receiver tubes under the top. Insert the tubes of the Keyboard Support (P6), position and clamp levers to hold in place. Press in the Grommet (I) into the cut-out in the Top Panel (P1) as shown in illustration #6.

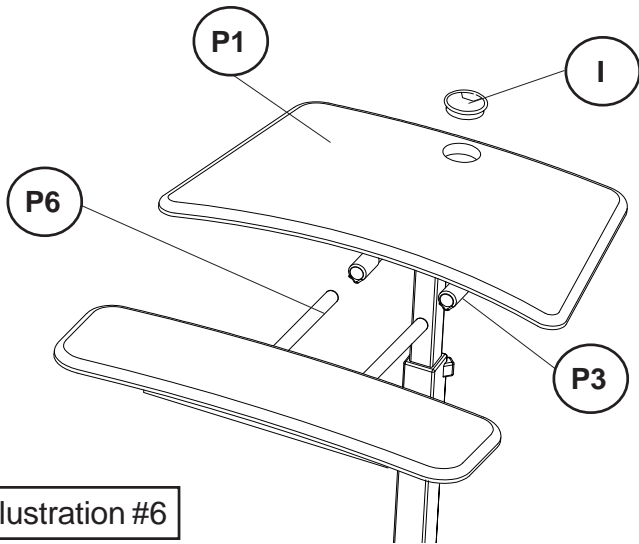

illustration #6

8.) Place a Large Washer (L) on Screw (K) and screw it in the back end of the each Keyboard Support tube as shown in illustration #7.

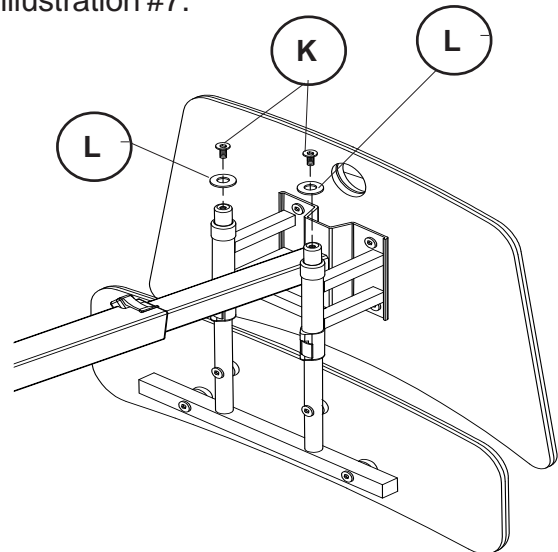
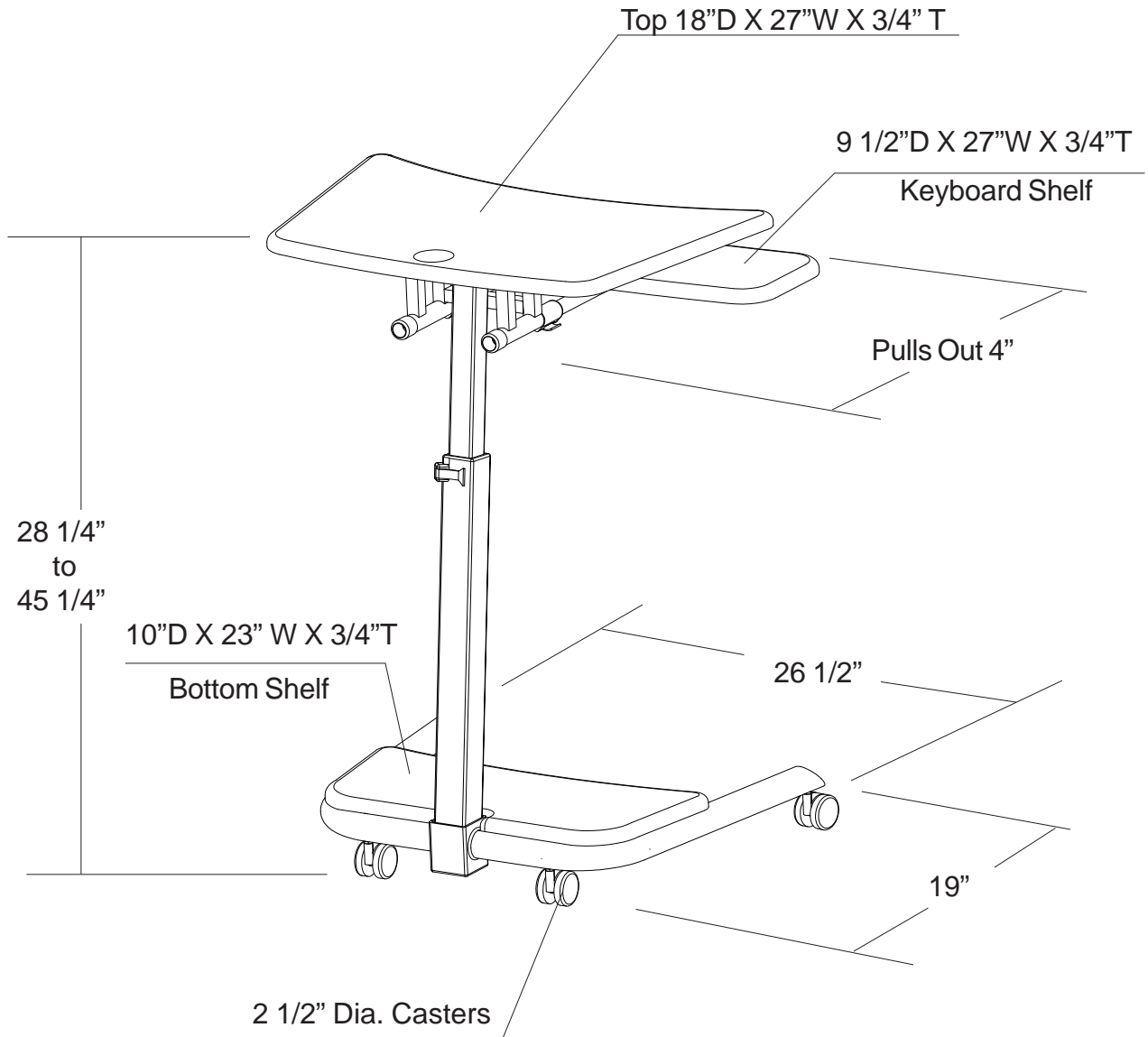

illustration #7

# Get Up Stand Up™ 90459

## Up-Rite 500 Height Adjustable Standing Desk



205 Westwood Ave, Long Branch, NJ 07740  
Phone: 866-94 BOARDS (26273) / (732)-222-1511  
Fax: (732)-222-7088 | E-mail: sales@touchboards.com

90459\_02-05-14