

Storage Wheasel Markerboard

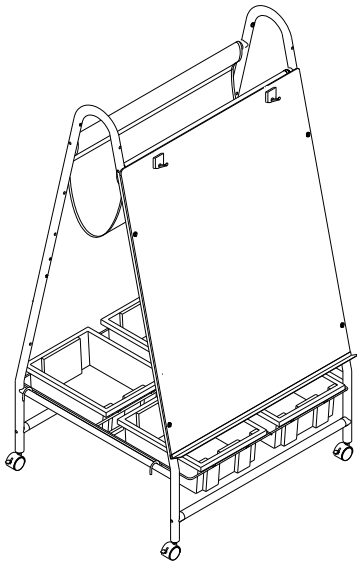

Parts List

P1		Board	1 EA
P2		Leg	2 EA
P3		Nylon Shelf	1 EA
P4		Crossbrace	4 EA
P5		Wire Rack	1 EA
P6		Storage Tub	4 EA

Hardware List

A		Screw M6 X 46mm	8 EA
A1		Screw M6 X 20mm	4 EA
B		Flat Washer 22mm	4 EA
C		Interior Threaded Post M6 X 18mm	4 EA
E		2" Locking Caster	4 EA
F		Allen Wrench	2 EA
G		Caster Wrench	1 EA
H		Chart Hooks	2 EA

1 Insert 2 Crossbraces (P4) Through Nylon Shelf (P3) as shown

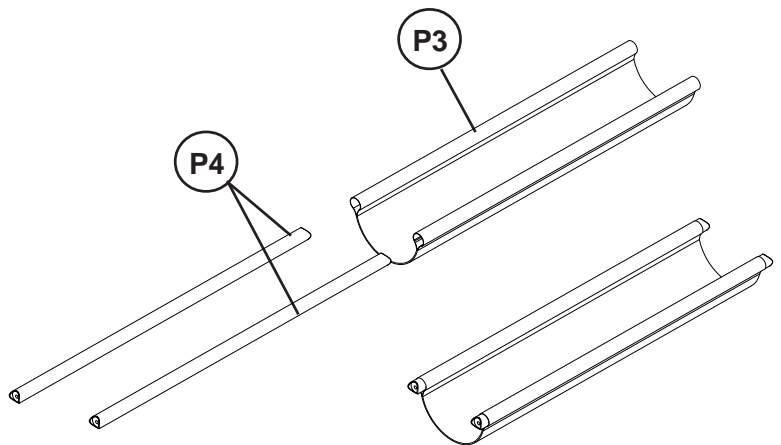

2 Attach 4 Crossbraces (P4) to the Leg Assemblies (P2) using eight Screws (A).

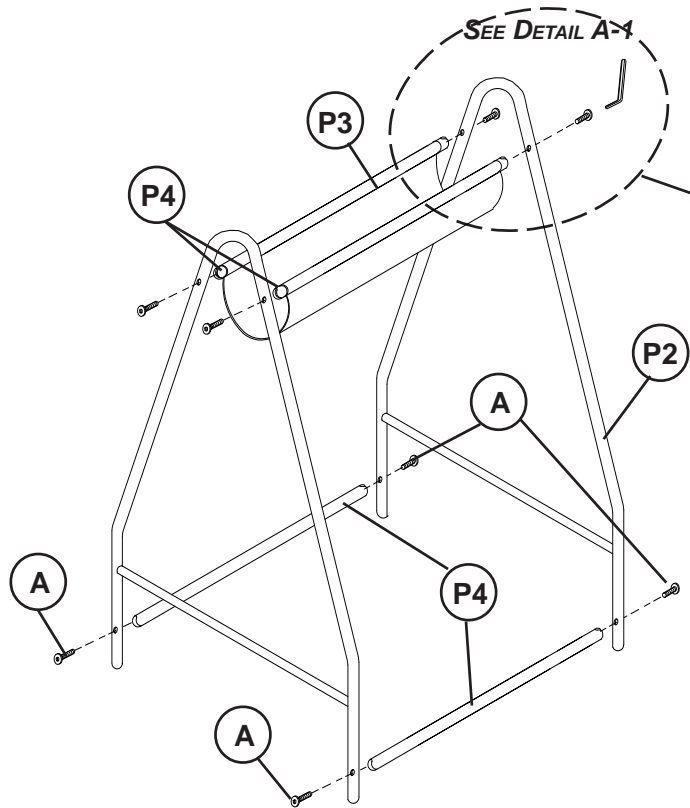

3 Use Allen Wrench (F) to tighten Screws.

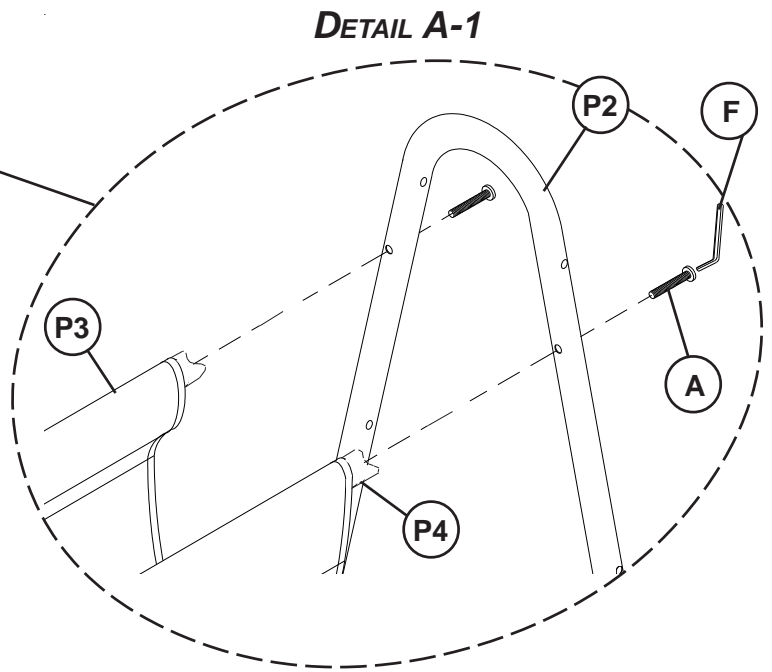

4 Install 4 Locking Casters (E).
Use Caster Wrench (G) to tighten casters.

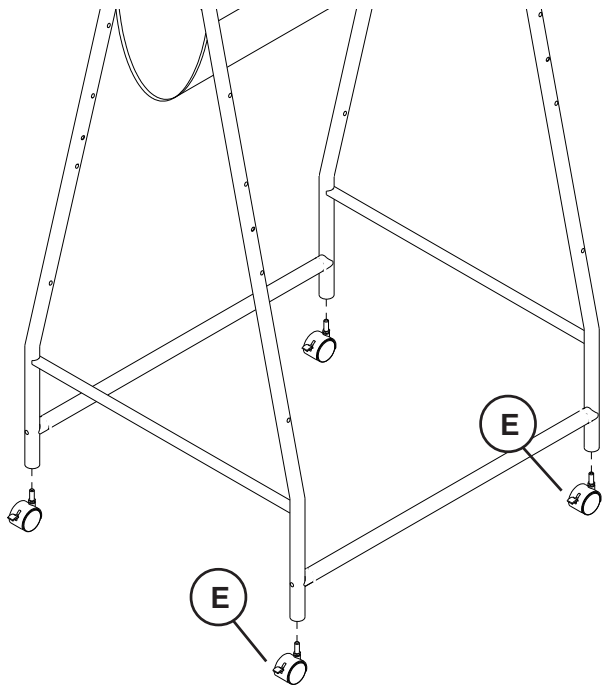

5 Attach Markerboard (P1).

Tighten screws using Allen Wrench (F).

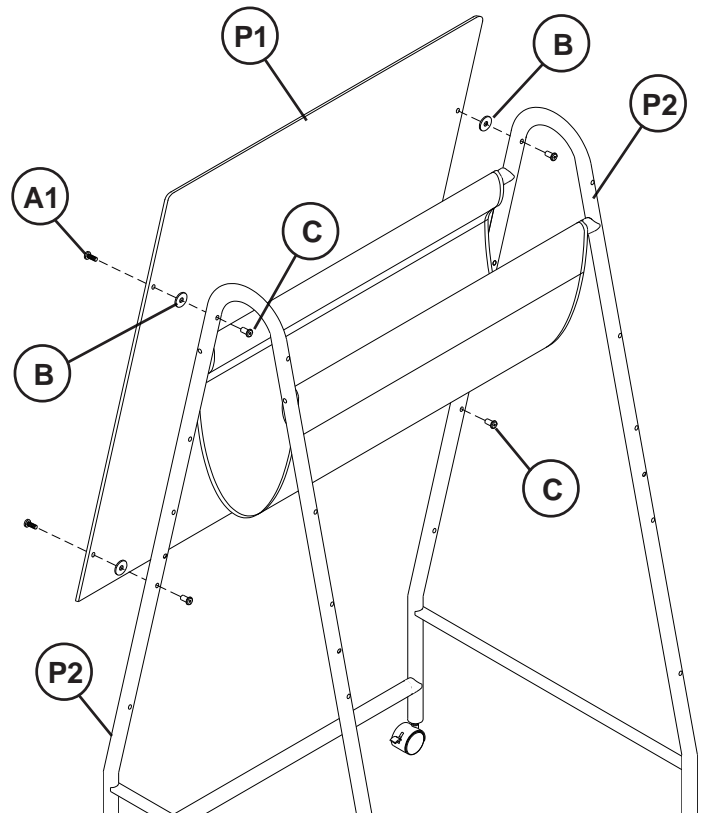

6 Attach Wire Rack (P5).

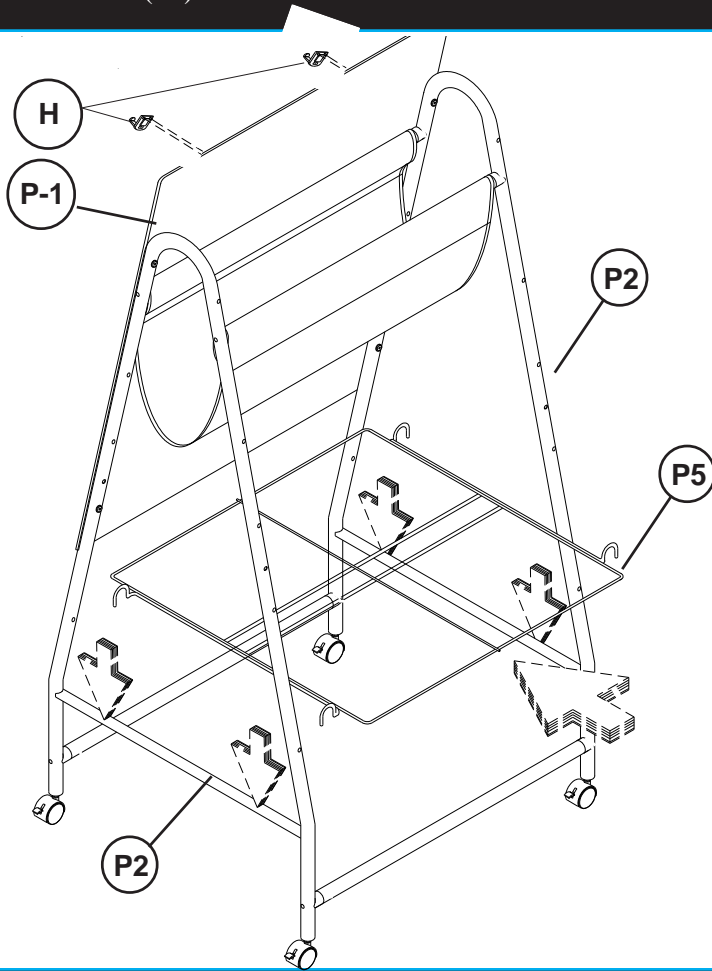

6A. Peel the paper off from the back of adhesive pad on Plastic Chart Support (H). Insert the 2 pins on the backside of the Chart Support (H) in the holes in the markerboard (P-1), as shown in Illustration # 6 and # 6-A. Firmly press the Plastic Chart Support (H) to the Writing Surface.

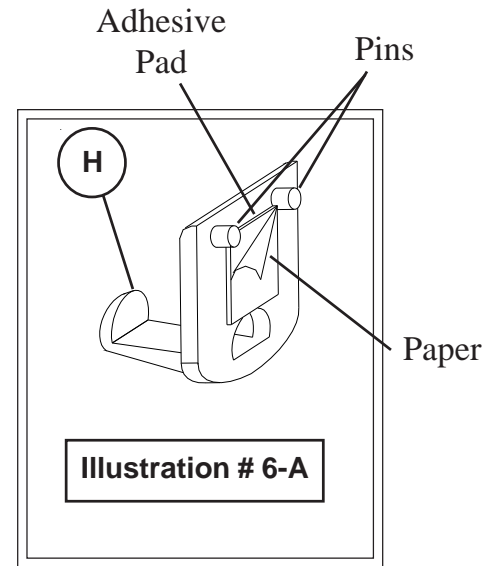

7 Insert 4 StorageTubs (P6).

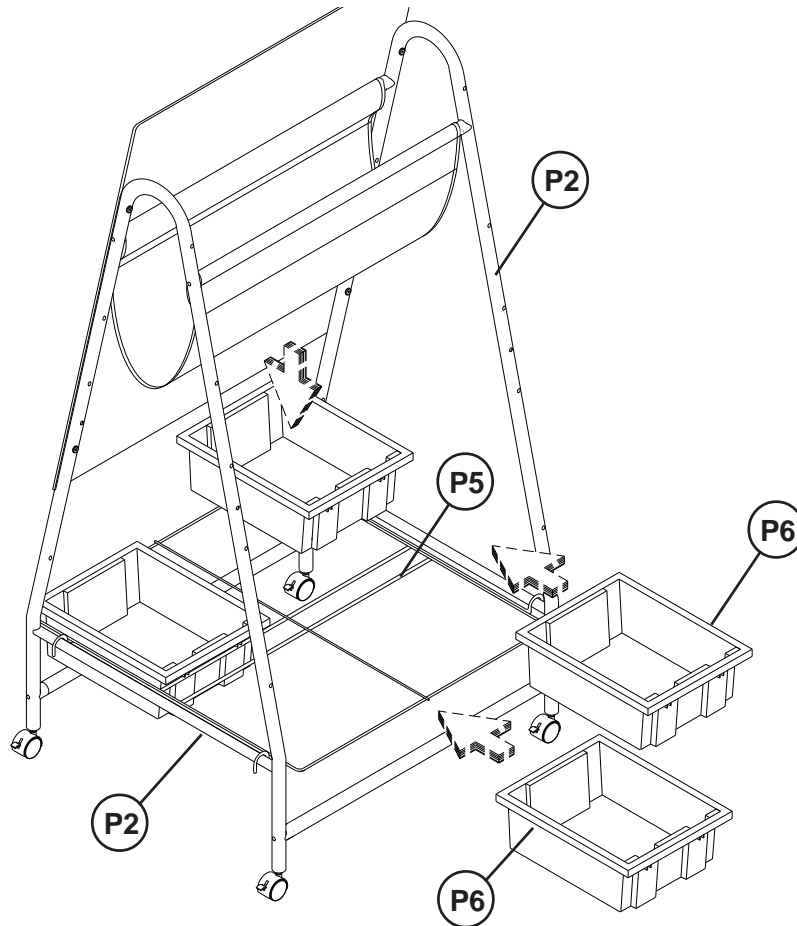

Storage Wheasel

Mobile Easel with Storage Tubs

*Storage Wheasel
w/markerboard in
upper position.*

*Storage Wheasel
w/markerboard in
lower position.*

Writing Surface
29 X 41

