



PX9230  
Digital Projector  
User Manual

# Table of contents

<b>Important safety instructions</b> .....	<b>3</b>
--	----------

<b>Introduction</b> .....	<b>7</b>
---------------------------	----------

Projector features .....	7
Shipping contents .....	8
Projector exterior view.....	9
Controls and functions .....	10

<b>Positioning your projector</b> .....	<b>14</b>
---	-----------

Choosing a location.....	14
Installing or removing the optional lens .....	15
Adjusting projected image position using lens shift.....	16
Obtaining a preferred projected image size.....	18

<b>Connection</b> .....	<b>20</b>
-------------------------	-----------

Connecting video source devices.....	21
Playing sound through the projector .....	22

<b>Operation</b> .....	<b>23</b>
------------------------	-----------

Starting up the projector .....	23
Adjusting the projected image .....	24
Using the menus.....	26
Securing the projector .....	27
Utilizing the password function .....	27
Switching input signal .....	30
Magnifying and searching for details ...	31
Selecting the aspect ratio .....	31
Optimizing the image .....	33
Setting the presentation timer .....	37
Remote paging operations .....	38

Freezing the image.....	38
Hiding the image .....	38
Locking control keys.....	39
Operating in a high altitude environment.....	39
Adjusting the sound .....	40
Using the test pattern.....	41
Using the quick install.....	41
3D Sync connection.....	41
Shutting down the projector .....	41
Menu operation .....	42

<b>Maintenance</b> .....	<b>55</b>
--------------------------	-----------

Care of the projector .....	55
Lamp information .....	56
Cleaning the filter .....	60
Replacing the filter.....	60

<b>Troubleshooting</b> .....	<b>64</b>
------------------------------	-----------

<b>Specifications</b> .....	<b>65</b>
-----------------------------	-----------

Projector specifications.....	65
Dimensions .....	66
Timing chart.....	67
RS232 command control .....	73

<b>Warranty and Copyright information</b> .....	<b>76</b>
---	-----------

# Important safety instructions

Your projector is designed and tested to meet the latest standards for safety of information technology equipment. However, to ensure safe use of this product, it is important that you follow the instructions mentioned in this manual and marked on the product.

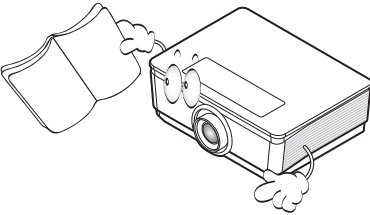
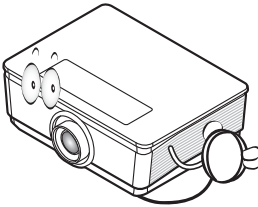
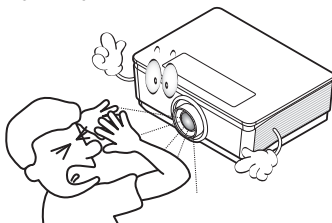
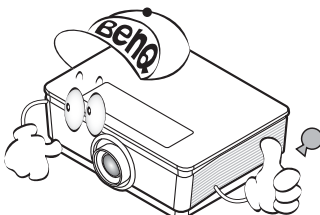
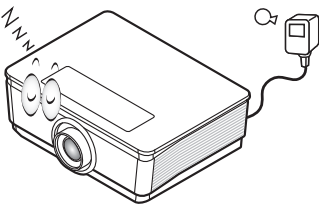
Safety Instructions	
<p>1. <b>Please read this manual before you operate your projector.</b> Save it for future reference.</p> 	<p>4. <b>Always open the lens shutter or remove the lens cap when the projector lamp is on.</b></p> 
<p>2. <b>Do not look straight at the projector lens during operation.</b> The intense light beam may damage your eyes.</p> 	<p>5. In some countries, the line voltage is NOT stable. This projector is designed to operate safely within a mains voltage between 100 to 240 volts AC, but could fail if power cuts or surges of <math>\pm 10</math> volts occur. <b>In areas where the mains voltage may fluctuate or cut out, it is recommended that you connect your projector through a power stabilizer, surge protector or uninterruptible power supply (UPS).</b></p>
<p>3. <b>Refer servicing to qualified service personnel.</b></p> 	

## Safety Instructions

6. Do not block the projection lens with any objects when the projector is under operation as this could cause the objects to become heated and deformed or even cause a fire. To temporarily turn off the lamp, press **BLANK** on the projector or remote control.

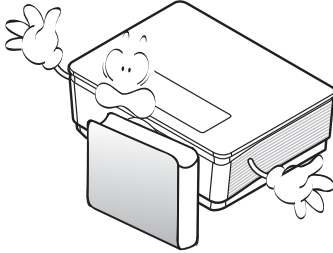

7. The lamp becomes extremely hot during operation. Allow the projector to cool for approximately 45 minutes prior to removing the lamp assembly for replacement.

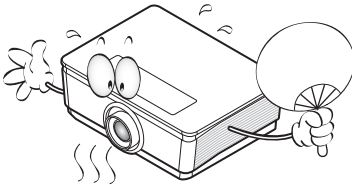

8. Do not operate lamps beyond the rated lamp life. Excessive operation of lamps beyond the rated life could cause them to break on rare occasions.

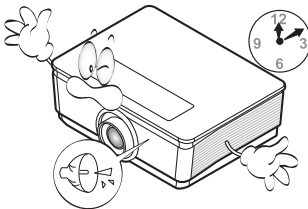

9. Never replace the lamp assembly or any electronic components unless the projector is unplugged.

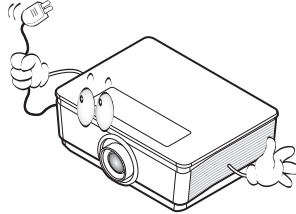

10. Do not place this product on an unstable cart, stand, or table. The product may fall, sustaining serious damage.

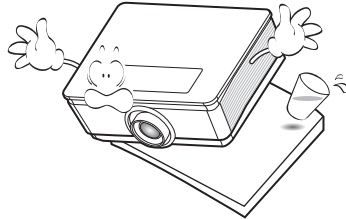

11. Do not attempt to disassemble this projector. There are dangerous high voltages inside which may cause death if you should come into contact with live parts. The only user serviceable part is the lamp which has its own removable cover.

Under no circumstances should you ever undo or remove any other covers. Refer servicing only to suitably qualified professional service personnel.

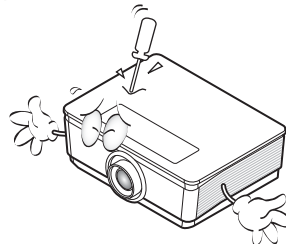



## Safety Instructions (Continued)

12. When the projector is under operation, you may sense some heated air and odor from its ventilation grill. It is a normal phenomenon and not a product defect.
13. Do not place this projector in any of the following environments.
- Space that is poorly ventilated or confined. Allow at least 50 cm clearance from walls and free flow of air around the projector.
  - Locations where temperatures may become excessively high, such as the inside of a car with all windows rolled up.
  - Locations where excessive humidity, dust, or cigarette smoke may contaminate optical components, shortening the projector's life span and darkening the image.

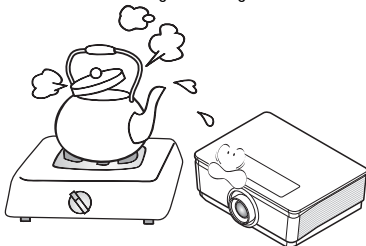

- Locations near fire alarms
- Locations with an ambient temperature above 40°C / 104°F
- Locations where the altitudes are higher than 3000 m (10000 feet).

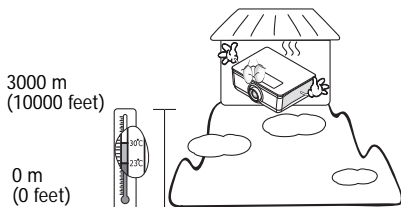

14. Do not block the ventilation holes.
- Do not place this projector on a blanket, bedding or any other soft surface.
  - Do not cover this projector with a cloth or any other item.
  - Do not place inflammables near the projector.

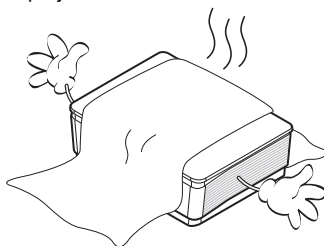

If the ventilation holes are seriously obstructed, overheating inside the projector may result in a fire.

15. Always place the projector on a level, horizontal surface during operation.
- Do not use if tilted at an angle of more than 10 degrees left to right, nor at angle of more than 15 degrees front to back. Using the projector when it is not fully horizontal may cause a malfunction of, or damage to, the lamp.

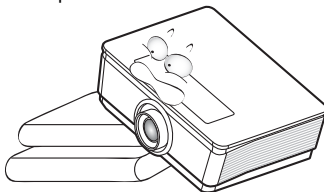

## Safety Instructions (Continued)

16. Do not stand the projector on end vertically. Doing so may cause the projector to fall over, causing injury or resulting in damage to the projector.

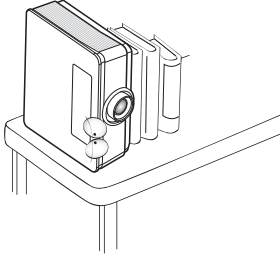

17. Do not step on the projector or place any objects upon it. Besides probable physical damage to the projector, doing so may result in accidents and possible injury.

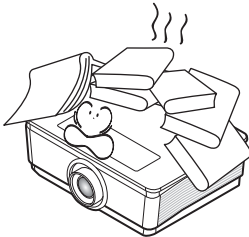

18. Do not place liquids near or on the projector. Liquids spilled into the projector may cause it to fail. If the projector does become wet, disconnect it from the power supply's wall socket and call BenQ to have the projector serviced.

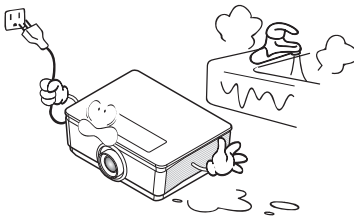

19. This product is capable of displaying inverted images for ceiling mount installation.



**Use only BenQ's Ceiling Mount Kit for mounting the projector and ensure it is securely installed.**

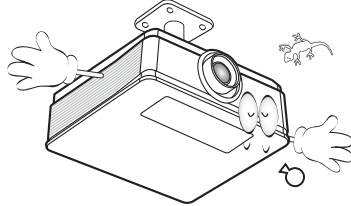

### **Ceiling mounting the projector**

**We want you to have a pleasant experience using your BenQ projector, so we need to bring this safety matter to your attention to prevent possible damage to person and property.**

If you intend to mount your projector on the ceiling, we strongly recommend that you use a proper fitting BenQ projector ceiling mount kit and that you ensure it is securely and safely installed.

If you use a non-BenQ brand projector ceiling mount kit, there is a safety risk that the projector may fall from the ceiling due to an improper attachment through the use of the wrong gauge or length screws. You can purchase a BenQ projector ceiling mount kit from the place you purchased your BenQ projector. BenQ recommends that you also purchase a separate Kensington lock compatible security cable and attach it securely to both the Kensington lock slot on the projector and the base of the ceiling mount bracket. This will perform the secondary role of restraining the projector should its attachment to the mounting bracket become loose.



**Hg - Lamp contains mercury. Manage in accordance with local disposal laws. See [www.lamprecycle.org](http://www.lamprecycle.org).**

# Introduction

## Projector features

The projector offers the following features

- **BLANK saves lamp power**

By pressing the **BLANK** button to hide the image and immediately lower lamp power at the same time.

- **USB TYPE B** jack to use the page up/down commands (like Microsoft PowerPoint) using the remote control when connected a PC.

- **USB TYPE A** jack to support 5V/1.5A output.

- **Less than 0.5W in standby condition**

Less than 0.5W power consumption under standby mode.

- **Network Control**

Integrated RJ45 connector for wired network control allowing management of projector status from a computer using a web browser.

- **Crestron RoomView<sup>®</sup>, PJ Link and AMX supported**

The projector supports Crestron eControl and RoomView, PJ Link and AMX allowing you to control and manage equipment from a remote computer via LAN connection.

- **One-key auto-adjustment**

Pressing **AUTO** on the keypad or remote control to show the best picture quality immediately.

- **Quick Cooling, Auto Power Off, Signal Power On, Direct Power On, Quick Cooling** function speeds up the cooling process when turning off the projector. **Auto Power Off** function allows the projector to turn off automatically if no input signal is detected after a set period of time. **Signal Power On** function turns on your projector automatically once detecting **COMPUTER-1** or **COMPUTER-2** the signal input and **Direct Power On** boots up the projector automatically when the power is connected.

- **3D Function supported**

Various 3D formats make the 3D function more flexible. By presenting the depth of the images, you can wear BenQ 3D glasses to enjoy the 3D movies, videos and sporting events in a more realistic way.



- **The apparent brightness of the projected image will vary depending on the ambient lighting conditions, selected input signal contrast/brightness settings, and is directly proportional to projection distance.**

- **The lamp brightness will decline over time and may vary within the lamp manufacturers specifications. This is normal and expected behavior.**

# Shipping contents

Carefully unpack and verify that you have all of the items shown below. If any of these items are missing, please contact your place of purchase.

## Standard accessories

 The supplied accessories will be suitable for your region, and may differ from those illustrated.

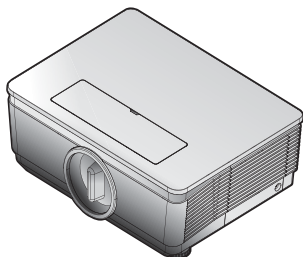

Projector

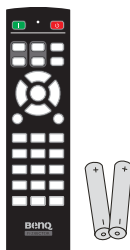

Remote control with battery

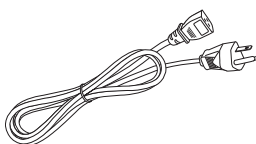

Power cord

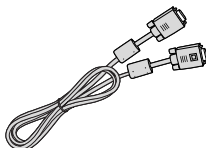

VGA cable



Installation guide

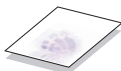

Regulatory statement



Warranty card\*

## Optional accessories

1. Spare lamp kit
2. Ceiling mount kit
3. 3D glasses

\*The warranty card is only supplied in some specific regions. Please consult your dealer for detailed information.

# Projector exterior view

## Front/upper

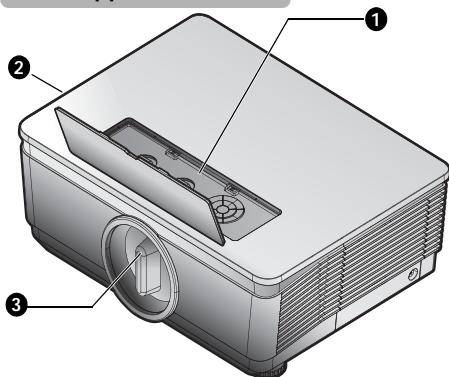

## Rear side

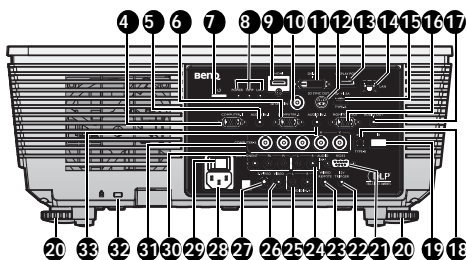

## Bottom side

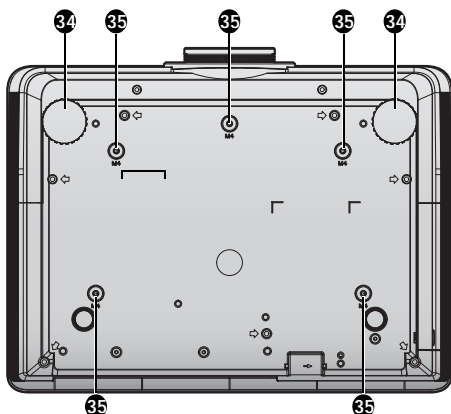

1. External control panel  
(See "Projector" on page 10 for details.)
2. Vent (cool air intake)
3. Anti-dust cap
4. COMPUTER-1 input jack
5. AUDIO IN-1 jack
6. COMPUTER-2 input jack
7. Power button
8. Indicator light (POWER, TEMPerature, LAMP)
9. HDMI input jack
10. 3D SYNC IN jack
11. DVI input
12. 3D SYNC OUT jack
13. DISPLAY PORT
14. RJ45 LAN input jack
15. USB TYPE-A port
16. MONITOT-OUT output jack
17. AUDIO OUT jack
18. USB TYPE-B port
19. Rear IR remote sensor
20. Front adjuster feet
21. RS232 control port
22. 12V TRIGGER
23. WIRED REMOTE
24. AUDIO IN-3 input jack
25. AUDIO IN-4 input jack
26. VIDEO input jack
27. S-VIDEO input jack
28. AC power cord inlet
29. AC Power Switch
30. COMPONENT Y/Pb/Pr input
31. COMPUTER-3, RGBHV(H+V), Y/ Pb(CB)/Pr(Cr) input
32. Kensington anti-theft lock slot
33. AUDIO IN-2 jack
34. Front adjuster feet
35. Ceiling mount holes

# Controls and functions

## Projector

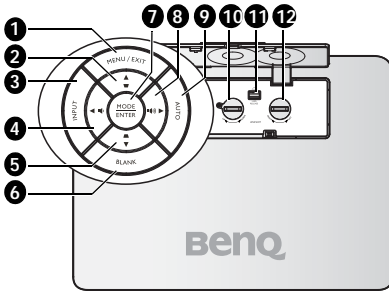

1. **MENU/EXIT**  
Turns on the On-Screen Display (OSD) menu. Goes back to previous OSD menu, exits and saves menu settings. See ["Using the menus" on page 26](#) for details.
2. **Keystone/Arrow keys (▲/▲ Up)**  
Manually corrects distorted images resulting from an angled projection. See ["Correcting Keystone" on page 25](#) for details.
3. **INPUT**  
Displays the source selection bar. See ["Switching input signal" on page 30](#) for details.
4. **◀ Left/ 🔊 Decrease volume level**  
Decreases volume. See ["Adjusting the sound level" on page 40](#) for details.
5. **Keystone/Arrow keys (▲/▼ Down)**  
Manually corrects distorted images resulting from an angled projection. See ["Correcting Keystone" on page 25](#) for details.
6. **BLANK**  
Used to hide the screen picture. See ["Hiding the image" on page 38](#) for details.
7. **MODE/ENTER**  
Selects an available picture setup mode. See ["Selecting a picture mode" on page 33](#) for details.  
Enacts the selected On-Screen Display (OSD) menu item. See ["Using the menus" on page 26](#) for details.
8. **▶ Right/ 🔊 Increase volume level**  
Increases volume. See ["Adjusting the sound level" on page 40](#) for details.  
When the On-Screen Display (OSD) menu is activated, the #2, #4, #5, and #8 keys are used as directional arrows to select the desired menu items and to make adjustments. See ["Using the menus" on page 26](#) for details.
9. **AUTO**  
Automatically determines the best picture timings for the displayed image. See ["Auto-adjusting the image" on page 24](#) for details.
10. **LENS SHIFT UP/DOWN**  
Rotate to move lens up or down.
11. **LENS RELEASE button**  
Flip to release lens.
12. **LENS SHIFT RIGHT/LEFT**  
Rotate to move lens right or left.

# Remote Control

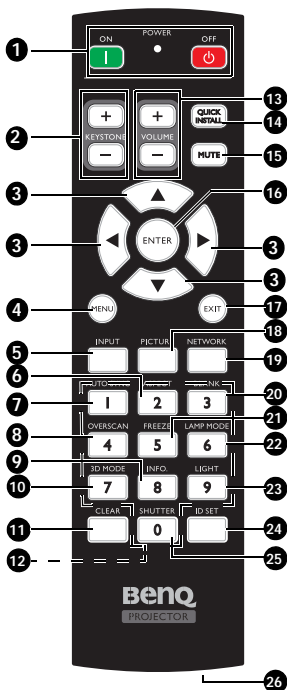

1. **ON / OFF**  
Toggles the projector between standby mode and on.
2. **KEYSTONE+ / KEYSTONE-**  
Manually corrects distorted images resulting from an angled projection.
3. **Arrow keys (▲ Up, ▼ Down, ◀ Left, ▶ Right)**  
When the On-Screen Display (OSD) menu is activated, the #3 keys are used as directional arrows to select the desired menu items and to make adjustments. See ["Using the menus" on page 26](#) for details.
4. **MENU**  
Turns on the On-Screen Display (OSD) menu. Goes back to previous OSD menu, exits and saves menu settings.

5. **INPUT**  
Selects an input source for display. See ["Switching input signal" on page 30](#) for details.
6. **ASPECT**  
Selects the display aspect ratio.
7. **AUTO SYNC**  
Automatically determines the best picture timings for the displayed image.
8. **OVERSCAN**  
Press to select overscan mode.
9. **INFO.**  
Press to display **INFORMATION** menu.
10. **3D MODE**  
Press to display 3D setup menu.
11. **CLEAR**  
Clear remote ID SET assigned to all projectors.  
Press **CLEAR** and **ID SET** for five seconds. The LED blinks three times then the ID setting is cleared.
12. **Numeric buttons**  
Enters numbers in network settings.  
 **Numeric buttons 1, 2, 3, 4 cannot be pressed when asked to enter password.**
13. **VOLUME + / VOLUME -**  
Increases/decreases the projector volume.
14. **QUICK INSTALL**  
Displays the **Quick Install** OSD menu.
15. **MUTE**  
Toggles projector audio between on and off.
16. **ENTER**  
SELECTS an available picture setup mode. Activates the selected On-Screen Display (OSD) menu item.
17. **EXIT**  
Goes back to previous OSD menu, exits and saves menu settings.
18. **PCITURE**  
Press to display **Picture** menu.

**19. NETWORK**

Selects Network Display as the input signal source.

**20. BLANK**

Used to hide the screen picture.

**21. FREEZE**

Freezes the projected image.

**22. LAMP MODE**

Press to display OSD menu to select desired lamp mode.

**23. LIGHT**

Press to open backlight of remote controller.

**24. ID SET**

Press to set remote ID.

Press **ID SET** for three seconds. The POWER indicator on the remote control blinks, then press 01~99 to designate an ID.

Press **CLEAR** and **ID SET** for five seconds. The POWER indicator on the remote control blinks a single instance to signify a switch from control by projector only or control by projector to remote control.

**25. SHUTTER**

The function is not available on this projector.

**26. WIRE REMOTE jack**

Connect to projector for wire remote control.

 The remote control number must match the projector number for accurate control.



## Remote control effective range

Infra-Red (IR) remote control sensor is located on the rear of the projector. The remote control must be held at an angle within 30 degrees perpendicular to the projector's IR remote control sensor to function correctly. The distance between the remote control and the sensor should not exceed 8 meters (~ 26 feet).

Make sure that there are no obstacles between the remote control and the IR sensor on the projector that might obstruct the infra-red beam.

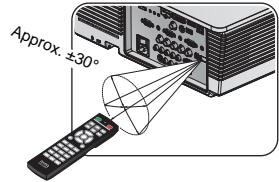
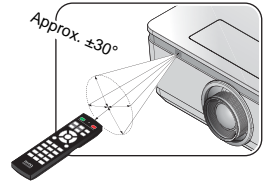

## Replacing the remote control battery

1. To open the battery cover, turn the remote control over to view its back, push on the finger grip on the cover and slide it up in the direction of the arrow as illustrated. The cover will slide off.
2. Remove any existing batteries (if necessary) and install two AA batteries observing the battery polarities as indicated in the base of the battery compartment. Positive (+) goes to positive and negative (-) goes to negative.
3. Refit the cover by aligning it with the base and sliding it back down into position. Stop when it clicks into place.

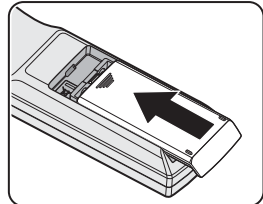
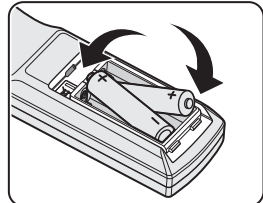
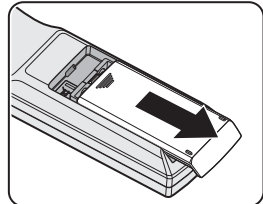

- Avoid excessive heat and humidity.
- There may be battery damage if the battery is incorrectly replaced.
- Replace only with the same or equivalent type recommended by the battery manufacturer.
- Dispose of the used battery according to the battery manufacturer's instructions.
- Never throw a battery into a fire. There may be danger of an explosion.
- If the battery is dead or if you will not be using the remote control for a long time, remove the battery to prevent damage to the remote control from possible battery leakage.
- RISK OF EXPLOSION IF BATTERY IS REPLACED BY AN INCORRECT TYPE.
- DISPOSE OF USED BATTERIES ACCORDING TO THE INSTRUCTIONS.

# Positioning your projector

## Choosing a location

Your projector is designed to be installed in one of four possible installation locations:

### 1. Front Table

Select this location with the projector placed on a table in front of the screen. This is the most common way to position the projector for quick setup and portability.

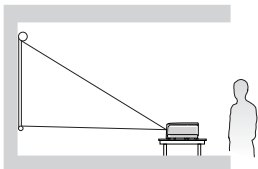

### 2. Rear Table

Select this location with the projector placed on a table behind the screen.

Note that a special rear projection screen is required.

\*Set **Rear Table** in the **SYSTEM SETUP: Basic > Projector Installation** menu after you turn the projector on.

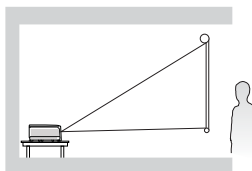

### 3. Front Ceiling

Select this location with the projector suspended upside-down from the ceiling in front of the screen.

Purchase the BenQ Projector Ceiling Mounting Kit from your dealer to mount your projector on the ceiling.

\*Set **Front Ceiling** in the **SYSTEM SETUP: Basic > Projector Installation** menu after you turn the projector on.

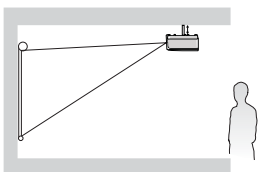

### 4. Rear Ceiling

Select this location with the projector suspended upside-down from the ceiling behind the screen.

Note that a special rear projection screen and the BenQ Projector Ceiling Mounting Kit are required for this installation location.

\*Set **Rear Ceiling** in the **SYSTEM SETUP: Basic > Projector Installation** menu after you turn the projector on.

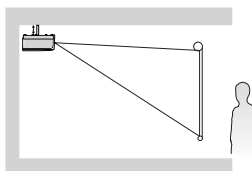

Your room layout or personal preference will dictate which installation location you select. Take into consideration the size and position of your screen, the location of a suitable power outlet, as well as the location and distance between the projector and the rest of your equipment.

# Installing or removing the optional lens

- ⚠ Do not shake or place excessive pressure on the projector or the lens components as the projector and lens components contain precision parts.
- Before removing or installing the lens, be sure to turn off the projector, wait until the cooling fans stop, and turn off the main power switch.
- Do not touch the lens surface when removing or installing the lens.
- Keep fingerprints, dust or oil off the lens surface. Do not scratch the lens surface.
- Work on a level surface with a soft cloth under it to avoid scratching.
- If you remove and store the lens, attach the lens cap to the projector to keep off dust and dirt.

## Removing the existing lens from the projector

1. Flip up the top cover
2. Push the LENSE RELEASE button to the unlock position.
3. Grasp the lens.
4. Rotate the lens counterclockwise. The existing lens will be disengaged.
5. Pull out the existing lens slowly.

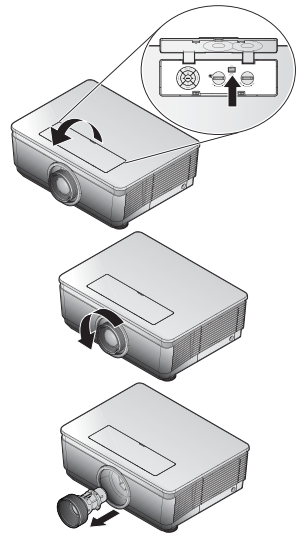

## Installing the new lens

Remove both end caps from the lens.

 Removal of the plastic body cap before inserting a lens for the first time.

1. Align the notches and correctly position.
2. Rotate the lens clockwise until you feel it click into place.

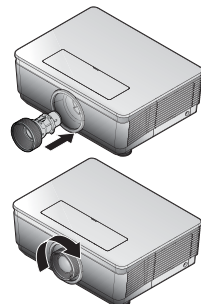

# Adjusting projected image position using lens shift

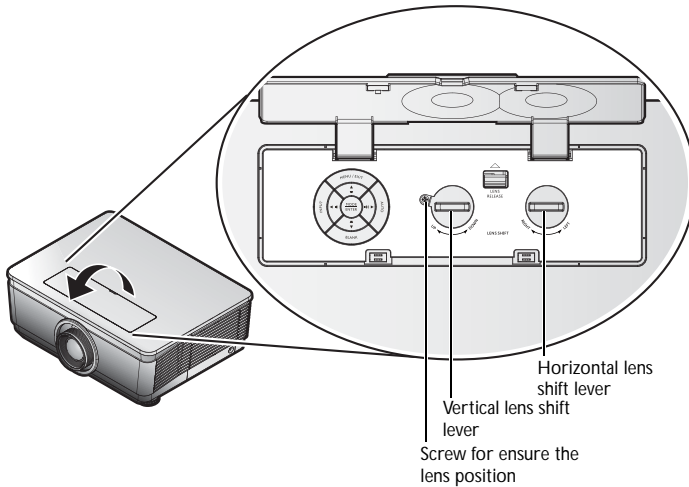

 **Suggest to loosen the screw before lens shift adjustment and tighten up after finished adjustment.**

The Lens Shift function can be used to adjust the position of the projected image either horizontally or vertically within the range detailed below.

## Adjusting the vertical image position

The vertical image height can be adjusted between 50% and -10% for XGA of offset position. Please consult the Lens Shift Range diagram below for further clarification.

## Adjusting the horizontal image position

With the lens in the center position the horizontal image position can be adjusted to the left or right by up to a maximum of 5% of the image width. Please consult the Lens Shift Range diagram below for further clarification.

# Lens shift range diagram

## XGA

### Desk-Front Projection

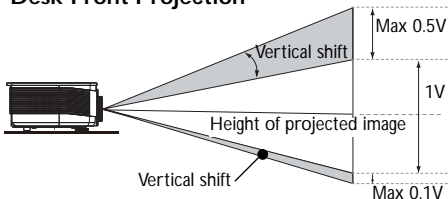

### Ceiling Mount-Front Projection

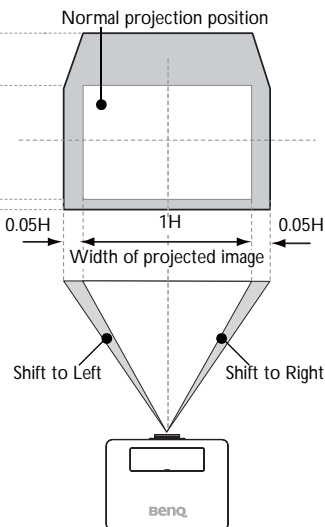
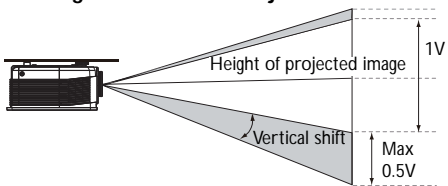

## Notice (when edge blending)

- To avoid the image shaking or some pixels in the display may be misaligned, do not use the projector in the following location:
  - In a building close to a construction site.
  - In a room where an air conditioner unit is working and it vibrates.
  - In a place where the temperature changes dramatically that may cause thermal contraction.
- Before making any adjustment, leave the projector lit for at least 45 minutes after its lamp is turned on. This allows the internal temperature of the projector to stabilize.

## Adjusting the Zoom/Focus

You may turn the zoom ring to zoom in or out. To focus the image, rotate the focus ring until the image is clear. The projector will focus at distances. See page 18.

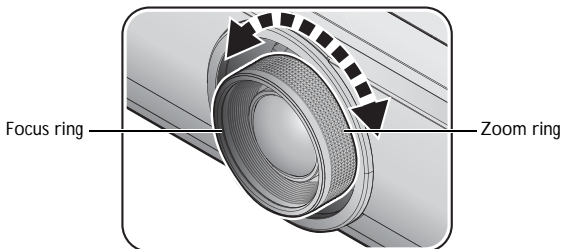

# Obtaining a preferred projected image size

The distance from the projector lens to the screen, the zoom setting (if available), and the video format each factors in the projected image size.

## Projection dimensions

Refer to "Dimensions" on page 66 for the center of lens dimensions of this projector before calculating the appropriate position.

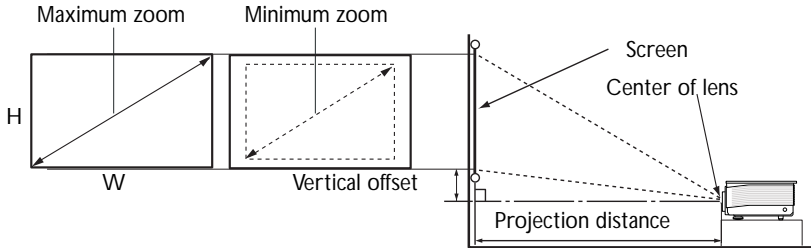

The screen aspect ratio is 4:3 and the projected picture is 4:3.

Screen Size						Wide Fix Lens		Wide Zoom Lens			
Diagonal		Width		Height		Distance					
						NA		Wide		Tele	
Inch	m	Inch	m	Inch	m	Inch	m	Inch	m	Inch	m
80	2.03	64	1.63	48	1.22	52	1.32	73	1.85	86	2.19
100	2.54	80	2.03	60	1.52	65	1.65	91	2.32	108	2.74
120	3.05	96	2.44	72	1.83	78	1.98	109	2.78	129	3.28
150	3.81	120	3.05	90	2.29	97	2.47	137	3.47	162	4.11
200	5.08	160	4.06	120	3.05	130	3.29	182	4.63	216	5.47
300	7.62	240	6.10	180	4.57	194	4.94	274	6.95	323	8.21
400	10.16	320	8.13	240	6.10	259	6.58	365	9.27	431	10.95

Screen Size						Standard				Semi Long Zoom			
Diagonal		Width		Height		Distance							
						Wide		Tele		Wide		Tele	
Inch	m	Inch	m	Inch	m	Inch	m	Inch	m	Inch	m	Inch	m
80	2.03	64	1.63	48	1.22	102	2.60	128	3.25	128	3.25	192	4.88
100	2.54	80	2.03	60	1.52	128	3.25	160	4.06	160	4.06	240	6.10
120	3.05	96	2.44	72	1.83	154	3.90	192	4.88	192	4.88	288	7.32
150	3.81	120	3.05	90	2.29	192	4.88	240	6.10	240	6.10	360	9.14
200	5.08	160	4.06	120	3.05	256	6.50	320	8.13	320	8.13	480	12.19
300	7.62	240	6.10	180	4.57	384	9.75	480	12.19	480	12.19	720	18.29
400	10.16	320	8.13	240	6.10	512	13.00	640	16.26	640	16.26	960	24.38

Screen Size						Long Zoom			
Diagonal		Width		Height		Distance			
						Wide		Tele	
Inch	m	Inch	m	Inch	m	Inch	m	Inch	m
80	2.03	64	1.63	48	1.22	199	5.06	332	8.42
100	2.54	80	2.03	60	1.52	249	6.32	414	10.53
120	3.05	96	2.44	72	1.83	299	7.58	497	12.63
150	3.81	120	3.05	90	2.29	373	9.48	622	15.79
200	5.08	160	4.06	120	3.05	498	12.64	829	21.05
300	7.62	240	6.10	180	4.57	746	18.96	1243	31.58
400	10.16	320	8.13	240	6.10	995	25.28	1658	42.10

\*Gray areas mean it more than the lens ensuring distance, only for reference.

 There is 5% tolerance among these numbers due to optical component variations. BenQ recommends that if you intend to permanently install the projector, you should physically test the projection size and distance using the actual projector before you permanently install it, so as to make allowance for this projector's optical characteristics. This will help you determine the exact mounting position so that it best suits your installation location.

# Connection

When connecting a signal source to the projector, be sure to:

1. Turn all equipment off before making any connections.
2. Use the correct signal cables for each source.
3. Ensure the cables are firmly inserted.

In the connections shown below, some cables may not be included with the projector (see "Shipping contents" on page 8). They are commercially available from electronics stores.

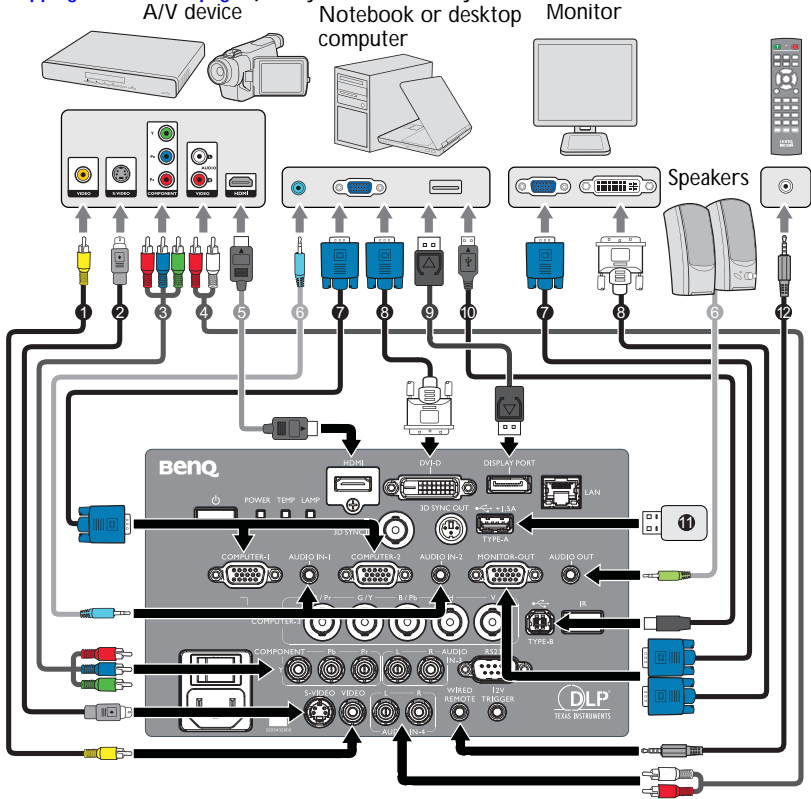

- |   |  |
|---|--|
| <ol style="list-style-type: none"> <li>1. Video cable</li> <li>2. S-Video cable</li> <li>3. Component video cable</li> <li>4. Audio L/R cable</li> <li>5. HDMI cable</li> <li>6. Audio cable</li> </ol> | <ol style="list-style-type: none"> <li>7. VGA cable</li> <li>8. VGA to DVI-A cable</li> <li>9. DISPLAYPORT cable</li> <li>10. USB cable</li> <li>11. Type-A port power 1.5A</li> <li>12. Wired remote control cable</li> </ol> |
|---|--|







Many notebooks do not turn on their external video ports when connected to a projector. Usually a key combo like FN + F3 or CRT/LCD key turns the external display on/off. Locate a function key labeled CRT/LCD or a function key with a monitor symbol on the notebook. Press FN and the labeled function key simultaneously. Refer to your notebook's documentation to find your notebook's key combination.

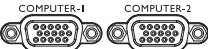

# Connecting video source devices

You need only connect the projector to a video source device using just one of the connecting methods, however each provides a different level of video quality. The method you choose will most likely depend upon the availability of matching terminals on both the projector and the video source device as described below:

Terminal name	Terminal appearance	Picture quality
HDMI	 The icon shows a rectangular HDMI port with a small circle containing a plus sign below it.	Best
Component Video	 Two side-by-side icons labeled 'COMPUTER-1' and 'COMPUTER-2', each showing a 15-pin D-sub connector.	Better
S-Video	 A circular icon labeled 'S-VIDEO' with a central pin and a surrounding ring of pins.	Good
Video	 A circular icon labeled 'VIDEO' with a central pin and a surrounding ring of pins, similar to S-Video but with a different internal structure.	Normal

 If the selected video image is not displayed after the projector is turned on and the correct video source has been selected, check that the video source device is turned on and operating correctly. Also check that the signal cables have been connected correctly.

## Playing sound through the projector

You can connect separate amplified speakers to the AUDIO OUT socket of the projector.

If you have a separate sound system, you will most likely want to connect the audio output of your Video source device to that sound system, instead of to the mono audio projector.

Once connected, the audio can be controlled by the projector On-Screen Display (OSD) menus.

The table below describes the connection methods for different devices, and where the sound is from.

Device	Audio input port	The projector can play the sound from...	Audio output port
COMPUTER-1	AUDIO-1	AUDIO-1	AUDIO OUT
COMPUTER-2/ COMPUTER-3/ DVI-D	AUDIO IN-2 (mini jack)	AUDIO IN-2 (mini jack)	AUDIO OUT
COMPONENT	AUDIO-3 (L/R)	AUDIO-3 (L/R)	AUDIO OUT
S-VIDEO/VIDEO	AUDIO-4	AUDIO-4	AUDIO OUT
HDMI	HDMI	HDMI	AUDIO OUT
DISPLAY PORT	DISPLAY PORT	DISPLAY PORT	AUDIO OUT
The selected input signal determines which sound will be played by the projector speaker, and which sound will be output from the projector when AUDIO OUT is connected. If you select the COMPUTER-2/COMPUTER-3/DVI-D signal, the projector can play the sound received from AUDIO IN-2 mini jack. If you select the COMPONENT signal, the projector can play the sound received from AUDIO IN-3 (L/R).			

# Operation

## Starting up the projector

1. Plug the power cord into the projector and into a wall socket. Turn on the wall socket switch (where fitted). Check that the **POWER indicator light** on the projector lights orange after power has been applied.



Please use the original accessories (e.g. power cable) only with the device to avoid possible dangers such as electric shock and fire.

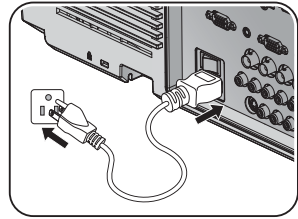

2. Press **POWER** on the projector or remote control  to start the projector and a start up tone sounds. The **POWER indicator light** flashes green and stays green when the projector is on.

The start up procedure takes about 30 seconds. In the later stage of start up, a startup logo is projected.

(If necessary) Rotate the focus ring to adjust the image clearness.

To turn off the ring tone, see "[Turning off the Power on/off ring tone](#)" on page 40 for details.



If the projector is still hot from previous activity, it will run the cooling fan for approximately 90 seconds before energizing the lamp.

3. To use the OSD menus, please set them to your familiar language first.
4. If you are prompted for a password, press the arrow keys to enter a six digit password. See "[Utilizing the password function](#)" on page 27 for details.
5. Switch all of the connected equipment on.
6. The projector will start to search for input signals. The current input signal being scanned displays in the upper left corner of the screen. If the projector doesn't detect a valid signal, the message '**No Signal**' will continue displaying until an input signal is found.

Please select language			
English	한국어	Hrvatski	हिन्दी
Français	Svenska	Română	
Deutsch	Nederlands	Norsk	
Italiano	Türkçe	Dansk	
Español	Čeština	Български	
Русский	Português	suomi	
繁體中文	ไทย	Indonesian	
簡體中文	Polski	Ελληνικό	
日本語	Magyar	ქართული	

Press Enter to confirm, Exit to leave

You can also press **SOURCE** on the projector or remote control to select your desired input signal. See "[Switching input signal](#)" on page 30 for details.



If the frequency/resolution of the input signal exceeds the projector's operating range, you will see the message 'Out of Range' displayed on a blank screen. Please change to an input signal which is compatible with the projector's resolution or set the input signal to a lower setting. See "[Timing chart](#)" on page 67 for details.



To maintain the lamp life, once you turn the projector on, wait at least 5 minutes before turning it off.

# Adjusting the projected image

## Adjusting the projection angle

The projector is equipped with two front adjuster feet. These adjusters change the image height and projection angle. To adjust the projector:

1. Screw the front adjuster foot. Once the image is positioned where you want it.
2. Screw the adjuster foot to fine tune the horizontal angle.

To retract the foot. Screw the adjuster foot in a reverse direction.

If the projector is not placed on a flat surface or the screen and the projector are not perpendicular to each other, the projected image becomes trapezoidal. To correct this situation, see "[Correcting Keystone](#)" on page 25 for details.

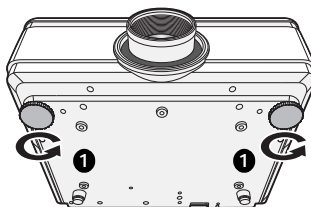

 **Do not look into the lens while the lamp is on. The strong light from the lamp may cause damage to your eyes.**

## Auto-adjusting the image

In some cases, you may need to optimize the picture quality. To do this, press **AUTO** on the projector or remote control. Within 3 seconds, the built-in Intelligent Auto Adjustment function will re-adjust the values of Frequency and Clock to provide the best picture quality.

The current source information will be displayed in the upper left corner of the screen for 3 seconds.

-  • The screen will be blank while **AUTO** is functioning.
- This function is only available when PC signal (analog RGB) is selected.

## Fine-tuning the image size and clarity

1. Adjust the projected image to the size that you need using the **ZOOM** ring.
2. Sharpen the image by rotating the **FOCUS** ring.

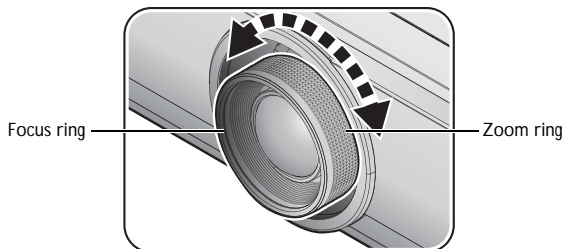

# Correcting Keystone

Keystoning refers to the situation where the projected image is noticeably wider at either the top or bottom. It occurs when the projector is not perpendicular to the screen.

- Using the remote control

Press **▼/▲** on the projector or **KEYSTONE** on the remote control to display the Keystone correction page. Press **▲** to correct keystone at the top of the image. Press **▼** to correct keystone at the bottom of the image.



Press **▼/▲**.

Press **▲/▼**.

- Using the OSD menu

1. Press **MENU** and then press **◀/▶** until the **Display** menu is highlighted.
2. Press **▼** to highlight **Keystone** and press **ENTER**. The **Keystone** correction page displays.
3. Press **▼** to correct keystone at the top of the image or press **▲** to correct keystone at the bottom of the image.

# Using the menus

The projector is equipped with On-Screen Display (OSD) menus for making various adjustments and settings.

Below is the overview of the OSD menu.



To use the OSD menus, please set them to your familiar language first.

1. Press **ENTER** on the projector or remote control to turn the OSD menu on.
3. Press **▼** to highlight **Language** and press **◀/▶** to select a preferred language.



2. Use **◀/▶** to highlight the **System Setup: Basic** menu.
4. Press **ENTER** twice\* on the projector or remote control to leave and save the settings.

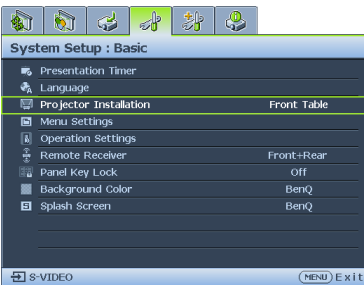

\*The first press leads you back to the main menu and the second press closes the OSD menu.

# Securing the projector

## Using a security cable lock

The projector has to be installed in a safe place to prevent theft. Otherwise, purchase a lock, such as a Kensington lock, to secure the projector. You can locate a Kensington lock slot on the left side of the projector. See "[Kensington anti-theft lock slot](#)" on [page 9](#) for details.

A Kensington security cable lock is usually a combination of key(s) and a lock. Refer to the lock's documentation for finding out how to use it.

## Utilizing the password function

For security purposes and to help prevent unauthorized use, the projector includes an option for setting up password security. The password can be set through the On-Screen Display (OSD) menu.

 **WARNING:** You will be inconvenienced if you activate the power-on lock functionality and subsequently forget the password. Print out this manual (if necessary) and write the password you used in this manual, and keep the manual in a safe place for later recall.

## Setting a password

 Once a password has been set, the projector cannot be used unless the correct password is entered every time the projector is started.

1. Open the OSD menu and go to the **System Setup: Advanced > Security Settings** menu. Press **ENTER**. The **Security Settings** page displays.
2. Highlight **Change Security Settings** and press **ENTER**.
3. As pictured to the right, the four arrow keys (**▲**, **▼**, **◀**, **▶**) respectively represent 4 digits (1, 2, 3, 4). According to the password you desire to set, press the arrow keys to enter six digits for the password.
4. Confirm the new password by re-entering the new password.  
Once the password is set, the OSD menu returns to the **Security Settings** page.
5. To activate the **Power on Lock** function, press **▲/▼** to highlight **Power on Lock** and press **◀/▶** to select **On**.

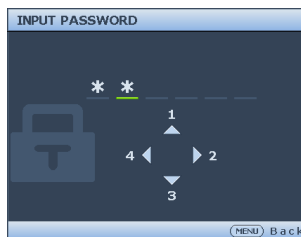

 The digits being input will display as asterisks on-screen. Write your selected password down here in this manual in advance or right after the password is entered so that it is available to you should you ever forget it.

Password: \_\_\_\_\_

Keep this manual in a safe place.

6. To leave the OSD menu, press **MENU**.

## If you forget the password

If the password function is activated, you will be asked to enter the six-digit password every time you turn on the projector. If you enter the wrong password, the password error message as pictured to the right displays lasting for three seconds, and the message **'INPUT PASSWORD'** follows. You can retry by entering another six-digit password, or if you did not record the password in this manual, and you absolutely do not remember it, you can use the password recall procedure. See ["Entering the password recall procedure" on page 28](#) for details.

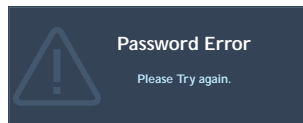

If you enter an incorrect password 5 times in succession, the projector will automatically shut down in a short time.

## Entering the password recall procedure

1. Press and hold **AUTO** on the projector or remote control for 3 seconds. The projector will display a coded number on the screen.
2. Write down the number and turn off your projector.
3. Seek help from the local BenQ service center to decode the number. You may be required to provide proof of purchase documentation to verify that you are an authorized user of the projector.

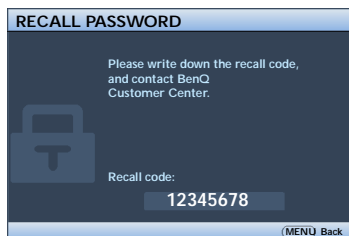



## Changing the password

1. Open the OSD menu and go to the **System Setup: Advanced > Security Settings > Change password** menu.
2. Press **ENTER**. The message '**INPUT CURRENT PASSWORD**' displays.
3. Enter the old password.
  - If the password is correct, another message '**INPUT NEW PASSWORD**' displays.
  - If the password is incorrect, the password error message displays lasting for three seconds, and the message '**INPUT CURRENT PASSWORD**' displays for your retry. You can press **MENU** to cancel the change or try another password.
4. Enter a new password.

 The digits being input will display as asterisks on-screen. Write your selected password down here in this manual in advance or right after the password is entered so that it is available to you should you ever forget it.

Password: \_\_\_\_\_

Keep this manual in a safe place.

5. Confirm the new password by re-entering the new password.
6. You have successfully assigned a new password to the projector. Remember to enter the new password next time the projector is started.
7. To leave the OSD menu, press **MENU**.

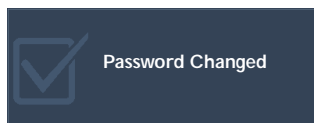

## Disabling the password function

To disable password protection, go back to the **System Setup: Advanced > Security Settings > Change Security Settings** menu after opening the OSD menu system. Press **ENTER**. The message "INPUT PASSWORD" appears. Enter the current password.

1. If the password is correct, the OSD menu returns to the **Security Settings**. Press **▼** highlight **Power On Lock** and press **◀/▶** to select **Off**. You will not have to enter the password next time you turn on the projector.
2. If the password is incorrect, the password error message displays lasting for three seconds, and the message '**INPUT PASSWORD**' displays for your retry. You can press **MENU** to cancel the change or try another password.

 Though the password function is disabled, you need to keep the old password in hand should you ever need to re-activate the password function by entering the old password.

# Switching input signal

The projector can be connected to multiple devices at the same time. However, it can only display one full screen at a time.

Be sure the **Quick Auto Search** function in the **Source** menu is **On** (which is the default of this projector) if you want the projector to automatically search for the signals.

You can also manually cycle through the available input signals.

1. Press **SOURCE** on the projector or press input source directly from the remote control. A source selection bar displays.
2. Press **▲/▼** until your desired signal is selected and press **ENTER**.  
Once detected, the selected source information will display on the screen for seconds. If there is multiple equipment connected to the projector, repeat steps 1-2 to search for another signal.

-  • The brightness level of the projected image will change accordingly when you switch between different input signals. Data (graphic) "PC" presentations using mostly static images are generally brighter than "Video" using mostly moving images (movies).
- For best display picture results, you should select and use an input signal which outputs at this resolution. Any other resolutions will be scaled by the projector depending upon the 'aspect ratio' setting, which may cause some image distortion or loss of picture clarity. See ["Selecting the aspect ratio" on page 31](#) for details.

## Changing Color Space

In the unlikely event that you connect the projector to a DVD player via the projector's **HDMI** input and the projected picture displays wrong colors, please change the color space.

To do this:

1. Press **MENU** and then press **◀/▶** until the **SOURCE** menu is highlighted.
2. Press **▼** to highlight **Color Space Conversion** and press **◀/▶** to select the setting.

-  This function is only available when the HDMI input socket is in use.

## Magnifying and searching for details

If you need to find the details on the projected picture, magnify the picture. Use the direction arrow keys for navigating the picture.

1. Press **MENU** and then press **◀/▶** until the **Display** menu is highlighted.
2. Press **▼** to highlight **Digital Zoom** and press **ENTER**. The Zoom bar displays.
3. Press **▼** on the projector repeatedly to magnify the picture to a desired size.
4. To navigate the picture, press **ENTER** to switch to the panning mode and press the directional arrows (**▲**, **▼**, **◀**, **▶**) to navigate the picture.
5. To reduce size of the picture, press **ENTER** to switch back to the zoom in/out functionality, and press **AUTO** to restore the picture to its original size. You can also press **▼** repeatedly until it is restored to the original size.

 The picture can only be navigated after the picture is magnified. You can further magnify the picture while searching for details.

## Selecting the aspect ratio

The 'aspect ratio' is the ratio of the image width to the image height. Most analog TV and computers are in 4:3 ratio, and digital TV and DVDs are usually in 16:9 ratio.

With the advent of digital signal processing, digital display devices like this projector can dynamically stretch and scale the image output to a different aspect than that of the image input signal.

To change the projected image ratio (no matter what aspect the source is):

- Using the remote control
  1. Press **Aspect** to show the current setting.
  2. Press **Aspect** repeatedly to select an aspect ratio to suit the format of the video signal and your display requirements.
- Using the OSD menu
  1. Press **MENU** and then press **◀/▶** until the **Display** menu is highlighted.
  2. Press **▼** to highlight **Aspect Ratio**.
  3. Press **◀/▶** to select an aspect ratio to suit the format of the video signal and your display requirements.

# About the aspect ratio

 In the pictures below, the black portions are inactive areas and the white portions are active areas. OSD menus can be displayed on those unused black areas.

1. **Auto:** Scales an image proportionally to fit the projector's native resolution in its horizontal width. This is suitable for the incoming image which is neither in 4:3 nor 16:9 and you want to make most use of the screen without altering the image's aspect ratio.

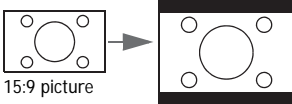

2. **Real:** The image is projected as its original resolution, and resized to fit within the display area. For input signals with lower resolutions, the projected image will display smaller than if resized to full screen. You could adjust the zoom setting or move the projector away from the screen to increase the image size if necessary. You may also need to refocus the projector after making these adjustments.

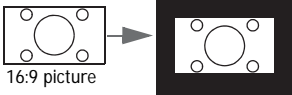

3. **4:3:** Scales an image so that it is displayed in the center of the screen with a 4:3 aspect ratio. This is most suitable for 4:3 images like computer monitors, standard definition TV and 4:3 images aspect DVD movies, as it displays them without aspect alteration.

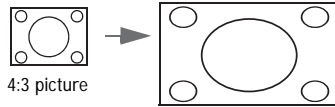

4. **16:9:** Scales an image so that it is displayed in the center of the screen with a 16:9 aspect ratio. This is most suitable for images which are already in a 16:9 aspect, like high definition TV, as it displays them without aspect alteration.

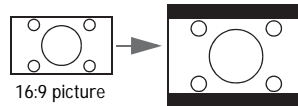

5. **16:10:** Scales an image so that it is displayed in the center of the screen with a 16:10 aspect ratio. This is most suitable for images which are already in a 16:10 aspect, as it displays them without aspect alteration.

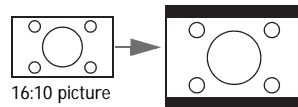

# Optimizing the image

## Using Wall Color

In the situation where you are projecting onto a colored surface such as a painted wall which may not be white, the **Wall Color** feature can help correct the projected picture's color to prevent possible color difference between the source and projected pictures.

To use this function, go to the **Display > Wall Color** menu and press ◀/▶ to select a color which is the closest to the color of the projection surface. There are several precalibrated colors to choose from: **Light Yellow, Pink, Light Green, Blue,** and **Blackboard**.

## Selecting a picture mode

The projector is preset with several predefined picture modes so that you can choose one to suit your operating environment and input signal picture type.

To select an operation mode that suits your need, you can follow one of the following steps.

- Press **ENTER** on the projector repeatedly until your desired mode is selected.
  - Go to the **Picture > Picture Mode** menu and press ◀/▶ to select a desired mode.
1. **Bright mode:** Maximizes the brightness of the projected image. This mode is suitable for environments where extra-high brightness is required, such as using the projector in well lit rooms.
  2. **Presentation mode:** Is designed for presentation. The brightness is emphasized in this mode to match PC and notebook coloring.
  3. **sRGB mode:** Maximizes the purity of RGB colors to provide true-to-life images regardless of brightness setting. It is most suitable for viewing photos taken with an sRGB compatible and properly calibrated camera, and for viewing PC graphic and drawing applications such as AutoCAD.
  4. **Vivid mode:** Is appropriate for playing colorful movies, video clips from digital cameras or DVs through the PC input for best viewing in a blackened (dimly lit) environment.
  5. **3D mode:** Is appropriate for playing 3D images and 3D video clips.
  6. **User 1/User 2 mode:** Recalls the settings customized based on the current available picture modes. See "[Setting the User 1/User 2 mode](#)" on page 34 for details.

## Setting the User 1/User 2 mode

There are two user-definable modes if the current available picture modes are not suitable for your need. You can use one of the picture modes (except the **User 1/User 2**) as a starting point and customize the settings.

1. Press **MENU** to open the On-Screen Display (OSD) menu.
2. Go to the **Picture > Picture Mode** menu.
3. Press **◀/▶** to select **User 1/User 2**.
4. Press **▼** to highlight **Reference Mode**.

 This function is only available when User 1/User 2 mode is selected up in the Picture Mode sub-menu item.

5. Press **◀/▶** to select a picture mode that is closest to your need.
6. Press **▼** to select a sub-menu item to be changed and adjust the value with **◀/▶**. See "[Fine-tuning the image quality in user modes](#)" below for details.

## Fine-tuning the image quality in user modes

According to the detected signal type, and selected picture mode, some of the functions listed below may not be available. Base on your need, you can make adjustments to these functions by highlighting them and press **◀/▶** on the projector or remote control.

### Adjusting Brightness

The higher the value, the brighter the image. And lower the setting, darker the image. Adjust this control so the black areas of the image appear just as black and that detail in the dark areas is visible.



### Adjusting Contrast

The higher the value, the greater the contrast. Use this to set the peak white level after you have previously adjusted the **Brightness** setting to suit your selected input and viewing environment.



### Adjusting Color

Lower setting produces less saturated colors. If the setting is too high, colors on the image will be overpowering, which makes the image unrealistic.

### Adjusting Tint

The higher the value, the more reddish the picture becomes. The lower the value, the more greenish the picture becomes.

### Adjusting Sharpness

The higher the value, the sharper the picture becomes. The lower the value, the softer the picture becomes.

### Adjusting Brilliant Color

This feature utilizes a new color-processing algorithm and system level enhancements to enable higher brightness while providing truer, more vibrant colors in picture. It enables a greater than 50% brightness increase in mid-tone images, which are common in video and natural scenes, so the projector reproduces images in realistic and true colors. If you prefer images with that quality, select **On**. If you don't need it, select **Off**.

When **Off** is selected, the **Color Temperature** function is not available.

## Selecting a Color Temperature

The options available for color temperature\* settings vary according to the signal type selected.

1. **Cooler:** makes the image appear bluish white.
2. **Normal:** Maintains normal colorings for white.
3. **Warm:** Makes images appear reddish white.

### \*About color temperatures:

There are many different shades that are considered to be "white" for various purposes. One of the common methods of representing white color is known as the "color temperature". A white color with a low color temperature appears to be reddish white. A white color with a high color temperature appears to have more blue in it.

## Setting a preferred color temperature

To set a preferred color temperature:

1. Highlight **Color Temperature** and select **Warm**, **Normal** or **Cool** by pressing ◀/▶ on the projector or remote control.
2. Press ▼ to highlight **Color Temperature Fine Tuning** and press **ENTER**. The Color Temperature Fine Tuning page appears.
3. Press ▲/▼ to highlight the item you want to change and adjust the values by pressing ◀/▶.
  - **R Gain/G Gain/B Gain:** Adjusts the contrast levels of Red, Green, and Blue.
  - **R Offset/G Offset/B Offset:** Adjusts the brightness levels of Red, Green, and Blue.
4. Press **MENU** to exit and save the settings.

## 3D Color Management

In most installation situations, color management will not be necessary, such as in classroom, meeting room, or lounge room situations where lights remain on, or where building external windows allow daylight into the room.

Only in permanent installations with controlled lighting levels such as boardrooms, lecture theaters, or home theaters, should color management be considered. Color management provides fine color control adjustment to allow for more accurate color reproduction, should you require it.

Proper color management can only be achieved under controlled and reproducible viewing conditions. You will need to use a colorimeter (color light meter), and provide a set of suitable source images to measure color reproduction. These tools are not provided with the projector, however, your projector supplier should be able to provide you with suitable guidance, or even an experienced professional installer.

The Color Management provides six sets (RGBCMY) of colors to be adjusted. When you select each color, you can independently adjust its range and saturation according to your preference.

If you have purchased a test disc which contains various color test patterns and can be used to test the color presentation on monitors, TVs, projectors, etc. You can project any image from the disc on the screen and enter the **3D Color Management** menu to make adjustments.

To adjust the settings:

1. Go to the **Picture** menu and highlight **3D Color Management**.
2. Press **ENTER** and the **3D Color Management** page displays.
3. Highlight **Primary color** and press ◀/▶ to select a color from among Red, Green, Blue, Cyan, Magenta and Yellow.
4. Press ▼ to highlight **Hue** and press ◀/▶ to select its range. Increase in the range will include colors consisted of more proportions of its two adjacent colors.

Please refer to the illustration to the right for how the colors relate to each other.

For example, if you select Red and set its range at 0, only pure red in the projected picture will be selected. Increasing its range will include red close to yellow and red close to magenta.

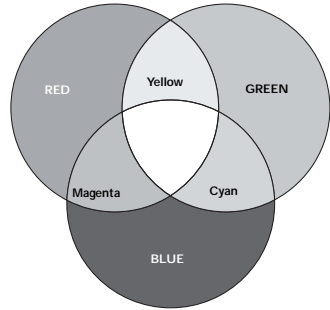

5. Press ▼ to highlight **Saturation** and adjust its values to your preference by pressing ◀/▶. Every adjustment made will reflect to the image immediately.

For example, if you select Red and set its value at 0, only the saturation of pure red will be affected.

 **Saturation is the amount of that color in a video picture. Lower settings produce less saturated colors; a setting of “0” removes that color from the image entirely. If the saturation is too high, that color will be overpowering and unrealistic.**

6. Press ▼ to highlight **Gain** and adjust its values to your preference by pressing ◀/▶. The contrast level of the primary color you select will be affected. Every adjustment made will reflect to the image immediately.
7. Repeat steps 3 to 6 for other color adjustments.
8. Make sure you have made all of the desired adjustments.
9. Press **MENU** to exit and save the settings.

### Resetting current or all picture modes

1. Go to the **Picture** menu and highlight **Reset Picture Settings**.
2. Press **ENTER** and press ▲/▼ to select **Current** or **All**.
  - **Current**: returns current picture mode to the factory preset settings.
  - **All**: returns all settings, except **User 1/User 2** in the **Picture** menu to the factory preset settings.



# Setting the presentation timer

Presentation timer can indicate the presentation time on the screen to help you achieve better time management when giving presentations. Follow these steps to utilize this function:

1. Go to the **System Setup: Basic > Presentation Timer** menu and press **ENTER** to display the **Presentation Timer** page.
2. Highlight **Timer Period** and decide the time period by pressing **◀/▶**. The length of time can be set from 1 to 5 minutes in 1-minute increments and 5 to 240 minutes in 5-minute increments.

 If the timer is already on, the timer will restart whenever the **Timer Period** is reset.

3. Press **▼** to highlight **Timer Display** and choose if you want the timer to show up on the screen by pressing **◀/▶**.

Selection	Description
<b>Always</b>	Displays the timer on screen throughout the presentation time.
<b>3 min/2 min/1 min</b>	Displays the timer on screen in the last 3/2/1 minute(s).
<b>Never</b>	Hides the timer throughout the presentation time.

4. Press **▼** to highlight **Timer Position** and set the timer position by pressing **◀/▶**.
5. Press **▼** to highlight **Timer Counting Direction** and select your desired counting direction by pressing **◀/▶**.

Selection	Description
<b>Count Up</b>	Increases from 0 to the preset time.
<b>Count Down</b>	Decreases from the preset time to 0.

6. Press **▼** to highlight **Sound Reminder** and decide if you want to activate sound reminder by pressing **◀/▶**. If you select **On**, a double beep sound will be heard at the last 30 seconds of counting down/up, and a triple beep sound will be produced when the timer is up.
7. To activate the presentation timer, press **▼** and press **◀/▶** to highlight **On** and press **ENTER**.
8. A confirmation message appears. Highlight **Yes** and press **ENTER** on the projector or remote control to confirm. You will see the message "**Timer is On**" appearing on the screen. The timer starts counting when the timer is on.

## To cancel the timer, perform the following steps:

1. Go to the **System Setup: Basic > Presentation Timer** menu and highlight **Off**. Press **ENTER**. A confirmation message appears.
2. Highlight **Yes** and press **ENTER** to confirm. You will see the message "**Timer is Off**" appearing on the screen.

# Remote paging operations

Connect the projector to your PC or notebook with a USB cable prior to using the paging function. See "[Connection](#)" on page 20 for details.

You can operate your display software program (on a connected PC) which responds to page up/down commands (like Microsoft PowerPoint) by pressing **PAGE +/PAGE -** on the remote control.

If remote paging function doesn't work, check if the USB connection is correctly made and the mouse driver on your computer is updated to the latest version.

 The remote paging function cannot work with Microsoft® Windows® 98 operating system. Windows® XP or higher operating systems are recommended.

## Freezing the image

Press **FREEZE** on the remote control to freeze the image. The word '**FREEZE**' will appear on the screen. To release the function, press any key on the projector or remote control.

 If your remote control has the following keys, please note that they cannot be pressed to release the function: **LASER, #2, #5, PAGE +/PAGE -**.

Even if an image is frozen on the screen, the pictures are running on the video or other device. If the connected devices have active audio output, you will still hear the audio even though the image is frozen on screen.

## Hiding the image

In order to draw the audience's full attention to the presenter, you can use **BLANK** on the projector or **BLANK** on the remote control to hide the screen image. When the function is activated with an audio input connected, the audio can still heard.

You can set the blank time in the **System Setup: Basic > Operating Settings > Blank Timer** menu to let the projector return the image automatically after a period of time when there is no action taken on the blank screen. The length of time can be set from 5 to 30 minutes in 5-minute increments.





If the preset time spans are not suitable for your presentation, select **Disable**.

No matter **Blank Timer** is activated or disabled, you can press most of the keys on the projector or remote control to restore the picture.

 **Do not block the projection lens from projecting as this could cause the blocking object to become heated and deformed or even cause a fire.**

# Locking control keys

With the control keys on the projector locked, you can prevent your projector settings from being changed accidentally (by children, for example). When the **Panel Key Lock** is on, no control keys on the projector will operate except  **POWER**.

1. Go to the **System Setup: Basic > Panel Key Lock** menu, and select **On** by pressing   on the projector or remote control. A confirmation message appears.
2. Highlight **Yes** and press **ENTER** to confirm.  
To release panel key lock, use the remote control to enter the **System Setup: Basic > Panel Key Lock** menu and press   to select **Off**.



• Keys on the remote control are still active when panel key lock is enabled.

- If you press  **POWER** to turn off the projector without disabling panel key lock, the projector will still be in locked status the next time it is turned on.





# Operating in a high altitude environment

We recommend you use the **High Altitude Mode** when your environment is between 1500 m – 3000 m above sea level, and temperature is between 0°C – 30°C.



**Do not use the High Altitude Mode if your altitude is between 0 m and 1500 m and temperature is between 0°C and 35°C. The projector will be over cooled, if you turn the mode on under such a condition.**

To activate the **High Altitude Mode**:

1. Press **MENU** and then press   until the **System Setup: Advanced** menu is highlighted.
2. Press  to highlight **High Altitude Mode** and press   to select **On**. A confirmation message displays.
3. Highlight **Yes** and press **ENTER**.

Operation under "**High Altitude Mode**" may cause a higher decibel operating noise level because of increased fan speed necessary to improve overall system cooling and performance.

If you use this projector under other extreme conditions excluding the above, it may display auto shut-down symptoms, which is designed to protect your projector from over-heating. In cases like this, you should switch to High Altitude mode to solve these symptoms. However, this is not to state that this projector can operate under any and all harsh or extreme conditions.

# Adjusting the sound

The sound adjustments made as below will have an effect on the projector speakers. Be sure you have made a correct connection to the projector audio input. See "[Connection](#)" on page 20 for how the audio input is connected.

INPUT SOURCE	AUDIO IN	AUDIO OUT
COMPUTER-1	AUDIO IN-1	mini jack
COMPUTER-2, COMPUTER-3, DVI-D	AUDIO IN-2	mini jack
COMPONENT	AUDIO IN-3	mini jack
S-VIDEO, VIDEO	AUDIO IN-4	mini jack
HDMI	HDMI	mini jack
DISPLAY PORT	DISPLAY PORT	mini jack

## Muting the sound

To temporarily turn off the sound,

- Using the remote control

Press **MUTE** to temporarily turn off the sound. While the sound is off, the screen will display  in the upper right corner of the screen.

To restore the sound, press **MUTE** again.

- Using the OSD menu

1. Press **MENU** and then press **◀/▶** until the **System Setup: Advanced** menu is highlighted.
2. Press **▼** to highlight **Audio Settings** and press **ENTER**. The **Audio Settings** page displays.
3. Highlight **Mute** and press **◀/▶** to select **On**.
4. To restore the sound, repeat steps 1-3 and press **◀/▶** to select **Off**.

## Adjusting the sound level

To adjust the sound level,

- Using the remote control

Press **VOLUME+/VOLUME-** to select a desired sound level.

- Using the OSD menu

1. Repeat steps 1-2 above.
2. Press **▼** to highlight **Volume** and press **◀/▶** to select a desired sound level.

## Turning off the Power on/off ring tone

1. Repeat steps 1-2 above.
2. Press **▼** to highlight **Power on/off ring tone** and press **◀/▶** to select **Off**.

The only way to change Power on/off ring tone is setting On or Off here. Setting the sound mute or changing the sound level will not affect the Power on/off ring tone.

# Using the test pattern

The projector comes with some standard built-in patterns for testers to calibrate the equipment.

The options are **Grid, White, Red, Green, Blue, Black, RGB Ramps, Color Bar, Step Bars, CheckBoard, Horizontal Lines, Vertical Lines, Diagonal Lines, Horizontal Ramp, Vertical Ramps** and **Off**.

To display the test pattern, open the OSD menu and go to the **System Setup: Advanced > Test Pattern** and press ◀/▶ to select.

# Using the quick install

The projector provides a hot key to set **Projector Installation, Test Pattern, and Keystone** quickly.

Press **Quick Install** on the remote control and press ▲/▼ to select:

- Projector Installation: See ["Positioning your projector" on page 14](#).
- Test Pattern: See ["Using the test pattern" on page 41](#).
- Keystone: See ["Correcting Keystone" on page 25](#).

# 3D Sync connection

- In: Connect 3D-sync in cable from a computer or an enabled device.
- Out: Connect 3D IR glasses receiver unit.

# Shutting down the projector

1. Press **POWER** or **OFF** and a confirmation message will appear prompting you.  
If you don't respond in a few seconds, the message will disappear.
2. Press **POWER** or **OFF** a second time. The **POWER indicator light** flashes orange, the projection lamp shuts down, and the fans will continue to run for approximately 90 seconds to cool down the projector.



To protect the lamp, the projector will not respond to any commands during the cooling process. To shorten the cooling time, you can also activate the Quick Cooling function. See ["Quick Cooling" on page 50](#) for details.

3. Once the cooling process finishes, a **"Power Off Ring Tone"** will be heard. The **POWER indicator light** is a steady orange and fans stop. Disconnect the power cord from the power outlet.



To turn off the power ring tone, see ["Turning off the Power on/off ring tone" on page 40](#) for details.

- If the projector is not properly shut down, to protect the lamp, when you attempt to re-start the projector, the fans will run for a few minutes to cool down. Press **POWER** or **ON** again to start the projector after the fans stop and the **POWER indicator light** turns orange.
- Lamp life results will vary depending on environmental conditions and usage.

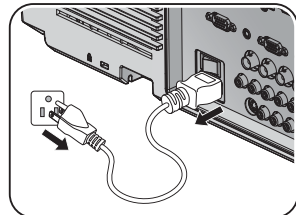

# Menu operation

## Menu system

Please note that the on-screen display (OSD) menus vary according to the signal type selected.

Main menu	Sub-menu	Options	
1. Display	Wall color	Off/Light Yellow/Pink/Light Green/Blue/Blackboard	
	Aspect Ratio	Auto/Real/4:3/16:9/16:10	
	Keystone		
	Position		
	Phase		
	H.size		
	Digital zoom	PC: 0.8X~2.0X; Video: 0.8X~1.8X	
	Overscan	Composite/S-Video: 0- 3; others: 0-3	
	3D	3D Sync Mode	DLP Link/VESA 3D
		3D mode	Auto/Off/Frame sequential/Frame packing/Top bottom/Side by side
		3D Sync Invert	Disable/Invert
		Save 3D Setting	3D Settings 1/3D Settings 2/3D Settings 3
		Apply 3D Setting	3D Settings 1/3D Settings 2/3D Settings 3/Off
		3D sync out delay	0~359

<b>Main menu</b>	<b>Sub-menu</b>	<b>Options</b>	
<b>2. Picture</b>	Picture Mode	Bright/Presentation/sRGB/Vivid/ 3D/User 1/User 2	
	Reference Mode	Bright/Presentation/sRGB/Vivid/3D	
	Brightness		
	Contrast		
	Color		
	Tint		
	Sharpness		
	Brilliant Color	On/Off	
	Color Temperature	Cool/Normal/Warm	
	Color Temperature Fine Tuning	R Gain/G Gain/B Gain/ R Offset/G Offset/B Offset	
	3D Color Management	Primary Color	R/G/B/C/M/Y
		Hue	
		Saturation	
		Gain	
Reset picture settings	Current/All/Cancel		
<b>3. Source</b>	Quick Auto Search	On/Off	
	Color Space Conversion	Auto/RGB/YUV	
	Auto Sync	On/Off	

Main menu	Sub-menu	Options	
Presentation Timer	Timer Period	1~15~240 min	
	Timer Display	Always/1 min/2 mins/3 mins/Never	
	Timer Position	Top-Left/Bottom-Left/ Top-Right/Bottom-Right	
	Timer Counting Direction	Count Down/Count up	
	Sound Reminder	On/Off	
	On	Yes/No	
	Off	Yes/No	
Language		English / Français / Deutsch / Italiano / Español / Русский / 繁體中文 / 简体中文 / 日本語 / 한국어 / Svenska / Nederlands / Türkçe / Čeština / Português / हिन्दी / Polski / Magyar / Hrvatski / Română / Norsk / Dansk / Български / Suomi / Indonesian / Ελληνικά / العربية / हिन्दी	
	Projector Installation	Front/Rear/Rear Ceiling/Front Ceiling	
4. System Setup: Basic	Menu Setting	Menu Display Time	5 sec/10 sec/20 sec/30 sec/Always
		Menu Position	Center/Top-Left/Top-Right/ Bottom-Right/Bottom-Left
	Operation Setting	Reminder Message	On/Off
		Direct Power On	On/Off
Signal Power On		On/Off	
Auto Power Off		Disable/3 mins/10 mins/15 mins/ 20 mins/25 mins/30 mins	
Quick Cooling		On/Off	
Blank Timer		Disable/5 mins/10 mins/ 15 mins/20 mins/25 mins/ 30 mins	
Sleep Timer		Disable/30 mins/1 hr/2 hrs/3 hrs/4 hrs/8 hrs/12 hrs	
Reset Filter Timer	Reset/Cancel		
Remote Receiver	Front+Rear/Front/Rear		
Panel Key Lock	On/Off		
Background Color	BenQ/Black/Blue/Purple		
Splash Screen	BenQ/Black/Blue		



Main menu	Sub-menu	Options
	High Altitude Mode	On/Off
		Mute
		On/Off
	Audio Settings	Volume
		Power on/off Ring
		On/Off
		Lamp Mode
		Normal/Economic
	Lamp Settings	Reset Lamp Timer
		Reset/Cancel
		Lamp Information
		Change Password
	Security Setting	Change Security Settings
		Power On Lock
		On/Off
	Baud Rate	2400/4800/9600/14400/19200/ 38400/57600/115200
	Test Pattern	Off/Grid/White/Red/Green/Blue/ Black/RGB Ramps/Color Bar/Step Bars/CheckBoard/Horizontal Lines/Vertical Lines/Diagonal Lines/ Horizontal Ramp/Vertical Ramps
	Projector ID Setting	Off/01~99
		Closed Caption Enable
		On/Off
	Closed Caption	Caption Version
		CC1 / CC2 / CC3 / CC4
	12V Trigger	On/Off
		Enable Network Standby Mode/ Auto Disable Network Standby Mode
	Standby Settings	Network
		Monitor Out
		On/Off
		Audio Pass Through
		Audio In 1/Audio In 2/Audio In 3/ Audio L/R /HDMI/Off
		Status
		DHCP
		IP Address
		Subnet Mask
		Default Gateway
		DNS Server
		Apply
	Network settings	Wired LAN
		AMX Device Discovery
		On/Off
		Mac Address
	Reset All Settings	Reset/Cancel

## 5. System Setup: Advanced

Main menu	Sub-menu	Options
<b>6. Information</b>	Current System Status	<ul style="list-style-type: none"> <li>• Source</li> <li>• Picture Mode</li> <li>• Lamp Mode</li> <li>• Resolution</li> <li>• 3D Format</li> <li>• Color System</li> <li>• Lamp Usage Time</li> <li>• Projector ID</li> <li>• Firmware Version</li> </ul>

Note that the menu items are available when the projector detects at least one valid signal. If there is no equipment connected to the projector or no signal detected, limited menu items are accessible.

# Description of each menu

		FUNCTION	DESCRIPTION	
1. Display menu	<b>Wall color</b>		Corrects the projected picture's color when the projection surface is not white. See <a href="#">"Using Wall Color" on page 33</a> for details.	
	<b>Aspect Ratio</b>		There are several options to set the image's aspect ratio depending on your input signal source. See <a href="#">"Selecting the aspect ratio" on page 31</a> for details.	
	<b>Keystone</b>		Adjusts the shape of the projected image to ensure straight lines on all four corners. See <a href="#">"Correcting Keystone" on page 25</a> for details.	
	<b>Position</b>		Displays the position adjustment page. To move the projected image, use the directional arrow keys. The values shown on the lower position of the page change with every key press you made until they reach their maximum or minimum.  This function is only available when a PC signal (analog RGB) is selected.	
	<b>Phase</b>		Adjusts the clock phase to reduce image distortion. This function is only available when a PC signal (analog RGB) is selected.	
	<b>H.size</b>		Adjusts the horizontal width of the image. This function is only available when a PC signal (analog RGB) is selected.	
	<b>Digital zoom</b>		Magnifies or reduces the projected image. See <a href="#">"Magnifying and searching for details" on page 31</a> for details.	
	<b>Overscan</b>		Mask off a few pixels on each edge of the image to be displayed. Use the function to adjust if image source happens to have noise near any edge of the display image.	

## FUNCTION

## DESCRIPTION

### 3D

This projector features a 3D function which enables you to enjoy the 3D movies, videos, and sporting events in a more realistic way by presenting the depth of the images. You need to wear a pair of 3D glasses to view the 3D images.

#### 3D Sync Mode

Select DLP-Link or 3D VESA for DLP-Link or 3D VESA glasses.

#### 3D Mode

The default setting is **Auto** and the projector automatically chooses an appropriate 3D format when detecting 3D contents. If the projector cannot recognize the 3D format, press ◀/▶ to choose a 3D mode.



When the 3D function is on:

- The brightness level of the projected image will decrease.
- The following settings cannot be adjusted: Picture Mode, Reference Mode.
- The Keystone can only be adjusted within limited degrees.

#### 3D Sync Invert

When you discover the inversion of the image depth, enable this function to correct the problem.

#### Save 3D Settings

When you have successfully displayed the 3D contents after making the appropriate adjustments, you can enable this function and choose a set of 3D settings to memorize current 3D settings.

#### Apply 3D Settings





After the 3D settings are saved, you can decide if you would like to apply them by choosing a set of 3D settings that you have saved. Once applied, the projector will automatically play the incoming 3D contents if it matches the 3D settings saved.



Only the set(s) of 3D settings with memorized data is available.

#### 3D sync out delay

Press ◀/▶ to adjust 3D sync out signal delay.



	FUNCTION	DESCRIPTION
2. Picture menu	Picture Mode	Pre-defined picture modes are provided so you can optimize your projector image set-up to suit your program type. See <a href="#">"Selecting a picture mode" on page 33</a> for details.
	Reference Mode	Selects a picture mode that most suits your need for the image quality and further fine-tune the image based on the selections listed on the same page below. See <a href="#">"Setting the User 1/User 2 mode" on page 34</a> for details.
	Brightness	Adjusts the brightness of the image. See <a href="#">"Adjusting Brightness" on page 34</a> for details.
	Contrast	Adjusts the degree of difference between dark and light in the image. See <a href="#">"Adjusting Contrast" on page 34</a> for details.
	Color	Adjusts the color saturation level -- the amount of each color in a video image. See <a href="#">"Adjusting Color" on page 34</a> for details.  The function is only available when Video or S-Video with NTSC system is selected.
	Tint	Adjusts the red and green color tones of the image. See <a href="#">"Adjusting Tint" on page 34</a> for details.  The function is only available when Video or S-Video with NTSC system is selected.
	Sharpness	Adjusts the image to make it look sharper or softer. See <a href="#">"Adjusting Sharpness" on page 34</a> for details.  The function is only available when Video or S-Video with NTSC system is selected.
	Brilliant Color	Adjusts white peaking while maintaining correct color presentation. See <a href="#">"Adjusting Brilliant Color" on page 34</a> for details.
	Color Temperature	See <a href="#">"Selecting a Color Temperature" on page 35</a> for details.
	Color Temperature Fine Tuning	See <a href="#">"Setting a preferred color temperature" on page 35</a> for details.
	3D Color Management	See <a href="#">"3D Color Management" on page 35</a> for details.
Reset picture settings	See <a href="#">"Resetting current or all picture modes" on page 36</a> for details.	
3. Source menu	Quick Auto Search	See <a href="#">"Switching input signal" on page 30</a> for details.
	Color Space Conversion	See <a href="#">"Changing Color Space" on page 30</a> for details.
	Auto Sync	Enable or disable auto sync function.  The function is only available Computer 1, Computer 2 or Computer3 (5BNC).

FUNCTION	DESCRIPTION
<b>Presentation Timer</b>	Reminds the presenter to finish the presentation within a certain time frame. See <a href="#">"Setting the presentation timer" on page 37</a> for details.
<b>Language</b>	Sets the language for the On-Screen Display (OSD) menus. See <a href="#">"Using the menus" on page 26</a> for details.
<b>Projector Installation</b>	The projector can be installed on a ceiling or behind a screen, or with one or more mirrors. See <a href="#">"Choosing a location" on page 14</a> for details.
<b>Menu Setting</b>	<b>Menu display time</b> Sets the length of time the OSD will remain active after your last key press. The range is from 5 to 30 seconds in 5-second increments.
	<b>Menu Position</b> Sets the On-Screen Display (OSD) menu position.  <b>Reminder Message</b> Selecting <b>On</b> allows the projector to remind you to clean the filter.
<b>Operation Setting</b>	<b>Direct Power On</b> Powers projector on automatically when the power cable is connected.
	<b>Signal Power On</b> Sets whether to turn the projector directly on without pressing <b>POWER</b> or <b>ON</b> when the projector is in standby mode and the signal is feed through the VGA cable.
	<b>Auto Power Off</b> Allows the projector to turn off automatically if no input signal is detected after a set period of time. See <a href="#">"Setting Auto Power Off" on page 56</a> for details.
	<b>Quick Cooling</b> Enables or disables the <b>Quick Cooling</b> function. Selecting <b>On</b> enables the function and the projector cooling time will be shortened from a normal 90 second duration to approximately 2 seconds.   <b>If you attempt to restart the projector right after the quick cooling process, it may not be turned on successfully and will rerun its cooling fans.</b>
	<b>Blank Timer</b> Sets the image blank time when the Blank feature is activated, once elapsed the image will return to the screen. See <a href="#">"Hiding the image" on page 38</a> for details.  <b>Sleep Timer</b> Sets the auto-shutdown timer. The timer can be set to a value between 30 minutes and 12 hours.  <b>Reset Filter Timer</b> Reset filter timer when the filter is replaced.

	FUNCTION	DESCRIPTION
4. System Setup: Basic menu	<b>Remote Receiver</b>	Sets the preferred remote receiver (Front and Rear) allowing the projector to accept signals from the remote control.
	<b>Panel Key Lock</b>	Disables or enables all panel key functions except <b>POWER</b> on the projector and keys on the remote control. See " <a href="#">Locking control keys</a> " on page 39 for details.
	<b>Background Color</b>	Selects background appearance when there is no signal.
	<b>Splash Screen</b>	Allows you to select which logo screen will appear during projector start-up
5. System Setup: Advanced menu	<b>High Altitude Mode</b>	A mode for operation in high altitude areas. See " <a href="#">Operating in a high altitude environment</a> " on page 39 for details.
	<b>Audio Settings</b>	See " <a href="#">Adjusting the sound</a> " on page 40 for details. <b>Mute</b> Sets the mute function. <b>Volume</b> Adjusts the audio volume level. <b>Power on/off Ring Tone</b> Sets the power on/off ring tone.
	<b>Lamp Settings</b>	<b>Lamp Mode</b> See " <a href="#">Setting Lamp mode as Economic</a> " on page 56 for details. <b>Reset lamp timer</b> See " <a href="#">Resetting the lamp timer</a> " on page 60 for details. <b>Lamp Information</b> See " <a href="#">Getting to know the lamp hour</a> " on page 56 for details on how the total lamp hour is calculated.

FUNCTION		DESCRIPTION
5. System Setup: Advanced menu	<b>Security Setting</b>	<p><b>Change password</b> You will be asked to enter the current password before changing to a new one. See "<a href="#">Utilizing the password function</a>" on page 27 for details.</p> <p><b>Change Security Settings</b></p> <p><b>Power On Lock</b> When <b>Power On Lock</b> is activated, you will be asked to enter the current password before powering on the projector.</p> <p>If you enter incorrect password 5 times in succession, the projector will automatically shut down in a short time.</p>
	<b>Baud Rate</b>	Selects a baud rate that is identical with your computer's so that you can connect the projector using a suitable RS-232 cable and update or download the projector's firmware. This function is intended for qualified service personnel.
	<b>Test Pattern</b>	<p>The projector comes with some standard built-in patterns for testers to calibrate the equipment.</p> <p>The options are <b>Grid, White, Red, Green, Blue, Black, RGB Ramps, Color Bar, Step Bars, CheckBoard, Horizontal Lines, Vertical Lines, Diagonal Lines, Horizontal Ramp, Vertical Ramps</b> and <b>Off</b>.</p>
	<b>Projector ID Setting</b>	<p>Disables or enables the projector ID function.</p> <p> The remote control number must match the projector number for accurate control.</p>
	<b>Closed Caption</b>	<p><b>Closed Caption Enable</b> Activates the function by selecting On when the selected input signal carries closed captions.</p> <ul style="list-style-type: none"> <li>Captions: An on-screen display of the dialogue, narration, and sound effects of TV programs and videos that are closed captioned (usually marked as "CC" in TV listings).</li> </ul> <p><b>Caption Version</b> Selects a preferred closed captioning mode. To view captions, select CC1, CC2, CC3, or CC4 (CC1 displays captions in the primary language in your area).</p>
	<b>12V Trigger</b>	Enable or disable 12V Trigger output.



FUNCTION	DESCRIPTION
<p style="writing-mode: vertical-rl; transform: rotate(180deg);">5. System Setup: Advanced menu</p> <p>Standby Settings</p>	<p><b>Network</b></p> <ul style="list-style-type: none"> <li>• <b>Enable Network Standby Mode</b> Selecting On enables the function. The projector is able to provide the network function in standby mode. Selecting Off disables the function. The projector does not provide the network function in standby mode.</li> <li>• <b>Auto Disable Network Standby Mode</b> Allows the projector to disable the network function after a set period of time after it enters standby mode. For instance, if 20 min is selected, the projector is able to provide the network function for 20 minutes after it enters standby mode. When 20 minutes is up, the projector enters normal standby mode.</li> </ul> <p> This function is only available when Enable Network Standby Mode is On.</p> <p><b>Monitor Out</b> Selecting On enables the function. The projector can output a VGA signal when it is in standby mode and the COMPUTER 1 jack is correctly connected to devices. See "Connection" on page 20 for how to make the connection.</p> <p><b>Audio Pass Through</b> Press ◀/▶ to choose the source that you wish to use in operation mode. See "Connection" on page 20 for how to make the connection.</p> <p>When the corresponding jacks are correctly connected to the device, the projector can output an audio signal to the external speaker when it is in standby mode.</p> <p> Enabling this function slightly increases the standby power consumption.</p>
<p>Network settings</p>	<p><b>Wired LAN</b> See <a href="#">BenQ Network Projector Operation Guide</a> for details.</p> <p><b>AMX Device Discovery</b> When <b>AMX Device Discovery</b> is <b>On</b>, the projector can be detected by AMX controller.</p> <p><b>MAC Address</b> Displays the <b>MAC Address</b> for this projector.</p>
<p>Reset All Settings</p>	<p>Returns all settings to the factory preset values.</p> <p> The following settings will still remain: Position, Phase, H. Size, Projector Installation, Language, High Altitude Mode, Security Settings, Baud Rate.</p>

FUNCTION		DESCRIPTION
6. Information menu	Current System Status	<b>Source</b> Shows the current signal source.
		<b>Picture Mode</b> Shows the selected mode in the <b>Picture</b> menu.
		<b>Lamp Mode</b> Shows the current lamp mode.
		<b>Resolution</b> Shows the native resolution of the input signal.
		<b>3D Format</b> Shows the current 3D mode.
		<b>Color System</b> Shows input system format, NTSC, PAL, SECAM or RGB.
		<b>Lamp Usage Time</b> Displays the number of hours the lamp has been used.
		<b>Projector ID</b> Shows the selected projector ID in the <b>System Setup: Advanced</b> menu.
		<b>Firmware Version</b> Displays the firmware version of the projector.

 The Information menu shows you the current operating status of the projector.

# Maintenance

## Care of the projector

Your projector needs little maintenance. The only thing you need to do on a regular basis is to keep the lens clean.

Never remove any parts of the projector except the lamp. Contact your dealer if other parts need replacing.

### Cleaning the lens

Clean the lens whenever you notice dirt or dust on the surface.

- Use a canister of compressed air to remove dust.
- If there is dirt or smears, use lens-cleaning paper or moisten a soft cloth with lens cleaner and gently wipe the lens surface.

 **Never use any type of abrasive pad, alkaline/acid cleaner, scouring powder, or volatile solvent, such as alcohol, benzene, thinner or insecticide. Using such materials or maintaining prolonged contact with rubber or vinyl materials may result in damage to the projector surface and cabinet material.**

### Cleaning the projector case

Before you clean the case, turn the projector off using the proper shutdown procedure as described in "[Shutting down the projector](#)" on page 41 and unplug the power cord.

- To remove dirt or dust, wipe the case with a soft, lint-free cloth.
- To remove stubborn dirt or stains, moisten a soft cloth with water and a neutral pH detergent. Then wipe the case.

 **Never use wax, alcohol, benzene, thinner or other chemical detergents. These can damage the case.**

### Storing the projector

If you need to store the projector for an extended time, please follow the instructions below:

- Make sure the temperature and humidity of the storage area are within the recommended range for the projector. Please refer to "[Specifications](#)" on page 65 or consult your dealer about the range.
- Retract the adjuster feet.
- Remove the battery from the remote control.
- Pack the projector in its original packing or equivalent.

### Transporting the projector

It is recommended that you ship the projector with its original packing or equivalent. When you carry the projector yourself, please use the original box or a suitable soft carry case.

# Lamp information

## Getting to know the lamp hour

When the projector is in operation, the duration (in hours) of lamp usage is automatically calculated by the built-in timer.

To obtain the lamp hour information:

1. Press **MENU** and then press ◀/▶ until the **SYSTEM SETUP: Advanced** menu is highlighted.
2. Press ▼ to highlight **Lamp Settings** and press **ENTER**. The **Lamp Settings** page displays.
3. You will see the **Lamp Information** information displaying on the menu.
4. To leave the menu, press **MENU**.

You can also get the **Lamp Usage Time** on the **INFORMATION** menu.

## Extending lamp life

The projection lamp is a consumable item. To keep the lamp life as long as possible, you can do the following settings via the OSD menu.

### Setting Lamp mode as Economic

Using **Economic** mode reduces system noise and power consumption by 20%. If the **Economic** mode is selected, the light output will be reduced and result in darker projected pictures.

Setting the projector in **Economic** mode also extends the lamp operation life. To set **Economic** mode, go into the **SYSTEM SETUP: Advanced > Lamp Settings > Lamp mode** menu and press ◀/▶ until your desired mode is selected.

Lamp mode	Description
<b>Normal</b>	100% lamp brightness
<b>Economic</b>	Saves 20% lamp power consumption.

### Setting Auto Power Off

This function allows the projector to turn off automatically if no input source is detected after a set period of time to prevent unnecessary waste of lamp life.

To set **Auto Power Off**, go into the **SYSTEM SETUP: Basic > Auto Power Off** menu and press ◀/▶. The time period can be set from 5 to 30 minutes in 5-minute increments. If the preset time lengths are not suitable for your presentation, select **Disable**. The projector will not automatically shut down in a certain time period.

# Timing of replacing the lamp



When the **Lamp indicator** lights up red or a message appears suggesting it is time to replace the lamp, please install a new lamp or consult your dealer. An old lamp may cause a malfunction in the projector and in some instances the lamp may explode.

Go to <http://www.benq.com> for a replacement lamp.

 **The Lamp indicator light and Temperature warning light will light up if the lamp becomes too hot. Turn the projector off and let the projector cool for 45 minutes. If the lamp or Temp indicator still lights up after turning the power back on, please contact your dealer. See "Indicators" on page 62 for details.**

The following lamp warning displays will remind you to change the lamp.

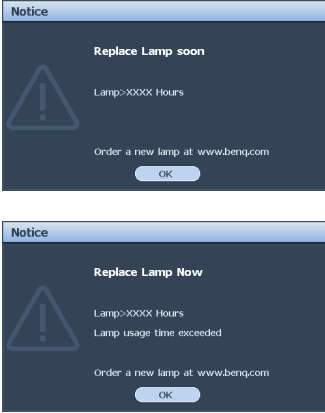
 **The warning messages below are for reference only. Please follow the actual on-screen instructions to prepare and replace the lamp.**

Status	Message
<p>Install a new lamp for optimal performance. If the projector is normally run with <b>Economic</b> selected (See "<a href="#">Setting Lamp mode as Economic</a>" on page 56), you may continue to operate the projector until the next lamp warning appears.</p> <p>Press <b>ENTER</b> to dismiss the message.</p>	 <p>The screenshot shows a dark blue background with a white 'Notice' header. Below the header is a large white exclamation mark icon. The text reads: 'Order Replacement Lamp', 'Lamp&gt;XXXX Hours', and 'Order a new lamp at www.benq.com'. At the bottom is a white 'OK' button.</p>
<p>It is strongly recommended that you replace the lamp at this age. The lamp is a consumable item. The lamp brightness diminishes with use. This is normal lamp behavior. You can replace the lamp whenever you notice that the brightness level has significantly diminished.</p> <p>Press <b>ENTER</b> to dismiss the message.</p>	 <p>Two screenshots are shown. The top one is titled 'Replace Lamp soon' and the bottom one is titled 'Replace Lamp Now'. Both have a white exclamation mark icon and text: 'Lamp&gt;XXXX Hours', 'Order a new lamp at www.benq.com', and an 'OK' button. The 'Replace Lamp Now' message also includes the text 'Lamp usage time exceeded'.</p>
<p>The lamp <b>MUST</b> be replaced before the projector will operate normally.</p> <p>Press <b>ENTER</b> to dismiss the message.</p>	 <p>The screenshot shows a dark blue background with a white 'Notice' header. Below the header is a large white exclamation mark icon. The text reads: 'Out of Lamp Usage Time', 'Replace lamp (Refer to user manual). Then reset lamp timer', and 'Order a new lamp at www.benq.com'. At the bottom is a white 'OK' button.</p>

# Replacing the lamp



- If lamp replacement is performed while the projector is suspended upside-down from the ceiling, make sure that no one is underneath the lamp socket to avoid any possible injury or damage to the human eyes caused by fractured lamp.

- To reduce the risk of electrical shock, always turn the projector off and disconnect the power cord before changing the lamp.

- To reduce the risk of severe burns, allow the projector to cool for at least 45 minutes before replacing the lamp.

- To reduce the risk of injuries to fingers and damage to internal components, use caution when removing lamp glass that has shattered into sharp pieces.

- To reduce the risk of injuries to fingers and/or compromising image quality by touching the lens, do not touch the empty lamp compartment when the lamp is removed.

- This lamp contains mercury. Consult your local hazardous waste regulations to dispose of this lamp in a proper manner.

- To assure optimal performance from the projector, it is recommended that you purchase a BenQ projector lamp for lamp replacement.

- Ensure good ventilation when handling broken lamps. We recommend that you use respirators, safety glasses, goggles or face shield and wear protective clothing such as gloves.

1. Turn the power off and disconnect the projector from the wall socket. If the lamp is hot, avoid burns by waiting for approximately 45 minutes until the lamp has cooled.

2. Loosen the captive screw from the left side.

3. Remove the lamp compartment cover as shown.

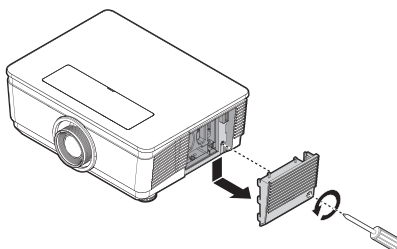

4. Loosen the two captive screws that secure the lamp.



- Do not turn the power on with the lamp cover removed.

- Do not insert your fingers between the lamp and the projector. The sharp edges inside the projector may cause injuries.

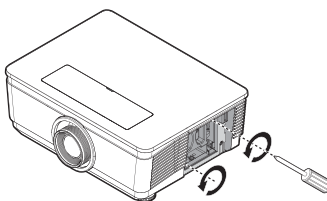

5. Slowly pull the lamp out of the projector.



- Pulling it too quickly may cause the lamp to break and scatter broken glass in the projector.
- Do not place the lamp in locations where water might splash on it, children can reach it, or near flammable materials.
- Do not insert your hands into the projector after the lamp is removed. If you touch the optical components inside, it could cause color unevenness and distortion of the projected images.

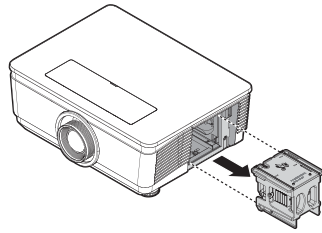

6. Insert the new lamp into the lamp compartment and make sure it fits in the projector.



- Ensure the connectors are aligned.
- If you experience resistance, lift the lamp and start again.

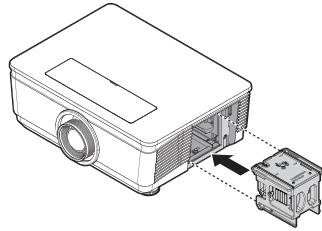

7. Tighten the screws that secure the lamp.



- Loose screw may cause a bad connection, which could result in malfunction.
- Do not over tighten the screw.

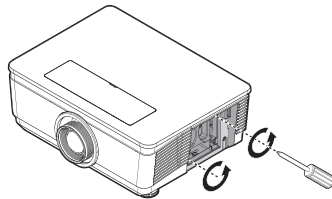

8. Replace the lamp compartment cover on the projector and tighten the captive screw.

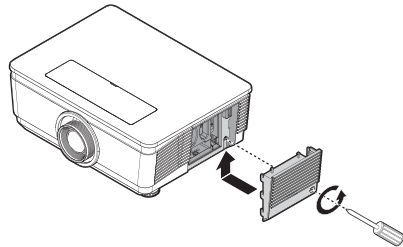

9. Restart the projector.



- Do not turn the power on with the lamp cover removed.

## Resetting the lamp timer

10. After the startup logo, open the On-Screen Display (OSD) menu. Go to the **SYSTEM SETUP: Advanced > Lamp Settings** menu. Press **ENTER**. The **Lamp Settings** page displays. Highlight **Reset lamp timer**. A warning message displays asking if you want to reset the lamp timer. Highlight **Yes** and press **ENTER**. The lamp time will be reset to '0'.



Do not reset if the lamp is not new or replaced as this could cause damage.

## Cleaning the filter

The air filter prevents dust from accumulating on the surface of the optical elements inside the projector. If the filter is dirty or clogged, your projector may overheat or degrading the projected image quality.

1. Turn off the projector, and unplug the AC power cord from the AC outlet.
2. Cleaning the filter with a vacuum cleaner.



Recommend avoiding dusty or smoky environments when you operate the projector, it may cause poor image quality. If the filter is heavily clogged and unable to clean, replace a new filter.



Using a ladder is recommended to access the filter. Do not remove the projector from the wall mount.

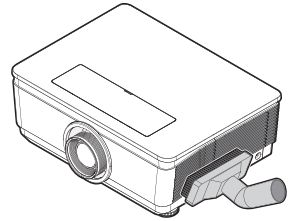

## Replacing the filter

1. Turn off the projector, and unplug the AC power cord from the AC outlet. Clean up the dust on the projector and around the air vents. Pull out the filter cover and remove from the projector.
2. Lift the filter from the filter cover.

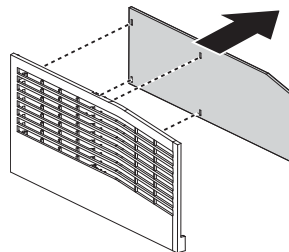
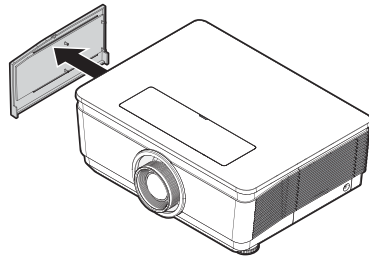



3. Replace a new filter module or replace filter into cover.

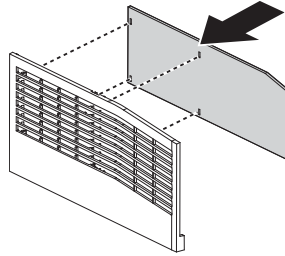

4. Replace the filter cover back to the projector by pushing gently in the direction shown.

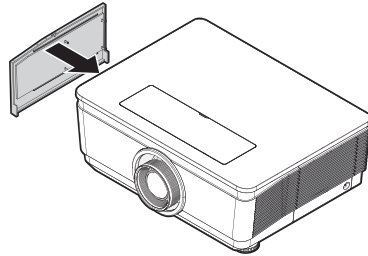

- Do not wash the filter with the water or other liquid matter.
- When the lamp is replaced, the filter should also be replaced, not cleaned.

### Resetting the filter timer

5. After the startup logo, open the On-Screen Display (OSD) menu. Go to the **SYSTEM SETUP: Basic > Operation Settings** menu. Press **ENTER**. The **Operation Settings** page displays. Highlight **Reset Filter Timer**. A warning message displays asking if you want to reset the filter timer. Highlight **Reset** and press **ENTER**. The filter time will be reset to '0'.

### Cooling notice

Allow at least 500 mm (19.7 in) for clearance around the exhaust vent. Make sure no objects block air input within 300 mm (11.8in).

Keep the outlet at least 1 m away from the inlets of other projectors.

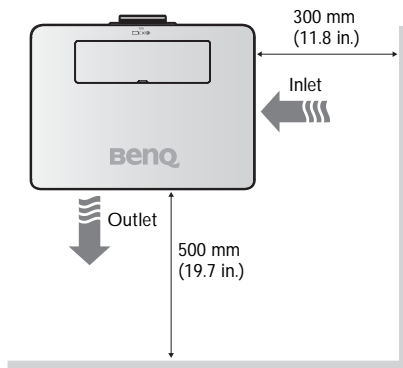

# Indicators

Light			Status & Description	
Power	Temp	Lamp		
<b>Power events</b>				
Orange	Off	Off	Stand-by mode	
Green Flashing	Off	Off	Powering up	
Green	Off	Off	Normal operation	
Orange Flashing	Off	Off	Projector is cooling.	
<b>Lamp events</b>				
Off	Off	Orange Flashing	The lamp ignition is not lit up.	
Off	Off	Red	1. The projector needs 90 seconds to cool down. <b>Or</b> 2. Please contact your dealer for assistance.	
<b>Thermal events</b>				
Red	Red	Off	The fans are not working.	The projector has shutdown automatically. If you try to re-start the projector, it will shutdown again. Please contact your dealer for assistance.
Red	Red Flashing	Off		
Red	Green	Off		
Red	Green Flashing	Off		
Red Flashing	Red	Off		
Red Flashing	Red Flashing	Off		
Green	Red	Off	Temperature 1 error (over limited temperature).	
Green	Red Flashing	Off	Thermal sensor 1 open error.	
Green	Green	Off	Thermal sensor 1 short error.	
Green	Green Flashing	Off	Thermal IC #1 I2C connection error.	
Green	Red	Red	Thermal break error.	

## System events

<b>Green</b>	<b>Off</b>	<b>Red</b>	The projector has shutdown automatically. If you try to restart the projector, it will shutdown again. Please contact your dealer for assistance.
<b>Red Flashing</b>	<b>Off</b>	<b>Off</b>	
<b>Red</b>	<b>Off</b>	<b>Red</b>	
<b>Off</b>	<b>Green</b>	<b>Red</b>	Lamp door is open. Please check if the lamp door is open or not closed properly.
<b>Green</b>	<b>Off</b>	<b>Orange</b>	Lamp life exhausted.
<b>Red</b>	<b>Off</b>	<b>Off</b>	Download.
<b>Off</b>	<b>Red</b>	<b>Off</b>	LAN download fail.
<b>Off</b>	<b>Green</b>	<b>Off</b>	LAN download processing.

# Troubleshooting

## ⑦ The projector does not turn on.

Cause	Remedy
There is no power from the power cable.	Plug the power cord into the AC inlet on the projector, and plug the power cord into the power outlet. If the power outlet has a switch, make sure that it is switched on.
Attempting to turn the projector on again during the cooling process.	Wait until the cooling down process has completed.

## ⑦ No picture.

Cause	Remedy
The video source is not turned on or connected correctly.	Turn the video source on and check that the signal cable is connected correctly.
The projector is not correctly connected to the input signal device.	Check the connection.
The input signal has not been correctly selected.	Select the correct input signal with the <b>SOURCE</b> key on the projector or remote control.

## ⑦ Blurred image.

Cause	Remedy
The projection lens is not correctly focused.	Adjust the focus of the lens using the focus ring.
The projector and the screen are not aligned properly.	Adjust the projection angle and direction as well as the height of the unit if necessary.
The lens cover is still closed.	Open the lens cover.

## ⑦ Remote control does not work.

Cause	Remedy
The battery is out of power.	Replace the battery with new one.
There is an obstacle between the remote control and the projector.	Remove the obstacle.
You are too far away from the projector.	Stand within 7 meters (23 feet) of the projector.

## ⑦ The password is incorrect.

Cause	Remedy
You do not remember the password.	Please see " <a href="#">Entering the password recall procedure</a> " on page 28 for details.

# Specifications

## Projector specifications

 All specifications are subject to change without notice.

### Optical

Resolution  
1024 x 768  
Display system  
Single-chip DLP™ system  
Lens F/Number  
STANDARD LS2SD  
F=2.46 to 2.56, f=22.8 to 28.5mm  
WIDE FIX LS2ST3  
F=2.5, f=11.5mm  
WIDE ZOOM LS2ST1  
F=2.5 to 3.1, f=28.5 to 42.75mm  
SEMI LONG LS2LT1  
F=2.05 to 2.27, f=16.64 to 19.5mm  
LONG ZOOM1 LS2LT2  
F=2.2 to 2.5, f=44.5 to 74.19mm

Lamp  
365W lamp

### Electrical

Power supply  
AC100-240V  
50-60 Hz (Automatic)  
5A  
Power consumption  
480W (Max); < 0.5W (Standby)

### Mechanical

Weight  
18.7 lbs (8.5 Kg)

### Output terminals

Audio signal output  
PC audio jack x 1  
Monitor Out  
D-Sub 15-pin (female) x1  
USB  
TYPE-A (5V/1.5A)  
3D SYNC OUT x 1

### Control

USB  
Type-B x1  
RS-232 serial control  
9 pin x 1  
IR receiver x 2  
12V TRIGGER  
12VDC (Max. 0.2 A) x 1  
LAN control  
RJ45 x 1  
Wired Remote  
PC audio jack x 1

### Input terminals

Computer input  
RGB input  
D-Sub 15-pin (female) x 2  
BNC x 5  
Digital input  
DVI-D x 1  
DISPLAY PORT x 1  
Video signal input  
COMPONENT  
RCA jack X 3  
S-VIDEO  
Mini DIN 4-pin port x 1  
VIDEO  
RCA jack x 1  
SD/HDTV signal input  
Digital - HDMI x 1  
Audio signal input  
Audio in  
PC audio jack x 2  
RCA audio jack (L/R) x 2  
3D SYNC IN  
BNC x 1

### Environmental Requirements

Operating temperature  
0°C–40°C at sea level  
Operating relative humidity  
10%–90% (without condensation)  
Operating altitude  
0–1499 m at 0°C–35°C  
1500–3000 m at 0°C–30°C (with High  
Altitude Mode on)  
Storage temperature  
-20°C–60°C  
Storage humidity  
10%–90% RH (without condensation)  
30°C@0–12,200m above sea level

# Dimensions

431.0 mm (W) x 167.0 mm (H) x 320.5 mm (D)

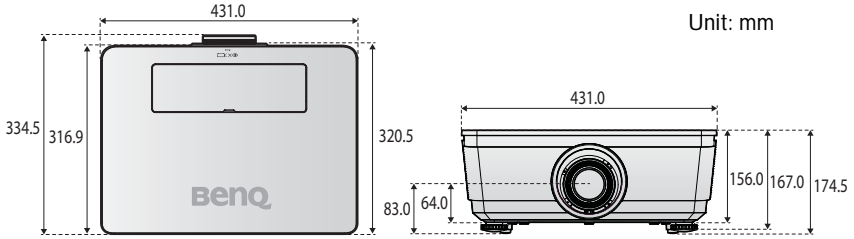

## Ceiling Mount Installation

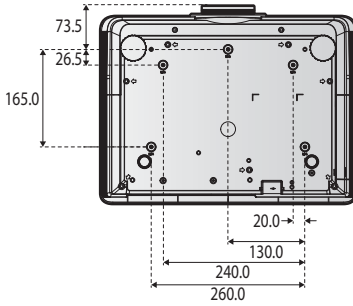

\*Ceiling Mount Screws:  
M4 (Max. L=12, Min. L=10)  
Ceiling mount type: CM00G4

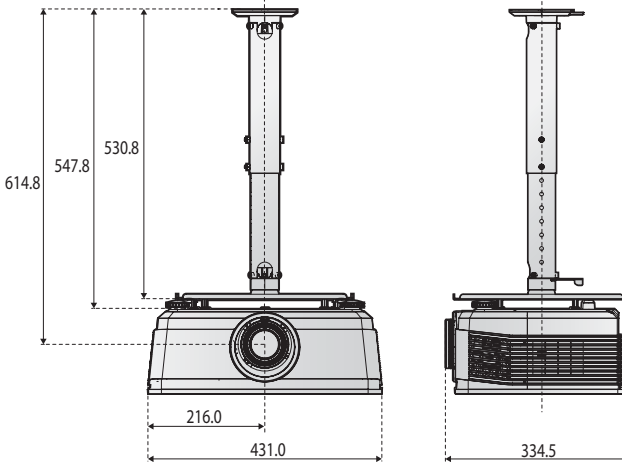

# Timing chart

## Supported timing for PC input

Resolution	Mode	Refresh rate (Hz)	H-frequency (kHz)	Clock (MHz)	3D Field Sequential	3D over-under	3D side-by-side
720 x 400	720 x 400_70	70.087	31.469	28.3221			
640 x 480	VGA_60	59.940	31.469	25.175	⊙	⊙	⊙
	VGA_72	72.809	37.861	31.500			
	VGA_75	75.000	37.500	31.500			
	VGA_85	85.008	43.269	36.000			
800 x 600	SVGA_60	60.317	37.879	40.000	⊙	⊙	⊙
	SVGA_72	72.188	48.077	50.000			
	SVGA_75	75.000	46.875	49.500			
	SVGA_85	85.061	53.674	56.250			
	SVGA_120 (Reduce Blanking)	119.854	77.425	83.000	⊙		
1024 x 768	XGA_60	60.004	48.363	65.000	⊙	⊙	⊙
	XGA_70	70.069	56.476	75.000			
	XGA_75	75.029	60.023	78.750			
	XGA_85	84.997	68.667	94.500			
	XGA_120 (Reduce Blanking)	119.989	97.551	115.500	⊙		
1152 x 864	1152 x 864_75	75.00	67.500	108.000			
1024 x 576	BenQ NB Timing	60.00	35.820	46.996			
1024 x 600	BenQ NB Timing	64.995	41.467	51.419			
1280 x 720	1280 x 720_60	60	45.000	74.250	⊙	⊙	⊙
1280 x 768	1280 x 768_60	59.870	47.776	79.5	⊙	⊙	⊙
1280 x 800	WXGA_60	59.810	49.702	83.500	⊙	⊙	⊙
	WXGA_75	74.934	62.795	106.500			
	WXGA_85	84.880	71.554	122.500			
	WXGA_120 (Reduce Blanking)	119.909	101.563	146.25	⊙		
1280 x 1024	SXGA_60	60.020	63.981	108.000		⊙	⊙
	SXGA_75	75.025	79.976	135.000			
	SXGA_85	85.024	91.146	157.500			

Resolution	Mode	Refresh rate (Hz)	H-frequency (kHz)	Clock (MHz)	3D Field Sequential	3D over-under	3D side-by-side
1280 x 960	1280 x 960_60	60.000	60.000	108		⊙	⊙
	1280 x 960_85	85.002	85.938	148.500			
1360 x 768	1360 x 768_60	60.015	47.712	85.500		⊙	⊙
1440 x 900	WXGA+_60	59.887	55.935	106.500		⊙	⊙
1400 x 1050	SXGA+_60	59.978	65.317	121.750		⊙	⊙
1600 x 1200	UXGA	60.000	75.000	162.000		⊙	⊙
1680 x 1050	1680 x 1050_60	59.954	65.290	146.250		⊙	⊙
1920 x 1080 @60Hz	1920 x 1080_60 (Reduce Blanking)	60.000	67.500	148.500			
1920 x 1200	1920 x 1200_60 (Reduce Blanking)	59.950	74.038	154.000		⊙	⊙
640 x 480 @67Hz	MAC13	66.667	35.000	30.240			
832 x 624 @75Hz	MAC16	74.546	49.722	57.280			
1024 x 768 @75Hz	MAC19	74.93	60.241	80.000			
1152 x 870 @75Hz	MAC21	75.06	68.68	100.00			

☞ There 3D timing showing depend the EDID file and VGA display card. It is possible that user cannot choose the above 3D timings on VGA display card.



## Support timing for Component - YPbPr input

Timing	Resolution	Horizontal frequency (KHz)	Vertical Frequency (Hz)	Dot Clock Frequency (MHz)	3D Field Sequential
480i	720 x 480	15.73	59.94	13.5	⊙
480p	720 x 480	31.47	59.94	27	⊙
576i	720 x 576	15.63	50	13.5	
576p	720 x 576	31.25	50	27	
720/50p	1280 x 720	37.5	50	74.25	
720/60p	1280 x 720	45.00	60	74.25	⊙
1080/50i	1920 x 1080	28.13	50	74.25	
1080/60i	1920 x 1080	33.75	60	74.25	
1080/24p	1920 x 1080	27	24	74.25	
1080/25p	1920 x 1080	28.13	25	74.25	
1080/30p	1920 x 1080	33.75	30	74.25	
1080/50p	1920 x 1080	56.25	50	148.5	
1080/60p	1920 x 1080	67.5	60	148.5	

## Support timing for Video and S-Video input

Video mode	Horizontal frequency (KHz)	Vertical Frequency (Hz)	Sub-carrier Frequency (MHz)	3D Field Sequential
NTSC	15.73	60	3.58	◎
PAL	15.63	50	4.43	
SECAM	15.63	50	4.25 or 4.41	
PAL-M	15.73	60	3.58	
PAL-N	15.63	50	3.58	
PAL-60	15.73	60	4.43	
NTSC4.43	15.73	60	4.43	

## Support timing for HDMI (HDCP)/DVI-D input

Resolution	Mode	Refresh rate (Hz)	H-frequency (kHz)	Clock (MHz)	3D Field Sequential	3D over-under	3D side-by-side
640 x 480	VGA_60	59.940	31.469	25.175	◎	◎	◎
	VGA_72	72.809	37.861	31.500			
	VGA_75	75.000	37.500	31.500			
	VGA_85	85.008	43.269	36.000			
720 x 400	720 x 400_70	70.087	31.469	28.3221			
800 x 600	SVGA_60	60.317	37.879	40.000	◎	◎	◎
	SVGA_72	72.188	48.077	50.000			
	SVGA_75	75.000	46.875	49.500			
	SVGA_85	85.061	53.674	56.250			
	SVGA_120 (Reduce Blanking)	119.854	77.425	83.000	◎		
1024 x 768	XGA_60	60.004	48.363	65.000	◎	◎	◎
	XGA_70	70.069	56.476	75.000			
	XGA_75	75.029	60.023	78.750			
	XGA_85	84.997	68.667	94.500			
	XGA_120 (Reduce Blanking)	119.989	97.551	115.500	◎		
1152 x 864	1152 x 864_75	75.00	67.500	108.000			
1024 x 576	BenQ Notebook Timing	60.00	35.820	46.996			
1024 x 600	BenQ Notebook Timing	64.995	41.467	51.419			
1280 x 720	1280 x 720_60	60	45.000	74.250	◎	◎	◎

Resolution	Mode	Refresh rate (Hz)	H-frequency (kHz)	Clock (MHz)	3D Field Sequential	3D over-under	3D side-by-side
1280 x 768	1280 x 768_60	59.870	47.776	79.5	⊙	⊙	⊙
1280 x 800	WXGA_60	59.810	49.702	83.500	⊙	⊙	⊙
	WXGA_75	74.934	62.795	106.500			
	WXGA_85	84.880	71.554	122.500			
	WXGA_120 (Reduce Blanking)	119.909	101.563	146.25	⊙		
1280 x 1024	SXGA_60	60.020	63.981	108.000		⊙	⊙
	SXGA_75	75.025	79.976	135.000			
	SXGA_85	85.024	91.146	157.500			
1280 x 960	1280 x 960_60	60.000	60.000	108		⊙	⊙
	1280 x 960_85	85.002	85.938	148.500			
1360 x 768	1360 x 768_60	60.015	47.712	85.500		⊙	⊙
1440 x 900	WXGA+_60	59.887	55.935	106.500		⊙	⊙
1400 x 1050	SXGA+_60	59.978	65.317	121.750		⊙	⊙
1600 x 1200	UXGA	60.000	75.000	162.000		⊙	
1680 x 1050	1680 x 1050_60	59.954	65.290	146.250		⊙	⊙
1920 x 1080 @60Hz	1920 x 1080_60 (Reduce Blanking)	60.000	67.500	148.500		⊙	⊙
1920 x 1200	1920 x 1200_60 (Reduce Blanking)	59.950	74.038	154.000		⊙	⊙
640 x 480 @67Hz	MAC13	66.667	35.000	30.240			
832 x 624 @75Hz	MAC16	74.546	49.722	57.280			
1024 x 768 @75Hz	MAC19	75.020	60.241	80.000			
1152 x 870 @75Hz	MAC21	75.06	68.68	100.00			

☞ There timing showing depend the EDID file and VGA graphic card limitation. It is possible that user cannot choose the above timings on VGA display card.

## Supporting timing for HDMI Video input

Timing	Resolution	Horizontal frequency (KHz)	Vertical frequency (Hz)	Dot Clock Frequency (MHz)	3D Field Sequential	3D frame packing	3D over-under	3D side-by-side
480i	720 (1440) x 480	15.73	59.94	27	⊙			
480p	720 x 480	31.47	59.94	27	⊙			
576i	720 (1440) x 576	15.63	50	27				
576p	720 x 576	31.25	50	27				
720/50p	1280 x 720	37.5	50	74.25		⊙	⊙	⊙
720/60p	1280 x 720	45.00	60	74.25	⊙	⊙	⊙	⊙
1080/24p	1920 x 1080	27	24	74.25		⊙	⊙	⊙
1080/25p	1920 x 1080	28.13	25	74.25				
1080/30p	1920 x 1080	33.75	30	74.25				
1080/50i	1920 x 1080	28.13	50	74.25				⊙
1080/60i	1920 x 1080	33.75	60	74.25				⊙
1080/50p	1920 x 1080	56.25	50	148.5			⊙	⊙
1080/60p	1920 x 1080	67.5	60	148.5			⊙	⊙

# RS232 command control

Function	Type	Operation	ASCII
Power	Write	Power On	<CR>*pow=on#<CR>
	Write	Power off	<CR>*pow=off#<CR>
	Read	Power Status	<CR>*pow=?#<CR>
Source Selection	Write	COMPUTER/YPbPr	<CR>*sour=RGB#<CR>
	Write	COMPUTER 2/YPbPr2	<CR>*sour=RGB2#<CR>
	Write	COMPUTER 3/YPbPr3	<CR>*sour=RGB3#<CR>
	Write	Component	<CR>*sour=ypr#<CR>
	Write	DVI-D	<CR>*sour=dvid#<CR>
	Write	HDMI(MHL)	<CR>*sour=hdm#<CR>
	Write	Composite	<CR>*sour=vid#<CR>
	Write	S-Video	<CR>*sour=svid#<CR>
	Write	DP	<CR>*sour=dp#<CR>
Read	Current source	<CR>*sour=?#<CR>	
Audio Control	Write	Mute On	<CR>*mute=on#<CR>
	Write	Mute Off	<CR>*mute=off#<CR>
	Read	Mute Status	<CR>*mute=?#<CR>
	Write	Volume +	<CR>*vol=+#<CR>
	Write	Volume -	<CR>*vol=#<CR>
	Write	Volume level for customer	<CR>*vol=value#<CR>
	Read	Volume Status	<CR>*vol=?#<CR>
Audio source select	Write	Audio pass Through off	<CR>*audiosour=off#<CR>
	Write	Audio-Computer1	<CR>*audiosour=RGB#<CR>
	Write	Audio-Computer2	<CR>*audiosour=RGB2#<CR>
	Write	Audio-Video/S-Video	<CR>*audiosour=vid#<CR>
	Write	Audio-Component	<CR>*audiosour=ypr#<CR>
	Write	Audio-HDMI	<CR>*audiosour=hdm#<CR>
	Read	Audio pass Status	<CR>*audiosour=?#<CR>
Picture Setting	Write	Presentation	<CR>*appmod=preset#<CR>
	Write	sRGB	<CR>*appmod=srgb#<CR>
	Write	Bright	<CR>*appmod=bright#<CR>
	Write	Standard/Vivid	<CR>*appmod=std#<CR>
	Write	User1	<CR>*appmod=user1#<CR>
	Write	User2	<CR>*appmod=user2#<CR>
	Write	3D	<CR>*appmod=three#<CR>

Function	Type	Operation	ASCII
Picture Setting	Write	Contrast +	<CR>*con=+#<CR>
	Write	Contrast -	<CR>*con=-#<CR>
	Read	Contrast value	<CR>*con=?#<CR>
	Write	Brightness +	<CR>*bri=+#<CR>
	Write	Brightness -	<CR>*bri=-#<CR>
	Read	Brightness value	<CR>*bri=?#<CR>
	Write	Color +	<CR>*color=+#<CR>
	Write	Color -	<CR>*color=-#<CR>
	Read	Color value	<CR>*color=?#<CR>
	Write	Sharpness +	<CR>*sharp=+#<CR>
	Write	Sharpness -	<CR>*sharp=-#<CR>
	Read	Sharpness value	<CR>*sharp=?#<CR>
	Write	Color Temperature-Warm	<CR>*ct=warm#<CR>
	Write	Color Temperature-Normal	<CR>*ct=normal#<CR>
	Write	Color Temperature-Cool	<CR>*ct=cool#<CR>
	Read	Color Temperature Status	<CR>*ct=?#<CR>
	Write	Aspect 4:3	<CR>*asp=4:3#<CR>
	Write	Aspect 16:9	<CR>*asp=16:9#<CR>
	Write	Aspect 16:10	<CR>*asp=16:10#<CR>
	Write	Aspect Auto	<CR>*asp=AUTO#<CR>
	Write	Aspect Real	<CR>*asp=REAL#<CR>
	Read	Aspect Status	<CR>*asp=?#<CR>
	Write	Digital Zoom In	<CR>*zoomI#<CR>
	Write	Digital Zoom out	<CR>*zoomO#<CR>
Write	Auto	<CR>*auto#<CR>	
Write	Brilliant color on	<CR>*BC=on#<CR>	
Write	Brilliant color off	<CR>*BC=off#<CR>	
Read	Brilliant color status	<CR>*BC=?#<CR>	
Operation Settings	Write	Projector Position-Front Table	<CR>*pp=FT#<CR>
	Write	Projector Position-Rear Table	<CR>*pp=RE#<CR>
	Write	Projector Position-Rear Ceiling	<CR>*pp=RC#<CR>
	Write	Projector Position-Front Ceiling	<CR>*pp=FC#<CR>
	Read	Projector Position Status	<CR>*pp=?#<CR>
	Write	Quick cooling on	<CR>*qcool=on<CR>
	Write	Quick cooling off	<CR>*qcool=off<CR>
	Read	Quick cooling status	<CR>*qcool=?<CR>
	Write	Quick auto search	<CR>*QAS=on#<CR>
	Write	Quick auto search	<CR>*QAS=off#<CR>
	Read	Quick auto search status	<CR>*QAS=?#<CR>
	Write	Direct Power On-on	<CR>*directpower=on#<CR>
	Write	Direct Power On-off	<CR>*directpower=off#<CR>
	Read	Direct Power On-Status	<CR>*directpower=?#<CR>
	Write	Signal Power On-on	<CR>*autopower=on#<CR>
	Write	Signal Power On-off	<CR>*autopower=off#<CR>
	Read	Signal Power On-Status	<CR>*autopower=?#<CR>
	Write	Standby Settings-Network on	<CR>*standbynet=on#<CR>
	Write	Standby Settings-Network off	<CR>*standbynet=off#<CR>
	Read	Standby Settings-Network Status	<CR>*standbynet=?#<CR>
	Write	Standby Settings-Monitor Out on	<CR>*standbymnt=on#<CR>
	Write	Standby Settings-Monitor Out off	<CR>*standbymnt=off#<CR>
	Read	Standby Settings-Monitor Out Status	<CR>*standbymnt=?#<CR>

Function	Type	Operation	ASCII	
Baud Rate	Write	2400	<CR>*baud=2400#<CR>	
	Write	4800	<CR>*baud=4800#<CR>	
	Write	9600	<CR>*baud=9600#<CR>	
	Write	14400	<CR>*baud=14400#<CR>	
	Write	19200	<CR>*baud=19200#<CR>	
	Write	38400	<CR>*baud=38400#<CR>	
	Write	57600	<CR>*baud=57600#<CR>	
	Write	115200	<CR>*baud=115200#<CR>	
Lamp Control	Read	Current Baud Rate	<CR>*baud=?#<CR>	
	Read	Lamp Hour	<CR>*ltime=?#<CR>	
	Write	Normal mode	<CR>*lampm=lnor#<CR>	
	Write	Eco mode	<CR>*lampm=eco#<CR>	
Miscellaneous	Read	Lamp Mode Status	<CR>*lampm=?#<CR>	
	Read	Model Name	<CR>*modelname=?#<CR>	
	Write	Blank On	<CR>*blank=on#<CR>	
	Write	Blank Off	<CR>*blank=off#<CR>	
	Read	Blank Status	<CR>*blank=?#<CR>	
	Write	Freeze On	<CR>*freeze=on#<CR>	
	Write	Freeze Off	<CR>*freeze=off#<CR>	
	Read	Freeze Status	<CR>*freeze=?#<CR>	
	Write	Menu On	<CR>*menu=on#<CR>	
	Write	Menu Off	<CR>*menu=off#<CR>	
	Write	Up	<CR>*up#<CR>	
	Write	Down	<CR>*down#<CR>	
	Write	Right	<CR>*right#<CR>	
	Write	Left	<CR>*left#<CR>	
	Write	Enter	<CR>*enter#<CR>	
	Write	3D Sync Off	<CR>*3d=off#<CR>	
	Write	3D Auto	<CR>*3d=auto#<CR>	
	Write	3D Sync Top Bottom	<CR>*3d=tb#<CR>	
	Write	3D Sync Frame Sequential	<CR>*3d=fs#<CR>	
	Write	3D Frame packing	<CR>*3d=fp#<CR>	
	Write	3D Side by side	<CR>*3d=sbs#<CR>	
	Write	3D inverter disable	<CR>*3d=da#<CR>	
	Write	3D inverter	<CR>*3d=lv#<CR>	
	Write	3D nVIDIA	<CR>*3d=nvidia#<CR>	
	Read	3D Sync Status	<CR>*3d=?#<CR>	
	Write	Remote Receiver-front+rear	<CR>*rr=fr#<CR>	
	Write	Remote Receiver-front	<CR>*rr=f#<CR>	
	Write	Remote Receiver-rear	<CR>*rr=r#<CR>	
	Read	Remote Receiver Status	<CR>*rr=?#<CR>	
	Write	AMX Device Discovery-on	<CR>*amxdd=on#<CR>	
	Write	AMX Device Discovery-off	<CR>*amxdd=off#<CR>	
	Read	AMX Device Discovery Status	<CR>*amxdd=?#<CR>	
	Read	Mac Address	<CR>*macaddr=?#<CR>	
	Write	High Altitude mode on	<CR>*Highaltitude=on#<CR>	
	Write	High Altitude mode off	<CR>*Highaltitude=off#<CR>	
	Read	High Altitude mode status	<CR>*Highaltitude=?#<CR>	
	Service	Write	Error code system enable	<CR>*error=enable#<CR>
		Read	Error Code report	<CR>*error=report#<CR>

# Warranty and Copyright information

## Limited warranty

BenQ warrants this product against any defects in material and workmanship, under normal usage and storage.

Proof of purchase date will be required with any warranty claim. In the event this product is found to be defective within the warranty period, BenQ's only obligation and your exclusive remedy shall be replacement of any defective parts (labor included). To obtain warranty service, immediately notify the dealer from which you purchased the product of any defects.

Important: The above warranty shall be void if the customer fails to operate the product in accordance with BenQ's written instructions, especially the ambient humidity must be in-between 10% and 90%, temperature in-between 0°C and 35°C, altitude lower than 4920 feet, and avoiding to operate the projector in a dusty environment. This warranty gives you specific legal rights, and you may have other rights which vary from country to country.

For other information, please visit [www.BenQ.com](http://www.BenQ.com).

## Copyright

Copyright 2011 by BenQ Corporation. All rights reserved. No part of this publication may be reproduced, transmitted, transcribed, stored in a retrieval system or translated into any language or computer language, in any form or by any means, electronic, mechanical, magnetic, optical, chemical, manual or otherwise, without the prior written permission of BenQ Corporation.

## Disclaimer

BenQ Corporation makes no representations or warranties, either expressed or implied, with respect to the contents hereof and specifically disclaims any warranties, merchantability or fitness for any particular purpose. Further, BenQ Corporation reserves the right to revise this publication and to make changes from time to time in the contents hereof without obligation to notify any person of such revision or changes.

\*DLP, Digital Micromirror Device and DMD are trademarks of Texas Instruments. Others are copyrights of their respective companies or organizations.

## Patents

Please go to <http://patmarking.benq.com/> for the details of the BenQ projector patent.