

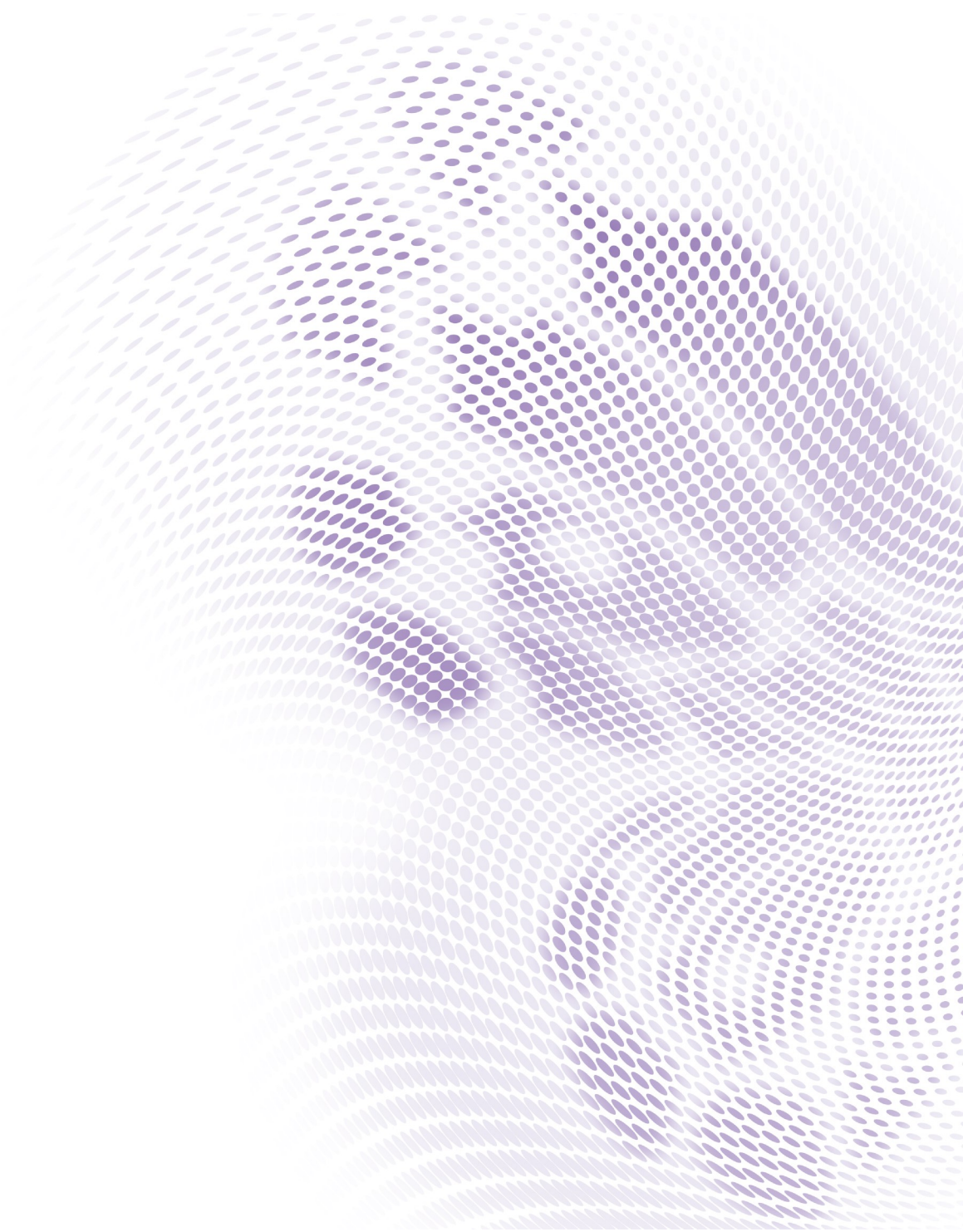

TK850

Projector RS232 Command Control

Installation Guide



# Table of Contents

Introduction .....	3
Wire arrangement.....	3
RS232 pin assignment.....	3
Connections and communication settings.....	4
RS232 serial port with a crossover cable .....	4
Settings .....	4
RS232 via LAN.....	6
Settings .....	6
RS232 via HDBaseT.....	6
Settings .....	6
Command table.....	8

# Introduction

The document describes how to control your BenQ projector via RS232 from a computer. Follow the procedures to complete the connection and settings first, and refer to the command table for RS232 commands.



Available functions and commands vary by model. Check the specifications and user manual of the purchased projector for product functions.

## Wire arrangement

Wire Arrangement		
P1	Color	P2
1	Black	1
2	Brown	3
3	Red	2
4	Orange	4
5	Yellow	5
6	Green	6
7	Blue	7
8	Purple	8
9	Gray	9
Case	Drain wire	Case

## RS232 pin assignment



Pin	Description	Pin	Description
1	NC	2	RXD
3	TXD	4	NC
5	GND	6	NC
7	RTS	8	CTS
9	NC		

# Connections and communication settings

Choose one of the connections and set up properly before RS232 control.

## RS232 serial port with a crossover cable

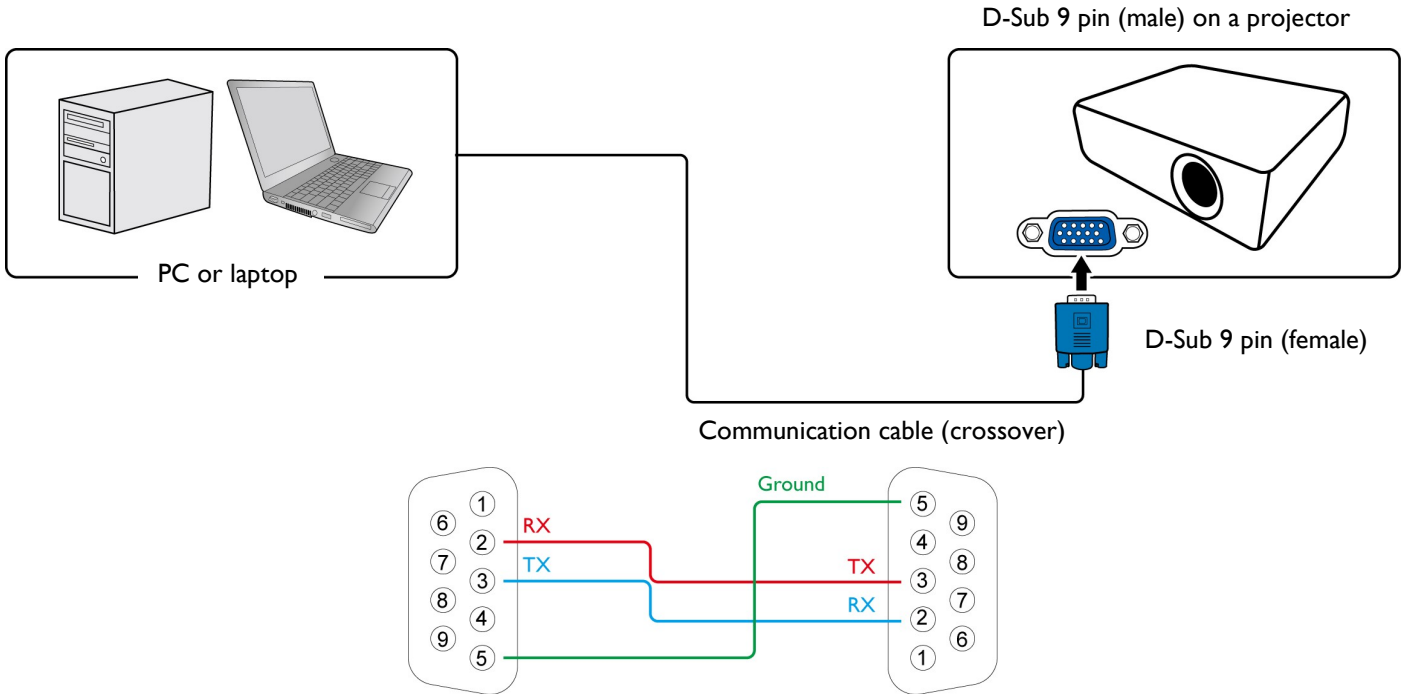

## Settings

 On-screen images in this document are for reference only. The screens may vary depending on your Operating System, I/O ports used for connection, and the specifications of the connected projector.

- I. Determine the COM Port name used for the RS232 communications in **Device Manager**.

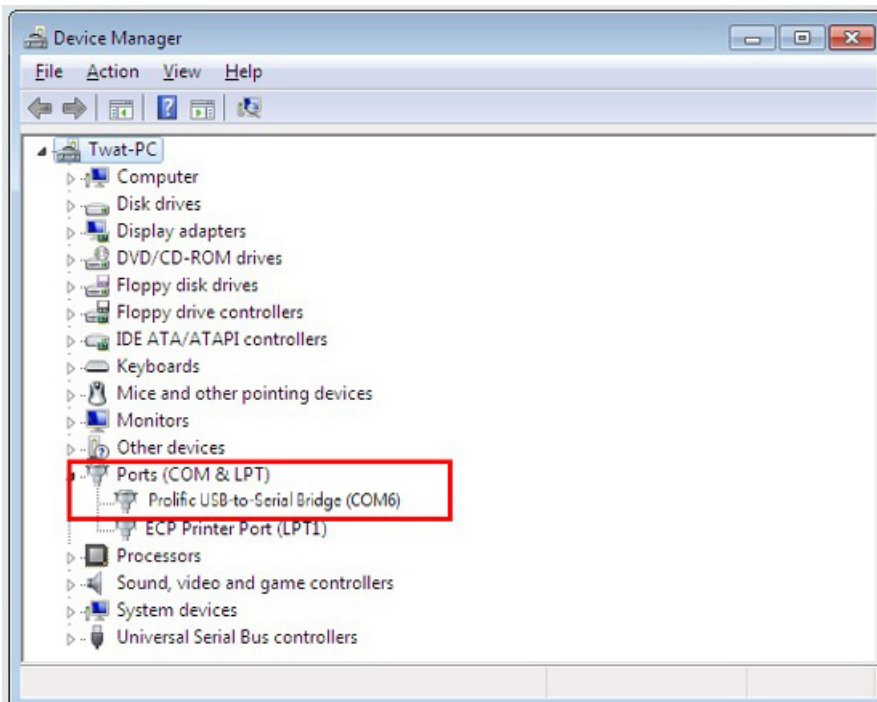

2. Choose **Serial** and the corresponding COM port as the communication port. In this given example, COM6 is selected.



3. Finish **Serial** port setup.

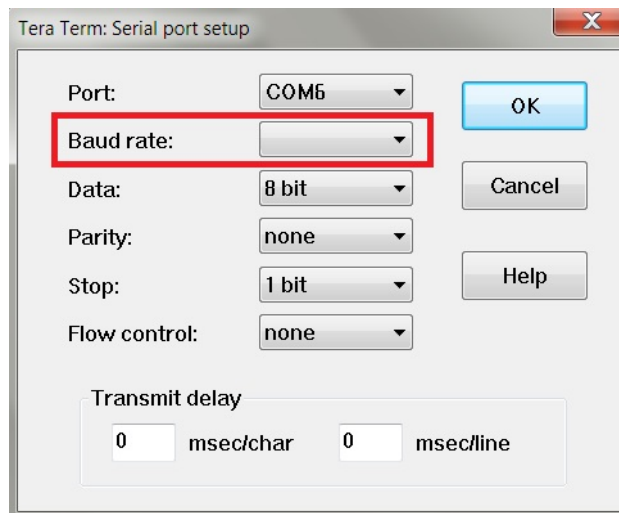

Baud rate	9600 / 14400 / 19200 / 38400 / 57600 / 115200 bps  Check the baud rate of the connected projector from its OSD menu.
Data length	8 bit
Parity check	None
Stop bit	1 bit
Flow control	None

## RS232 via LAN

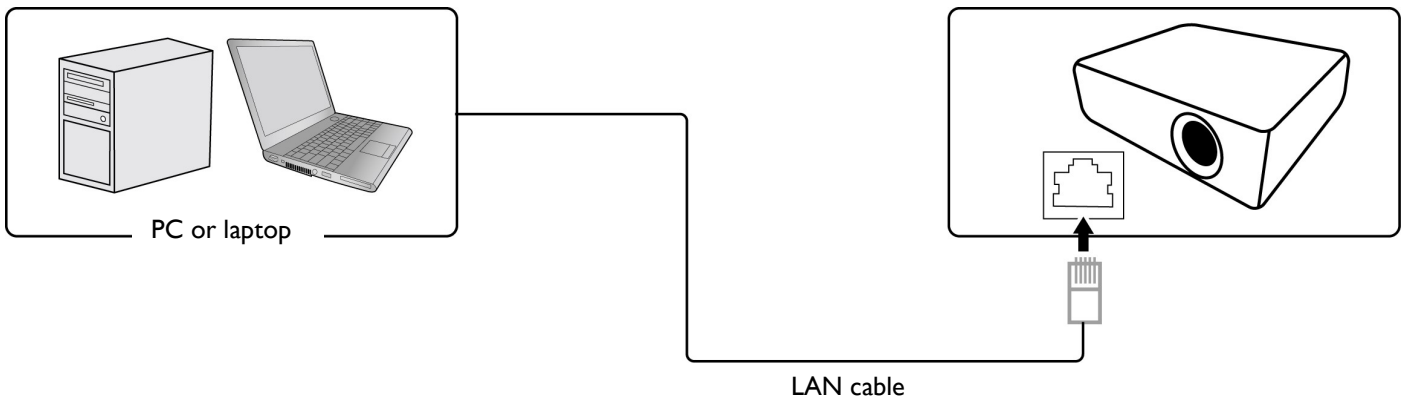

## Settings

1. Find the Wired LAN IP address of the connected projector from the OSD menu and make sure the projector and the computer are within the same network.
2. Input **8000** in the **TCP port #** field.

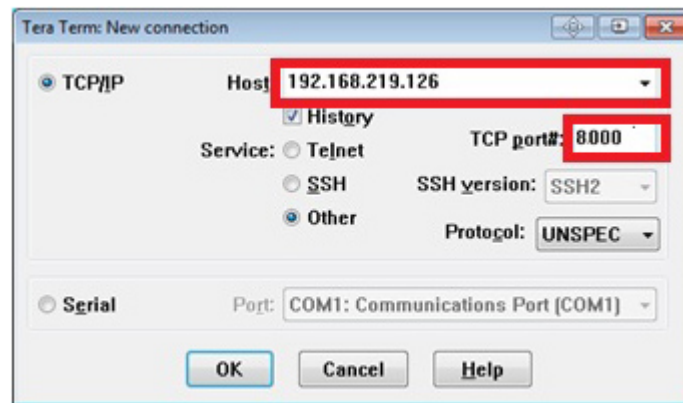

## RS232 via HDBaseT

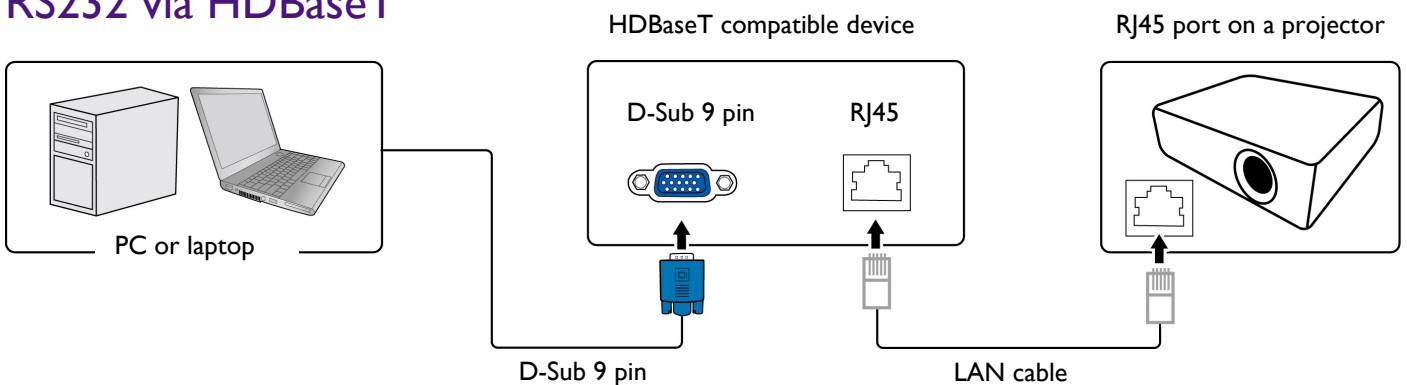



## Settings

1. Determine the COM Port name used for the RS232 communications in **Device Manager**.
2. Choose **Serial** and the corresponding COM port as the communication port. In this given example, COM6 is selected.

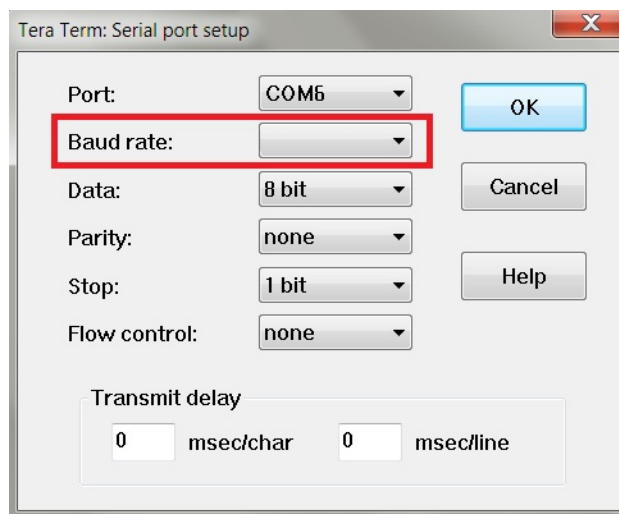

3. Finish **Serial** port setup.



Baud rate	9600 / 14400 / 19200 / 38400 / 57600 / 115200 bps  Check the baud rate of the connected projector from its OSD menu.
Data length	8 bit
Parity check	None
Stop bit	1 bit
Flow control	None

# Command table



- Available features differ by projector specification, input sources, settings, etc..
- Commands are working if the standby power is 0.5W or a supported baud rate of the projector is set.
- Uppercase, lowercase, and a mixture of both types of characters are accepted for a command.
- If a command format is illegal, it will echo **Illegal format**.
- If a command with correct format is not valid for the projector model, it will echo **Unsupported item**.
- If a command with correct format cannot be executed under certain condition, it will echo **Block item**.
- If RS232 control is performed via LAN, a command works whether it starts and ends with **<CR>**. All the commands and behaviors are identical with the control through a serial port.

Function	Type	Operation	ASCII	Support
Power	Write	Power On	<CR>*pow=on#<CR>	YES
	Write	Power off	<CR>*pow=off#<CR>	YES
	Read	Power Status	<CR>*pow=?#<CR>	YES
Source Selection	Write	COMPUTER/YPbPr	<CR>*sour=RGB#<CR>	NO
	Write	COMPUTER 2/YPbPr2	<CR>*sour=RGB2#<CR>	NO
	Write	COMPUTER 3/YPbPr3	<CR>*sour=RGB3#<CR>	NO
	Write	Component	<CR>*sour=ypbr#<CR>	NO
	Write	Component2	<CR>*sour=ypbr2#<CR>	NO
	Write	DVI-A	<CR>*sour=dviA#<CR>	NO
	Write	DVI-D	<CR>*sour=dvid#<CR>	NO
	Write	HDMI(MHL)	<CR>*sour=hdmi#<CR>	YES
	Write	HDMI 2(MHL2)	<CR>*sour=hdmi2#<CR>	YES
	Write	Composite	<CR>*sour=vid#<CR>	NO
	Write	S-Video	<CR>*sour=svid#<CR>	NO
	Write	Network	<CR>*sour=network#<CR>	NO
	Write	USB Display	<CR>*sour=usbdisplay#<CR>	NO
	Write	USB Reader	<CR>*sour=usbreader#<CR>	YES
	Write	HDbaseT	<CR>*sour=hdbaset#<CR>	NO
	Write	DisplayPort	<CR>*sour=dp#<CR>	NO
	Write	3G-SDI	<CR>*sour=sdi#<CR>	NO
Read	Current source	<CR>*sour=?#<CR>	YES	
Audio Control	Write	Mute On	<CR>*mute=on#<CR>	YES
	Write	Mute Off	<CR>*mute=off#<CR>	YES



	Read	Mute Status	<CR>*mute=?#<CR>	YES
	Write	Volume +	<CR>*vol=+#<CR>	YES
	Write	Volume -	<CR>*vol=-#<CR>	YES
	Write	Volume level for customer	<CR>*vol=value#<CR>	YES
	Read	Volume Status	<CR>*vol=?#<CR>	YES
	Write	Mic.Volume +	<CR>*micvol=+#<CR>	NO
	Write	Mic.Volume -	<CR>*micvol=-#<CR>	NO
	Read	Mic.Volume Status	<CR>*micvol=?#<CR>	NO
Audio source select	Write	Audio pass Through off	<CR>*audiosour=off#<CR>	NO
	Write	Audio-Computer 1	<CR>*audiosour=RGB#<CR>	NO
	Write	Audio-Computer2	<CR>*audiosour=RGB2#<CR>	NO
	Write	Audio-Video/S-Video	<CR>*audiosour=vid#<CR>	NO
	Write	Audio-Component	<CR>*audiosour=ypbr#<CR>	NO
	Write	Audio-HDMI	<CR>*audiosour=hdmi#<CR>	NO
	Write	Audio-HDMI2	<CR>*audiosour=hdmi2#<CR>	NO
	Read	Audio pass Status	<CR>*audiosour=?#<CR>	NO
Picture	Write	Bright	<CR>*appmod=bright#<CR>	YES
	Read	Silence mode	<CR>*appmod=silence#<CR>	YES
	Write	Vivid	<CR>*appmod=vivid#<CR>	NO
	Write	User 1	<CR>*appmod=user 1#<CR>	YES
	Read	ISF Day	<CR>*appmod=isfday#<CR>	NO
	Read	ISF Night	<CR>*appmod=isfnight#<CR>	NO
	Read	3D	<CR>*appmod=threed#<CR>	Yes
	Write	Cinema	<CR>*appmod=cine#<CR>	YES
	Write	Sport	<CR>*appmod=sport#<CR>	YES
	Write	Living Room	<CR>*appmod=livingroom#<CR>	Yes
	Read	HDR 10	<CR>*appmod=hdr 10<CR>	YES
	Read	HLG	<CR>*appmod=hlg<CR>	YES
	Write	Picture Mode	<CR>*appmod=?#<CR>	YES
Picture Setting	Write	Contrast +	<CR>*con=+#<CR>	YES
	Write	Contrast -	<CR>*con=-#<CR>	YES

Write	Set Contrast value	<CR>*con=value#<CR>	YES
Read	Contrast value	<CR>*con=?#<CR>	YES
Write	Brightness +	<CR>*bri=+#<CR>	YES
Write	Brightness -	<CR>*bri=-#<CR>	YES
Write	Set Brightness value	<CR>*bri=value#<CR>	YES
Read	Brightness value	<CR>*bri=?#<CR>	YES
Write	Color +	<CR>*color=+#<CR>	YES
Write	Color -	<CR>*color=-#<CR>	YES
Write	Set Color value	<CR>*color=value#<CR>	YES
Read	Color value	<CR>*color=?#<CR>	YES
Write	Tint +	<CR>*tint=+#<CR>	YES
Write	Tint -	<CR>*tint=-#<CR>	YES
Write	Set Tint value	<CR>*tint=value#<CR>	YES
Read	Get Tint value	<CR>*tint=?#<CR>	YES
Write	Sharpness +	<CR>*sharp=+#<CR>	YES
Write	Sharpness -	<CR>*sharp=-#<CR>	YES
Write	Set Sharpness value	<CR>*sharp=value#<CR>	YES
Read	Sharpness value	<CR>*sharp=?#<CR>	YES
Write	Flesh Tone +	<CR>*fleshtone=+#<CR>	NO
Write	Flesh Tone -	<CR>*fleshtone=-#<CR>	NO
Read	Flesh Tone value	<CR>*fleshtone=?#<CR>	NO
Write	Color Temperature-Warmer	<CR>*ct=warmer#<CR>	NO
Write	Color Temperature-Warm	<CR>*ct=warm#<CR>	YES
Write	Color Temperature-Normal	<CR>*ct=normal#<CR>	YES
Write	Color Temperature-Cool	<CR>*ct=cool#<CR>	YES
Write	Color Temperature-Cooler	<CR>*ct=cooler#<CR>	NO
Write	Color Temperature-lamp native	<CR>*ct=ative#<CR>	YES
Read	Color Temperature Status	<CR>*ct=?#<CR>	YES
Write	Aspect 4:3	<CR>*asp=4:3#<CR>	YES

	Write	Aspect 16:6	<CR>*asp=16:6#<CR>	NO
	Write	Aspect 16:9	<CR>*asp=16:9#<CR>	YES
	Write	Aspect 16:10	<CR>*asp=16:10#<CR>	NO
	Write	Aspect Auto	<CR>*asp=AUTO#<CR>	YES
	Write	Aspect Real	<CR>*asp=REAL#<CR>	YES
	Write	Aspect Letterbox	<CR>*asp=LBOX#<CR>	NO
	Write	Aspect Wide	<CR>*asp=WIDE#<CR>	NO
	Write	Aspect Anamorphic	<CR>*asp=ANAM#<CR>	NO
	Write	Aspect Anamorphic 2.35	<CR>*asp=ANAM2.35#<CR>	NO
	Write	Aspect Anamorphic 16:9	<CR>*asp=ANAM16:9#<CR>	NO
	Read	Aspect Status	<CR>*asp=?#<CR>	YES
	Write	Digital Zoom In	<CR>*zoomI#<CR>	NO
	Write	Digital Zoom out	<CR>*zoomO#<CR>	NO
	Write	Auto	<CR>*auto#<CR>	NO
	Write	Brilliant color on	<CR>*BC=on#<CR>	YES
	Write	Brilliant color off	<CR>*BC=off#<CR>	YES
	Write	Reset current picture settings	<CR>*rstcurpicsetting#<CR>	YES
	Write	Reset all picture settings	<CR>*rstallpicsetting#<CR>	NO
	Read	Brilliant color status	<CR>*BC=?#<CR>	YES
Operation Settings	Write	Projector Position-Front Table	<CR>*pp=FT#<CR>	YES
	Write	Projector Position-Rear Table	<CR>*pp=RE#<CR>	YES
	Write	Projector Position-Rear Ceiling	<CR>*pp=RC#<CR>	YES
	Write	Projector Position-Front Ceiling	<CR>*pp=FC#<CR>	YES
	Write	Quick cooling on	<CR>*qcool=on<CR>	NO
	Write	Quick cooling off	<CR>*qcool=off<CR>	NO
	Read	Quick cooling status	<CR>*qcool=?<CR>	NO
	Write	Quick auto search	<CR>*QAS=on#<CR>	NO
	Write	Quick auto search	<CR>*QAS=off#<CR>	NO

Read	Quick auto search status	<CR>*QAS=?#<CR>	NO	
Read	Projector Position Status	<CR>*pp=?#<CR>	YES	
Write	Direct Power On-on	<CR>*directpower=on#<CR>	YES	
Write	Direct Power On-off	<CR>*directpower=off#<CR>	YES	
Read	Direct Power On-Status	<CR>*directpower=?#<CR>	YES	
Write	Signal Power On-on	<CR>*autopower=on#<CR>	NO	
Write	Signal Power On-off	<CR>*autopower=off#<CR>	NO	
Read	Signal Power On-Status	<CR>*autopower=?#<CR>	NO	
Write	Standby Settings-Network on	<CR>*standbynet=on#<CR>	NO	
Write	Standby Settings-Network off	<CR>*standbynet=off#<CR>	NO	
Read	Standby Settings-Network Status	<CR>*standbynet=?#<CR>	NO	
Write	Standby Settings-Microphone on	<CR>*standbymic=on#<CR>	NO	
Write	Standby Settings-Microphone off	<CR>*standbymic=off#<CR>	NO	
Read	Standby Settings-Microphone Status	<CR>*standbymic=?#<CR>	NO	
Write	Standby Settings-Monitor Out on	<CR>*standbymnt=on#<CR>	NO	
Write	Standby Settings-Monitor Out off	<CR>*standbymnt=off#<CR>	NO	
Read	Standby Settings-Monitor Out Status	<CR>*standbymnt=?#<CR>	NO	
Baud Rate	Write	2400	<CR>*baud=2400#<CR>	NO

	Write	4800	<CR>*baud=4800#<CR>	NO
	Write	9600	<CR>*baud=9600#<CR>	NO
	Write	14400	<CR>*baud=14400#<CR>	NO
	Write	19200	<CR>*baud=19200#<CR>	NO
	Write	38400	<CR>*baud=38400#<CR>	NO
	Write	57600	<CR>*baud=57600#<CR>	NO
	Write	115200	<CR>*baud=115200#<CR>	NO
	Read	Current Baud Rate	<CR>*baud=?#<CR>	NO
Lamp Control	Read	Lamp Hour	<CR>*ltim=?#<CR>	YES
	Read	Lamp2 Hour	<CR>*ltim2=?#<CR>	NO
	Write	Normal mode	<CR>*lampm=lnor#<CR>	YES
	Write	Eco mode	<CR>*lampm=eco#<CR>	YES
	Write	SmartEco mode	<CR>*lampm=seco#<CR>	YES
	Write	SmartEco mode 2	<CR>*lampm=seco2#<CR>	NO
	Write	SmartEco mode 3	<CR>*lampm=seco3#<CR>	NO
	Write	Dimming mode	<CR>*lampm=dimming#<CR>	NO
	Write	Custom mode	<CR>*lampm=custom#<CR>	NO
	Write	Light level for custom mode	<CR>*lampcustom=value#<CR>	NO
	Read	Light level status for custom mode	<CR>*lampcustom=?#<CR>	NO
	Read	Lamp Mode Status	<CR>*lampm=?#<CR>	YES
Miscellaneous	Read	Model Name	<CR>*modelname=?#<CR>	YES
	Write	Blank On	<CR>*blank=on#<CR>	YES
	Write	Blank Off	<CR>*blank=off#<CR>	YES
	Read	Blank Status	<CR>*blank=?#<CR>	YES
	Write	Freeze On	<CR>*freeze=on#<CR>	Yes
	Write	Freeze Off	<CR>*freeze=off#<CR>	YES
	Read	Freeze Status	<CR>*freeze=?#<CR>	YES
	Write	Menu On	<CR>*menu=on#<CR>	YES
	Write	Menu Off	<CR>*menu=off#<CR>	YES
	Write	Up	<CR>*up#<CR>	YES
	Write	Down	<CR>*down#<CR>	YES
	Write	Right	<CR>*right#<CR>	YES
	Write	Left	<CR>*left#<CR>	YES
	Write	Enter	<CR>*enter#<CR>	YES

Write	3D Sync Off	<CR>*3d=off#<CR>	NO
Write	3D Auto	<CR>*3d=auto#<CR>	YES
Write	3D Sync Top Bottom	<CR>*3d=tb#<CR>	YES
Write	3D Sync Frame Sequential	<CR>*3d=fs#<CR>	NO
Write	3D Frame packing	<CR>*3d=fp#<CR>	YES
Write	3D Side by side	<CR>*3d=sbs#<CR>	YES
Write	3D inverter disable	<CR>*3d=da#<CR>	NO
Write	3D inverter	<CR>*3d=iv#<CR>	YES
Write	2D to 3D	<CR>*3d=2d3d#<CR>	NO
Write	3D nVIDIA	<CR>*3d=nvidia#<CR>	NO
Read	3D Sync Status	<CR>*3d=?#<CR>	YES
Write	Remote Receiver-front+rear	<CR>*rr=fr#<CR>	NO
Write	Remote Receiver-front	<CR>*rr=f#<CR>	NO
Write	Remote Receiver-rear	<CR>*rr=r#<CR>	NO
Write	Remote Receiver-top	<CR>*rr=t#<CR>	NO
Write	Remote Receiver-top+front	<CR>*rr=tf#<CR>	NO
Write	Remote Receiver-top+rear	<CR>*rr=tr#<CR>	NO
Read	Remote Receiver Status	<CR>*rr=?#<CR>	NO
Write	Instant On-on	<CR>*ins=on#<CR>	NO
Write	Instant On-off	<CR>*ins=off#<CR>	NO
Read	Instant On Status	<CR>*ins=?#<CR>	NO
Write	Lamp Saver Mode-on	<CR>*lpsaver=on#<CR>	NO
Write	Lamp Saver Mode-off	<CR>*lpsaver=off#<CR>	NO
Read	Lamp Saver Mode Status	<CR>*lpsaver=?#<CR>	NO
Write	Projection Log In Code on	<CR>*prjlogincode=on#<CR>	NO
Write	Projection Log In Code off	<CR>*prjlogincode=off#<CR>	NO
Read	Projection Log In Code Status	<CR>*prjlogincode=?#<CR>	NO

	Write	Broadcasting on	<CR>*broadcasting=on#<CR>	NO
	Write	Broadcasting off	<CR>*broadcasting=off#<CR>	NO
	Read	Broadcasting Status	<CR>*broadcasting=?<CR>	NO
	Write	AMX Device Discovery-on	<CR>*amxdd=on#<CR>	NO
	Write	AMX Device Discovery-off	<CR>*amxdd=off#<CR>	NO
	Read	AMX Device Discovery Status	<CR>*amxdd=?#<CR>	NO
	Read	Mac Address	<CR>*macaddr=?#<CR>	NO
	Write	High Altitude mode on	<CR>*Highaltitude=on#<CR>	YES
	Write	High Altitude mode off	<CR>*Highaltitude=off#<CR>	YES
	Read	High Altitude mode status	<CR>*Highaltitude=?#<CR>	YES
Installation	Write	Load Lens memory 1	<CR>*lensload=m1#<CR>	NO
	Write	Load Lens memory 2	<CR>*lensload=m2#<CR>	NO
	Write	Load Lens memory 3	<CR>*lensload=m3#<CR>	NO
	Write	Load Lens memory 4	<CR>*lensload=m4#<CR>	NO
	Write	Load Lens memory 5	<CR>*lensload=m5#<CR>	NO
	Write	Load Lens memory 6	<CR>*lensload=m6#<CR>	NO
	Write	Load Lens memory 7	<CR>*lensload=m7#<CR>	NO
	Write	Load Lens memory 8	<CR>*lensload=m8#<CR>	NO
	Write	Load Lens memory 9	<CR>*lensload=m9#<CR>	NO
	Write	Load Lens memory 10	<CR>*lensload=m10#<CR>	NO
	Read	Read Lens memory status	<CR>*lensload=?#<CR>	NO
	Write	save Lens memory 1	<CR>*lenssave=m1#<CR>	NO
	Write	save Lens memory 2	<CR>*lenssave=m2#<CR>	NO
	Write	save Lens memory 3	<CR>*lenssave=m3#<CR>	NO
	Write	save Lens memory 4	<CR>*lenssave=m4#<CR>	NO
	Write	save Lens memory 5	<CR>*lenssave=m5#<CR>	NO
	Write	save Lens memory 6	<CR>*lenssave=m6#<CR>	NO
	Write	save Lens memory 7	<CR>*lenssave=m7#<CR>	NO
	Write	save Lens memory 8	<CR>*lenssave=m8#<CR>	NO
	Write	save Lens memory 9	<CR>*lenssave=m9#<CR>	NO

	Write	save Lens memory 10	<CR>*lenssave=m10#<CR>	NO
	Write	Reset Lens to center	<CR>*lensreset=center#<CR>	NO
Color Calibration	Write	Tint +	<CR>*tint=+#<CR>	YES
	Write	Tint -	<CR>*tint=-#<CR>	YES
	Write	Set Tint value	<CR>*tint=value#<CR>	YES
	Read	Get Tint value	<CR>*tint=?#<CR>	YES
	Write	Set BenQ gamma value	<CR>*gamma=value#<CR>	YES
	Read	Gamma value status	<CR>*gamma=?#<CR>	YES
	Write	Set HDR Brightness value	<CR>*hdrbri=value#<CR>	YES
	Read	Get HDR Brightness value	<CR>*hdibri=?#<CR>	YES
	Write	Red Gain +	<CR>*RGain=+#<CR>	YES
	Write	Red Gain -	<CR>*RGain=-#<CR>	YES
	Write	Set Red Gain value	<CR>*RGain=value#<CR>	YES
	Read	Get Red Gain value	<CR>*RGain=?#<CR>	YES
	Write	Green Gain +	<CR>*GGain=+#<CR>	YES
	Write	Green Gain -	<CR>*GGain=-#<CR>	YES
	Write	Set Green Gain value	<CR>*GGain=value#<CR>	YES
	Read	Get Green Gain value	<CR>*GGain=?#<CR>	YES
	Write	Blue Gain +	<CR>*BGain=+#<CR>	YES
	Write	Blue Gain -	<CR>*BGain=-#<CR>	YES
	Write	Set Blue Gain value	<CR>*BGain=value#<CR>	YES
	Read	Get Blue Gain value	<CR>*BGain=?#<CR>	YES
	Write	Red Offset +	<CR>*ROffset=+#<CR>	YES
	Write	Red Offset -	<CR>*ROffset=-#<CR>	YES
	Write	Set Red Offset value	<CR>*ROffset=value#<CR>	YES
	Read	Get Red Offset value	<CR>*ROffset=?#<CR>	YES
	Write	Green Offset +	<CR>*GOffset=+#<CR>	YES
	Write	Green Offset -	<CR>*GOffset=-#<CR>	YES
	Write	Set Green Offset value	<CR>*GOffset=value#<CR>	YES
	Read	Get Green Offset value	<CR>*GOffset=?#<CR>	YES
	Write	Blue Offset +	<CR>*BOffset=+#<CR>	YES
	Write	Blue Offset -	<CR>*BOffset=-#<CR>	YES



Write	Set Blue Offset value	<CR>*BOffset=value#<CR>	YES
Read	Get Blue Offset value	<CR>*BOffset=?#<CR>	YES
Write	Primary Color	<CR>*primcr=value#<CR>	YES
Read	Primary Color Status	<CR>*primcr=?#<CR>	YES
Write	Hue +	<CR>*hue=+#<CR>	YES
Write	Hue -	<CR>*hue=-#<CR>	YES
Write	Set Hue value	<CR>*hue=value#<CR>	YES
Read	Get Hue value	<CR>*hue=?#<CR>	YES
Write	Saturation +	<CR>*saturation =+#<CR>	YES
Write	Saturation -	<CR>*saturation =-#<CR>	YES
Write	Set Saturation value	<CR>*saturation =value#<CR>	YES
Read	Get Saturation value	<CR>*saturation =?#<CR>	YES
Write	Gain +	<CR>*gain=+#<CR>	YES
Write	Gain -	<CR>*gain=-#<CR>	YES
Write	Set Gain value	<CR>*gain=value#<CR>	YES
Read	Get Gain value	<CR>*gain=?#<CR>	YES
Write	Color Gamut Auto	<CR>*cgamut=auto#<CR>	NO
Write	Color Gamut BT.709	<CR>*cgamut=bt.709#<CR>	NO
Write	Color Gamut BT.2020	<CR>*cgamut=bt.2020#<CR>	NO
Write	Color Gamut DCI-P3	<CR>*cgamut=dci-p3#<CR>	NO
Read	Color Gamut Value	<CR>*cgamut=?#<CR>	NO
Write	Dynamic Iris ON	<CR>*diris=on#<CR>	YES
Write	Dynamic Iris OFF	<CR>*diris=off#<CR>	YES
Read	Dynamic Iris status	<CR>*diris=?#<CR>	YES
Write	Set White Red Gain value	<CR>*WRGain=value#<CR>	YES
Write	Set White Green Gain value	<CR>*WGGain=value#<CR>	YES
Write	Set White Blue Gain value	<CR>*WBGain=value#<CR>	YES
Read	Get White Red Gain value	<CR>*WRGain=?#<CR>	YES
Read	Get White Green Gain value	<CR>*WGGain=?#<CR>	YES
Read	Get White Blue Gain value	<CR>*WBGain=?#<CR>	YES



BenQ.com

© 2019 BenQ Corporation

All rights reserved. Rights of modification reserved.

Version: 1.01-C