



Digital Projector User Manual

Home Series | GP500

V 1.00

Product Support

You are strongly recommended to upgrade the product to the latest firmware version and refer to the most up-to-date user manual to make best use of the product.

This document aims to provide the most updated and accurate information to customers, and thus all contents may be modified from time to time without prior notice. Please visit the website for the latest version of this document and other product information. Available files vary by model.

1. Make sure your computer is connected to the Internet.
2. Visit the local website from Support.BenQ.com. The website layout and content may vary by region/country. Look for the following regularly to get the most up-to-date information.
 - User manual and related document
 - Firmware and application
 - Frequently asked questions

Servicing

- If misuse or other accident occurs, contact qualified service personnel for servicing.
- Contact your place of purchase or visit the local website from Support.BenQ.com for more support.



Support.BenQ.com

Q&A Index

Start with the topics you are interested in:

Setup

How do I set up the projector and turn it on?

Choosing a location	20
Operation	24

Image adjustment

How do I adjust the focus of the projected image?

Adjusting the projection angle	30
Fine-tuning the image clarity	31

How to fit the projected image to the screen?

Auto 2D Keystone	32
Corner Fit	33
Screen Fit	34

Usage

How do I use voice control?

Google Assistant	20
------------------	----

How to project wirelessly?

Wireless projection	46
---------------------	----

How do I play music via the projector?

Using the projector as a Bluetooth speaker	48
--	----

Table of Contents

Product Support	2
Servicing	2
Q&A Index	3
Safety Instructions	8
Moisture condensation	10
Avoid volatile liquids.....	10
Disposal.....	10
Package contents	11
Introduction	12
Projector overview	12
Overview	12
I/O ports.....	13
Keypad	13
LED Indicators	14
Dimensions.....	15
Remote control	16
Overview	16
Installing/Replacing the remote control batteries	18
Remote control effective range.....	18
BenQ Smart Control (remote control app)	19
Installation.....	21
Choosing a location.....	21
Obtaining a preferred projected image size.....	22
Projection dimensions	22
Mounting the projector.....	24

Before mounting the projector	24
Operation	25
Installing the ATV dongle	25
Starting up the projector	26
Shutting down the projector	29
Adjusting the projected image	31
Adjusting the projection angle	31
Fine-tuning the image clarity	32
Fitting the image to your screen	33
2D Keystone	33
Corner Fit	34
Zoom adjustment by the zoom ring	35
Screen Fit	35
Object Avoidance	36
Enhancing your cinematic experience	37
Choosing a proper picture mode	37
Advanced settings for better image display	37
User Mode Management	37
Resetting the current picture mode	38
Adjusting audio settings	38
Adjusting the left and right channels of the speakers (for side projection)	39
Accessing more streaming videos	42
Android TV	43
The Android TV home screen	43
Google Assistant	44
Connections	45
Switching between Android TV and input sources	47
Switching between Android TV and input sources	47

Renaming the source	47
Wireless connections	48
Wireless projection.....	48
Wired connections.....	48
Connecting a device with HDMI	48
Connecting a speaker with ARC.....	49
Connecting a USB flash drive	49
Bluetooth connections	50
Using the projector as a Bluetooth speaker	50
Ending the Bluetooth connection	51
Pairing/Connecting to a Bluetooth speaker or headphones	51
Disconnecting a Bluetooth speaker or headphones	52
Menu operation	53
Advanced menu.....	53
Main menu: Picture	53
Main menu: Audio	57
Main menu: Display	58
Main menu: Installation	61
Main menu: System	62
Main menu: Information	64
Navigating the Basic menu	65
Maintenance.....	66
Care of the projector.....	66
Cleaning the lens	66
Storing the projector.....	66
Transporting the projector	66
Light source information.....	67
Getting to know the light hour	67
To obtain the light source information:.....	67
Extending LED life.....	67

Trouble shooting.....	69
Specifications.....	71
Projector specifications	71
Timing chart.....	73
Video timings.....	75
Supported file formats	76
Copyright & disclaimer.....	77
Copyright.....	77
Disclaimer	77
Warranty	77
Statement regarding hyperlinks and third-party websites	78

Safety Instructions

Your projector is designed and tested to meet the latest standards for safety of information technology equipment. However, to ensure safe use of this product, it is important that you follow the instructions mentioned in this manual and marked on the product.

1. Please read this user manual before you operate your projector.
Keep this manual in a safe place for future reference.

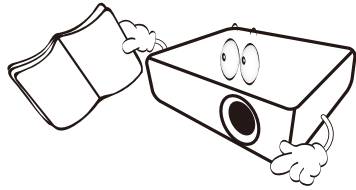

2. Always place the projector on a level, horizontal surface during operation.
 - Do not place the projector on an unstable cart, stand, or table as it may fall and be damaged.
 - Do not place inflammables near the projector.
Do not use if tilted at an angle of more than 10 degrees left to right, nor at angle of more than 15 degrees front to back.

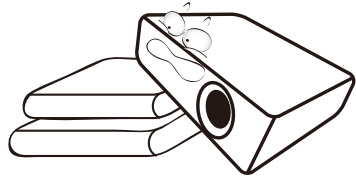

3. Do not store the projector on end vertically. Doing so may cause the projector to fall over, causing injury or resulting in damage.

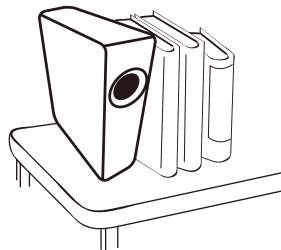

4. Do not place this projector in any of the following environments.

- Space that is poorly ventilated or confined. Allow at least 50 cm clearance from walls and free flow of air around the projector.
- Locations where temperatures may become excessively high, such as the inside of a car with all windows rolled up.
- Locations where excessive humidity, dust, or cigarette smoke may contaminate optical components, shorten the projector's lifespan and darken the screen.

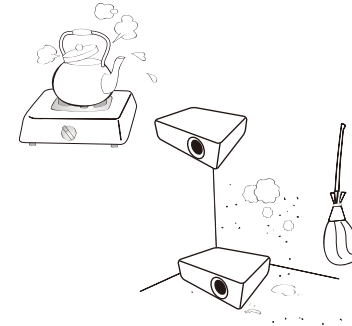

- Locations near fire alarms.
- Locations with an ambient temperature above 40°C /104°F
- Locations where the altitudes are higher than 2000 m (6562 feet).

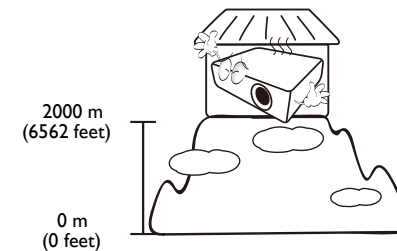

5. Do not block the vents holes while the projector is on (even in power-saving mode).
 - Do not cover the projector with any item.
 - Do not place the projector on a blanket, bedding or any other soft surface.



6. In areas where the mains power supply voltage may fluctuate by ± 10 volts, it is recommended that you connect the projector through a power stabilizer, surge protector or uninterruptible power supply (UPS) as appropriate to your situation.

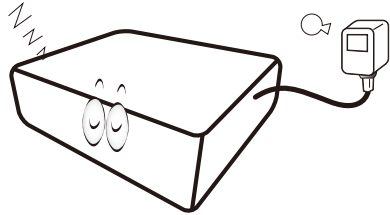

7. Do not step on the projector or place any objects upon it.

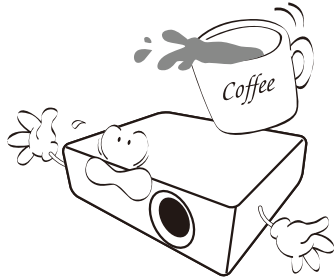

8. Do not place liquids near or on the projector. Liquids spilled into the projector will void your warranty. If the projector does become wet, disconnect it from the power point and call BenQ to have the projector repaired.

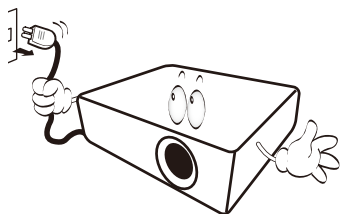

9. Do not look straight into the projector lens during operation. It may harm your sight.

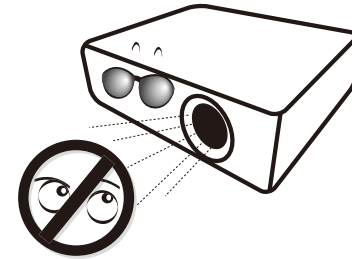

10. Do not operate the projector LED beyond the rated LED life. Excessive operation of LEDs beyond the rated life could cause LEDs to break on rare occasions.

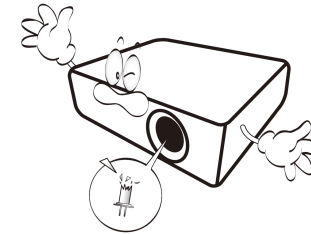

11. Do not attempt to disassemble this projector. There are dangerous high voltages inside which may cause death if you should come into contact with live parts. Under no circumstances should you ever undo or remove any other covers. Refer servicing only to suitably qualified professional service personnel.

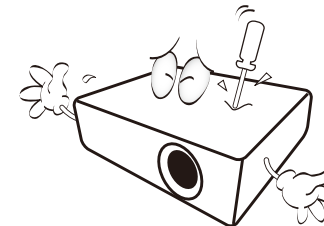

- Please keep the original packing for possible future shipment
- If you need to pack your projector after use, adjust the projection lens to an appropriate position, put the lens cushion around the lens, and fit the lens cushion and projector cushion together to prevent damage during transportation.

12. When you think service or repair is required, take the projector only to a suitably qualified technician.

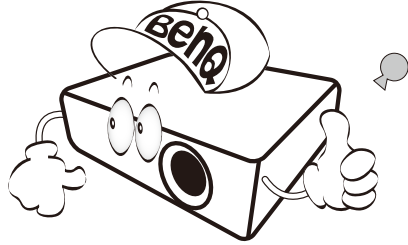

Moisture condensation

Never operate the projector immediately after moving it from a cold location to a hot location. When the projector is exposed to such a change in temperature, moisture may condense on the crucial internal parts. To prevent the projector from possible damage, do not use the projector for at least 2 hours when there is a sudden change in temperature.

Avoid volatile liquids

Do not use volatile liquids, such as insecticide or certain types of cleaner, near the projector. Do not have rubber or plastic products touching the projector for a long time. They will leave marks on the finish. If cleaning with a chemically treated cloth, be sure to follow the cleaning product's safety instructions.

Disposal

This product contains the following materials which are harmful to human bodies and environment.

Lead, which is contained in solder.

To dispose of the product, consult your local environment authorities for regulations.



- The illustrations and the images shown in this document are for your reference.
- The actual content may vary by the product supplied for your region.

Package contents

Carefully unpack and verify that you have all of the items shown below. Some of the items may not be available depending on your region of purchase. If any of these items are missing, please contact your place of purchase.

Standard accessories

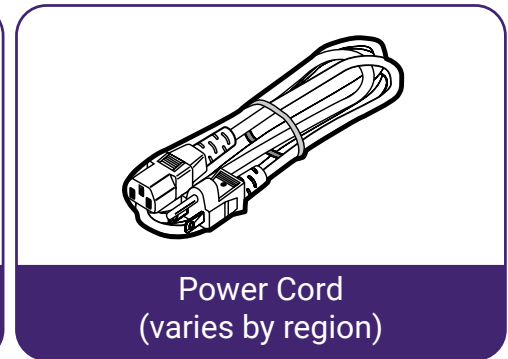
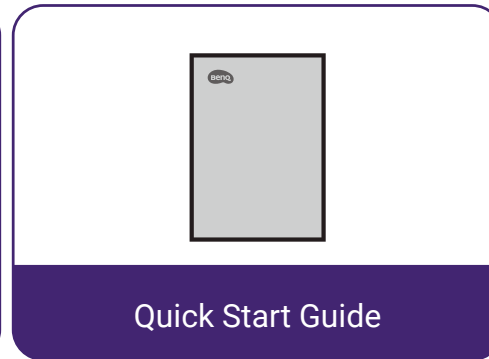
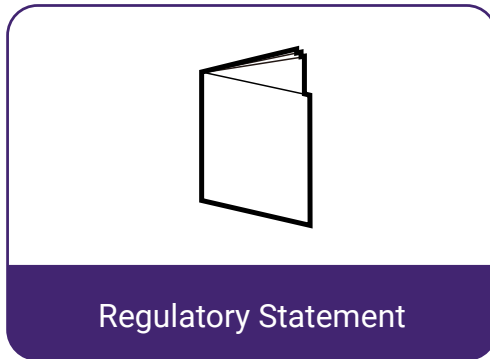
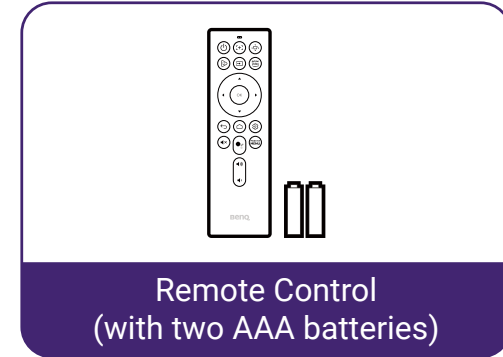
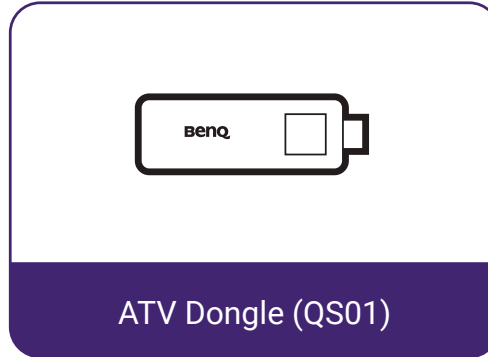

- LED life results will vary depending on environmental conditions and usage. Actual product's features and specifications are subject to change without notice.
- LED replacement is not user-serviceable. When it is needed, please contact the service center.
- Some of the accessories may vary from region to region.
- The warranty card is only supplied in some specific regions. Please consult your dealer for detailed information.
- Use original accessories to ensure compatibility.
- Power cord plug type may change based on regional requirements.

Introduction

Projector overview

Overview

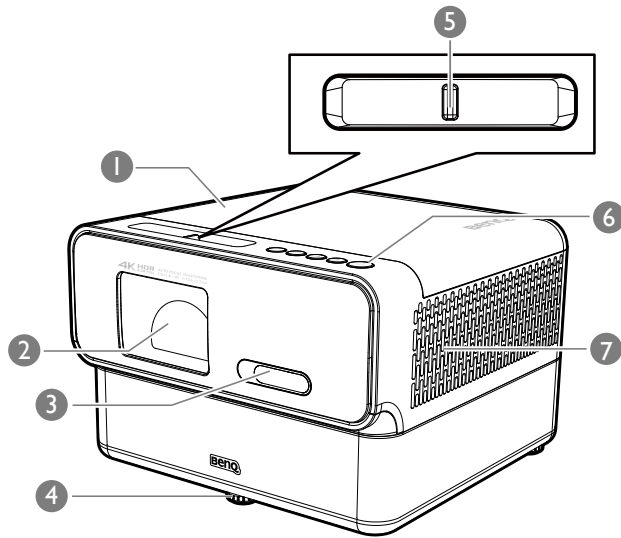

1. Top cover
2. Projection lens
3. IR remote sensor/ Camera for auto focus and keystone
4. Adjuster feet
5. Zoom ring
6. Keypad (see ["Keypad" on page 13](#) for more information.)
7. Vent (air outlet)
8. Wall mount holes

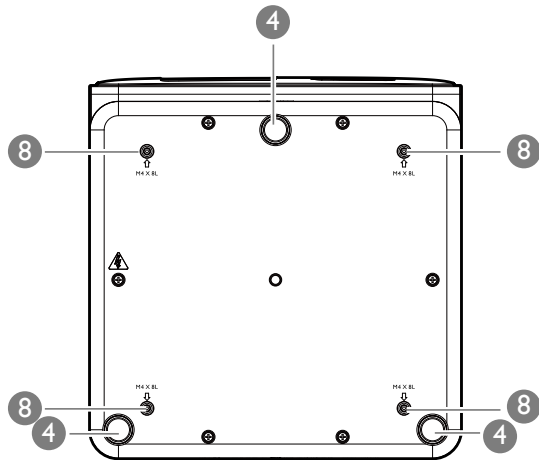

I/O ports

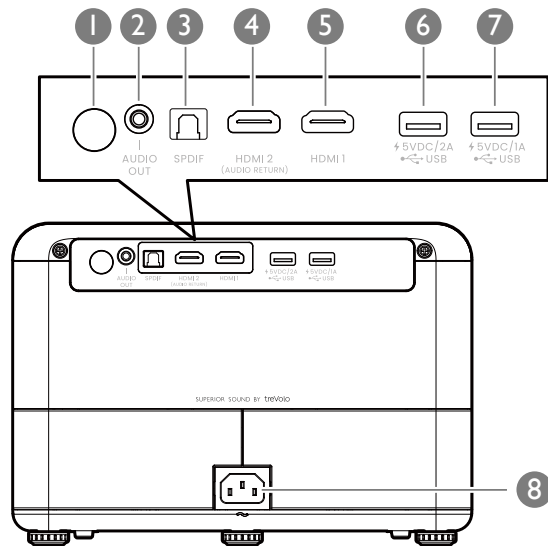

1. IR sensor
2. Audio output jack
3. SPDIF output port
4. HDMI 2 input port
5. HDMI 1 input port
6. USB Type-A port (for power supply up to 5VDC/2.0A)
7. USB Type-A port (for power supply up to 5VDC/1.0A)
8. AC power jack

Keypad

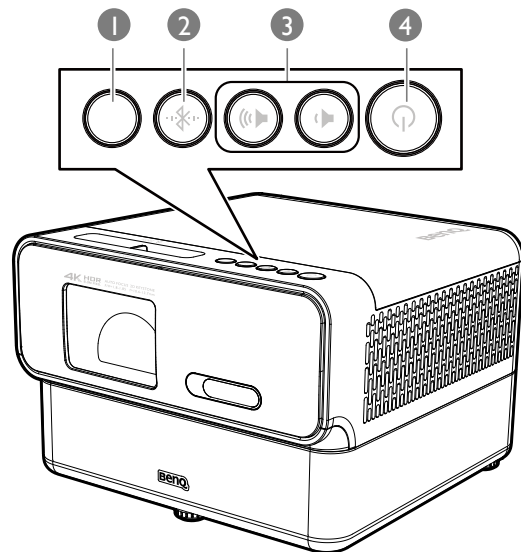

1. Ambient light sensor
2. Bluetooth button and LED indicator
3. Volume +/- keys
4. Power key and LED indicator

LED Indicators

There are power and Bluetooth LED indicators at the top of the projector as illustrated in ["I/O ports" on page 13](#).

Refer to the table below for definitions of various LED behaviors.

Scenario	Status	Power LED indicator	Bluetooth LED indicator
		LED Behavior	LED Behavior
Turning on	Turning projector on	Green - slow flashing	N/A
	After turning on and ready to use	Green - solid	N/A
Turn off	Turning projector off	Green - slow flashing	N/A
	After turning off and back to standby mode	Orange - solid	N/A
Bluetooth speaker mode	Switching to Bluetooth speaker mode	Green - solid	Blue - fast flashing
	Waiting for Bluetooth pairing and connection	Green - solid	Blue - slow flashing
	Disconnecting Bluetooth and entering into Bluetooth speaker idle mode	Green - solid	Blue - solid then slow flashing
	Switching to Projector mode	Green - solid	Blue - solid then off
	Connected successfully or playing music	Green - solid	Blue - solid
	Playing music (during connected)	Green - solid	Blue - solid
	Turning projector off	Green - slow flashing	Blue - solid then off
Error	DLP communication error (I2C connection failed)	Red - flickering	N/A
	Fan error	Red - solid	Refer to Bluetooth speaker mode behavior.
	Temperature error	Red - flickering	Refer to Bluetooth speaker mode behavior.
	Auto focus error	Orange - flickering	N/A

*Restart the projector if there are any errors.

Dimensions

260 (W) x 266.5 (D) x 182.5 (H) mm (without base)

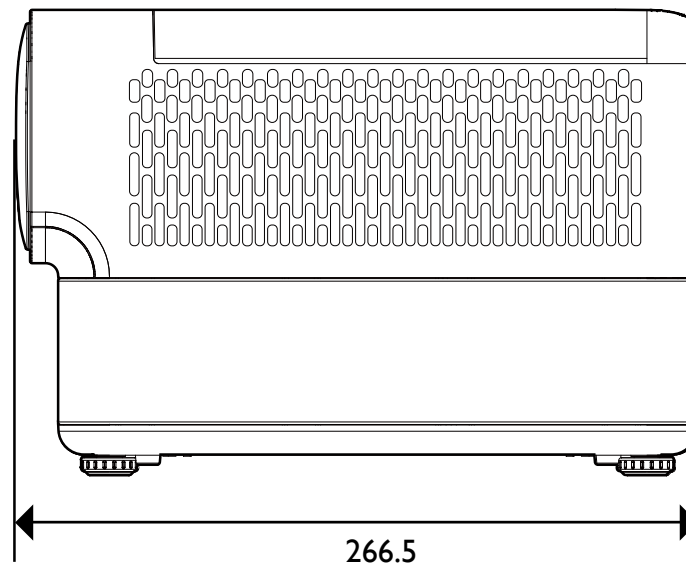
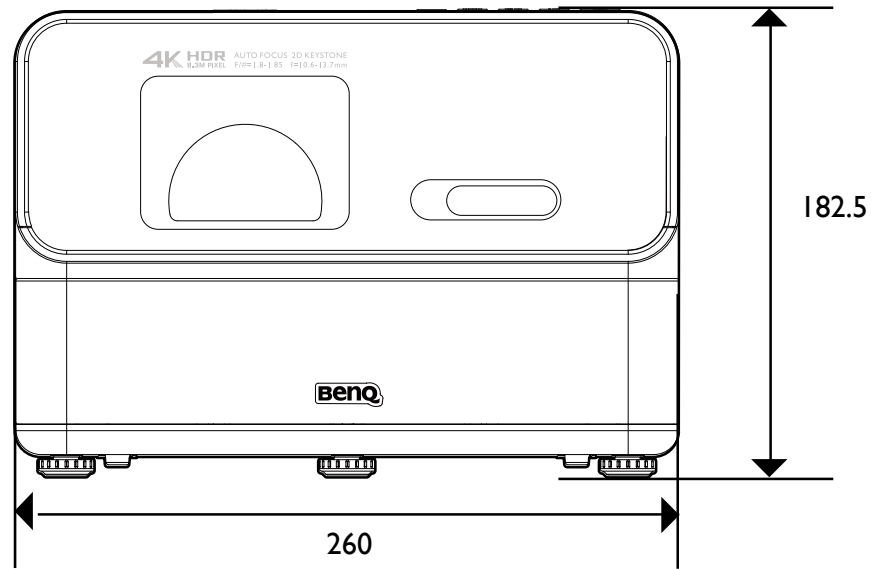

Remote control

Overview

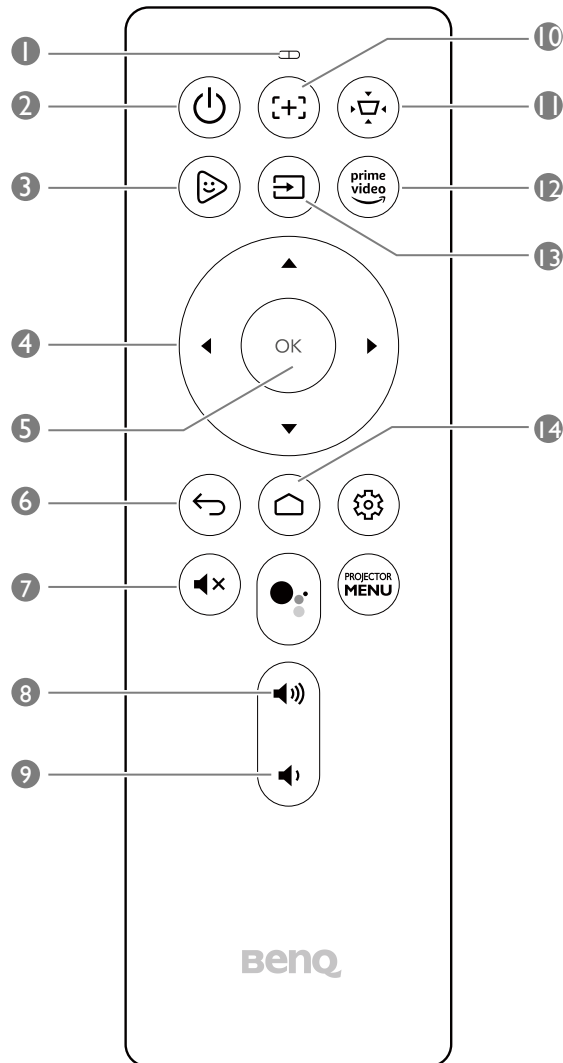

1. **Microphone**
Receives spoken commands for Google Assistant.
2. **POWER**
Turns the projector on or off.
3. **FamiLand**
Launches the FamiLand app in Android TV.
4. **Arrow keys** (◀ Left, ▶ Right, ▼ Up, ▲ Down)
Used as navigation buttons to select the desired menu items and to make adjustments.
5. **OK**
Confirms selections.
6. **BACK**
Returns to the previous menu.
7. **Mute**
Mutes the projector's audio.
8. **Volume Up**
Increases the projector volume.
9. **Volume Down**
Decreases the projector volume.
10. **Focus**
Adjusts the focus for the projector automatically.
11. **Keystone**
Adjusts the keystone for the projector.
12. **Prime Video**
Launches Amazon's Prime Video streaming service.
13. **Source**
Opens the input source menu.
14. **Home**
Returns to the Android TV home menu.

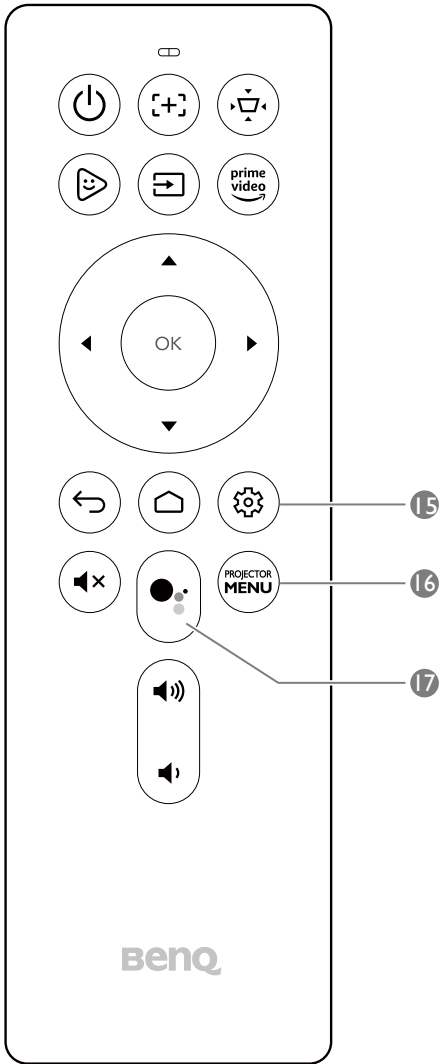

15.  **Settings**

Launches the Android TV settings menu.

16. **PROJECTOR MENU**

Launches the projector's on-screen settings menu.

17. **Google Assistant**

Activates Google Assistant, Google's voice powered virtual assistant service. For more information on Google Assistant, including supported commands and phrases, check Google's official website.

Installing/Replacing the remote control batteries

Before you can begin to use the remote control, you must install the supplied batteries into the remote control.

1. Slide the battery cover outwards.



When sliding the battery cover, do not try to pull the cover too hard as it is tethered to the remote control by a plastic band and cannot be completely removed.

2. Insert the batteries in the orientation shown below.
3. Slide the battery cover back onto the remote control.

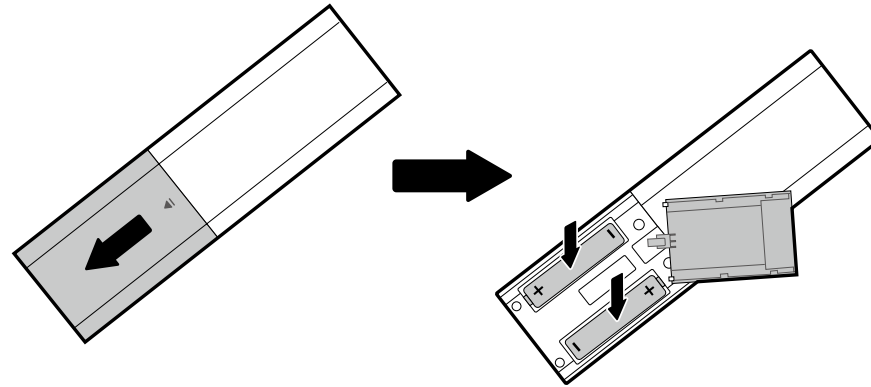

Avoid leaving the remote control and battery in an excessively hot or humid environment like the kitchen, bathroom, sauna, sunroom or in a closed car.

Remote control effective range

The projector has one IR remote control sensor located at the front of the projector with a range of 8 meters (~26 feet) at an angle of 30 degrees (left and right) and 30 degrees (up and down). Prior to remote control pairing process during the setup wizard (see ["Starting up the projector" on page 26](#)), the remote control can only be used either by pointing it directly at the IR sensor or by reflecting the IR signal off of a wall/screen, making sure that there are no obstacles between the remote control and the IR sensor on the projector.

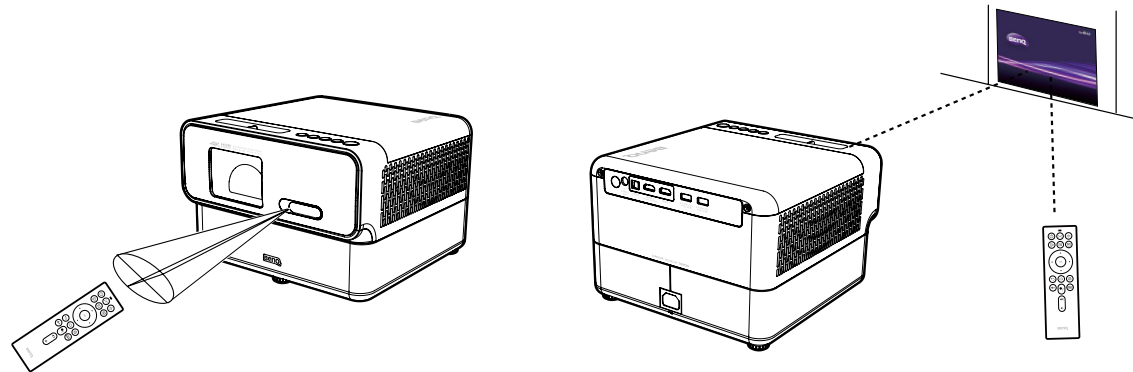

Once the remote control has been paired to the ATV dongle installed in the projector, you will be able to use it at any angle within a range of 8 meters (~26 feet).



Voice input and Google Assistant functionality on the remote control is only available after the remote control has been paired to the projector during the setup wizard process. See "[Starting up the projector](#)" on page 26 for more details.

BenQ Smart Control (remote control app)

The projector also supports the **BenQ Smart Control** app, which lets you transform your Android or iOS device into a remote control to control the ATV dongle (QS01) via buttons and/or touch gestures.

As there are various apps available to you, if you find the supplied remote control does not work well on some of the apps, try with **BenQ Smart Control**.

To begin using the **BenQ Smart Control** app, you need to complete the basic installation and initial setup as instructed in "[Operation](#)" on [page 25](#) first. Refer to the QS01 user manual (available from Support.BenQ.com) or scan the following QR code for instructions on **BenQ Smart Control** download and connection.

How-to video



How to use
Smart Control



- You must be connected to the same wireless network as the projector for **BenQ Smart Control** to work correctly.
- If the app does not automatically connect to your ATV dongle (QS01), or if multiple compatible products are connected to the same network, select the corresponding ATV dongle (QS01) you want to control from the list of products.

Choose one of the following methods to use **BenQ Smart Control**:

- Tap **Mouse** to use touch gestures on your smartphone to control the cursor on the projector similar to a mouse.

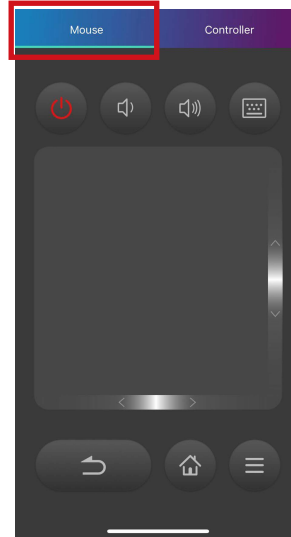

- Tap **Controller** to use the pre-configured buttons in the app to control your projector.

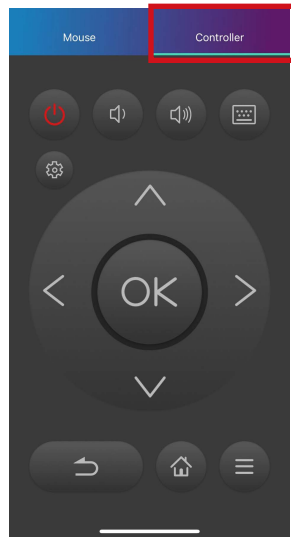

The images are for reference only. The app may be subject to change without prior notice.

Installation

Choosing a location

Before choosing an installation location for your projector, take the following factors into consideration:

- Size and position of your screen
- Electrical outlet location
- Location and distance between the projector and the rest of your equipment
- Location and distance between the projector and the wireless access point

You can install your projector in the following ways:

• **Front**

Select this location with the projector placed near the floor in front of the screen. This is the most common way to position the projector for quick setup and portability. Turn on the projector and select the following settings in the projector's settings menu.

See "[Main menu: Installation](#)" on page 61 for more details:

Installation > Projector Position > Front

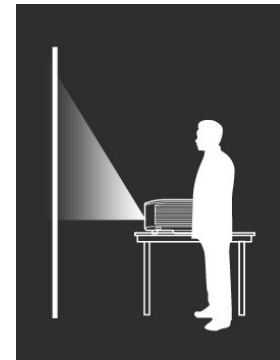

• **Front Ceiling**

Select this location with the projector elevated near the ceiling in front of the screen. Turn on the projector and select the following settings in the projector's settings menu.

See "[Main menu: Installation](#)" on page 61 for more details:

Installation > Projector Position > Front Ceiling



The projector does not feature ceiling mount components/equipment so when choosing to use a front ceiling location you must place it on an elevated location of your choice.

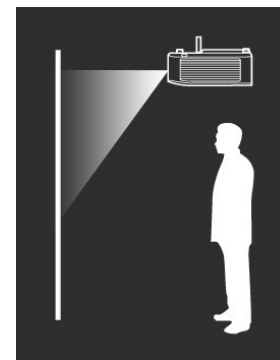

- **Rear**

Select this location with the projector placed near the floor behind the screen.
Turn on the projector and select the following settings in the projector's settings menu.
See "[Main menu: Installation](#)" on page 61 for more details:
Installation > Projector Position > Rear



A special rear projection screen is required.

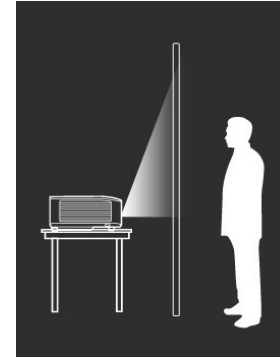

- **Rear Ceiling:**

Select this location with the projector elevated from the ceiling behind the screen.
Turn on the projector and select the following settings in the projector's settings menu.
See "[Main menu: Installation](#)" on page 61 for more details:
Installation > Projector Position > Rear Ceiling



- A special rear projection screen is required.
- The projector does not feature ceiling mount components/equipment so when choosing to use a rear ceiling location you must place it on an elevated location of your choice.

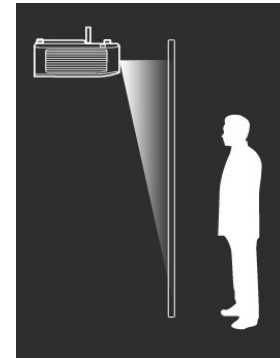

Obtaining a preferred projected image size

The distance from the projector lens to the screen, the zoom setting, and the video format each factors in the projected image size.

Projection dimensions

The screen aspect ratio is 16:9 and the projected picture is in a 16:9 aspect ratio.

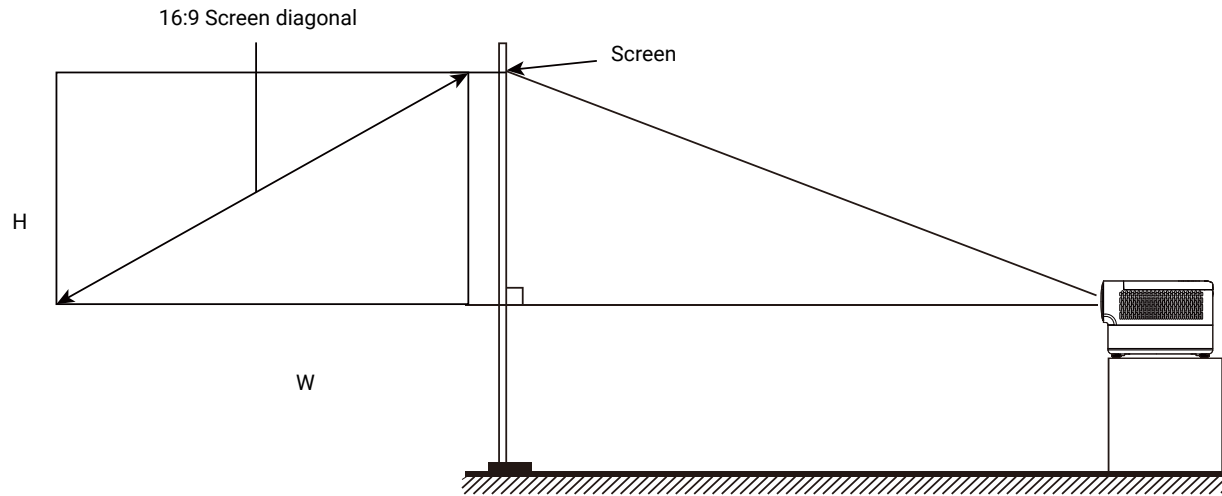

Screen size				Distance from screen (mm)		
Diagonal		H (m)	W (mm)	Min length	Average	Max length
Inch	mm			(max. zoom)		(min. zoom)
40	1016	498	886	890	1020	1150
50	1270	623	1107	1110	1275	1440
55	1397	685	1218	1220	1400	1580
60	1524	747	1328	1330	1530	1730
70	1778	872	1550	1550	1785	2020
80	2032	996	1771	1770	2035	2300
90	2286	1121	1992	1990	2290	2590
100	2540	1245	2214	2220	2550	2880
110	2794	1370	2435	2440	2805	3170
120	3048	1494	2657	2660	3060	3460
130	3302	1619	2878	2880	3310	3740
140	3556	1743	3099	3100	3565	4030
150	3810	1868	3321	3320	3820	4320
160	4064	1992	3542	3550	4080	4610
170	4318	2117	3763	3770	4335	4900
180	4572	2241	3985	3990	4590	5190
190	4826	2366	4206	4210	4840	5470
200	5080	2491	4428	4430	5095	5760

For example, if you are using a 120-inch screen, the recommended projection distance is 2660-3460 mm. If your measured projection distance is 288 cm, the biggest projected screen size is 130-inch, the smallest projected screen size is 110-inch.



To optimize your projection quality, we suggest doing the projection by referring to the values listed in the non-gray rows.



All measurements are approximate and may vary from the actual sizes.

BenQ recommends that if you intend to permanently install the projector, you should physically test the projection size and distance using the actual projector in situ before you permanently install it, so as to make allowance for this projector's optical characteristics. This will help you determine the exact mounting position so that it best suits your installation location.

Mounting the projector

If you intend to mount your projector, we strongly recommend that you use a proper fitting BenQ projector mounting kit and that you ensure it is securely and safely installed.

If you use a non-BenQ brand projector mounting kit, there is a safety risk that the projector may fall down due to an improper attachment through the use of the wrong gauge or length screws.

Before mounting the projector

- Purchase a BenQ projector mounting kit from the place you purchased your BenQ projector.
- BenQ recommends that you also use a security cable to secure both the base of the mounting bracket and the security bar on the projector. This will perform the secondary role of restraining the projector should its attachment to the mounting bracket become loose.
- Ask your dealer to install the projector for you. Installing the projector on your own may cause it to fall and result in injury.
- Take necessary procedures to prevent the projector from falling off such as during an earthquake.
- The warranty doesn't cover any product damage caused by mounting the projector with a non-BenQ brand projector mounting kit.
- Consider the surrounding temperature where the projector is ceiling mounted. If a heater is used, the temperature around the ceiling may be higher than expected.
- Read the user manual for the mounting kit about the range of torque. Tightening with torque exceeding the recommended range may cause damage to the projector and subsequently falling off.
- Make sure the power outlet is at an accessible height so that you can easily shut down the projector.

Operation

Installing the ATV dongle

1. Remove the cap from the provided ATV dongle.
2. Place the projector on a flat and stable surface covered by a protective sheet with its top cover facing up.
3. Use an M3 Phillips screwdriver to release 2 screws counterclockwise as illustrated.
4. Remove the top cover from the projector.

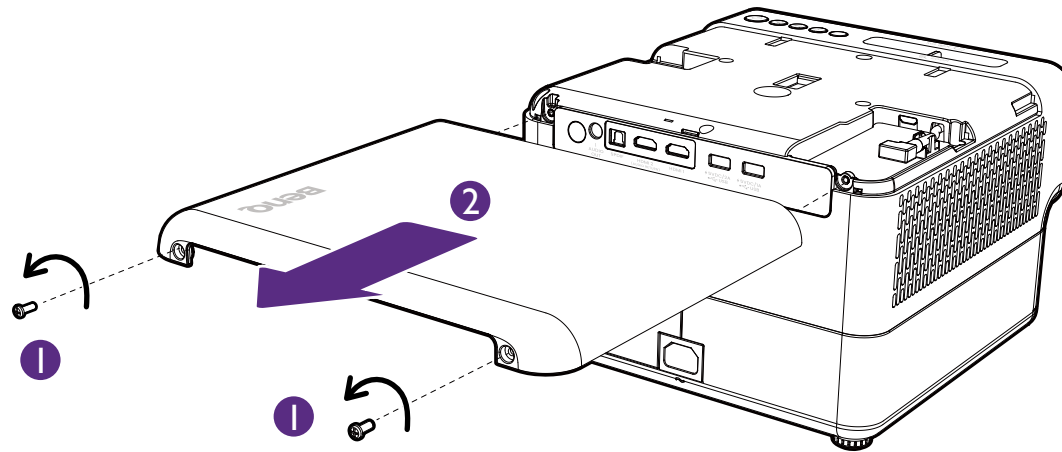

5. Connect the power cable to the port on the side of the dongle and then insert the dongle into the ATV dongle port so that the logo side is facing up.

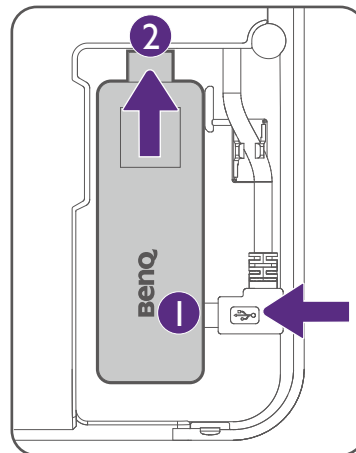

6. Re-install the top cover onto the projector. Use an M3 Phillips screwdriver to fix two screws clockwise as illustrated.

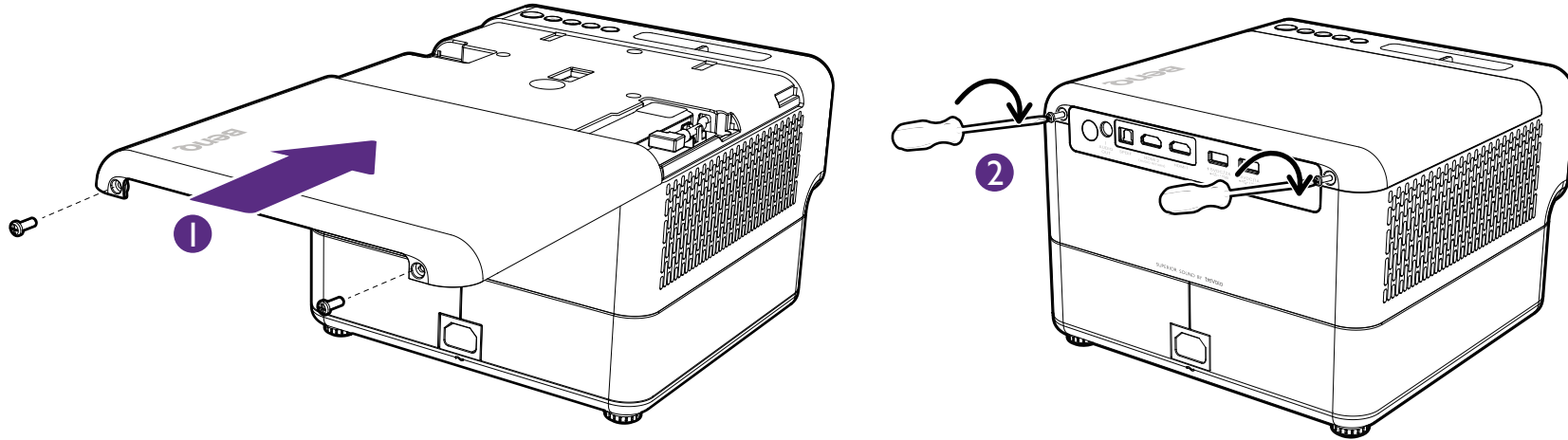

Starting up the projector

! If you are starting up the projector for the first time, it is suggested that the projector is within range of a wireless access point (e.g. a router) with a stable Internet connection as some optional steps during the setup process require Internet access.

1. Install the provided ATV dongle into the ATV dongle port. See "[Installing the ATV dongle](#)" on page 25 for details.
2. Connect AC power cord to your projector and a power outlet.
3. Press the power button  on the projector or the remote control for 1 second. The power LED will flash green slowly.

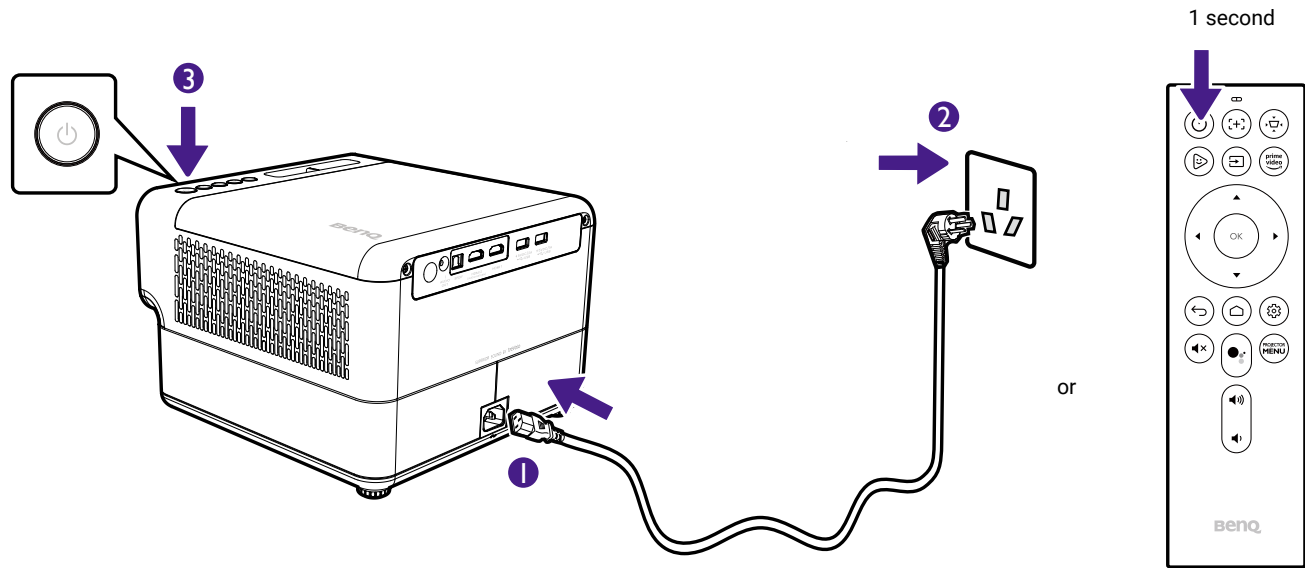

- When supplying power directly to the projector please use the supplied power cable to avoid possible dangers such as electric shock and fire.
- Prior to pairing the remote control to your projector you must ensure that your remote control is in range of the projector's IR sensor. See ["Remote control effective range"](#) on page 18 for more details.
- Powering on via the remote control will not work if you have not completed the setup wizard procedure or if the projector's battery level is below 5%.

4. The fans will start operating and a start-up image will be shown while the projector warms up. This process may take a few minutes. The projector does not respond to further commands while it is warming up.
5. If you are starting up the projector for the first time, the projector's setup wizard will appear to guide you through the initial hardware setup including selecting the projector's positions the system language and correcting keystone. Using your remote control, follow the on-screen instructions to proceed with the process.
6. If you are starting up the projector for the first time, upgrade the projector's firmware to the latest version.

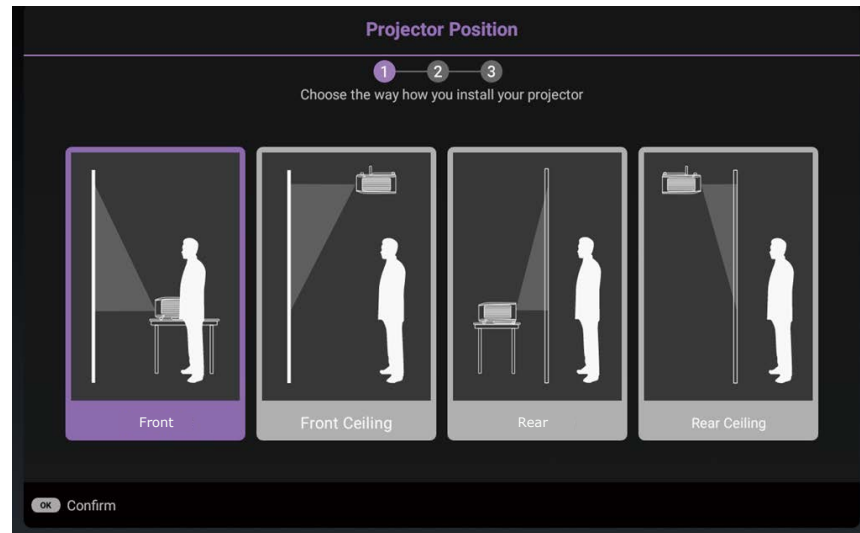

7. Once you've completed the projector's setup wizard, the projector will begin the **Android TV** setup wizard to guide you through setting up the projector's operating system, including steps for pairing the remote control, selecting the language for **Android TV**, setting up a Wi-Fi connection, signing in to a Google account, and other related steps.



- Pairing your remote control to the projector and connecting to a network are required steps in order to proceed with the **Android TV** setup process. You will not be able to use your projector's **Android TV** operating system until you have completed both steps. You will still be able to project via a wired connection if you do not complete the **Android TV** setup process.
- You may proceed with the **Android TV** setup process without signing into a Google account, but you will have limited use of **Android TV**'s services and will be prompted to sign in any time you attempt to use these services.
- To find out how to quickly set up your Google account on the projector, scan one of the QR codes below based on your mobile device's operating system and watch the how-to video.

With iOS device

<https://www.benq.com/en-us/knowledge-center/knowledge/how-to-start-benq-smart-home-projector.html#S1>



With Android device

<https://www.benq.com/en-us/knowledge-center/knowledge/how-to-start-benq-smart-home-projector.html#S2>



8. Once you've completed the **Android TV** setup wizard, the **Android TV** home screen will appear.

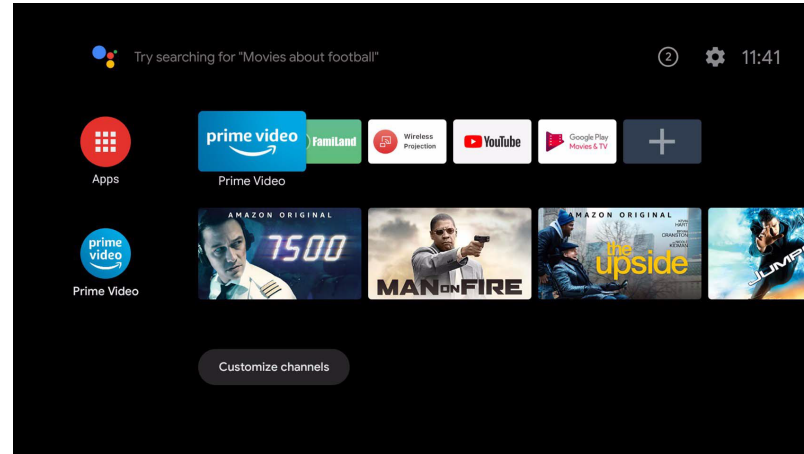

9. Follow the setup wizard to complete the basic settings. By default, the projector enters Android Home screen with the Advanced menu, where you can access complete settings and functions. If you prefer to start with a basic menu with basic settings, go to **System > Menu Settings > Menu Type**.

You may enjoy streaming services now. See ["Android TV" on page 43](#) for more information. Or you may connect a device to the projector to project video. See ["Connections" on page 45](#) for more information.



The screenshots above are for reference only and may differ from the actual design.

Shutting down the projector

Press and hold the power button  on the projector or remote control for over 3 seconds and the projector will shut down directly.



Short pressing the power button on the projector or remote control will trigger a shutdown confirmation box. Under this condition, press the power button again to shut down the projector.

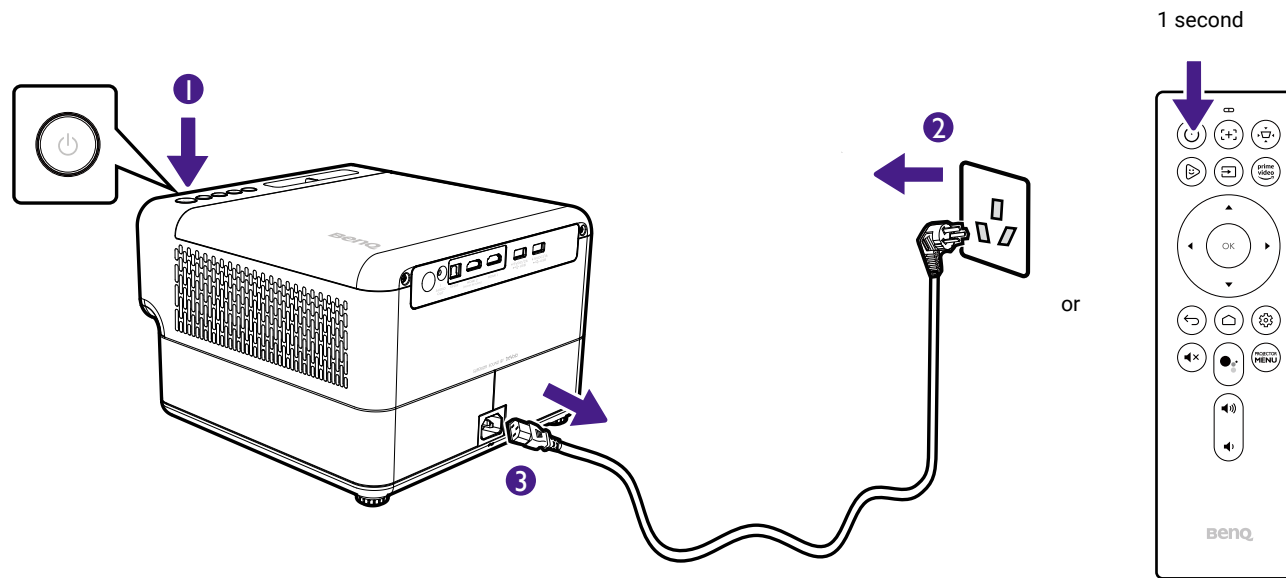

If the projector will not be used for an extended period, unplug the power cable from the power outlet and remove the batteries from the remote control.

Adjusting the projected image

Adjusting the projection angle

The projector adjustment feet allow you to adjust the projection angle.

To adjust the projection angle:

1. Lift the front of the projector and turn the front adjustment feet clockwise. Adjust the appropriate projection height and place the projector horizontally.
2. To retract the feet, turn the feet counterclockwise while raising the projector, then slowly lower the projector.

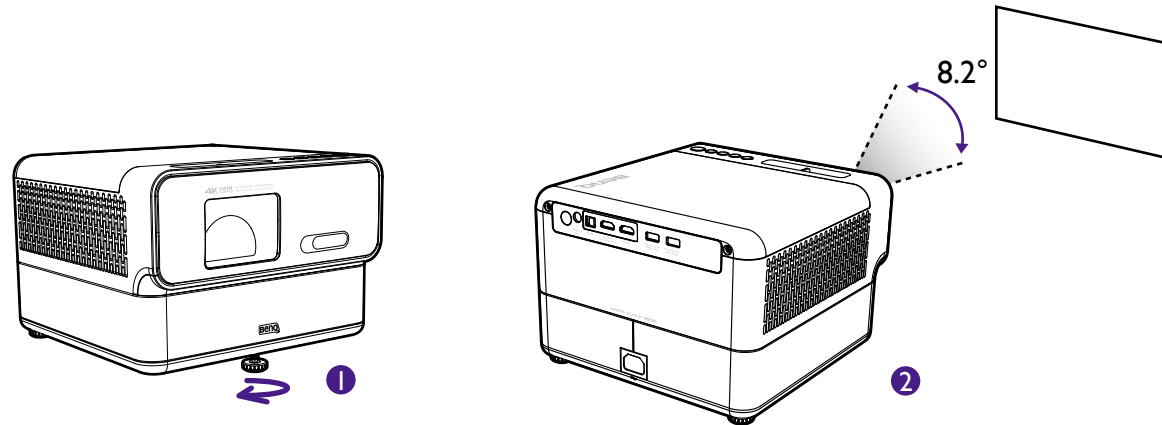

If the desktop is not flat, you can use the adjustment feet on the back to adjust the level of the screen.

1. Place the projector horizontally on the screen and adjust the feet according to the actual situation.
2. Turn the adjusting foot clockwise to adjust.



- The maximum angle of adjustment is 8.2 degrees.
- If the screen and the projector are not perpendicular to each other, the projected image becomes trapezoidal. To correct this, see ["2D Keystone" on page 33](#) for details.

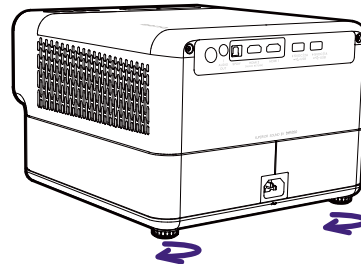



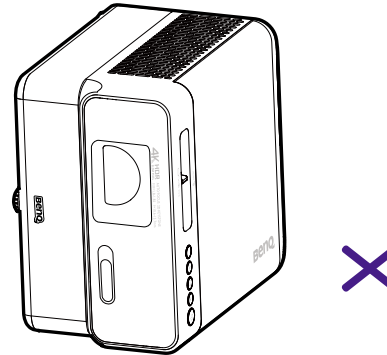

When the projector is on, DO NOT place down the projector with its left or right vents facing down as this will block the vents.

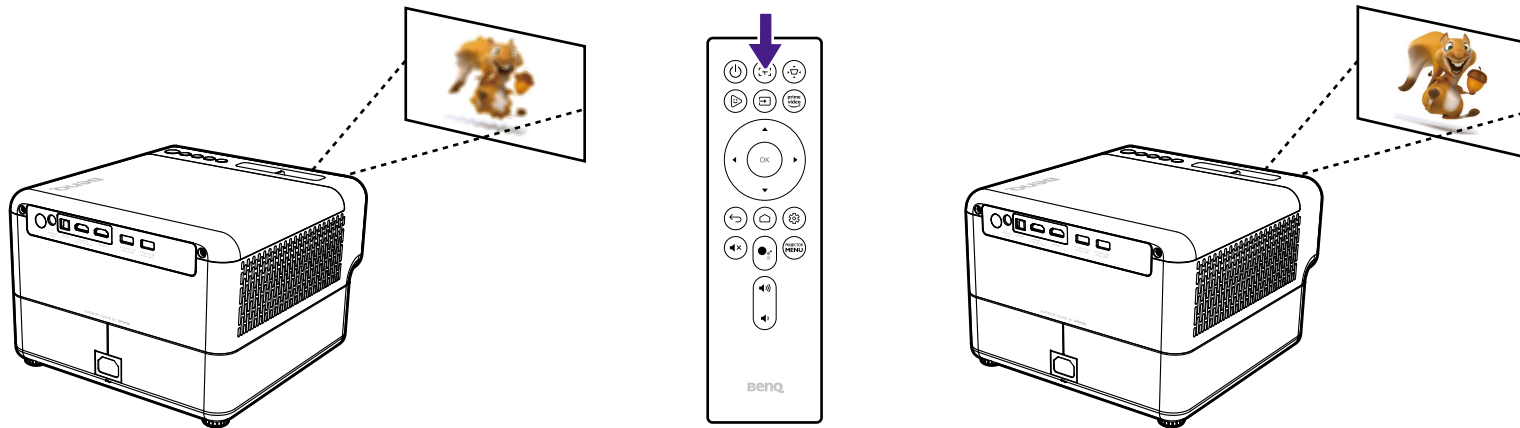

Fine-tuning the image clarity

To sharpen the picture, press the focus button [+] on the remote control and the projector will automatically focus the image.



- Do not look into the lens while the light is on. The strong light from the light may cause damage to your eyes.
- You may also allow the projector to automatically focus the image in the settings menu by configuring the **Auto Focus** setting to **Real Time Adjustment** in the settings menu.
- Each time the projector is moved it will auto focus. When the focus is completed, press  to leave .

Once the projector has finished automatically adjusting the focus, you can also choose to manually adjust the focus by pressing the left ◀ or right ▶ buttons on the remote control while the focus guide is still on the screen.

Fitting the image to your screen

You are provided with several ways to adjust the image and to fit the screen clearly. Depending on the layout of your room, choose one that fits your need. The effect is up to the last adjustment you made. In other words, **2D Keystone**, **Screen Fit**, and **Object Avoidance** functions cannot work together at the same time. If one of them is enabled and adjusted, the other two functions will be disabled and restored to factory default settings.

Note that all except the optical zoom adjustment by the zoom ring may change the image quality. Wait for a few seconds after image adjustment, the image will focus automatically.

2D Keystone

The keystone effect refers to the situation where the projected image is noticeably wider at the top / bottom / left / right. It occurs when the projector is not perpendicular to the screen. The screen automatically performs keystone correction as the projector moves.



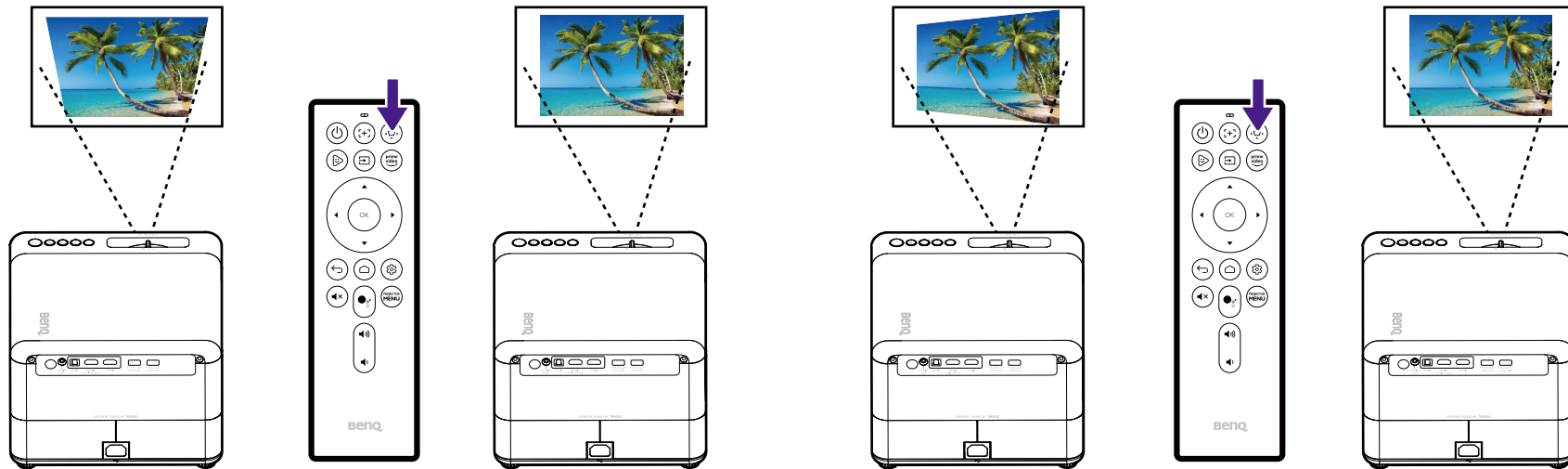

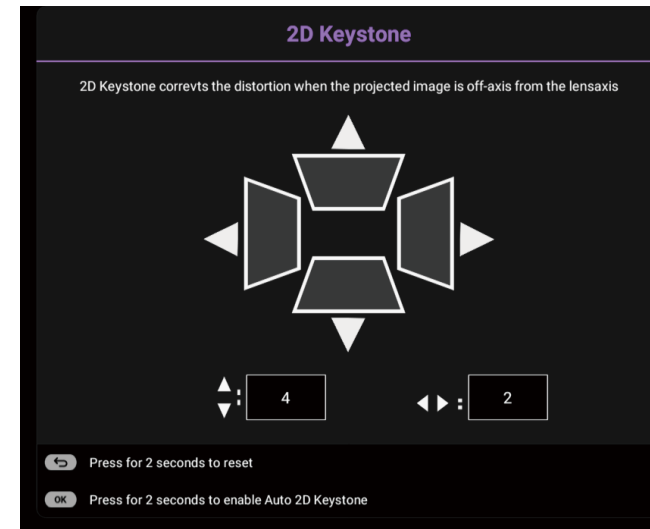
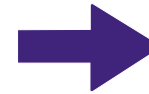
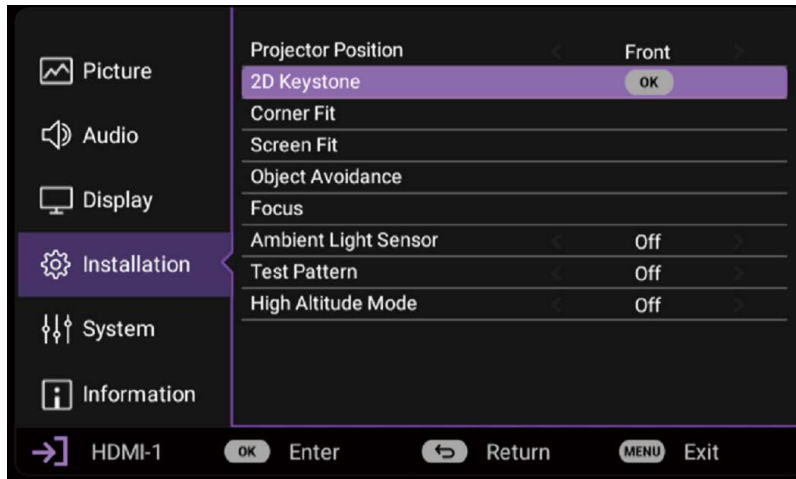
If you want to adjust again, press the  button on the remote control or go to **Menu > Installation > 2D Keystone**, and then follow the on-screen instructions to make the adjustments.





When you are done making the adjustments, press  to save your changes and return to the previous menu.

Corner Fit

Adjust when the four corners of the projected image are distorted. Press the     keys to adjust the item.

1. Press the  button on the remote control to enter the projector's settings menu.
2. Go to **Menu > Installation > Corner Fit**.
3. Choose one of the corners you want to adjust and then follow the on-screen instructions to correct the image.

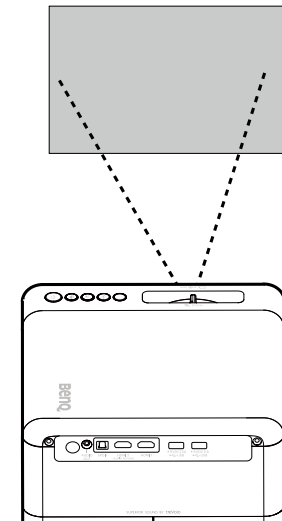
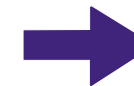
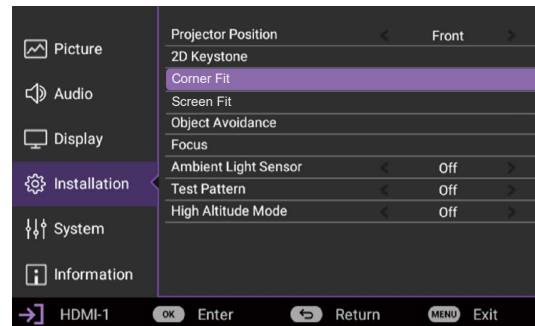
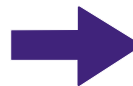
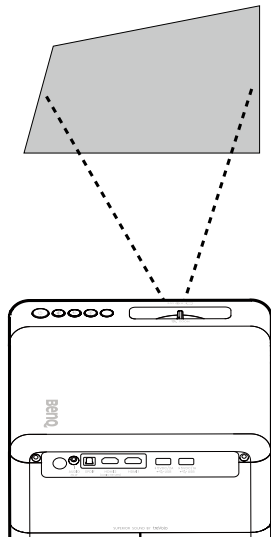

Zoom adjustment by the zoom ring

Use the zoom ring to adjust the optical zoom range of the projector from 1.0 to 1.3x. This will change the size of the image on the screen.

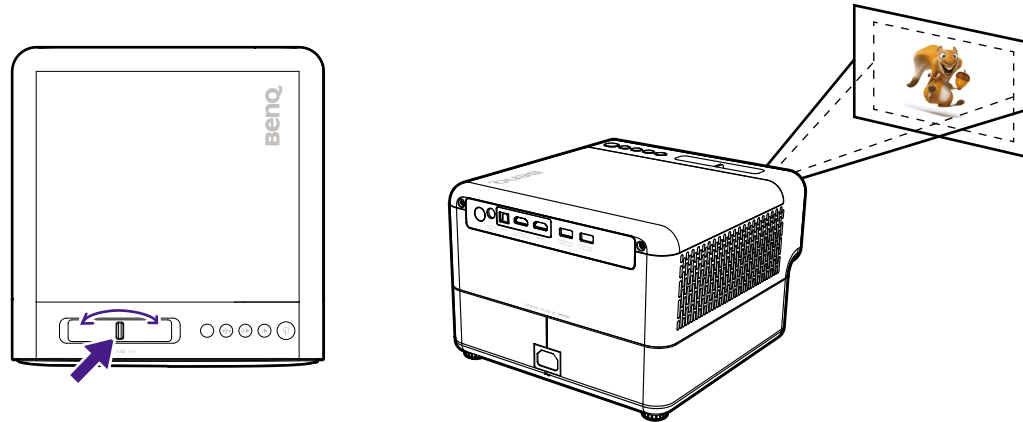

Screen Fit

If the projector is placed off-centered, the image may be distorted. With the **Screen Fit** function, you can adjust the image to align with 3 borders of the screen to fit the screen properly. Note that **Screen Fit** function works only when 3 borders of the screen are detected by the focus/keystone camera.

1. Press the **PROJECTOR MENU** key on the remote control to enter the setting mode.
2. Go to **Menu > Installation > Screen Fit**, press **OK**, the projected image will automatically adjust according to the screen.

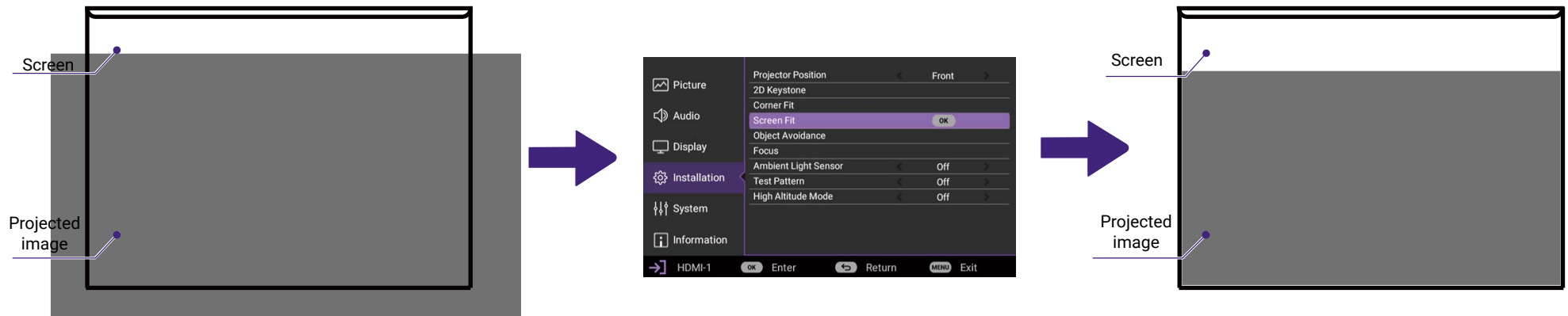



If screen fit function doesn't work, please adjust projector position and make sure that there are at least 3 borders on the screen.

Object Avoidance

With this function, the projector detects if the screen is shaded by any object, and resizes the projected image automatically to avoid the object.

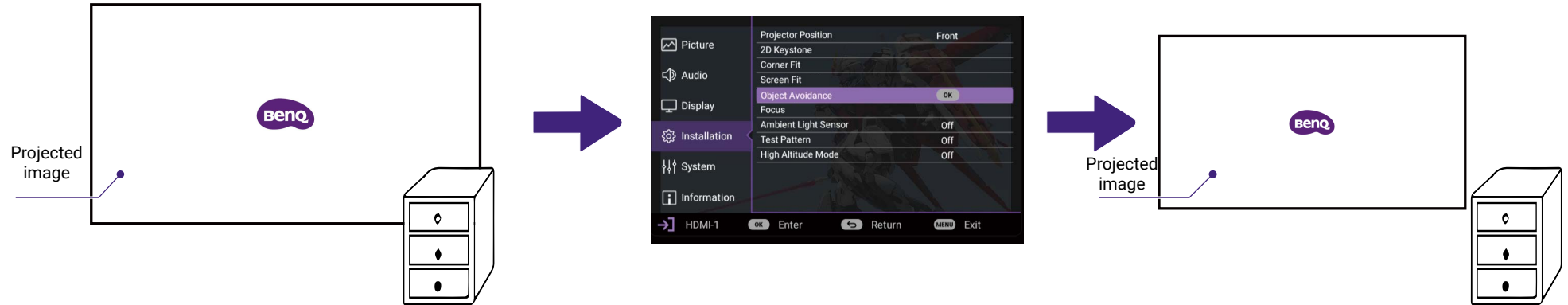
1. Press the **PROJECTOR MENU** key on the remote control to enter the setting mode. Go to **Installation > Object Avoidance**.
2. Press **OK**, the screen will automatically resize to avoid the object shading the screen.



 If **Object Avoidance** function doesn't work, please adjust projector position and make sure there are 4 clear points at the screen corners.

Enhancing your cinematic experience

Choosing a proper picture mode

You are provided with a variety of picture modes for different scenarios in **Picture Mode**. Usually **Cinema** and **Living Room** are recommended for watching movies. For detailed settings and customization, refer to the following. Customize a picture mode as instructed in ["User Mode Management" on page 37](#).

For more color adjustments, go to **Picture > Advanced Color Settings**.

Picture mode	Description
Bright	Maximizes the brightness of the projected image. This mode is the brightest mode on your projector.
Living Room	With well-saturated colors and fine-tuned sharpness, this mode is slightly brighter than Cinema mode and suitable for playing TV streaming under a small amount of ambient light.
Game	Picture settings appropriate for playing video games. This mode especially enhances details in dark scenes so that enemies cannot hide.
Sports	With well-saturated colors, this mode is best for watching sporting events.
Cinema	With accurate colors and deepest contrast at a lower brightness level, this mode is suitable for playing movies in an environment with a bit of ambient light.
(3D)	Optimized to bring up 3D effects when viewing 3D content.
(HDR10)	Delivers High Dynamic Range effects with higher contrasts of brightness and colors.
(HLG)	Delivers Hybrid Long Gamma effects by adding a logarithmic curve with extra brightness over the top of the signal.
User	Accesses the customized settings. See "User Mode Management" on page 37 for more information.

Advanced settings for better image display

- If HDR10 or HLG content is available, you can play the content with DCI-P3 standard to have wider color space and thus better color display. Go to **Advanced Color Settings > Wide Color Gamut** and select **On**. See ["Wide Color Gamut" on page 56](#) for more information.
- To keep out-of-box color consistency of the projector, you are recommended to perform color calibration. Go to **System > Color Calibration > Auto Color Calibration**, and set **Auto**. See ["Color Calibration" on page 63](#) for more information.
- To enjoy smooth fast moving videos, set **Motion Enhancer 4K** from **Advanced Color Settings > CinemaMaster**. See ["Motion Enhancer 4K" on page](#) for more information.

User Mode Management

Customize and name a picture mode as desired. You can save one set of customized picture settings by input source.

Customizing a picture mode

1. Go to **Picture > Picture Mode**.
2. Press ◀ / ▶ to select **User**.
3. Press ▼ to highlight **User Mode Management**, and press **OK**. The **User Mode Management** page is displayed.
4. Select **Load Settings From** to select a preset mode to modify the settings, and press **OK**.
5. Press ▼ / ▲ to select a **Picture Mode** that is closest to your need.
6. Press **OK** and **BACK** to return to the **Picture** menu.
7. Press ▼ to select the **Picture** menu items you want to change and adjust the values with ◀ / ▶ . The adjustments define the selected **User** mode.

Renaming a customized picture mode

Select to rename the customized picture mode (**User**). The new name can be up to 9 characters including English letters (A-Z, a-z), digits (0-9), and space ().

1. Go to **Picture > Picture Mode**.
2. Press ◀ / ▶ to select **User**.
3. Press ▼ to highlight **User Mode Management**, and press **OK**. The **User Mode Management** page is displayed.
4. Press ▼ to highlight **Rename User Mode** and press **OK**. The **Rename User Mode** page is displayed.
5. Use ◀ / ▶ / ▼ / ▲ , and **OK** to set desired characters.
6. When done, press **BACK** to save the changes and exit.

Resetting the current picture mode

Returns all of the adjustments you've made for the selected **Picture Mode** to the factory preset values.

1. Go to **Picture > Reset Current Picture Mode > Reset**.
2. Press **OK**. The confirmation message is displayed.
3. Use ◀ / ▶ to select **Reset** and press **OK**. The current **Picture Mode** returns to the factory preset settings.

Adjusting audio settings

In general, you can select a sound mode from **Audio > Sound Mode** to suit your scenario. As **Cinema** is recommended for movie watching, more options are provided to enhance your cinematic experience. See ["Sound mode" on page 39](#) for more information.

- If the projector is used for side projection and is not aligned centerly with you and the screen in the room, you might want to balance the left/right channels of the speakers depending on the location of your projector. Go to **Audio > Left / Right Channel Settings**. See ["Adjusting the left and right channels of the speakers \(for side projection\)" on page 39](#) for more information.
- To meet your listening preferences, adjust the frequency band of the built-in speakers separately from **User Sound EQ**.
- If external speakers are preferred, connect the speakers first. Go to **Audio > Audio Outputs** to change the settings. Select an appropriate

format from **Audio Output Format** if necessary.

Sound mode	Description
Cinema	This mode emphasizes 360° sound field, just like ideal movie theater, the audience is surrounded by deeper cinematic bass from left to right and front to rear. This mode balances the background music and movie sound effect and especially enhances vocal dialogue for clear whispered voices and stereo bass sound effect for explosive action scene, such as gunshots and firefights. That's why this mode is suitable for various type of movies, such as serious drama, musical and comedy.
Music	This mode emphasizes total balance (low, middle, high frequency) to fully display the timbre of musical instrument, rhythm of symphony and solos of singer in the hot concert or in live hall for different type of music, like pop, rock, and jazz. To reproduce immersive atmosphere or the presence of sound stage, this mode especially enhances the beat of rhythm instruments, the stereo sound space and the vividness of singer.
Game	This mode emphasizes clear position and spatial dynamic to enhance directional sound therefore game player can recognize the direction of gun shot or footsteps from right to left so that enemies can't hide in the action or fighting game.
Sports	This mode allows users to enjoy the rich vividness of sport broadcasts and light entertainment programs. The commentators' voice is clear and high pitch shrill cheers from the audience is processed.
User	This mode is suitable for streaming content such as drama series, TV shows and news broadcast. Besides, in this mode users can adjust audio settings according to their needs.

Adjusting the left and right channels of the speakers (for side projection)

1. Go to **Audio > Left / Right Channel Settings > Projector Position** and select an option according to the actual projector's position. The left and right channels of the speakers will be adjusted automatically according to your selection.

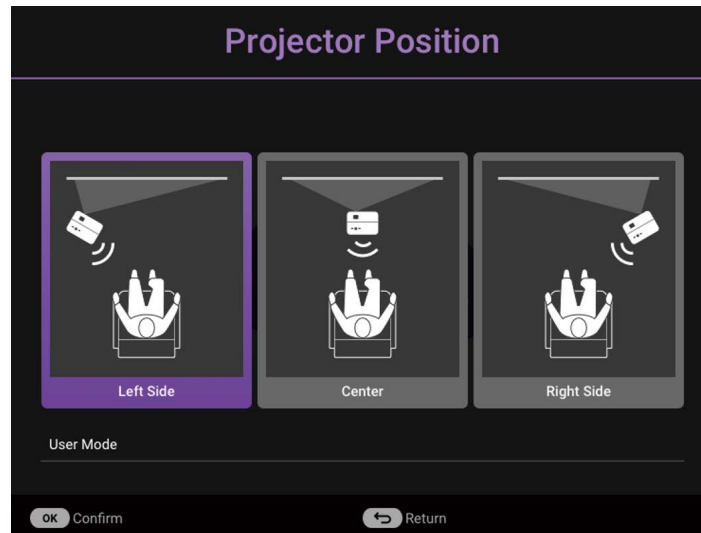

2. If the default speaker settings cannot suit your need, you can customize the speaker channels. Select **User Mode** and press **OK**.

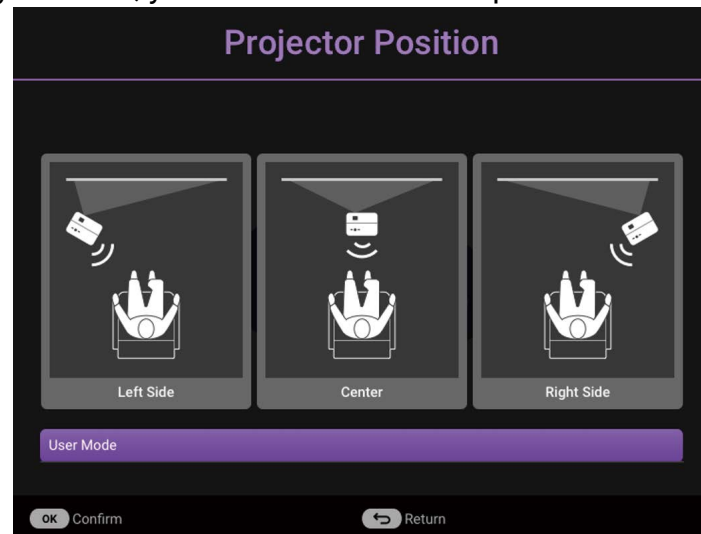

3. You can configure or mute the left and right channels of the 4 speakers from **User Speaker Settings**.

User Speaker Settings

Front Right	<	Right Channel	>
Front Left	<	Left Channel	>
Back Right	<	Right Channel	>
Back Left	<	Mute	>

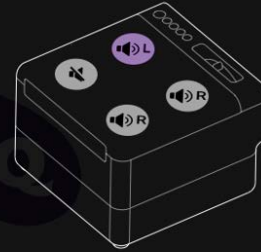

OK Confirm

Return

Accessing more streaming videos

Some streaming service apps are not natively available on your ATV dongle. Refer to the QS01 user manual (available from Support.BenQ.com) for more information.

Refer to the QS01 user manual available from Support.BenQ.com for instructions on how to access more video streaming apps. Before you start, make sure your ATV dongle (QS01) is connected to the Internet.

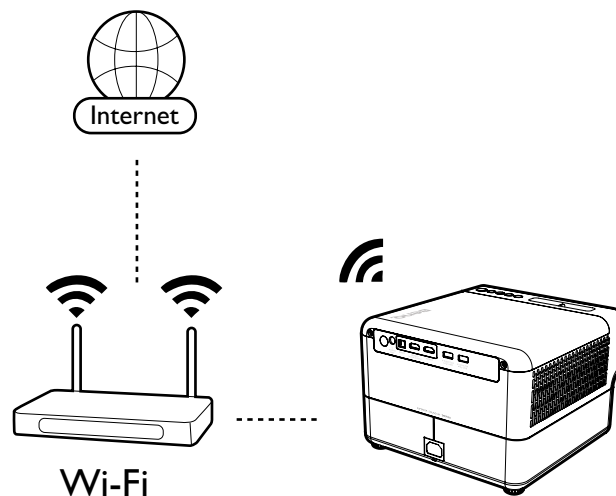

As there are various apps available to you, if you find the supplied remote control does not work well on some of the apps, try with BenQ Smart Control. See "[BenQ Smart Control \(remote control app\)](#)" on page 19 for more information.

Android TV

Android TV is the projector's operating system that allows you to project videos wirelessly and use streaming apps.

The Android TV home screen

Upon initial startup or when the input source is set to ATV the projector will display the **Android TV** interface. If the projector is projecting from a source, you can return to **Android TV** by pressing the  key on your remote control or by selecting ATV in the input source menu.

The **Android TV** home screen features following items:

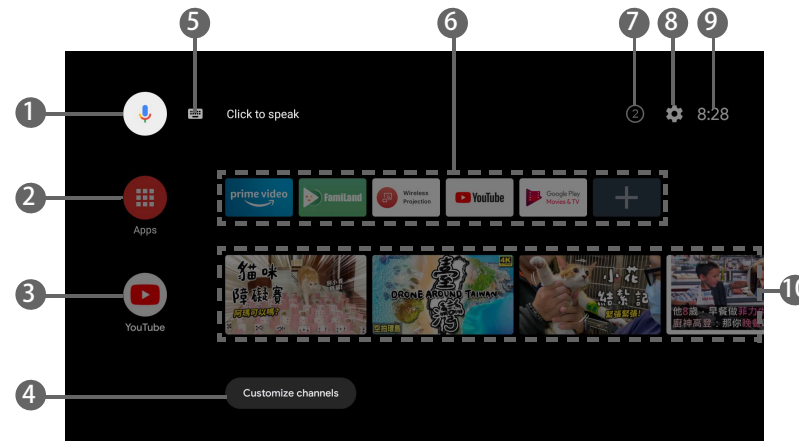

Actual screen may vary based on your **Android TV** version.

No.	Item	Description
1	Google Voice Search / Google Assistant	Enables Google Voice Search / Google Assistant.
2	All apps	Accesses all the installed apps.
3	YouTube	Launches the YouTube app.
4	Customized channels	Allows you to customize app channels that appear on the home screens feed.
5	Search by text	Enables text input to search.
6	Recommended apps or services	Quick access to recommended apps or videos-on-demand services. Select the + button to add app shortcuts to this row.
7	Notifications	Accesses notification(s).
8	Settings	Accesses the Android settings menus.
9	System time	Displays the time.

No.	Item	Description
10	Recommended YouTube videos	Quick access to videos recommended by YouTube.

For more information on **Android TV**, you can use the following resources:

- For How-to videos on **Android TV** and FamiLand, scan the QR code below or go to:
<https://www.benq.com/en-us/knowledge-center/knowledge/how-to-start-benq-smart-home-projector.html>



- For the QS01 ATV dongle user manual, visit Support.BenQ.com.

Google Assistant

Android TV supports Google Assistant, Google's voice powered virtual assistant service, for basic commands and Google searches. To activate Google Assistant press the Google Assistant button  on the remote control and say your command or question into the its microphone. For more information on Google Assistant, including supported commands and phrases, check Google's official website.

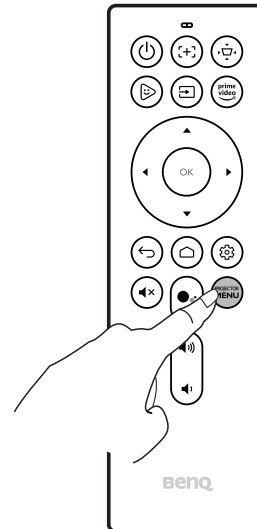

Connections

You can connect your device to the projector in various ways to project video content.

Wireless Connection

- Smartphone, tablet, laptop/PC

Wired Connection (HDMI port)

- A/V device.
- Smartphone, tablet, laptop/PC

Wired Connection(USB-A port)

- USB-A flash drive

Furthermore, you can also connect the projector to Bluetooth speakers/headphones to broadcast audio through the speakers/headphones or connect a mobile device to the projector via Bluetooth to play audio through the projector's speakers.

Before making any wireless connections, be sure to:

- Install the provided ATV dongle for wireless connection.
- Place the projector within range of the wireless AP you plan to connect it to.

Before making any wired connections, be sure to use the correct cable for each source and that it is plugged in securely.

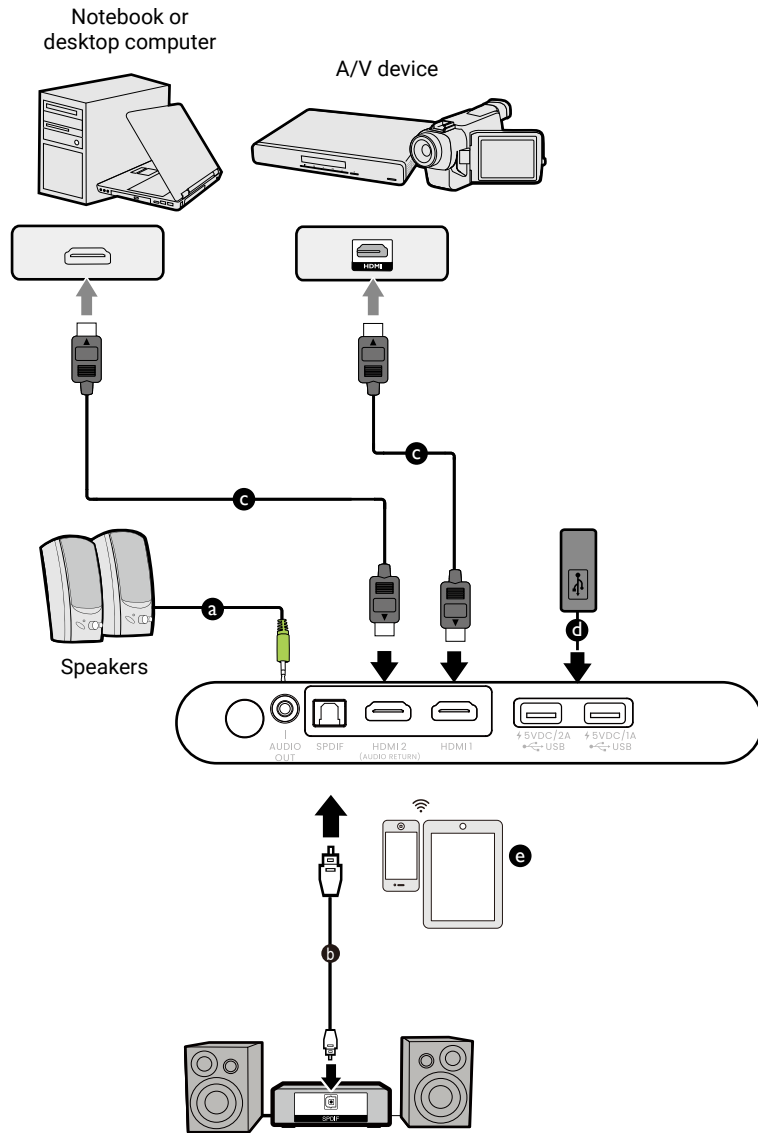

- a. Audio cable
 - b. SPDIF cable
 - c. HDMI cable
 - d. USB flash drive for media reader or firmware upgrade
 - e. Wireless connections
- In the connections above, some cables may not be included with the projector (see [“Standard accessories” on page 11](#)). They are commercially available from electronics stores.
 - The connection illustrations are for reference only.
 - If the selected video image is not displayed after the projector is turned on and the correct video source has been selected, check that the video source device is turned on and operating correctly. Also check that the signal cables have been connected correctly.
 - The built-in speaker(s) will be muted when the AUDIO OUT jack is connected.
 - The illustration above is for reference only.

Switching between Android TV and input sources

By default, the projector will enter the **Android TV** interface any time it is powered on. Once powered on, when a device is connected to one of its input ports the projector will automatically switch over to that input source.

Switching between Android TV and input sources

To switch between input sources and **Android TV**, press the source button  on the remote control and select the desired input source from the source menu.

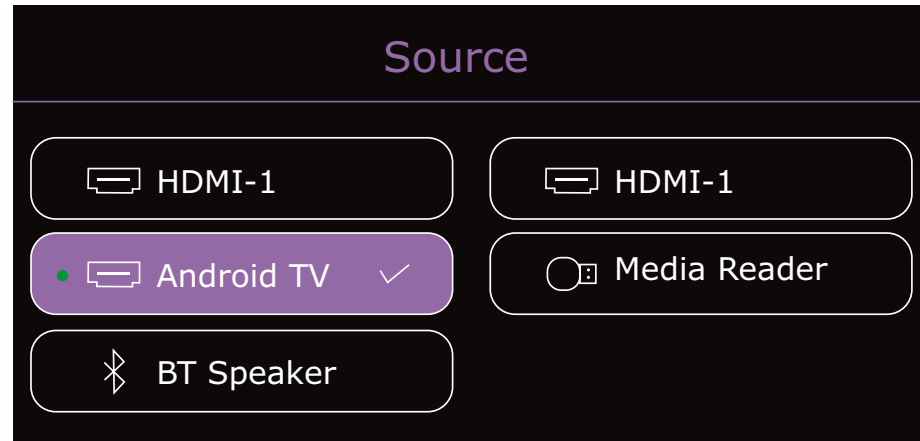

You can also press the home button  on the remote control to return to the **Android TV** home screen at any time.

Renaming the source

Renames the current input source to your desired name.

1. Go to **Display > Source Rename**.
2. Press the **OK** key to display the on-screen keyboard.
3. Press **◀▶▼▲** to select each desired digit/letter, and press the **OK** key to confirm each input.
4. Repeat the step above and when done, press **↵** and to highlight **Commit**.
5. Press the **OK** key and the source name changes.

Wireless connections

Before you can project wirelessly via the projector you must first connect the projector to a wireless network. To connect your projector to a wireless network or to switch wireless networks, use the **Network & Internet** sub-menu in the **Android TV** settings menu.

Wireless projection

To wirelessly connect a device to the projector for the first time, you need to launch the **Wireless Projection** app from the **Android TV** Home screen on the projector to activate the function automatically.

Refer to the QS01 user manual available from Support.BenQ.com or scan the following QR codes for instructions on how to perform wireless projection.

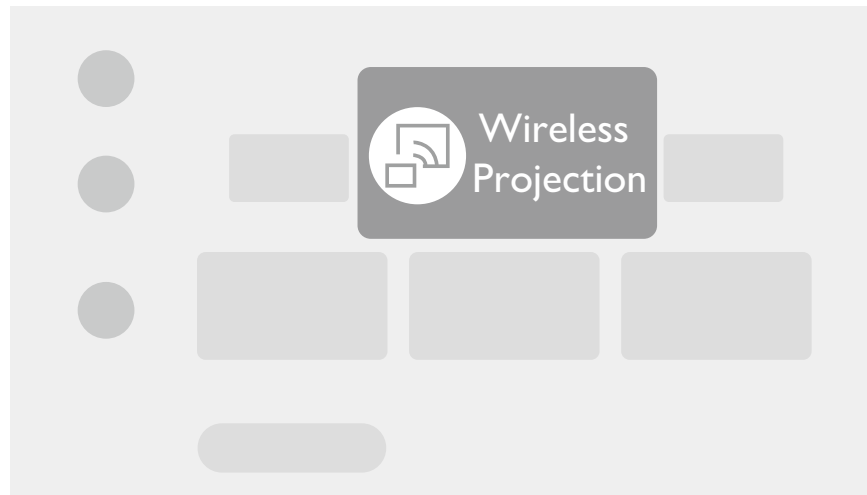

How-to video



Wireless projection from iOS



Wireless projection from Android



- To download the user manual, visit Support.BenQ.com.
- The projector supports wireless projection via the AirPlay (for iOS devices) or Chromecast built-in (for Android devices). As a result, not all Android devices are able to wirelessly project on the projector. To check if your Android device supports wireless casting via Chromecast built-in, check support.google.com.
- Netflix only supports specific authorized devices and is not natively available on BenQ smart home projectors. Please follow the recommended viewing procedures in this how-to video to cast your screen from a projector. Visit Support.BenQ.com and check out the product page for details. Alternatively, see "[Accessing more streaming videos](#)" on [page 42](#) for more information.

Wired connections

Connecting a device with HDMI



Using HDMI cable you can connect a device that is equipped with HDMI capabilities to broadcast videos and images on the projector.

1. Connect the device to the HDMI port on the projector.

2. Confirm whether you want to project video from the device. The video from the device will be displayed once the signal from the device is detected.
-



If no signal is detected or the signal is interrupted a message will appear.

3. Use the source menu or press the home button  to exit and go back to the **Android TV** home screen.
 4. If the device remains connected and you want to project its video again press the source button , and then select the corresponding port in the source menu.
-



- Some computers feature HDMI ports that do not transmit audio, in such cases a separate audio cable must be connected to the projector.
 - Some laptops do not turn on their external video ports when connected to a projector. Usually a key combination like Fn + F3 or CRT/LCD key turns the external display on/off. Locate a function key labeled CRT/LCD or a function key with a monitor symbol on the laptop. Press Fn and the labeled function key simultaneously. Refer to your laptop's documentation to discover your laptop's key combination.
-

Connecting a speaker with ARC

The HDMI-2 port on the projector features Audio Return Channel (ARC) capabilities which allows it to output its audio to an ARC-compatible speaker connected via an HDMI cable.

1. Connect input source to the HDMI-1 port of the projector.
2. Connect the ARC-compatible speakers to the HDMI-2 port of the projector. Disconnect other external speakers if possible.
3. Go to **Audio > Audio Outputs**. Select **Audio Return**. The audio input from HDMI-1 will be output to the ARC-compatible external speakers via HDMI-2.

Connecting a USB flash drive

Connect a USB-A drive to the respective port on the projector to play media files stored on the flash drive.

1. Connect the flash drive to the USB-A.
2. Confirm whether you want to play media files from the device.
3. Select the storage device where the media files are located.
4. Select the type of media file you want to play to view files located on the device.
5. Navigate to and select the media file you want play. The projector's media player will launch.

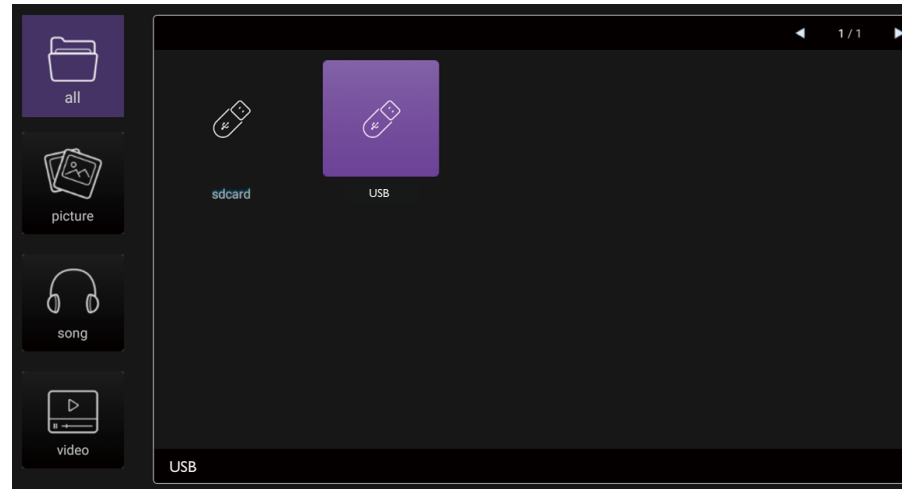



Bluetooth connections

The projector allows the following types of Bluetooth connections:

- Connect a mobile device to the projector to broadcast audio through the projector's speakers.
- Connect to a Bluetooth-enabled speaker or headphones to output audio directly for greater sound.

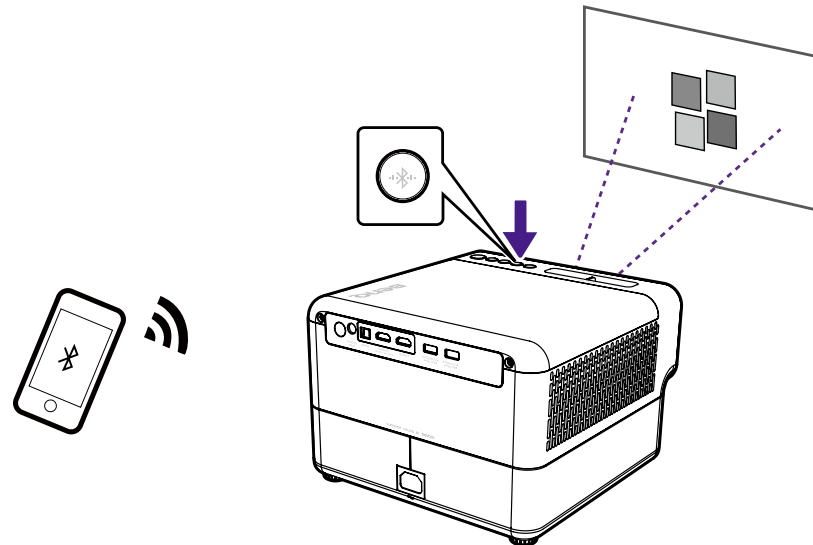
Using the projector as a Bluetooth speaker



1. Make sure the ATV dongle is installed properly (see ["Installing the ATV dongle" on page 25](#)).
2. Power on the projector (see ["Starting up the projector" on page 26](#)).
3. Press the Bluetooth button  on the top side of the projector. The projector will stop projecting and switch over to Bluetooth speaker mode.
4. Pair your mobile device to the projector.



After you have successfully paired your mobile device with the projector, pairing information will be stored on both devices and a connection will automatically be made when Bluetooth is enabled on both devices and both devices are within range of each other.



- You may also enable Bluetooth speaker mode by pressing the source button on the remote control and selecting **Bluetooth Speaker Mode**.
- If you are unable to activate Bluetooth mode or if the Bluetooth LED does not illuminate, shut off the projector and check to see if the ATV dongle is properly installed. See ["Installing the ATV dongle" on page 25](#) for details.

Ending the Bluetooth connection

In cases where you want to disconnect the mobile device from the projector, either:

- Disconnect from the projector in the Bluetooth menu of your mobile device.
- Press the Bluetooth button  on the projector to return the projector to projector mode.
- Press and hold the power button  on the projector or remote control to power off the projector.

Pairing/Connecting to a Bluetooth speaker or headphones

The Bluetooth function for your projector is built in the Android system, whose hardware is independent of other input sources like HDMI. Thus, the Bluetooth function will only be available when using the projector's built-in Android as an input source. In other words, due to current hardware limitations, the projector won't be able to transmit audio using HDMI to external Bluetooth speakers. If you have any further questions, please contact your local customer care team for more assistance.

1. Make sure the ATV dongle is installed properly (see ["Installing the ATV dongle" on page 25](#)).
2. Power on the projector (see ["Starting up the projector" on page 26](#)).
3. Press the settings button  on the remote control
4. Select **Remotes & Accessories**.
5. Select **Add Accessories**.
6. Activate Bluetooth-pairing mode on the speaker or headphones.
7. Select the speaker or headphones from the device list shown on screen.
8. Select **Pair**.

When the projector and speaker or headphones have successfully connected, the device will be labelled as Connected in the **Remotes & Accessories**. You can now output the audio from the ATV to the speaker or headphone.



-
- The projector can only transmit audio from ATV via Bluetooth connection. Even when the projector is switched to other input sources, such as HDMI, as ATV is still running in the background, it will continue to transmit audio from ATV to the connected Bluetooth speaker or headphones.
 - The projector does not support automatic re-connections with previously paired devices. In order to re-connect to a paired device or connect to another device, repeat the steps above.
-

Disconnecting a Bluetooth speaker or headphones

To disconnect a Bluetooth speaker or headphone from the projector so that it no longer outputs the projector's audio:

1. Press the settings button  on the remote control
2. Select **Remotes & Accessories**.
3. Select the speaker or headphones you want to disconnect from the device list shown on screen.
4. Select **Unpair**.

Menu operation

Please note that the on-screen display (OSD) menus vary according to the signal type selected and the projector model you are using. The menu items are available when the projector detects at least one valid signal. If there is no equipment connected to the projector or no signal detected, limited menu items are accessible.

Advanced menu

Main menu: **Picture**

Structure

Menu	Options	
Picture Mode	Bright / Living Room / Game / Sports / Cinema / 3D / HDR10 / HLG / User	
User Mode Management	Load Settings From	Bright / Living Room / Game / Sports / Cinema
	Rename User Mode	
Fast Mode	Off / On	
Brightness	0 ~100	
Contrast	0 ~100	
Color	0 ~100	
Tint	0 ~100	
Sharpness	0~15	
Advanced Color Settings	Gamma Selection	1.8 / 2.0 / 2.1 / 2.2 / 2.3 / 2.4 / 2.5 / 2.6 / BenQ
	Color Temperature Tuning	Color Temperature / R Gain / G Gain / B Gain / R Offset G Offset / B Offset
	Color Management	R / G / B / C / M / Y / K / White Balance
	Wide Color Gamut	Off / On
	CinemaMaster	Color Enhancer / Flesh Tone / Pixel Enhancer 4K / Motion Enhancer 4K
	Light Source Mode	Normal / ECO / SmartEco
	HDR Brightness	-2 / -1 / 0 / 1 / 2
	Noise Reduction	Low / Middle / High / Off
Reset Current Picture Mode	Reset / Cancel	

Advanced Color Settings (Continued)

- **Color Temperature**

When **Bright** is selected for **Picture Mode**, the color temperature switches to **Native**, and cannot be changed.

- **Native:** With the light source's original color temperature and higher brightness, this setting is suitable for environments where high brightness is required, such as projecting pictures in well lit rooms.
- **Normal:** Maintains normal colorings for white.
- **Cool:** Makes images appear bluish white.
- **Warm:** Makes images appear reddish white.

You can also set a preferred color temperature by adjusting the following options.

- **R Gain / G Gain / B Gain:** Adjusts the contrast levels of Red, Green, and Blue.
- **R Offset / G Offset / B Offset:** Adjusts the brightness levels of Red, Green, and Blue.

- **Color Management**

The Color Management provides six sets white balance of colors to be adjusted.

When you select each color, you can independently adjust its range and saturation according to your preference.

To make adjustments, press the ▼/▲ arrows to highlight an independent color from among Red (R), Green (G), Blue (B), Cyan (C), Magenta (M), or Yellow (Y), and press **OK**. The following menu items are displayed for your choice.

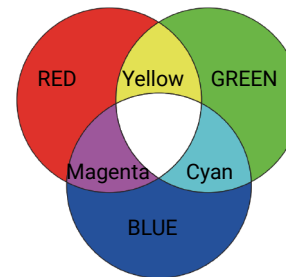

- **Hue:** Increase in the range will include colors consisted of more proportions of its two adjacent colors. Please refer to the illustration for how the colors relate to each other. For example, if you select Red and set its range at 0, only pure red in the projected picture will be selected. Increasing its range will include red close to yellow and red close to magenta.
- **Saturation:** Adjusts the values to your preference. Every adjustment made will reflect to the image immediately. For example, if you select Red and set its value at 0, only the saturation of pure red will be affected.

Menu	Descriptions
<p>Advanced Color Settings (Continued)</p>	<ul style="list-style-type: none"> • Gain: Adjusts the values to your preference. The contrast level of the primary color you select will be affected. Every adjustment made will reflect to the image immediately. If you selected White Balance (W), you can adjust the contrast levels of Red, Green, and Blue by selecting R Gain, G Gain, and B Gain. To return all the settings to the factory default values, highlight Reset, and press OK. •  Saturation is the amount of that color in a video picture. Lower settings produce less saturated colors; a setting of "0" reMOVes that color from the image entirely. If the saturation is too high, that color will be overpowering and unrealistic. • Wide Color Gamut Color Gamut refers to the range of colors that can potentially be displayed by a device. There are some standards to define difference levels of color gamuts for display devices, such as Rec. 709, DCI-P3, BT2020, etc. Selecting On enables the color filter module to extend its color gamut to DCI-P3. This function is only selectable when HDR10 or HLG is selected. With this projector, selecting On will automatically apply the most suitable color gamut to the image source. • CinemaMaster <ul style="list-style-type: none"> • Color Enhancer: Allows you to fine-tune the saturation of colors with larger flexibility. It modulates complex color algorithms to flawlessly render saturated colors, fine gradients, intermediate hues and subtle pigments. • Flesh Tone: Provides a smart adjustment of hue only for calibrating people's skin color, not other colors in the image. It prevents discoloration of skin tones from the light of the projection beam, portraying every skin tone in its most beautiful shade. • Pixel Enhancer 4K: It is a super-resolution technology which radically enhances Full HD content in terms of colors, contrast, and textures. It's also a Detail Enhancement Technology refines surface details for true-to-life images that pop off the screen. Users can adjust levels of sharpness and detail enhancement for optimal viewing. • Motion Enhancer 4K: You can use this feature to smooth fast-MOVing videos by comparing consecutive image frames and inserting an intermediate image frame between them. • Light Source Mode Selects a suitable light source power from among the provided modes. See "Extending LED life" on page 65.

Menu	Descriptions
Advanced Color Settings (Continued)	<ul style="list-style-type: none"> • HDR Brightness The projector can automatically adjust the brightness levels of your image according to the input source. You can also manually select a brightness level to display better picture quality. When the value is higher, the image becomes brighter; when the value is lower, the image becomes darker. • Noise Reduction Reduces electrical image noise caused by different media players.
Reset Current Picture Mode	You can reset to factory defaults. See "Renaming a customized picture mode" on page 37 for more information.

Main menu: **Audio**

Structure

Menu	Options
Sound Mode	Cinema / Music / Game / Sports / User
User Sound EQ	100Hz / 300Hz / 1kHz / 3kHz / 10kHz -10 ~ +10
Audio Outputs	treVolo / SPDIF / Audio Return / 3.5mm Jack
Audio Output Format	LPCM / RAW
Mute	Off / On
Volume	0 ~ 50
Left / Right Channel Settings	Projector Position Center / Right Side / Left Side / User Mode
	User Speaker Settings Front Left / Front Right / Back Left / Back Right
	Left/Right Channel Balance Left 0 ~ 100 / Right 0 ~ 100
Reset Audio	Reset / Cancel

Function descriptions

Menu	Descriptions
Sound Mode	Sound Mode utilizes sound enhancement technology, which incorporates Waves' algorithms to deliver great effects of the bass and treble and provide you with immersive cinematic audio experience. See "Sound mode" on page 39 for details.
User Sound EQ	Select desired frequency bands (100Hz/300Hz/1kHz/3kHz/10kHz) to adjust the levels according to your preference. The settings made here define the User mode.

Menu	Descriptions
Audio Outputs	Selects the audio output from internal or external speakers. To enjoy S/PDIF digital sound effect, make sure the SPDIF connector on the projector is connecting to a compatible audio system. To enjoy Audio Return sound effect, make sure to turn on the ARC function from your soundbar as well. Audio Return supports multi audio outputs including 2.0 and 5.1channel to external audio system like soundbar.
Audio Output Format	The following audio output formats are provided to achieve the audio performance you desire: LPCM supports 2 channel audio output, RAW supports 5.1 channel audio output(Only Dolby Digital).
Mute	Select On to temporarily turn off the projector's internal speaker or the volume being output from the audio output jack.To restore the audio, select Off .
Volume	Adjusts the volume level of the projector's internal speaker or the volume being output from the audio output jack. If the Mute function is activated, adjusting Volume will turn off the Mute function.
Left / Right Channel Settings	To switch L/R channel by different projector positions.See" Adjusting audio settings " on page 38 for details.
Reset Audio	Returns all of the adjustments you've done under the Audio menu to the factory preset values.

Main menu: **Display**

Structure

Menu	Options	
Aspect Ratio	Auto / 4:3 / 16:9	
Auto Source Search	Off / On	
Source Rename	HDMI-1 / HDMI-2	
3D	3D Mode	Auto / Frame Sequential / Frame Packing / Side by Side / Off
	3D Sync Invert	DisableInvert
HDMI Settings	HDMI Format	Auto / Limited / Full
	HDMI Equalizer	HDMI-1 / HDMI-2
	HDMI EDID	HDMI-1 / HDMI-2
	Electronics Control	Off / On
	Power On Link	Off / From Device
	Power Off Link	Off / From Projector
Reset Display	Reset / Cancel	

Function descriptions

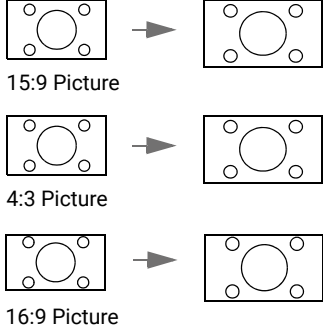
Menu	Descriptions
Aspect Ratio	<p>There are several options to set the image's aspect ratio depending on your input signal source.</p> <ul style="list-style-type: none"> • Auto Scales an image proportionally to fit the projector's native resolution in its horizontal or vertical width. • 4:3 Scales an image so that it is displayed in the center of the screen with a 4:3 aspect ratio. • 16:9 Scales an image so that it is displayed in the center of the screen with a 16:9 aspect ratio.  <p style="text-align: right;">15:9 Picture 4:3 Picture 16:9 Picture</p>
Auto Source Search	<p>Allows the projector to automatically search for a signal.</p>
Source Rename	<p>You can rename the current input source to whatever you want. See "Renaming the source" on page 47.</p>
3D	<p>This projector supports playing three-dimensional (3D) content transferred through your 3D-compatible video devices and contents, such as PlayStation consoles (with 3D game discs), 3D Blu-ray players (with 3D Blu-ray discs), and so on. After you have connected the 3D video devices to the projector, wear the BenQ 3D glasses and make sure the power is on to view 3D contents.</p> <p>When watching 3D contents:</p> <ul style="list-style-type: none"> • The image may seem misplaced; however, this is not a product malfunction. • Take appropriate breaks when watching 3D contents. • Stop watching 3D contents if you feel fatigue or discomfort. • Keep a distance from the screen of about three times the effective height of the screen. • Children and people with a history of oversensitivity to light, heart problems, or any other existing medical conditions should be refrained from watching 3D contents. • The image may seem reddish, greenish, or bluish without wearing 3D glasses. However, you will not notice any color bias when watching 3D contents with 3D glasses.

Menu	Descriptions
3D (Continued)	<ul style="list-style-type: none"> • The 4K source will not be displayed. When source is Media Reader, 3D mode is not supported. • 3D Mode The default setting is Auto and the projector automatically chooses an appropriate 3D format when detecting 3D contents. If the projector cannot recognize the 3D format, press OK to choose a 3D mode from among Frame Sequential, Frame Packing, Top-Bottom, and Side by Side. When this function is enabled: <ul style="list-style-type: none"> • The brightness level of the projected image decreases. • The Picture Mode cannot be adjusted. • The 2D Keystone can only be adjusted within limited degrees. • 3D Sync Invert When your 3D image is distorted, enable this function to switch between the image for the left eye and the right eye for more comfortable 3D viewing experience.
HDMI Settings	<ul style="list-style-type: none"> • HDMI Format Selects a suitable RGB color range to correct the color accuracy. <ul style="list-style-type: none"> • Auto: Automatically selects a suitable color range for the incoming HDMI signal. • Limited: Utilizes the Limited range RGB 16-235. • Full: Utilizes the Full range RGB 0-255. • HDMI Equalizer Sets a suitable value to maintain the HDMI picture quality in long distance data transmission. • HDMI EDID Switches between Enhanced for HDMI 2.0 EDID and Standard for HDMI 1.4 EDID. Selecting Standard which supports up to 1080p 60Hz may solve abnormal display issues with some old players. • Electronics Control When connecting to HDMI CEC compatible devices to the projector with HDMI cables, these devices can be controlled through the projector. CEC function only support power on from device / power off from projector / power on ARC device / mute, volume up, volume down ARC device. • Power On Link / Power Off Link When you connect an HDMI CEC-compatible device to your projector with an HDMI cable, you can set the behavior of powering on/off between the device and the projector. <ul style="list-style-type: none"> • Power On Link > From Device: When the connected device is turned on, the projector will be activated, too. • Power Off Link > From Projector: When the projector is turned off, the connected device will be shut down, too.
Reset Display	Returns all the settings in the Display main menu to the factory default values.

Main menu: **Installation**

Structure

Menu	Options	
Projector Position	Front / Front Ceiling / Rear / Rear Ceiling	
2D Keystone	H / V	
Corner Fit	Top Left / Top Right / Bottom Left / Bottom Right	0 ~ 100
Screen Fit	OK	
Object Avoidance	OK	
Auto Focus	Real Time Adjustment	Off / On
	Auto Foucs Sensitivity	Normal / High
	Manual Focus	
Ambient Light Sensor	Off / On	
Test Pattern	Off / On	
High Altitude Mode	Off / On	

Function descriptions

Menu	Descriptions
Projector Position	The projector can be installed on a ceiling or behind a screen, or with one or more mirrors. See "Choosing a location" on page 21 for details.
2D Keystone	See "2D Keystone" on page 33 for details.
Corner Fit	Manually adjust the image by corner adjustment. See "Corner Fit" on page 34 for details.
Screen Fit	Auto alignment image to fit the screen size. See "Screen Fit" on page 35 for details.
Object Avoidance	Auto detect and avoid object then project the image on empty(non-object). See "Object Avoidance" on page 36 for details.
Auto Focus	Sharpen the image quality. See "Fitting the image to your screen" on page 33 for details. <ul style="list-style-type: none"> • Real Time Adjustment Allows the projector to adjust the focus settings in real time. • Auto Foucs Sensitivity Allows you to set the level of sensibility the Real Time Adjustment function uses to make the adjustments. • Manual Focus Allows you to manually adjust the focus for the projected image.

Menu	Descriptions
Ambient Light Sensor	To actively detects ambient light conditions in viewing environment and automatically adjusts balanced visual brightness for maximum comfort. Available under any Picture Mode , except for Brightness mode and 3D .
Test Pattern	Adjusts the image size and focus and check that the projected image is free from distortion.
High Altitude Mode	<p>We recommend you use the High Altitude Mode when your environment is between 1500 m–3000 m above sea level, and ambient temperature is between 0°C–30°C.</p> <p>Operation under High Altitude Mode may cause a higher decibel operating noise level because of increased fan speed necessary to improve overall system cooling and performance.</p> <p>If you use this projector under other extreme conditions excluding the above, it may display auto shut-down symptoms, which is designed to protect your projector from over-heating. In cases like this, you should switch to High Altitude Mode to solve these symptoms. However, this is not to state that this projector can operate under any and all harsh or extreme conditions.</p> <p> Do not use the High Altitude Mode if your altitude is between 0 m and 1499 m and ambient temperature is between 0°C and 35°C. The projector will be over cooled, if you turn the mode on under such a condition.</p>

Main menu: **System**

Structure

Menu	Options	
Language	English / Français / Deutsch / Italiano / Español / Português / 繁體中文 / 日本語 / 한국어 / العربية / हिन्दी / Indonesian	
Menu Settings	Menu Type	Basic / Advanced
	Menu Display Time	5 sec / 10 sec / 20 sec / 30 sec / Always
	Menu Position	Center / Top Left / Top Right / Bottom Right / Bottom Left
Color Calibration	Auto Color Calibration	Off / Auto
	Reset Color Calibration	Reset / Cancel
Light Source Information	Light Source Usage Time	
	Normal Mode	
	ECO Mode	
	SmartEco Mode	
	Equivalent Light Hours	
Operation Settings	Reminder message	Off / On
	Power On/Off Settings	Direct Power On / Auto Power Off

Menu	Options
Factory Default	Reset / Cancel
Reset System	Reset / Cancel

Function descriptions

Menu	Descriptions
Language	Sets the language for the On-Screen Display (OSD) menus.
Menu Settings	<ul style="list-style-type: none"> • Menu Type Sets the OSD menu type according to your needs. • Menu Display Time Sets the length of time the OSD will remain active after your last key press. • Menu Position Sets the On-Screen Display (OSD) menu position.
Color Calibration	<ul style="list-style-type: none"> • Auto Color Calibration Automatically keeps out-of-box color consistency of the projector. • Reset Color Calibration Apply color table of factory default for projector.
Light Source Information	<ul style="list-style-type: none"> • Light Source Usage Time Light hours used under Normal Mode, ECO Mode, SmartEco Mode. • Equivalent Light Hours For details about how to calculate the hours, see "Light source information" on page 67.
Operation Settings	<ul style="list-style-type: none"> • Reminder Message Sets the reminder messages on or off. • Power On/Off Settings: <ul style="list-style-type: none"> • Direct Power On: Allows the projector to turn on automatically once the power is fed through the power cord. • Auto Power Off: Allows the projector to turn off automatically if no input signal is detected after a set period of time to prevent unnecessary waste of light source life.
Factory Default	<p>Returns all settings to the factory preset values.</p>  The following settings will still remain: All of the menu items in Installation menu, Light Source Information , Security Settings .

Menu	Descriptions
Reset System	Returns all the settings in the System main menu to the factory default values.  The following settings will still remain: Light Source Information, Security Settings.

Main menu: **Information**

Structure and function descriptions

Menu	Descriptions
Detected Resolution	Shows the native resolution of the input signal.
Source	Shows the current signal source.
Picture Mode	Shows the selected mode in the Picture menu.
Light Source Mode	Shows the used light source mode.
3D Format	Displays the current 3D mode. 3D Format is only available when 3D is enabled.
Color System	Shows the input system format.
Dynamic Range	Shows the picture dynamic range, e.g. SDR, HDR10, HLG, etc.
Light Source Usage Time	Shows the number of hours the light has been used.
Firmware Version	Shows the firmware version of your projector.
Service Code	Shows the projector's serial number.

Navigating the **Basic** menu

Menu(Ref. Page)	Options
Picture Mode (53)	Bright / Living Room / Game / Sports / Cinema / 3D / HDR10 / HLG / User
Contrast (54)	0 ~100
Brightness (54)	0 ~100
Light Source Mode (56)	Normal / ECO / SmartEco
Sound Mode (57)	Cinema / Music / Game / Sports / User
2D Keystone (61)	H / V
Installation (61)	Detected Resolution
	Source
	Picture Mode
	Light Source Mode
	3D Format
	Color System
	Dynamic Range
	Light Source Usage Time
	Firmware Version
Service Code	
Menu Type (62)	Basic / Advanced

Maintenance

Care of the projector

Your projector needs little maintenance. The only thing you have to do on a regular basis is keep the lens clean.

Never remove any parts of the projector. Contact your dealer or local customer service center if the projector fails to operate as expected.

Cleaning the lens

Clean the lens whenever you notice dirt or dust on the surface. Please be sure to turn off the projector and let it cool down completely before cleaning the lens.

- Use a canister of compressed air to remove dust.
- If there is dirt or smears, use lens-cleaning paper or moisten a soft cloth with lens cleaner and gently wipe the lens surface.
- Never use any type of abrasive pad, alkaline/acid cleaner, scouring powder, or volatile solvent, such as alcohol, benzene, thinner or insecticide. Using such materials or maintaining prolonged contact with rubber or vinyl materials may result in damage to the projector surface and cabinet material.



Never use wax, alcohol, benzene, thinner or other chemical detergents. These can damage the case.

Storing the projector

If you need to store the projector for an extended time, please follow the instructions below:

- Make sure the temperature and humidity of the storage area are within the recommended range for the projector. Please refer to ["Specifications" on page 71](#) or consult your dealer about the range.
- Retract the adjuster feet.
- Remove the battery from the remote control.
- Pack the projector in its original packing or equivalent.

Transporting the projector

It is recommended that you ship the projector with its original packing or equivalent.

Light source information

Getting to know the light hour

When the projector is in operation, the duration (in hours) of light source usage is automatically calculated by the built-in timer. The method of calculating the equivalent light hour is as follows:

1. Light Usage Time = (x+y+z+a) hours, if

Time used in **Normal** mode = x hours

Time used in **ECO** mode = y hours

Time used in **SmartEco** mode = z hours

2. Equivalent Light Hour = α hours

$$\alpha = \frac{A'}{X} \times x + \frac{A'}{Y} \times y + \frac{A'}{Z} \times z, \text{ if}$$

X= light source life spec of **Normal** mode

Y= light source spec of **ECO** mode

Z= light source spec of **SmartEco** mode

A' is the longest light life spec among X, Y, Z.



For time used in each light source mode shown in OSD menu:

- Time used is accumulated and rounded down to an integer in hours.
- When time used is less than 1 hour, it shows 0 hours.



When you calculate Equivalent Light Hours manually, it will probably have deviation from the value shown in OSD menu since projector system calculates time used for each light source mode in "Minutes" then rounds down to an integer in hours shown in OSD.

To obtain the light source information:

Go to **Advanced Menu - System > Light Source Information** and press **OK**. The **Light Source Information** page appears.

You can also get the light hour information on the **Information** menu.

Extending LED life

The LED headlight includes a bulb which features a light-source life far beyond traditional bulbs, yet it is still a consumable item. To keep the LED life as long as possible, you can change the following settings via the settings menu.

- Setting the light source mode

Go to **Picture > Advanced Color Settings > Light Source Mode** and select a suitable light source mode from among the provided modes.

Set the projector to **ECO** or **SmartEco** mode to extend the LED life.

Light source mode	Description
Normal	Provides full light source brightness.

Light source mode	Description
ECO	Lowers brightness to extend the light source life and decreases the fan noise.
SmartEco	Adjusts the light source power automatically depending on the content brightness level while optimizing display quality.

- Auto power off

This function allows the projector to turn off automatically if no input signal is detected after a set period of time to prevent unnecessary waste of light source life.

To set auto power off, go to **System > Operation Settings > Power On/Off Settings**, and select **Auto Power off**.

Trouble shooting

 The projector does not turn on.

Cause	Remedy
There is no power from the power cord.	Plug the power cord into the AC power jack on the projector, and plug the power cord into the power outlet. If the power outlet has a switch, make sure that it is switched on.
Attempting to turn the projector on again during the cooling process.	Wait until the cooling down process has completed.

 No picture.

Cause	Remedy
The video source is not turned on or connected correctly.	Turn the video source on and check that the signal cable is connected correctly.
The projector is not correctly connected to the input signal device.	Check the connection.
The input signal has not been correctly selected.	Select the correct input signal with the  key.

 Blurred image

Cause	Remedy
The projection lens is not correctly focused.	Adjust the focus of the lens using the focus ring.
The projector and the screen are not aligned properly.	Adjust the projection angle and direction as well as the height of the projector if necessary

 Remote control does not work.

Cause	Remedy
The batteries are out of power.	Replace both of the batteries with new ones.
There is an obstacle between the remote control and the projector.	Remove the obstacle.

Cause	Remedy
You are too far away from the projector.	Stand within 8 meters (26 feet) of the projector.



Screen brightness adjustment.

Cause	Remedy
The screen is not as bright as expected.	The screen brightness is changed by the light source mode. Check the light source mode from Picture > Advanced Color Settings > Light Source Mode . Choose Normal to have the full light source brightness. Note that this option also consumes more power than other options.

Specifications

Projector specifications

Item	Descriptions	
Projection System	DLP	
DMD Type	0.47"	
Native Resolution	4K	
Brightness	1500 ANSI Lumens	
Contrast Ratio	100,000:1	
Display Color	30 Bits (1.07 Billion Colors)	
Aspect Ratio	16:9	
Light Source	Osram LED	
Light Source Life(1)	20,000 (Normal/SmartEco)/30,000 hours (ECO)	
Throw Ratio	1.0~1.3	
Zoom Ratio	1.3X	
Keystone Correction	2D Keystone	
Projection Offset	100% ± 5%	
Projection Size	40"~200"(Maximum)	
Interface	<ul style="list-style-type: none"> • 3.5mm Audio Out x 1 • SPDIF x 1 • Type-A (USB 2.0) x 1: Media reader/drive,Firmware download (5VDC/1.0A) • Type-A (USB 2.0) x 1: Media reader/Power supply (5VDC/2.0A) • HDMI-1 version: 2.0b x1 • HDMI-2 version: 2.0b x1 	
Power	DC Supply	
	Frequency	AC100 to 240V 50/60HZ 1.7A
	Power Consumption	180W (Max) /0.5W (Standby)
Built-in Speaker	5W x 4	
Resolution Support	VGA (640 x 480) to 4K UHD (3840 x 2160)	
Horizontal Frequency	15 to 135 KHz	
Vertical Scan Rate	23 to 120 Hz	
Operating Temperature	0 to 40 °C	

Item	Descriptions
Storage Temperature	-20 to 60 °C at sea level
Operating Relative Humidity/Storage Humidity	10~90% (without condensation)
Operating altitude	0–1499 m above sea level at 0°C–35°C 1500–3000 m above sea level at 0°C–30°C (with High Altitude Mode on)
Storage altitude	30°C@ 0~12,200 m above sea level



- LED life results will vary depending on environmental conditions and usage.
- The performance of WLAN and Bluetooth might be disturbed by distance and obstacles.

Timing chart

Resolution	Resolution	Horizontal frequency (KHz)	Vertical frequency (Hz)	Dot Clock Frequency (MHz)	3D Field Sequential	3D over-under	3D side-by-side
640 x 480	VGA_60	59.940	31.469	25.175		0	0
	VGA_72	72.809	37.861	31.500			
	VGA_75	75.000	37.500	31.500			
	VGA_85	85.008	43.269	36.000			
720 x 400	720 x 400_70	70.087	31.469	28.3221			
800 x 600	SVGA_60	60.317	37.879	40.000		0	0
	SVGA_72	72.188	48.077	50.000			
	SVGA_75	75.000	46.875	49.500			
	SVGA_85	85.061	53.674	56.250			
	SVGA_120 (Reduce Blanking)	119.854	77.425	83.000			
1024 x 768	XGA_60	60.004	48.363	65.000		0	0
	XGA_70	70.069	56.476	75.000			
	XGA_75	75.029	60.023	78.750			
	XGA_85	84.997	68.667	94.500			
	XGA_120 (Reduce Blanking)	119.989	97.551	115.500			
1152 x 864	1152 x 864_75	75.00	67.500	108.000			
1024 x 576	BenQ Notebook Timing	60.00	35.820	46.996			
1024 x 600	BenQ Notebook Timing	64.995	41.467	51.419			
1280 x 720	1280 x 720_60	60	45.000	74.250		Δ	Δ
1280 x 768	1280 x 768_60	59.870	47.776	79.5		0	0
1280 x 800	WXGA_60	59.810	49.702	83.500		0	0
	WXGA_75	74.934	62.795	106.500			
	WXGA_85	84.880	71.554	122.500			
	WXGA_120 (Reduce Blanking)	119.909	101.563	146.25			

Resolution	Resolution	Horizontal frequency (KHz)	Vertical frequency (Hz)	Dot Clock Frequency (MHz)	3D Field Sequential	3D over-under	3D side-by-side
1280 x 1024	SXGA_60	60.020	63.981	108.000		0	0
	SXGA_75	75.025	79.976	135.000			
	SXGA_85	85.024	91.146	157.500			
1280 x 960	1280 x 960_60	60.000	60.000	108		0	0
	1280 x 960_85	85.002	85.938	148.500			
1360 x 768	1360 x 768_60	60.015	47.712	85.500		0	0
1440 x 900	WXGA+_60	59.887	55.935	106.500		0	0
1400 x 1050	SXGA+_60	59.978	65.317	121.750		0	0
1600 x 1200	UXGA	60.000	75.000	162.000		0	0
1680 x 1050	1680x1050_60	59.954	65.290	146.250		0	0
640 x 480 @ 67Hz	MAC13	66.667	35.000	30.240			
832 x 624 @ 75Hz	MAC16	74.546	49.722	57.280			
1024 x 768 @ 75Hz	MAC19	75.020	60.241	80.000			
1152 x 870 @ 75Hz	MAC21	75.06	68.68	100.00			
1920 x 1080 @ 60Hz	1920 x 1080_60 (CEA-861)	60	67.5	148.5	0	Δ	Δ
1920 x 1200 @ 60Hz	1920 x 1200_60 (Reduce Blanking)	59.95	74.038	154		0	0
1920 x 1080 @ 120Hz	1920 x 1080_120	120.000	135.000	297	0		
3840 x 2160	3840 x 2160_30 For 4K2K model	30	67.5	297			
3840 x 2160	3840 x 2160_60 For 4K2K model	60	135	594			

Δ: support auto detect 3D and manually set 3D format (base on 3D inforframe)

0 : support manually set 3D format

Video timings

Resolution	Resolution	Horizontal frequency (KHz)	Vertical frequency (Hz)	Dot Clock Frequency (MHz)	3D Field Sequential	3D frame packing	3D over-under	3D side-by-side
480i	720(1440) x 480	15.73	59.94	27				
480p	720 x 480	31.47	59.94	27				
576i	720(1440) x 576	15.63	50	27				
576p	720 x 576	31.25	50	27				
720/50p	1280 x 720	37.5	50	74.25		Δ	Δ	Δ
720/60p	1280 x 720	45.00	60	74.25		Δ	Δ	Δ
1080/24P	1920 x 1080	27	24	74.25		Δ	Δ	Δ
1080/25P	1920 x 1080	28.13	25	74.25				
1080/30P	1920 x 1080	33.75	30	74.25				
1080/50i	1920 x 1080	28.13	50	74.25				Δ
1080/60i	1920 x 1080	33.75	60	74.25				Δ
1080/50P	1920 x 1080	56.25	50	148.5			Δ	Δ
1080/60P	1920 x 1080	67.5	60	148.5	O		Δ	Δ
1080/120p	1920 x 1080	135	120	297	O			
2160/24P	3840 x 2160	54	24	297				
2160/25P	3840 x 2160	56.25	25	297				
2160/30P	3840 x 2160	67.5	30	297				
2160/50P	3840 x 2160	112.5	50	594				
2160/60P	3840 x 2160	135	60	594				

Δ: support auto detect 3D and manually set 3D format (base on 3D inforframe)

O: support manually set 3D format

Supported file formats

Items	File Extension
Music	MP3(.mp3) MP2(.mp2) M4A(.m4a) WAV(.wav)
Video	AVI(.avi) MOV(.mov) MPEG program stream (.mpg, .mp4) 3GP(.3gp, 3g2) ASF(.asf) WMV(.wmv) MKV(.mkv) VOB(.vob) DAT(.dat) TS(.ts) FLV(.flv)
Photo	JPG/JPEG BMP PNG

Copyright & disclaimer

Copyright

Copyright © 2022 by BenQ Corporation. All rights reserved. No part of this publication may be reproduced, transmitted, transcribed, stored in a retrieval system or translated into any language or computer language, in any form or by any means, electronic, mechanical, magnetic, optical, chemical, manual or otherwise, without the prior written permission of BenQ Corporation.

All other logos, products, or company names mentioned in this manual may be the registered trademarks or copyrights of their respective companies, and are used for informational purposes only.

Android™ is a trademark of Google LLC.

The Bluetooth® word mark and logos are registered trademarks owned by Bluetooth SIG, Inc. and any use of such marks by BenQ Corporation is under license.

iOS is a trademark or registered trademark of Cisco in the U.S. and other countries and is used under license.

macOS® is a trademark of Apple Inc., registered in the U.S. and other countries.

Disclaimer

BenQ Corporation makes no representations or warranties, either expressed or implied, with respect to the contents hereof and specifically disclaims any warranties, merchantability or fitness for any particular purpose. Further, BenQ Corporation reserves the right to revise this publication and to make changes from time to time in the contents hereof without obligation of BenQ Corporation to notify any person of such revision or changes. This user manual aims to provide the most updated and accurate information to customers, and thus all contents may be modified from time to time without prior notice. Please visit <http://www.benq.com> for the latest version of this manual.

Warranty

BenQ warrants this product against any defects in material and workmanship, under normal usage and storage.

Proof of purchase date will be required with any warranty claim. In the event this product is found to be defective within the warranty period, BenQ's only obligation and your exclusive remedy shall be replacement of any defective parts (labor included). To obtain warranty service, immediately notify the dealer from which you purchased the product of any defects.

Important: The above warranty shall be void if the customer fails to operate the product in accordance with BenQ's written instructions, especially the ambient humidity must be in-between 10% and 90%, temperature in-between 0°C and 40°C, altitude lower than 2000 meters, and avoiding to operate the projector in a dusty environment. This warranty gives you specific legal rights, and you may have other rights which vary from country to country.

For other information, please visit www.BenQ.com.

Statement regarding hyperlinks and third-party websites

BenQ is not responsible for the content of the websites or of similar resources, which are maintained and controlled by third parties, that may be linked from this product. Providing links to those websites or to similar resources does not mean that BenQ makes any warranty or representation to their content by expression or by implication.

Any third party content or service preinstalled in this product is provided "as is". BenQ does not, by expression or by implication, make any warrant to the content or to the services provided by third parties. BenQ does not warrant or guarantee that the content or services provided by third parties are accurate, effective, most up-to-date, legal, or complete. Under no circumstances shall BenQ be liable for the content or services provided by third parties including their negligence.

Services provided by third parties may be terminated temporarily or permanently. BenQ does not warrant or guarantee that any content or services provided by third parties are in good condition at any time, and is not liable for the termination of the said content and services.

In addition, BenQ is not involved in any transactions you conduct in the websites or similar resources maintained by third parties.

You should contact the content or service providers for any questions, concerns, or disputes.



BenQ.com