



Digital Projector

User Manual

Installation Projector | LU950 / LU951 / LU951ST

V 1.01

Warranty and Copyright information

Limited warranty

BenQ warrants this product against any defects in material and workmanship, under normal usage and storage.

Proof of purchase date will be required with any warranty claim. In the event this product is found to be defective within the warranty period, BenQ's only obligation and your exclusive remedy shall be replacement of any defective parts (labor included). To obtain warranty service, immediately notify the dealer from which you purchased the product of any defects.

Important: The above warranty shall be void if the customer fails to operate the product in accordance with BenQ's written instructions, especially the ambient humidity must be in-between 10% and 90%, temperature in-between 0°C and 40°C, altitude lower than 3000 m (used with High Altitude Mode), and avoiding to operate the projector in a dusty environment. This warranty gives you specific legal rights, and you may have other rights which vary from country to country.

For other information, please visit www.BenQ.com.

Copyright

Copyright © 2018 by BenQ Corporation. All rights reserved. No part of this publication may be reproduced, transmitted, transcribed, stored in a retrieval system or translated into any language or computer language, in any form or by any means, electronic, mechanical, magnetic, optical, chemical, manual or otherwise, without the prior written permission of BenQ Corporation.

Disclaimer

BenQ Corporation makes no representations or warranties, either expressed or implied, with respect to the contents hereof and specifically disclaims any warranties, merchantability or fitness for any particular purpose. Further, BenQ Corporation reserves the right to revise this publication and to make changes from time to time in the contents hereof without obligation to notify any person of such revision or changes.

*DLP, Digital Micromirror Device and DMD are trademarks of Texas Instruments. Others are copyrights of their respective companies or organizations.

Patents

Please go to <http://patmarking.benq.com/> for the details on BenQ projector patent coverage.

Table of Contents

| | |
|---|-----------|
| Warranty and Copyright information | 2 |
| Important safety instructions | 4 |
| Introduction | 6 |
| Shipping contents | 6 |
| Projector exterior view | 7 |
| Control Panel | 8 |
| Control terminals | 9 |
| Remote control | 10 |
| Installation | 13 |
| Choosing a location | 13 |
| Cooling notice | 13 |
| Obtaining a preferred projected image size..... | 14 |
| Mounting the projector..... | 16 |
| Adjusting the projector position..... | 17 |
| Adjusting the projected image..... | 18 |
| Connection | 20 |
| Operation | 22 |
| Starting up the projector | 22 |
| Using the menus | 22 |
| Securing the projector | 24 |
| Switching input signal | 25 |
| Shutting down the projector | 26 |
| Menu operation | 27 |
| Basic menu | 27 |
| Advanced menu | 29 |
| System | 37 |
| INFORMATION menu | 39 |
| Maintenance | 40 |
| Care of the projector | 40 |
| Light source information | 41 |
| LED Indicators..... | 43 |
| Troubleshooting | 44 |
| Specifications | 45 |
| Projector specifications | 45 |
| Dimensions | 46 |
| Timing chart..... | 47 |
| RS232 command..... | 52 |

Important safety instructions

Your projector is designed and tested to meet the latest standards for safety of information technology equipment. However, to ensure safe use of this product, it is important that you follow the instructions mentioned in the user manual / installation guide and marked on the product.

1. **Please read the user manual / installation guide before you operate your projector.** Save it for future reference.
2. **Do not look straight at the projector lens during operation.** The intense light beam may damage your eyes.
3. **Refer servicing to qualified service personnel.**
4. **Always open the lens shutter (if any) or remove the lens cap (if any) when the projector light source is on.**
5. The light source becomes extremely hot during operation.
6. In some countries, the line voltage is NOT stable. This projector is designed to operate safely within a mains voltage between 100 to 240 volts AC, but could fail if power cuts or surges of ± 10 volts occur. **In areas where the mains voltage may fluctuate or cut out, it is recommended that you connect your projector through a power stabilizer, surge protector or uninterruptible power supply (UPS).**
7. Do not block the projection lens with any objects when the projector is under operation as this could cause the objects to become heated and deformed or even cause a fire. To temporarily turn off the light source, use the blank function.
8. Do not operate light sources beyond the rated light source life.
9. Do not place this product on an unstable cart, stand, or table. The product may fall, sustaining serious damage.
10. Do not attempt to disassemble this projector. There are dangerous high voltages inside which may cause death if you should come into contact with live parts.

Under no circumstances should you ever undo or remove any other covers. Refer servicing only to suitably qualified professional service personnel.

11. Do not block the ventilation holes.
 - Do not place this projector on a blanket, bedding or any other soft surface.
 - Do not cover this projector with a cloth or any other item.
 - Do not place inflammables near the projector.If the ventilation holes are seriously obstructed, overheating inside the projector may result in a fire.
12. Do not stand the projector on end vertically. Doing so may cause the projector to fall over, causing injury or resulting in damage to the projector.
13. Do not step on the projector or place any objects upon it. Besides probable physical damage to the projector, doing so may result in accidents and possible injury.
14. When the projector is under operation, you may sense some heated air and odor from its ventilation grill. It is a normal phenomenon and not a product defect.
15. Do not place liquids near or on the projector. Liquids spilled into the projector may cause it to fail. If the projector does become wet, disconnect it from the power supply's power outlet and call BenQ to have the projector serviced.
16. This apparatus must be earthed.
17. Do not place this projector in any of the following environments.

- Space that is poorly ventilated or confined. Allow at least 50 cm clearance from walls and free flow of air around the projector.
- Locations where temperatures may become excessively high, such as the inside of a car with all windows rolled up.
- Locations where excessive humidity, dust, or cigarette smoke may contaminate optical components, shorten the projector's life span and darken the image.
- Locations near fire alarms
- Locations with an ambient temperature above 40°C / 104°F
- Locations where the altitudes are higher than 3000 m (10000 feet).

Risk Group 2

1. According to the classification of photobiological safety of light sources and light source systems, this product is Risk Group 2, IEC 62471-5:2015.
2. Possibly hazardous optical radiation emitted from this product.
3. Do not stare at operating light source. May be harmful to the eyes.
4. As with any bright source, do not stare into the direct beam.



The projector's light source unit uses a laser.

Laser Caution

This product belongs to CLASS I laser product and complies with IEC 60825-1:2014.

LASER RADIATION, DO NOT STARE INTO BEAM, CLASS I LASER PRODUCT.

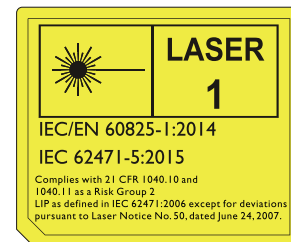

Introduction

Shipping contents

Carefully unpack and verify that you have all of the items shown below. If any of these items are missing, please contact your place of purchase.

Standard accessories

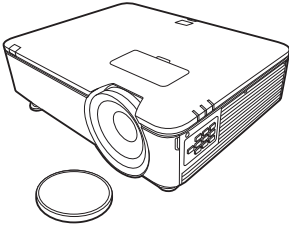

Projector



Remote control and batteries



Installation guide

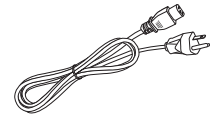

Power cord



The supplied accessories will be suitable for your region, and may differ from those illustrated.

Optional accessories

1. Ceiling mount CMG3
2. 3D glasses
3. InstaShow™ (WDC10)

Projector exterior view

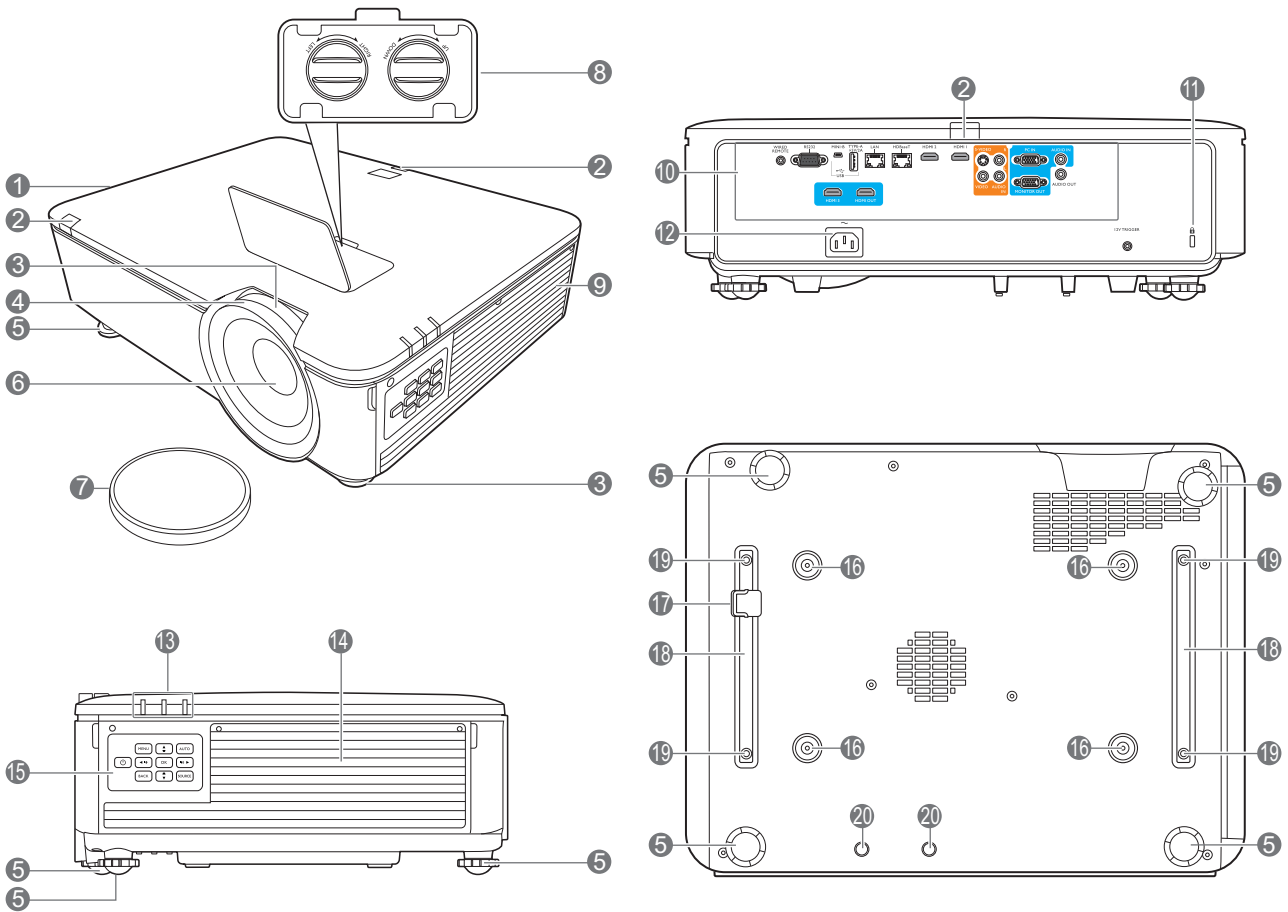

- | | |
|---|--|
| <ul style="list-style-type: none"> 1. Vent (heated air exhaust) 2. IR remote sensor 3. Zoom ring 4. Focus ring 5. Adjuster feet 6. Projection lens 7. Lens cover 8. Lens shift adjustment knobs (LEFT/RIGHT, UP/DOWN) 9. Vent (cool air intake) 10. Control terminals (See Control terminals on page 9.) 11. Kensington anti-theft lock slot | <ul style="list-style-type: none"> 12. AC power jack 13. POWER indicator light/TEMPerature warning light/LIGHT indicator light (See LED Indicators on page 43.) 14. Filter cover 15. External control panel (See Control Panel on page 8.) 16. Ceiling mount holes 17. Security bar 18. Projector holder 19. Third party mounting holes 20. InstaShow holes |
|---|--|

Control Panel

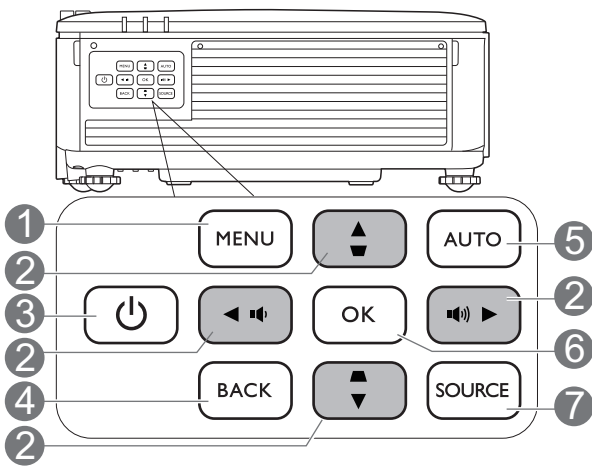

1. **MENU**
Turns on the On-Screen Display (OSD) menu.
2. **Arrow keys** (▲, ▼, ◀, ▶)
When the On-Screen Display (OSD) menu is activated, these keys are used as directional arrows to select the desired menu items and to make adjustments.
Keystone keys (▴, ▾)
Displays the keystone correction page.
Volume keys (🔇, 🔊, 🔊)
Decreases or increase the projector volume.
3. **POWER**
Toggles the projector between standby mode and on.
4. **BACK**
Goes back to previous OSD menu, exits and saves menu settings.
5. **AUTO**
Automatically determines the best picture timings for the displayed image when PC signal (analog RGB) is selected.
6. **OK**
Confirms the selected On-Screen Display (OSD) menu item.
7. **SOURCE**
Displays the source selection bar.



All the key presses described in this document are available on the remote control or projector.

Control terminals

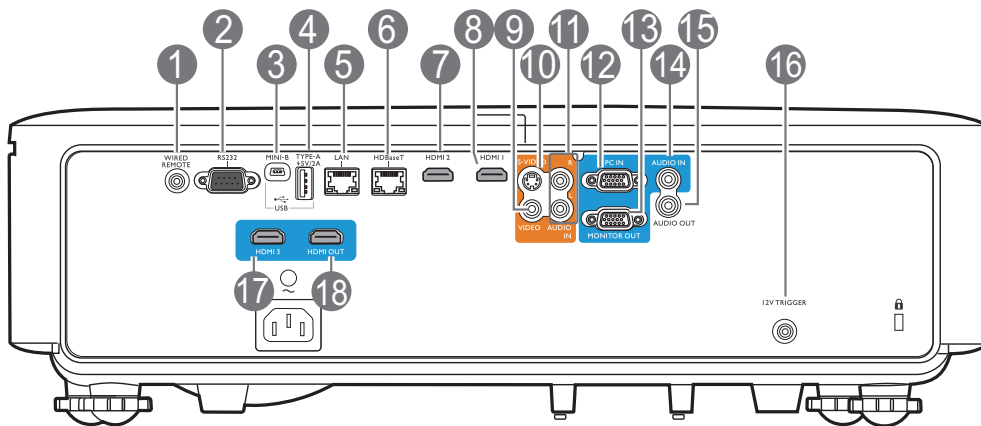

1. WIRED REMOTE

For connection to a wired remote control.

2. RS232

Standard 9-pin D-sub interface for connection to PC control system and projector maintenance.

3. USB MINI-B

For firmware upgrade only.

4. USB TYPE A

Support 5V/2A output.

5. LAN

For connection to RJ45 Cat5/Cat6 Ethernet cable to control the projector through a network.

6. HDBaseT

For connection to RJ45 Cat5/Cat6 cable to input uncompressed high-definition video (HD).

7. HDMI 2

Connection to HDMI source.

8. HDMI 1

Connection to HDMI source.

9. VIDEO

Connection to composite video source.

10. S-VIDEO

Connection to S-Video source.

11. AUDIO IN L/R

Connection to an audio input source via an audio or audio L/R cable.

12. PC IN

15-pin VGA port for connection to RGB source or PC.

13. MONITOR OUT

Connection to other display equipment for concurrent playback display. (Used with **PC IN** port.)

14. AUDIO IN

Connection to an audio input source via an audio cable. (Used with **PC IN** port.)

15. AUDIO OUT

Connection to a speaker or headset.

16. 12V TRIGGER

Trigger external devices such as an electric screen or light control, etc.

17. HDMI 3

Connection to HDMI source.

18. HDMI OUT

Connection to other display equipment for concurrent playback display. (Used with **HDMI 3** port.)

Remote control

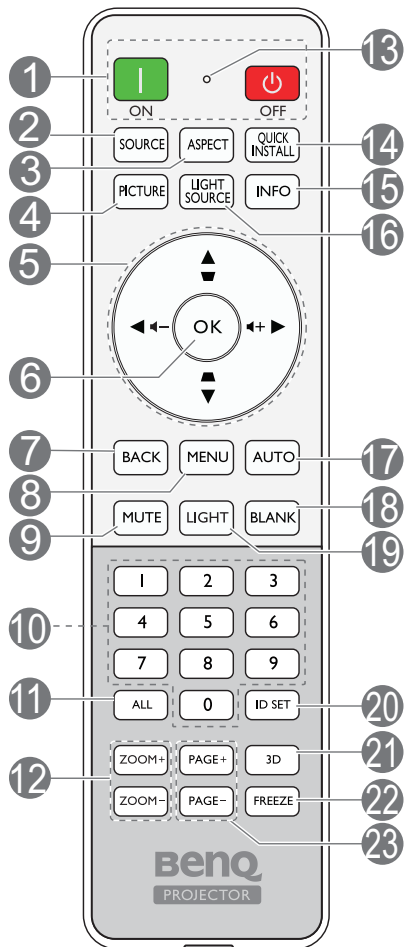

1. **ON/OFF**
Toggles the projector between standby mode and on.
2. **SOURCE**
Displays the source selection bar.
3. **ASPECT**
Selects the display aspect ratio.
4. **PICTURE**
Selects an available picture setup mode.
5. **Arrow keys** (▲, ▼, ◀, ▶)
When the On-Screen Display (OSD) menu is activated, these keys are used as directional arrows to select the desired menu items and to make adjustments.
6. **OK**
Confirms the selected On-Screen Display (OSD) menu item.
7. **BACK**
Goes back to previous OSD menu, exits and saves menu settings.
8. **MENU**
Turns on the On-Screen Display (OSD) menu.
9. **MUTE**
Toggles projector audio between on and off.
10. **Numeric buttons**
Enters numbers in network settings or when setting the remote control ID. Numeric buttons 1, 2, 3, 4 cannot be pressed when asked to enter password.
11. **ALL**
Press and hold **ID SET** until the ID setting indicator lights up. Press **ALL** to clear current ID setting of the remote control. The ID is cleared successfully when you see the ID setting indicator starts flickering and then blackout.
12. **ZOOM+/ZOOM-**
Magnifies or reduces the projected picture size.
13. **ID setting indicator**
14. **QUICK INSTALL**
Quickly selects several functions to adjust the projected image and displays the test pattern.
15. **INFO**
Displays the projector information.
16. **LIGHT SOURCE**
Selects a suitable light source power among the provided modes.
17. **AUTO**
Automatically determines the best picture timings for the displayed image.

18. BLANK

Used to hide the screen picture.



Do not block the projection lens from projecting as this could cause the blocking object to become heated and deformed or even cause a fire.

19. LIGHT

Turns on the remote control backlight for a few seconds. To keep the backlight on, press any other key while the backlight is on. Press the key again to turn the backlight off.

20. ID SET

Sets the code for this remote control. Press and hold **ID SET** until the ID setting indicator lights up. Enter the ID for the remote control (between 01~99). The remote control ID should be the same as the corresponding projector ID. The ID is saved successfully when you see the ID setting indicator starts flickering and then blackout.

21. 3D

Displays the **3D** menu.

22. FREEZE

Freezes the projected image.

23. PAGE+/PAGE-

No function.

Remote control effective range

The remote control must be held at an angle within 30 degrees perpendicular to the projector's IR remote control sensor(s) to function correctly. The distance between the remote control and the sensor(s) should not exceed 7 meters (~ 23 feet).

Make sure that there are no obstacles between the remote control and the IR sensor(s) on the projector that might obstruct the infra-red beam.

- Operating the projector from the front

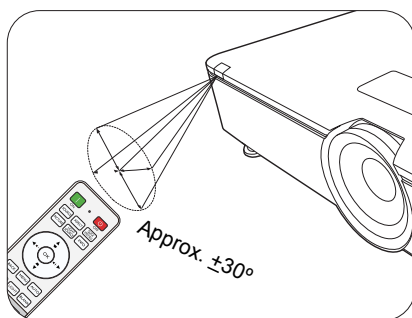

- Operating the projector from the rear

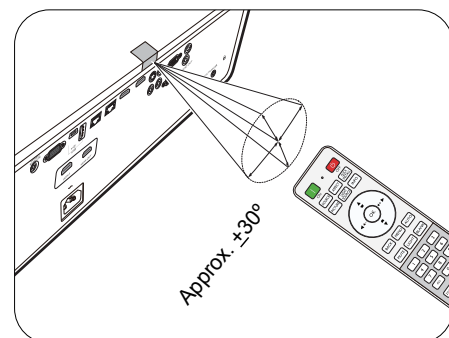

Replacing the remote control batteries

1. Press and slide off the battery cover, as illustrated.
2. Remove the old batteries (if applicable) and install two AAA batteries. Make sure that the positive and negative ends are positioned correctly, as illustrated.
3. Slide the battery cover in until it clicks into place.

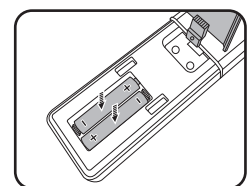
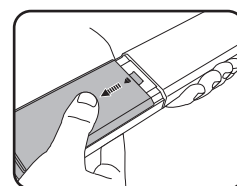



- Avoid leaving the remote control and batteries in an excessive heat or humid environment like the kitchen, bathroom, sauna, sunroom or in a closed car.
- Replace only with the same or equivalent type recommended by the battery manufacturer.
- Dispose of the used batteries according to the manufacturer's instructions and local environment regulations for your region.
- Never throw the batteries into a fire. There may be danger of an explosion.
- If the batteries are dead or if you will not be using the remote control for an extended period of time, remove the batteries to avoid damage to the remote control from possible battery leakage.

Installation

Choosing a location

Before choosing an installation location for your projector, take the following factors into consideration:

- Size and position of your screen
- Electrical outlet location
- Location and distance between the projector and the rest of your equipment

You can install your projector in the following ways: **Front Table, Front Ceiling, Rear Ceiling, Rear Table.** (See [Projector Installation on page 34.](#))

The projector can also be installed at following angles:

360-degree projection

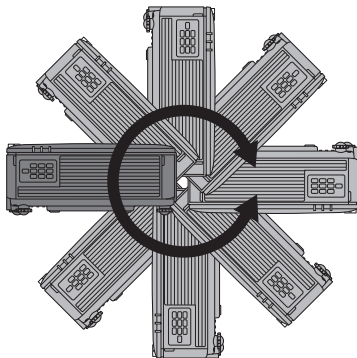

! Installation of the projector should be performed carefully. Incomplete or improper installation may cause the projector to fall, resulting in personal injury or property damage.

Cooling notice

Ventilation

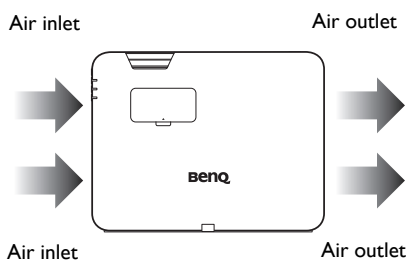

Caution for installation

For proper ventilation of the projector, make sure to leave some space around the projector as shown in the illustration below:

• Table

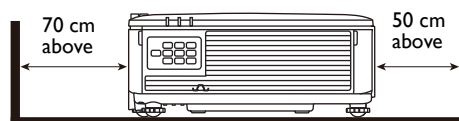

• Table

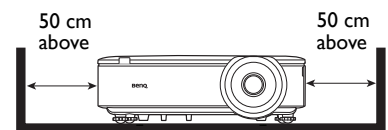

• Ceiling

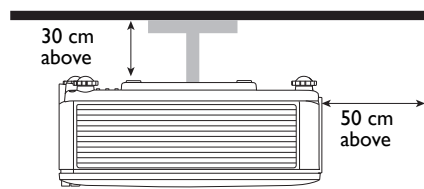

• Stacking

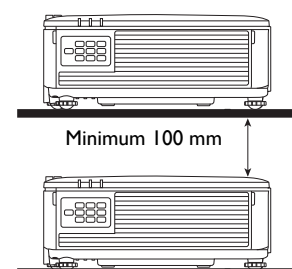

- Avoid using the projector in a poorly ventilated or confined space.
- The light source life may be affected if the projector is used tilted at an angle of more than ± 15 degrees.

Obtaining a preferred projected image size

The distance from the projector lens to the screen, the zoom setting, and the video format each factors in the projected image size.

Projection dimensions

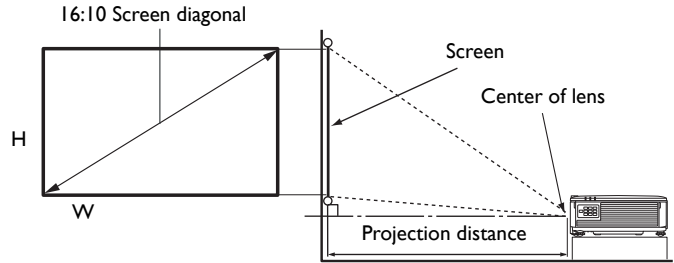

The screen aspect ratio is 16:10 and the projected picture is in a 16:10 aspect ratio

| Screen size | | | | Distance from screen (mm) | | |
|-------------|------|--------|--------|---------------------------|---------|---------------------------|
| Diagonal | | W (mm) | H (mm) | Min length (max. zoom) | Average | Max length (min. zoom) |
| Inch | mm | | | | | |
| 30 | 762 | 646 | 404 | 879 | 1144 | 1409 |
| 40 | 1016 | 862 | 538 | 1172 | 1525 | 1878 |
| 50 | 1270 | 1077 | 673 | 1465 | 1906 | 2348 |
| 60 | 1524 | 1292 | 808 | 1758 | 2287 | 2817 |
| 80 | 2032 | 1723 | 1077 | 2343 | 3050 | 3756 |
| 90 | 2286 | 1939 | 1212 | 2636 | 3431 | 4226 |
| 100 | 2540 | 2154 | 1346 | 2929 | 3812 | 4696 |
| 110 | 2794 | 2369 | 1481 | 3222 | 4194 | 5165 |
| 120 | 3048 | 2585 | 1615 | 3515 | 4575 | 5635 |
| 130 | 3302 | 2800 | 1750 | 3808 | 4956 | 6104 |
| 140 | 3556 | 3015 | 1885 | 4101 | 5337 | 6574 |
| 150 | 3810 | 3231 | 2019 | 4394 | 5719 | 7043 |
| 160 | 4064 | 3446 | 2154 | 4687 | 6100 | 7513 |
| 170 | 4318 | 3662 | 2289 | 4980 | 6481 | 7982 |
| 180 | 4572 | 3877 | 2423 | 5273 | 6862 | 8452 |
| 190 | 4826 | 4092 | 2558 | 5566 | 7244 | 8922 |
| 200 | 5080 | 4308 | 2692 | 5859 | 7625 | 9391 |
| 250 | 6350 | 5385 | 3365 | 7323 | 9531 | 11739 |
| 300 | 7620 | 6462 | 4039 | 8788 | 11437 | 14087 |

LU951ST

| Screen size | | | | Distance from screen (mm) | | |
|-------------|------|--------|--------|---------------------------|---------|-------------|
| Diagonal | | W (mm) | H (mm) | Min length | Average | Max length |
| Inch | mm | | | (max. zoom) | | (min. zoom) |
| 30 | 762 | 646 | 404 | 523 | 549 | 575 |
| 40 | 1016 | 862 | 538 | 698 | 732 | 767 |
| 50 | 1270 | 1077 | 673 | 872 | 915 | 958 |
| 60 | 1524 | 1292 | 808 | 1047 | 1098 | 1150 |
| 80 | 2032 | 1723 | 1077 | 1396 | 1465 | 1534 |
| 90 | 2286 | 1939 | 1212 | 1570 | 1648 | 1725 |
| 100 | 2540 | 2154 | 1346 | 1745 | 1831 | 1917 |
| 110 | 2794 | 2369 | 1481 | 1919 | 2014 | 2109 |
| 120 | 3048 | 2585 | 1615 | 2094 | 2197 | 2300 |
| 130 | 3302 | 2800 | 1750 | 2268 | 2380 | 2492 |
| 140 | 3556 | 3015 | 1885 | 2443 | 2563 | 2684 |
| 150 | 3810 | 3231 | 2019 | 2617 | 2746 | 2875 |
| 160 | 4064 | 3446 | 2154 | 2791 | 2929 | 3067 |
| 170 | 4318 | 3662 | 2289 | 2966 | 3112 | 3259 |
| 180 | 4572 | 3877 | 2423 | 3140 | 3295 | 3451 |
| 190 | 4826 | 4092 | 2558 | 3315 | 3479 | 3642 |
| 200 | 5080 | 4308 | 2692 | 3489 | 3662 | 3834 |
| 250 | 6350 | 5385 | 3365 | 4362 | 4577 | 4792 |
| 300 | 7620 | 6462 | 4039 | 5234 | 5492 | 5751 |



- To optimize your projection quality, we suggest you do the projection within non-gray area.

- All measurements are approximate and may vary from the actual sizes.

BenQ recommends that if you intend to permanently install the projector, you should physically test the projection size and distance using the actual projector in situ before you permanently install it, so as to make allowance for this projector's optical characteristics. This will help you determine the exact mounting position so that it best suits your installation location.



- Ceiling installation must be done by a qualified professional. Contact your dealer for more information. It is not recommended you install the projector yourself.

- Only use the projector on a solid, level surface. Serious injury and damage can occur if the projector is dropped.
- Do not use the projector in an environment where extreme temperature occurs. The projector must be used at temperatures between 32 degrees Fahrenheit (0 degrees Celsius) and 104 degrees Fahrenheit (40 degrees Celsius).
- Screen damage will occur if the projector is exposed to moisture, dust or smoke.
- Do not cover the vents on the projector. Proper ventilation is required to dissipate heat. Damage to the projector will occur if the vents are covered.

Mounting the projector

If you intend to mount your projector, we strongly recommend that you use a proper fitting BenQ projector mounting kit and that you ensure it is securely and safely installed.

If you use a non-BenQ brand projector mounting kit, there is a safety risk that the projector may fall down due to an improper attachment through the use of the wrong gauge or length screws.

Before mounting the projector

- Purchase a BenQ projector mounting kit from the place you purchased your BenQ projector.
- BenQ recommends that you also purchase a separate security cable and attach it securely to both the security bar on the projector and the base of the mounting bracket. This will perform the secondary role of restraining the projector should its attachment to the mounting bracket become loose.
- Ask your dealer to install the projector for you. Installing the projector on your own may cause it to fall and result in injury.
- Take necessary procedures to prevent the projector from falling off such as during an earthquake.
- The warranty doesn't cover any product damage caused by mounting the projector with a non-BenQ brand projector mounting kit.
- Consider the surrounding temperature where the projector is ceiling mounted. If a heater is used, the temperature around the ceiling may be higher than expected.
- Read the user manual for the mounting kit about the range of torque. Tightening with torque exceeding the recommended range may cause damage to the projector and subsequently falling off.
- Make sure the power outlet is at an accessible height so that you can easily shut down the projector.

Adjusting the projector position

Shifting the projection lens

The lens shift control provides flexibility for installing your projector. It allows the projector to be positioned off the center of the screen.

The lens shift is expressed as a percentage of the projected image height or width. You can turn the knobs on the projector to shift the projection lens in any direction within the allowable range depending on your desired image position.

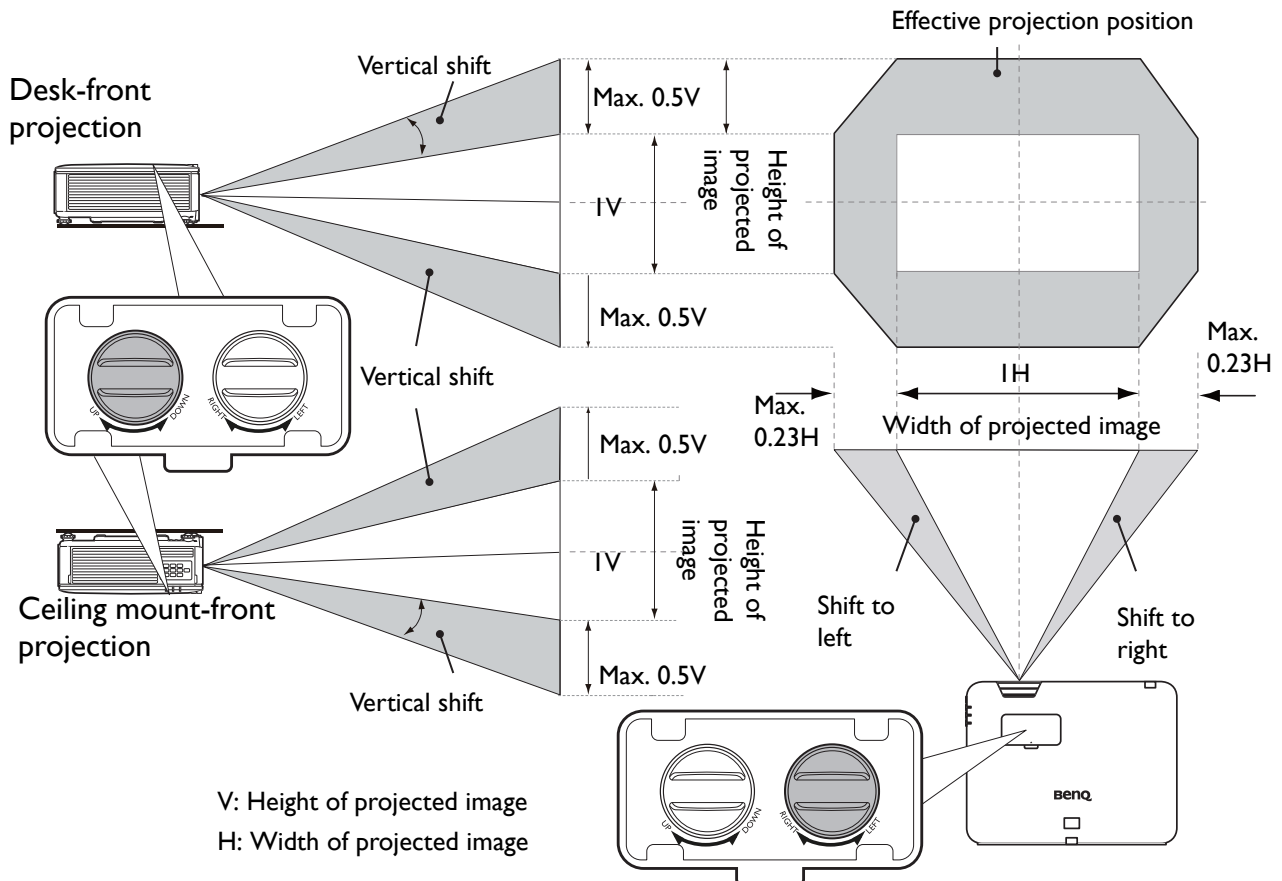

- Lens shift adjustment will not result in a degraded picture quality.
- Please stop turning the adjustment knob when you hear a clicking sound indicating that the knob has reached its limit. Over-turning the knob may cause damage.

Adjusting the projected image

Adjusting the projection angle

If the projector is not placed on a flat surface or the screen and the projector are not perpendicular to each other, the projected image becomes trapezoidal. You can screw the adjuster feet to fine-tune the horizontal angle.

To retract the feet, screw the adjuster feet in a reverse direction.

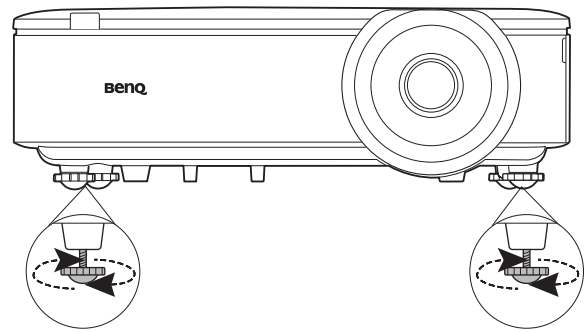

! Do not look into the lens while the light source is on. The strong light from the light source may cause damage to your eyes.

Fine-tuning the image size and clarity

1. Adjust the projected image to the size that you need using the zoom ring.
2. Sharpen the image by rotating the focus ring.

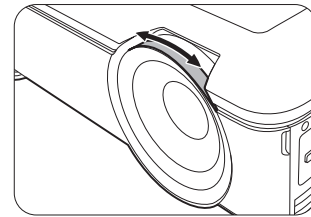
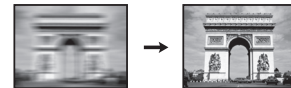
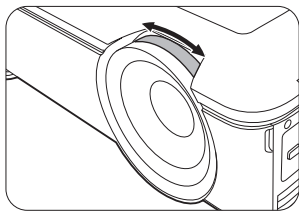

Correcting keystone

! This function is not available when there is no input signal. If you wish to use this function when there is no input signal, activate **Test Pattern** first.

Keystoning refers to the situation where the projected image becomes a trapezoid due to angled projection.

To correct this, you will need to manually correct it following these steps.

1. Do one of the following steps to display the keystone correction page.
 - Press **▲** / **▼** on the projector or remote control.
 - Press **QUICK INSTALL** on the remote control. Press **▼** to highlight **2D Keystone** and press **OK**.
 - Go to **Advanced Menu - Display > 2D Keystone** and press **OK**.
2. After the **2D Keystone** correction page displays. Press **▲** to correct keystone at the top of the image. Press **▼** to correct keystone at the bottom of the image. Press **◀** to correct keystone at the right side of the image. Press **▶** to correct keystone at the left side of the image.



3. When **2D Keystone** correction page displays, you can also do the following settings:

- Press **AUTO** to reset the keystone values.
- Press **▲/▼** to disable the auto vertical keystone function.

Adjusting Corner Fit



This function is not available when there is no input signal. If you wish to use this function when there is no input signal, activate **Test Pattern** first.

You can manually adjust four corners of the image by setting the horizontal and vertical values.

1. Do one of the following steps to display the corner fit correction page.
 - Press **QUICK INSTALL** on the remote control. Press **▼** to highlight **Corner Fit** and press **OK**.
 - Go to **Advanced Menu - Display > Corner Fit** and press **OK**.
2. Press **▲/▼/◀/▶** to select one corner and press **OK**.
3. Press **▲/▼** to adjust vertical values.
4. Press **◀/▶** to adjust horizontal values.

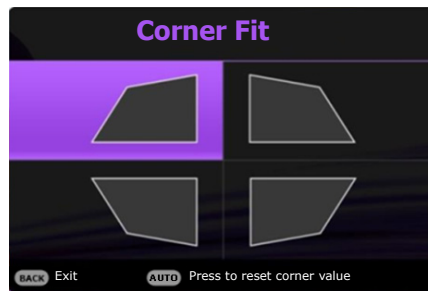

Connection

Before connecting, carefully read the operating instructions for connecting the external device. When connecting a signal source to the projector, be sure to:

1. Turn all equipment off before making any connections.
2. Use the correct signal cables for each source.
3. Ensure the cables are firmly inserted.

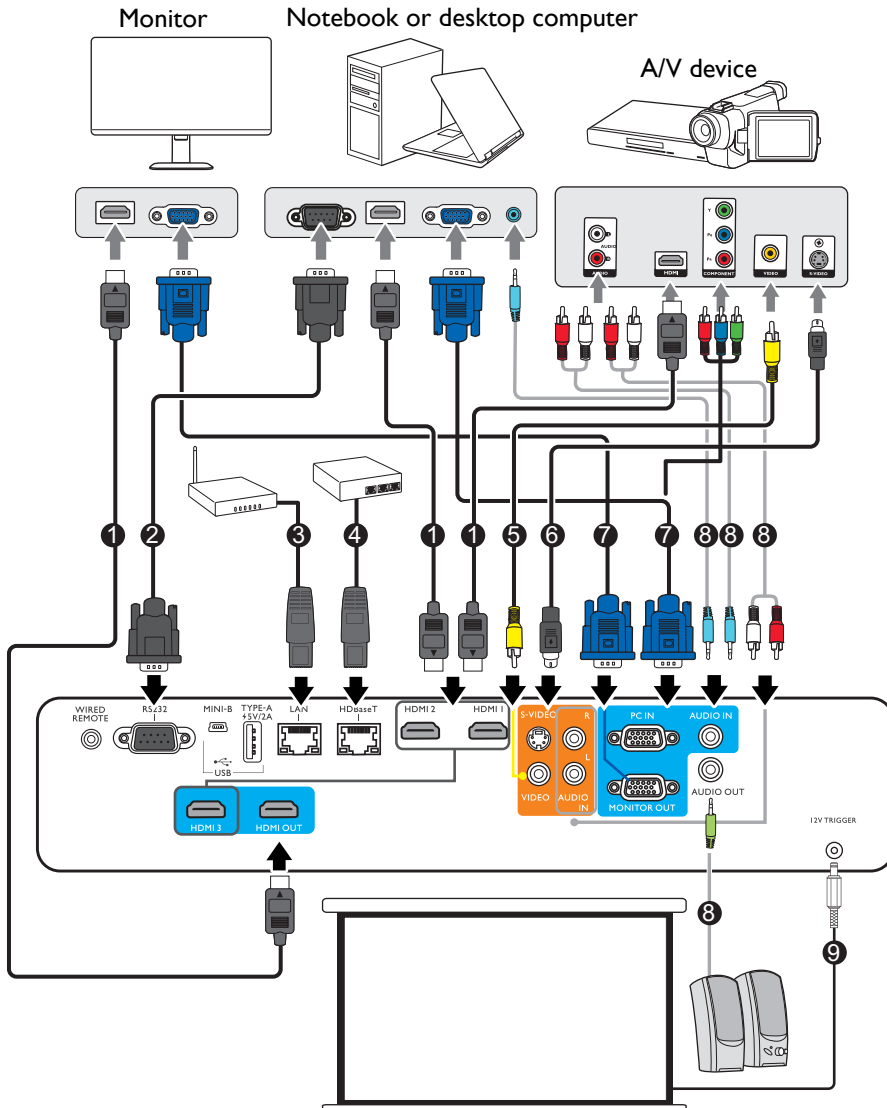





| | |
|---|-------------------------|
| 1 | HDMI cable |
| 2 | RS232 cable |
| 3 | RJ-45 cable |
| 4 | HDBaseT matrix switcher |
| 5 | Composite video cable |
| 6 | S-Video cable |
| 7 | VGA cable |
| 8 | Audio cable |
| 9 | Electric screen, etc. |



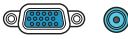

- In the connections above, some cables may not be included with the projector (see [Shipping contents on page 6](#)). They are commercially available from electronics stores.
- The connection illustrations are for reference only.
- Before connecting a cable to the projector or to a device that is connected to the projector, touch any nearby metallic objects to remove any static electricity from your body.
- Do not use unnecessarily long cables to connect the projector or a device to the projector. Using a longer cable that is wound makes it act like an antenna, making it more susceptible to noise.
- When connecting cables, connect GND first and then insert the connecting terminal of the connecting device.
- Many notebooks do not turn on their external video ports when connected to a projector. Usually a key combo like FN + function key with a monitor symbol turns the external display on/off. Press FN and the labeled function key simultaneously. Refer to your notebook's documentation to find your notebook's key combination.
- If the selected video image is not displayed after the projector is turned on and the correct video source has been selected, check that the video source device is turned on and operating correctly. Also check that the signal cables have been connected correctly.

You need only connect the projector to a video source device using just one of the connecting methods, however each provides a different level of video quality.

| Terminal | | Picture quality |
|--|---|-----------------|
| HDMI 1/HDMI 2/HDMI 3 |  | Best |
| Component Video (through RGB input) |  | Better |
| S-VIDEO |  | Good |
| VIDEO |  | Normal |
| PC IN |  | Normal |

Operation

Starting up the projector

1. Plug the power cord. Turn on the power outlet switch (where fitted). The power indicator on the projector lights orange after power has been applied.
2. Press  on the projector or  on the remote control to start the projector. The power indicator flashes green and stays green when the projector is on.

The start up procedure takes about 30 seconds. In the later stage of start up, a startup logo is projected.

(If necessary) Rotate the focus ring to adjust the image clearness.

3. If the projector is activated for the first time, select your OSD language following the on-screen instructions.
4. If you are prompted for a password, press the arrow keys to enter a 6-digit password. See [Utilizing the password function on page 24](#).
5. Switch all of the connected equipment on.
6. The projector will search for input signals. The current input signal being scanned appears. If the projector does not detect a valid signal, the message “No Signal” will continue displaying until an input signal is found.

You can also press **SOURCE** to select your desired input signal. See [Switching input signal on page 25](#).

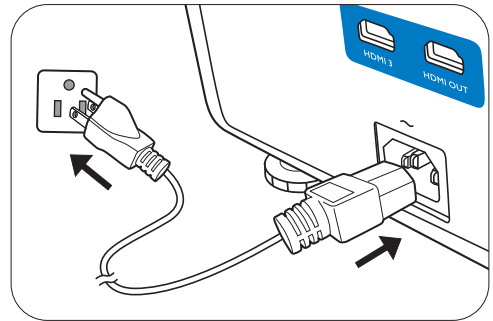

- Please use the original accessories (e.g. power cord) to avoid possible dangers such as electric shock and fire.
- The Setup Wizard screenshots are for reference only and may differ from the actual design.
- If the frequency/resolution of the input signal exceeds the projector's operating range, you will see the message “Out of Range” displayed on the background screen. Please change to an input signal which is compatible with the projector's resolution or set the input signal to a lower setting. See [Timing chart on page 47](#).
- If no signal is detected for 3 minutes, the projector automatically enters saving mode.

Using the menus

The projector is equipped with On-Screen Display (OSD) menus for making various adjustments and settings.



The OSD screenshots below are for reference only, and may differ from the actual design.

The projector is equipped with 2 types of On-Screen Display (OSD) menus for making various adjustments and settings.

- **Basic** OSD menu: provides primary menu functions. (See [Basic menu on page 27](#))
- **Advanced** OSD menu: provides full menu functions. (See [Advanced menu on page 29](#))

To access the OSD menu, press **MENU** on the projector or remote control.

- Use the arrow keys ($\blacktriangle/\blacktriangledown/\blacktriangleleft/\blacktriangleright$) on the projector or remote control to move through the menu items.
- Use **OK** on the projector or remote control to confirm the selected menu item.

The first time you use the projector (after finishing the initial setup), Basic OSD menu displays.



The OSD screenshots below are for reference only, and may differ from the actual design.

Below is the overview of the **Basic OSD** menu.

| | | |
|--|-------------------------------|---|
| | <p>1 Menu Type</p> | <p>4 Press OK to enter the menu.</p> |
| | <p>2 Main menu</p> | <p>5 Status</p> |
| | <p>3 Current input signal</p> | <p>6 Press MENU to go to the previous page or to exit.</p> |

If you intend to switch from the **Basic OSD** menu to the **Advanced OSD** menu, follow the instructions below:

1. Go to **Basic Menu > Menu Type**.
2. Press **OK** and press $\blacktriangle/\blacktriangledown$ to select **Advanced**. Next time when you turn on the projector, you may access the **Advanced OSD** menu by pressing **MENU**.

Below is the overview of the **Advanced OSD** menu.

| | | |
|--|---|---|
| | <p>1 Main menu & Main menu icon</p> | <p>5 Press BACK to go to the previous page.</p> |
| | <p>2 Sub-menu</p> | <p>6 Press MENU to go to the previous page or to exit.</p> |
| | <p>3 Current input signal</p> | <p>7 Status</p> |
| | <p>4 Press OK to enter the menu.</p> | |

Likewise, when you wish to switch from the **Advanced OSD** menu to the **Basic OSD** menu, follow the instructions below:

1. Go to **Advanced Menu - System > Menu Settings** and press **OK**.
 2. Select **Menu Type** and **OK**.
- Press $\blacktriangle/\blacktriangledown$ to select **Basic**. Next time when you turn on the projector, you may access the **Basic OSD** menu by pressing **MENU**.

Securing the projector

Using a security cable lock

The projector has to be installed in a safe place to prevent theft. Otherwise, purchase a lock, such as the Kensington lock, to secure the projector. You can locate a Kensington lock slot on the rear side of the projector. See item 11 on [page 7](#).

A Kensington security cable lock is usually a combination of key(s) and the lock. Refer to the lock's documentation for finding out how to use it.

Utilizing the password function

Setting a password

1. Go to **Advanced Menu - Settings > Security Settings**. Press **OK**. The **Security Settings** page appears.
2. Highlight **Change Password** and press **OK**.
3. The four arrow keys (▲, ►, ▼, ◀) respectively represent 4 digits (1, 2, 3, 4). According to the password you desire to set, press the arrow keys to enter six digits for the password.
4. Confirm the new password by re-entering the new password.
Once the password is set, the OSD menu returns to the **Security Settings** page.
5. To activate the **Power On Lock** function, press ▲/▼ to highlight **Power On Lock** and press ◀/▶ to select **On**. Input the password again.

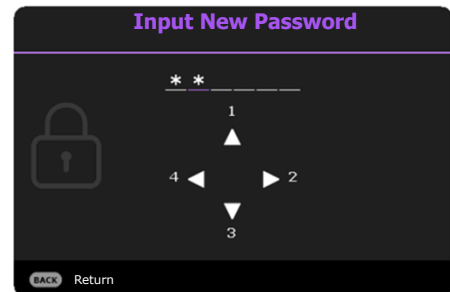

- The digits being input will display as asterisks on-screen. Make a note of your selected password and keep it in a safe place in advance or right after the password is entered so that it is available to you should you ever forget it.
- Once a password has been set and the power on lock is activated, the projector cannot be used unless the correct password is entered every time the projector is started.

If you forget the password

If you enter the wrong password, the password error message will appear, and the **Input Current Password** message follows. If you absolutely do not remember the password, you can use the password recall procedure. See [Entering the password recall procedure on page 24](#).

If you enter an incorrect password 5 times in succession, the projector will automatically shut down in a short time.

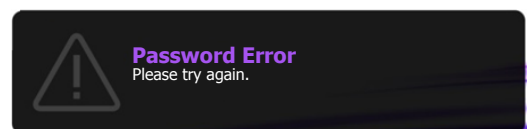

Entering the password recall procedure

1. Press and hold **AUTO** for 3 seconds. The projector will display a coded number on the screen.
2. Write down the number and turn off your projector.
3. Seek help from the local BenQ service center to decode the number. You may be required to provide proof of purchase documentation to verify that you are an authorized user of the projector.

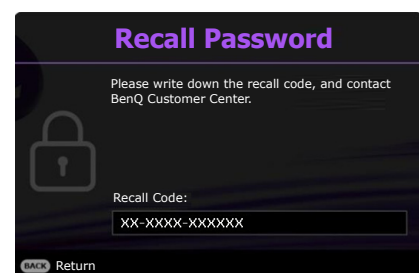

Changing the password

1. Go to **Advanced Menu - Settings > Security Settings > Change Password**.
2. Press **OK**. The message “**Input Current Password**” appears.
3. Enter the old password.
 - If the password is correct, another message “**Input New Password**” appears.
 - If the password is incorrect, the password error message will appear, and the message “**Input Current Password**” appears for your retry. You can press **BACK** to cancel the change or try another password.
4. Enter a new password.
5. Confirm the new password by re-entering the new password.

Disabling the password function

To disable password protection, go to **Advanced Menu - Settings > Security Settings > Power On Lock** and press **◀/▶** to select **Off**. The message “**Input Current Password**” appears. Enter the current password.

- If the password is correct, the OSD menu returns to the **Security Settings** page. You will not have to enter the password next time turning on the projector.
- If the password is incorrect, the password error message will appear, and the message “**Input Current Password**” appears for your retry. You can press **BACK** to cancel the change or try another password.



Though the password function is disabled, you need to keep the old password in hand should you ever need to re-activate the password function by entering the old password.

Switching input signal

The projector can be connected to multiple devices at the same time. However, it can only display one full screen at a time. When starting up, the projector automatically searches for the available signals.

Be sure the **Advanced Menu - Settings > Auto Source Search** menu is **On** if you want the projector to automatically search for the signals.

To select the source:

1. Press **SOURCE**. A source selection bar appears.
2. Press **▲/▼/◀/▶** until your desired signal is selected and press **OK**.



Once detected, the selected source information will appear at the corner of the screen for seconds. If there is multiple equipment connected to the projector, repeat steps 1-2 to search for another signal.

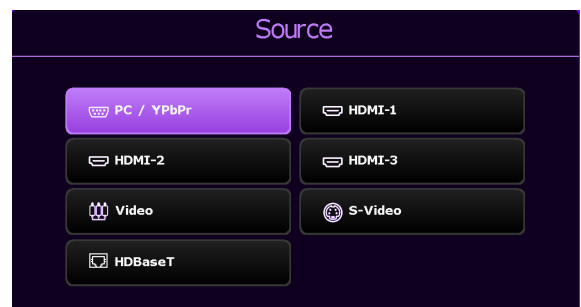

- The brightness level of the projected image will change accordingly when you switch between different input signals.
- For best display picture results, you should select and use an input signal which outputs at the projector’s native resolution. Any other resolutions will be scaled by the projector depending upon the “aspect ratio” setting, which may cause some image distortion or loss of picture clarity. See [Aspect Ratio on page 27](#).



Shutting down the projector

1. Press  and a confirmation message will appear prompting you. If you don't respond in a few seconds, the message will disappear.
2. Press  a second time. The **POWER indicator light** flashes orange, the projection light source shuts down.
3. Once the cooling process finishes, the **POWER indicator light** is a steady orange and fans stop. Disconnect the power cord from the power outlet.

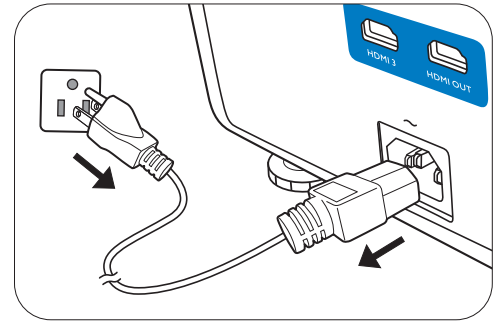

- To protect the light source, the projector will not respond to any commands during the cooling process.

- Press  again to start the projector after the **POWER indicator light** turns a steady orange.

Menu operation

Please note that the on-screen display (OSD) menus vary according to the signal type selected and the projector model you are using.

The menu items are available when the projector detects at least one valid signal. If there is no equipment connected to the projector or no signal detected, limited menu items are accessible.

Basic menu

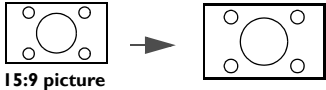
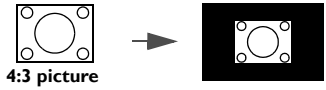
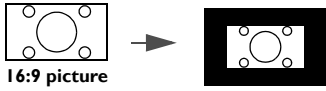
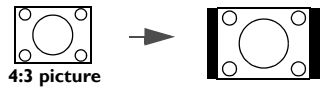
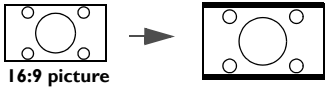
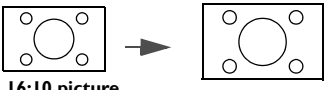
| | |
|----------------------------|--|
| <p>Brightness</p> | <p>The higher the value, the brighter the image. Adjust this control so the black areas of the image appear just as black and that detail in the dark areas is visible.</p> |
| <p>Aspect Ratio</p> | <p>There are several options to set the image's aspect ratio depending on your input signal source.</p> <ul style="list-style-type: none"> <p>• Auto: Scales an image proportionally to fit the projector's native resolution in its horizontal or vertical width.</p>  <p>• Real: Projects an image as its original resolution and resizes it to fit within the display area. For input signals with lower resolutions, the projected image will be displayed in its original size.</p>  <p>• 4:3: Scales an image so that it is displayed in the center of the screen with a 4:3 aspect ratio.</p>  <p>• 16:9: Scales an image so that it is displayed in the center of the screen with a 16:9 aspect ratio.</p>  <p>• 16:10: Scales an image so that it is displayed in the center of the screen with a 16:10 aspect ratio.</p>  <p>• 16:10: Scales an image so that it is displayed in the center of the screen with a 16:10 aspect ratio.</p>  |

| | |
|---------------------------------|---|
| <p>Picture Mode</p> | <p>The projector is preset with several predefined picture modes so that you can choose one to suit your operating environment and input signal picture type.</p> <ul style="list-style-type: none"> • Bright: Maximizes the brightness of the projected image. This mode is suitable for environments where extra-high brightness is required, such as using the projector in well lit rooms. • Presentation: Is designed for presentations. The brightness is emphasized in this mode to match PC and notebook coloring. • sRGB: Maximizes the purity of RGB colors to provide true-to-life images regardless of brightness setting. It is most suitable for viewing photos taken with an sRGB compatible and properly calibrated camera, and for viewing PC graphic and drawing applications such as AutoCAD. • Vivid: Is suitable for playing movies in rooms where there is a small amount of ambient light, eg. your living room. • DICOM SIM: Follows the standard of DICOM to get the gray level parameter. • User 1/User 2: Recalls the settings customized based on the current available picture modes. See Reference Mode on page 29. |
| <p>Volume</p> | <p>Adjusts the sound level.</p> |
| <p>Light Source Mode</p> | <p>See Setting the Light Source Mode on page 41.</p> |
| <p>Information</p> | <ul style="list-style-type: none"> • Native Resolution: Shows the native resolution of the projector. • Detected Resolution: Shows the native resolution of the input signal. • Source: Shows the current signal source. • Picture Mode: Shows the selected mode in the Picture menu. • Light Source Mode: Shows the selected mode in the Light Source Settings menu. • 3D Format: Shows the current 3D mode. • Color System: Shows input system format. • Light Source Usage Time: Shows the number of hours the lamp has been used. • Projector ID: Shows projector ID of the projector. • Firmware Version: Shows the firmware version of your projector. |
| <p>Menu Type</p> | <p>Switches to the Advanced OSD menu. See Using the menus on page 22.</p> |

Advanced menu





Picture



| | |
|------------------------------|---|
| <p>Picture Mode</p> | <p>The projector is preset with several predefined picture modes so that you can choose one to suit your operating environment and input signal picture type.</p> <ul style="list-style-type: none"> • Bright: Maximizes the brightness of the projected image. This mode is suitable for environments where extra-high brightness is required, such as using the projector in well lit rooms. • Presentation: Is designed for presentations. The brightness is emphasized in this mode to match PC and notebook coloring. • sRGB: Maximizes the purity of RGB colors to provide true-to-life images regardless of brightness setting. It is most suitable for viewing photos taken with an sRGB compatible and properly calibrated camera, and for viewing PC graphic and drawing applications such as AutoCAD. • Vivid: Is suitable for playing movies in rooms where there is a small amount of ambient light, eg. your living room. • DICOM SIM: Follows the standard of DICOM to get the gray level parameter. • User 1/User 2: Recalls the settings customized based on the current available picture modes. See Reference Mode on page 29. |
| <p>Reference Mode</p> | <p>There are 2 user-definable modes if the current available picture modes are not suitable for your need. You can use one of the picture modes (except the User 1/User 2) as a starting point and customize the settings.</p> <ol style="list-style-type: none"> 1. Go to Picture > Picture Mode. 2. Press ◀/▶ to select User 1 or User 2. 3. Press ▼ to highlight Reference Mode, and press ◀/▶ to select a picture mode that is closest to your need. 4. Press ▼ to select a menu item to be changed and adjust the value. The adjustments define the selected user mode. |
| <p>Brightness</p> | <p>The higher the value, the brighter the image. Adjust this control so the black areas of the image appear just as black and that detail in the dark areas is visible.</p> |
| <p>Contrast</p> | <p>The higher the value, the greater the contrast. Use this to set the peak white level after you have previously adjusted the Brightness setting to suit your selected input and viewing environment.</p> |
| <p>Color</p> | <p>Lower setting produces less saturated colors. If the setting is too high, colors on the image will be overpowering, which makes the image unrealistic.</p> |
| <p>Tint</p> | <p>The higher the value, the more greenish the picture becomes. The lower the value, the more reddish the picture becomes.</p> |
| <p>Sharpness</p> | <p>The higher the value, the sharper the picture becomes.</p> |

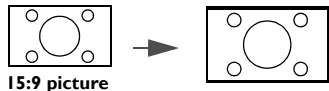
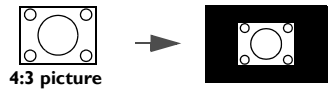
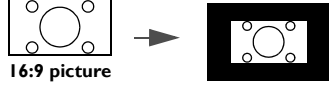

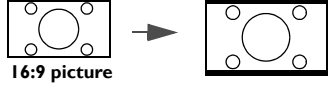
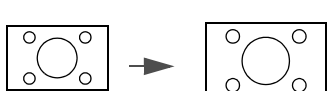
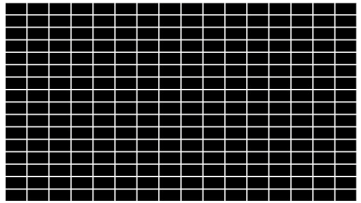
| | |
|---------------------------------------|--|
| <p>Brilliant Color</p> | <p>This feature utilizes a new color-processing algorithm and system level enhancements to enable higher brightness while providing truer, more vibrant colors in picture. It enables a greater than 50% brightness increase in mid-tone images, which are common in video and natural scenes, so the projector reproduces images in realistic and true colors. If you prefer images with that quality, select On. When Off is selected, the Color Temperature function is not available.</p> |
| <p>Advanced Color Settings</p> | <p>Color Temperature</p> <p>There are several preset color temperature settings available. The available settings may vary according to the signal type selected.</p> <ul style="list-style-type: none"> • Normal: Maintains normal colorings for white. • Cool: Makes images appear bluish white. • Warm: Makes images appear reddish white. <p>Color Temperature Tuning</p> <p>You can also set a preferred color temperature by adjusting the following options.</p> <ul style="list-style-type: none"> • R Gain/G Gain/B Gain: Adjusts the contrast levels of Red, Green, and Blue. • R Offset/G Offset/B Offset: Adjusts the brightness levels of Red, Green, and Blue. <p>Color Management</p> <p>This function provides six sets (RGBCMY) of colors to be adjusted. When you select each color, you can independently adjust its range and saturation according to your preference.</p> <ul style="list-style-type: none"> • Primary Color: Selects a color from among R (Red), G (Green), B (Blue), C (Cyan), M (Magenta), or Y (Yellow). • Hue: Increase in the range will include colors consisted of more proportions of its two adjacent colors. Please refer to the illustration for how the colors relate to each other. For example, if you select Red and set its range at 0, only pure red in the projected picture will be selected. Increasing its range will include red close to yellow and red close to magenta. • Saturation: Adjusts the values to your preference. Every adjustment made will reflect to the image immediately. For example, if you select Red and set its value at 0, only the saturation of pure red will be affected. <div data-bbox="1107 1223 1461 1554" data-label="Diagram"> </div> <p> Saturation is the amount of that color in a video picture. Lower settings produce less saturated colors; a setting of “0” removes that color from the image entirely. If the saturation is too high, that color will be overpowering and unrealistic.</p> <ul style="list-style-type: none"> • Gain: Adjusts the values to your preference. The contrast level of the primary color you select will be affected. Every adjustment made will reflect to the image immediately. |

| | |
|---------------------------------------|---|
| <p>Advanced Color Settings</p> | <p>Wall Color</p> <p>Corrects the projected picture's color when the projection surface such as a painted wall which may not be white, the Wall Color feature can help correct the projected picture's colors to prevent possible color difference between the source and projected pictures. There are several precalibrated colors to choose from: Light Yellow, Pink, Light Green, Blue, and Blackboard.</p> |
| <p>Reset Picture</p> | <p>Returns all of the adjustments you've made for the Picture menu to the factory preset values.</p> |

Display

| | |
|---|---|
| <p>Aspect Ratio</p> | <p>There are several options to set the image's aspect ratio depending on your input signal source.</p> <ul style="list-style-type: none"> • Auto: Scales an image proportionally to fit the projector's native resolution in its horizontal or vertical width. • Real: Projects an image as its original resolution and resizes it to fit within the display area. For input signals with lower resolutions, the projected image will be displayed in its original size. • 4:3: Scales an image so that it is displayed in the center of the screen with a 4:3 aspect ratio. • 16:9: Scales an image so that it is displayed in the center of the screen with a 16:9 aspect ratio. • 16:10: Scales an image so that it is displayed in the center of the screen with a 16:10 aspect ratio. <div style="display: flex; justify-content: space-around; align-items: center;"> <div style="text-align: center;">  <p>15:9 picture</p> </div> <div style="text-align: center;">  <p>4:3 picture</p> </div> <div style="text-align: center;">  <p>16:9 picture</p> </div> <div style="text-align: center;">  <p>4:3 picture</p> </div> <div style="text-align: center;">  <p>16:9 picture</p> </div> <div style="text-align: center;">  <p>16:10 picture</p> </div> </div> |
| <p>2D Keystone</p> | <p>See Correcting keystone on page 18.</p> |
| <p>Corner Fit</p> | <p>See Adjusting Corner Fit on page 19.</p> |
| <p>Test Pattern</p> | <p>Adjusts the image size and focus and check that the projected image is free from distortion.</p>  |
| <p>PC & Component YPbPr Tuning</p> | <ul style="list-style-type: none"> • Phase: Adjusts the clock phase to reduce image distortion. This function is only available when a PC signal (analog RGB) or YPbPr signal is selected. • H. Size: Adjusts the horizontal width of the image. This function is only available when a PC signal (analog RGB) is selected.  |



| | |
|---------------------------|---|
| <p>Position</p> | <p>Displays the position adjustment page. To move the projected image, use the directional arrow keys. This function is only available when a PC signal (analog RGB) is selected.</p> |
| <p>Auto Sync</p> | <ul style="list-style-type: none"> • On: Allows the projector to automatically determines the best picture timings for the displayed image when PC signal (analog RGB) is selected and AUTO is pressed. • Off: Disables the auto sync function and applies the saved settings of Phase, H. Size and Position.  <p>Off is only available under specific timings and Auto Sync will be automatically grayed out if not applicable.</p> |
| <p>3D</p> | <p>This projector features a 3D function which enables you to enjoy the 3D movies, videos, and sporting events in a more realistic way by presenting the depth of the images. You need to wear a pair of 3D glasses to view the 3D images.</p> <ul style="list-style-type: none"> • 3D Mode: The default setting is Off. If you want the projector to automatically choose an appropriate 3D format when detecting 3D contents, select Auto. If the projector cannot recognize the 3D format, press ▲/▼ to choose a 3D mode from among Top Bottom, Frame Sequential, Frame Packing and Side by Side.  <p>When 3D function is activated:</p> <ul style="list-style-type: none"> • The brightness level of the projected image will decrease. • The following settings cannot be adjusted: Picture Mode, Reference Mode. • The 2D Keystone can only be adjusted within limited degrees. • 3D Sync Invert: When you discover the inversion of the image depth, enable this function to correct the problem. • Apply 3D Settings: After the 3D settings are saved, you can decide if you would like to apply them by choosing a set of 3D settings that you have saved. Once applied, the projector will automatically play the incoming 3D contents if it matches the 3D settings saved.  <p>Only the set(s) of 3D settings with memorized data is available.</p> <ul style="list-style-type: none"> • Save 3D Settings: When you have successfully displayed the 3D contents after making the appropriate adjustments, you can enable this function and choose a set of 3D settings to memorize current 3D settings. |
| <p>HDMI Format</p> | <p>Selects a suitable color format to optimize display quality.</p> <ul style="list-style-type: none"> • Auto: Automatically selects a suitable color space and gray level for the incoming HDMI signal. • RGB Limited: Utilizes the Limited range RGB 16-235. • RGB Full: Utilizes the Full range RGB 0-255. • YUV Limited: Utilizes the Limited range YUV 16-235. • YUV Full: Utilizes the Full range YUV 0-255. |

| | |
|------------------------------|---|
| <p>Image Resizing</p> | <p>Digital Zoom</p> <p>Magnifies or reduces the projected image.</p> <ol style="list-style-type: none"> 1. After the Zoom bar displays, press ▲ repeatedly to magnify the picture to a desired size. 2. To navigate the picture, press OK to switch to the panning mode and press the directional arrows (▲, ▼, ◀, ▶) on the projector or remote control to navigate the picture. 3. To reduce size of the picture, press OK to switch back to the zoom in/out function, and press AUTO to restore the picture to its original size. You can also press repeatedly until it is restored to the original size.  <p>The picture can only be navigated after it is magnified. You can further magnify the picture while searching for details.</p> |
| | <p>Digital Shrink & Shift</p> <p>Shrinks and/or shifts the projected image.</p> <ol style="list-style-type: none"> 1. After the adjustment bar displays, press ◀/▶ repeatedly to shrink or magnify the picture to a desired size. 2. Press OK to activate digital shift function. 3. After digital shift function is activated, press the directional arrows (▲, ▼, ◀, ▶) to shift the image. 4. Press AUTO to restore the picture to its original size.  <p>The picture can only be shifted after it shrank.</p> |
| <p>Reset Display</p> | <p>Returns all of the adjustments you've made for the Display menu to the factory preset values.</p>  <p>The following settings will still remain: 2D Keystone, Corner Fit, Image Resizing.</p> |

Network

| | |
|------------------------------------|---|
| <p>Wired LAN</p> | <p>See BenQ Network Projector Operation Guide, which can be downloaded from BenQ product webpage.</p> |
| <p>AMX Device Discovery</p> | <p>When this function is On, the projector can be detected by AMX controller.</p> |
| <p>MAC Address (Wired)</p> | <p>Displays the mac address for this projector.</p> |

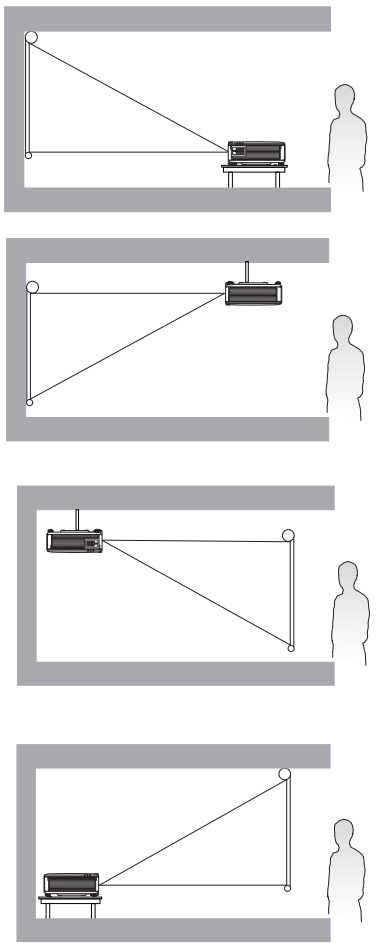
Settings

| | | |
|--------------------------------------|---|--|
| <p>Projector Installation</p> | <ul style="list-style-type: none"> • Front Table Select this location with the projector placed on the table in front of the screen. This is the most common way to position the projector for quick setup and portability. • Front Ceiling Select this location with the projector suspended upside-down from the ceiling in front of the screen. Purchase the BenQ Projector Ceiling Mount Kit from your dealer to mount your projector on the ceiling. • Rear Ceiling Select this location with the projector suspended upside-down from the ceiling behind the screen. Note that a special rear projection screen and the BenQ Projector Ceiling Mount Kit are required for this installation location. • Rear Table Select this location with the projector placed on the table behind the screen. Note that a special rear projection screen is required. |  |
| <p>Remote Receiver</p> | <p>Allows you to enable all the remote receivers or one specific remote receiver on the projector.</p> | |
| <p>Auto Source Search</p> | <ul style="list-style-type: none"> • Allows the projector to automatically search for a signal.  <p>The following signal source(s) will not be automatically detected by the projector, and you'll have to manually select it from the source selection bar: Network Display, USB Reader.</p> | |
| <p>Auto Signal Adjustment</p> | <ul style="list-style-type: none"> • On: Allows the projector to automatically determines the best picture timings for the displayed image when PC signal (analog RGB) is selected and AUTO is pressed. • Off: The projector will not respond when AUTO is pressed. | |
| <p>Light Source Settings</p> | <ul style="list-style-type: none"> • Light Source Mode: See Setting the Light Source Mode on page 41. • Light Source Information: Displays the number of hours the lamp has been used. | |

**Operation
Settings**

Blank Timer

Sets the image blank time when there is no action taken on the blank screen, once elapsed the image will return to the screen. If the preset time spans are not suitable for your need, select **Disable**. No matter **Blank Timer** is activated or not, you can press most of the keys on the projector or remote control to restore the picture.

Reminder Message

Sets the reminder messages on or off.

High Altitude Mode



We recommend you turn on the **High Altitude Mode** when your environment is between 1500 m –3000 m above sea level, and ambient temperature is between 0°C–30°C.



You can also select **Auto**, allowing the projector to automatically detect the altitude and display reminder message suggesting you to adjust the setting when necessary.

Operation under "**High Altitude Mode**" may cause a higher decibel operating noise level because of increased fan speed necessary to improve overall system cooling and performance.

If you use this projector under other extreme conditions excluding the above, it may display auto shut-down symptoms, which is designed to protect your projector from over-heating. In cases like this, you should switch to High Altitude mode to solve these symptoms. However, this is not to state that this projector can operate under any and all harsh or extreme conditions.

Power On/Off Settings



- **Direct Power On:** Allows the projector to turn on automatically once the power is fed through the power cord.
- **Signal Power On:** Sets whether to turn the projector directly on without pressing  **POWER** or  **ON** when the projector is in standby mode and detects a VGA signal.
- **Auto Power Off:** Allows the projector to turn off automatically if no input signal is detected after a set period of time to prevent unnecessary waste of lamp life.
- **Power Off Timer:** Sets the auto-shutdown timer.

| | |
|-----------------------------------|---|
| <p>Security Settings</p> | <p>Panel Key Lock</p> <p>With the control keys on the projector locked, you can prevent your projector settings from being changed accidentally (by children, for example). When the Panel Key Lock is on, no control keys on the projector will operate except  POWER.</p> <p>To release panel key lock, press and hold  (the right key) for 3 seconds on the projector or turn this function off using the remote control.</p> <p></p> <p>If you turn off the projector without disabling panel key lock, the projector will still be in locked status the next time it is turned on.</p> <p>Change Password</p> <p>See Utilizing the password function on page 24.</p> <p>Power On Lock</p> <p>See Utilizing the password function on page 24.</p> |
| <p>Serial Port Setting</p> | <p>Port Selection</p> <p>Allows you to select a preferred control port: through the RS-232C port (RS232 port on the projector) or the HDBaseT port (HDBaseT input port on the projector).</p> <p>Baud Rate</p> <p>Selects a baud rate that is identical with your computer's so that you can connect the projector using a suitable RS-232 cable and update or download the projector's firmware. This function is intended for qualified service personnel.</p> |
| <p>HDMI Equalizer</p> | <p>Adjusts the equalizer gain settings for an HDMI signal. The higher the setting, the stronger the gain value. If there are more than one HDMI port on the projector, select the HDMI port first before adjusting the value.</p> |
| <p>Image Memory</p> | <p>Save Image Memory</p> <p>Allows you to save and apply several sets of image settings for regularly used circumstances, including the following settings: Projector Installation, Aspect Ratio, Picture Mode, Source, Resolution, Light Source Mode, Digital Shrink & Shift. You can choose one set of memory to save the current settings.</p> <p>Apply Image Memory</p> <p>After the image memories are saved, you can decide if you would like to apply it by choosing a set of memory that you have saved.</p> <p>Rename</p> <p>Renames the image memories.</p> |

| | |
|-------------------------------------|---|
| <p>Projector ID Settings</p> | <p>Sets the projector ID for this projector (between 01~99). When multiple adjacent projectors are in operation at the same time, switching the projector ID codes can prevent interference from other remote controls. After the Projector ID is set, switch to the same ID for the remote control to control this projector. See Remote control on page 10</p> <p>Set the ID</p> <ol style="list-style-type: none"> 1. Press and hold ID SET until the ID setting indicator lights up. 2. Enter the ID for the remote control (between 01~99). The remote control ID should be the same as the corresponding projector ID. 3. The ID is saved successfully when you see the ID setting indicator starts flickering and then blackout. <p>Clear the ID</p> <ol style="list-style-type: none"> 1. Press and hold ID SET until the ID setting indicator lights up. 2. Press ALL to clear current ID setting of the remote control. 3. The ID is cleared successfully when you see the ID setting indicator starts flickering and then blackout. |
| <p>Reset Settings</p> | <p>Returns all of the adjustments you've made for the Settings menu to the factory preset values.</p> |

System

| | | | | | |
|---|---|---|--|---|---|
| <p>Language</p> | <p>Sets the language for the On-Screen Display (OSD) menus.</p> | | | | |
| <p>Standby Settings</p> | <ul style="list-style-type: none"> • Network: Allows you to make following settings: <table border="1" data-bbox="375 1182 1453 1496"> <tr> <td data-bbox="375 1182 694 1265"> <p>Enable Network Standby Mode</p> </td> <td data-bbox="694 1182 1453 1265"> <p>Allows the projector to provide the network function in standby mode.</p> </td> </tr> <tr> <td data-bbox="375 1265 694 1496"> <p>Switch to Normal Standby Mode</p> </td> <td data-bbox="694 1265 1453 1496"> <p>Allows the projector to disable the network function after a set period of time after it enters standby mode. For instance, if 20 min is selected, the projector is able to provide the network function for 20 minutes after it enters standby mode. When 20 minutes is up, the projector enters normal standby mode.</p> </td> </tr> </table> • Monitor Out: Allows the projector to output a VGA signal when it is in standby mode and the PC IN jack and the MONITOR OUT jack are correctly connected to devices. • HDMI Out: Allows the projector to output an HDMI signal when it is in standby mode and the HDMI 3 jack and the HDMI OUT jack are correctly connected to devices. • Audio Pass Through: The projector can play sound when it is in standby mode and the corresponding jacks are correctly connected to devices. Press ◀/▶ to choose the source that you wish to use. See Connection on page 20 for how to make the connection. | <p>Enable Network Standby Mode</p> | <p>Allows the projector to provide the network function in standby mode.</p> | <p>Switch to Normal Standby Mode</p> | <p>Allows the projector to disable the network function after a set period of time after it enters standby mode. For instance, if 20 min is selected, the projector is able to provide the network function for 20 minutes after it enters standby mode. When 20 minutes is up, the projector enters normal standby mode.</p> |
| <p>Enable Network Standby Mode</p> | <p>Allows the projector to provide the network function in standby mode.</p> | | | | |
| <p>Switch to Normal Standby Mode</p> | <p>Allows the projector to disable the network function after a set period of time after it enters standby mode. For instance, if 20 min is selected, the projector is able to provide the network function for 20 minutes after it enters standby mode. When 20 minutes is up, the projector enters normal standby mode.</p> | | | | |

| | |
|----------------------------|--|
| Background Settings | <ul style="list-style-type: none"> • Background: Sets the background color for the projector. • Splash Screen: Allows you to select which logo screen will be displayed during projector start-up. |
| Menu Settings | <ul style="list-style-type: none"> • Menu Type: Switches to the Basic OSD menu. • Menu Display Time: Sets the length of time the OSD will remain active after your last key press. |
| Audio Settings | <ul style="list-style-type: none"> • Mute: Temporarily turns off the sound. • Volume: Adjusts the sound level. • Power On/Off Ring Tone: Turns on or off the ring tone when the projector is in startup and shutdown process.  <p>The only way to change Power On/Off Ring Tone is setting On or Off here. Setting the sound mute or changing the sound level will not affect the Power On/Off Ring Tone.</p> |
| Closed Caption | <ul style="list-style-type: none"> • Closed Caption Enable: Activates the function by selecting On when the selected input signal carries closed captions.  <p>Captions: An on-screen display of the dialogue, narration, and sound effects of TV programs and videos that are closed captioned (usually marked as "CC" in TV listings).</p> <ul style="list-style-type: none"> • Caption Version: Selects a preferred closed captioning mode. To view captions, select CC1, CC2, CC3, or CC4 (CC1 displays captions in the primary language in your area). |
| Factory Default | <p>Returns all settings to the factory preset values.</p>  <p>The following settings will still remain: 2D Keystone, Corner Fit, Projector Installation, Light Source Usage Time, High Altitude Mode, Security Settings, Baud Rate, Digital Shrink & Shift.</p> |
| Reset System | <p>Returns all of the adjustments you've made for the System menu to the factory preset values.</p> |

INFORMATION menu

| | |
|------------------------------|---|
| Current System Status | <ul style="list-style-type: none">• Native Resolution: Shows the native resolution of the projector.• Detected Resolution: Shows the native resolution of the input signal.• Source: Shows the current signal source.• Picture Mode: Shows the selected mode in the Picture menu.• Light Source Mode: Shows the selected mode in the Light Source Settings menu.• 3D Format: Shows the current 3D mode.• Color System: Shows input system format.• Light Source Usage Time: Shows the number of hours the lamp has been used.• Projector ID: Shows projector ID of the projector.• Firmware Version: Shows the firmware version of your projector. |
|------------------------------|---|

Maintenance

Care of the projector

Cleaning the lens

Clean the lens whenever you notice dirt or dust on the surface. Please be sure to turn off the projector and let it cool down completely before cleaning the lens.

- Use a canister of compressed air to remove dust.
- If there is dirt or smears, use lens-cleaning paper or moisten a soft cloth with lens cleaner and gently wipe the lens surface.
- Never use any type of abrasive pad, alkaline/acid cleaner, scouring powder, or volatile solvent, such as alcohol, benzene, thinner or insecticide. Using such materials or maintaining prolonged contact with rubber or vinyl materials may result in damage to the projector surface and cabinet material.

Cleaning the projector case

Before you clean the case, turn the projector off using the proper shutdown procedure as described in [Shutting down the projector on page 26](#) and unplug the power cord.

- To remove dirt or dust, wipe the case with a soft, lint-free cloth.
- To remove stubborn dirt or stains, moisten a soft cloth with water and a neutral pH detergent. Then wipe the case.



Never use wax, alcohol, benzene, thinner or other chemical detergents. These can damage the case.

Storing the projector

If you need to store the projector for an extended time, please follow the instructions below:

- Make sure the temperature and humidity of the storage area are within the recommended range for the projector. Please refer to [Specifications on page 45](#) or consult your dealer about the range.
- Retract the adjuster feet.
- Remove the battery from the remote control.
- Pack the projector in its original packing or equivalent.

Transporting the projector

It is recommended that you ship the projector with its original packing or equivalent.

Light source information

Getting to know the light source hour

When the projector is in operation, the duration (in hours) of light source usage is automatically calculated by the built-in timer. The method of calculating the equivalent light source hour is as follows:

Light Source Usage Time = (hours used in **Normal** mode) + (hours used in **Economic** mode) + (hours used in **Dimming** mode) + (hours used in **Custom** mode)

Total (equivalent) light source hour = 1.0 x (hours used in **Normal** mode) + 1.0 x (hours used in **Economic** mode) + 1.0 x (hours used in **Dimming** mode) + 1.0 x (hours used in **Custom** mode)

To obtain the light source hour information:

1. Go to **Advanced Menu - Settings > Light Source Settings** and press **OK**. The **Light Source Settings** page appears.
2. Press **▼** to select **Light Source Information** and press **OK**. The **Light Source Information** is displayed.

You can also get the light source hour information on the **INFORMATION** menu.

Extending light source life

- Setting the **Light Source Mode**

Go to **Advanced Menu - Settings > Light Source Settings > Light Source Mode** or press **LIGHT SOURCE** on the remote control to select a suitable light source power from among the provided modes.



| Light source mode | Description |
|-------------------|---|
| Normal | Provides full light source brightness |
| Economic | Lowers brightness to extend the light source life and decreases the fan noise |
| Dimming | Lowers brightness to offer a longer light source life |
| Custom | Displays the light source brightness adjustment bar so that you can adjust the setting to your liking |

- Setting **Auto Power Off**





























































This function allows the projector to turn off automatically if no input signal is detected after a set period of time to prevent unnecessary waste of light source life.









To set **Auto Power Off**, go to **Advanced Menu - Settings > Operation Settings > Power On/Off Settings > Auto Power Off** and press **◀/▶**.



- The apparent brightness of the projected image will vary depending on the ambient lighting conditions, selected input signal contrast/brightness settings, and is directly proportional to projection distance.
- The light source brightness will decline over time and may vary within the light source manufacturers specifications. This is normal and expected behavior.

LED Indicators

| Light | | | Status & Description |
|---|---|---|---|
| POWER | TEMP | LIGHT | |
| Power events | | | |
|  |  |  | Stand-by mode |
|  |  |  | Powering up |
|  |  |  | Normal operation |
|  |  |  | Normal power-down cooling |
|  |  |  | Downloading |
|  |  |  | Color wheel start fail |
|  |  |  | Phosphor wheel start fail |
|  |  |  | Burn-in ON |
|  |  |  | Burn-in OFF |
| Light source events | | | |
|  |  |  | Light source life exhausted |
|  |  |  | Light source error in normal operation |
|  |  |  | Light source is not lit up |
| Thermal events | | | |
|  |  |  | Fan 1 error (the actual fan speed is outside the desired speed) |
|  |  |  | Fan 2 error (the actual fan speed is outside the desired speed) |
|  |  |  | Fan 3 error (the actual fan speed is outside the desired speed) |
|  |  |  | Fan 4 error (the actual fan speed is outside the desired speed) |
|  |  |  | Fan 5 error (the actual fan speed is outside the desired speed) |
|  |  |  | Fan 6 error (the actual fan speed is outside the desired speed) |
|  |  |  | Fan 7 error (the actual fan speed is outside the desired speed) |
|  |  |  | Fan 8 error (the actual fan speed is outside the desired speed) |
|  |  |  | Temperature 1 error (over limited temperature) |
|  |  |  | Thermal Sensor 1 open error |
|  |  |  | Thermal Sensor 1 short error |
|  |  |  | Thermal IC #1 I2C Connection error |

| | | | | |
|---|---|--|--|--|
|  |  : Off |  : Orange On  : Orange Flashing |  : Green On  : Green Flashing |  : Red On  : Red Flashing |
|---|---|--|--|--|

Troubleshooting

? The projector does not turn on.

| Cause | Remedy |
|---|---|
| There is no power from the power cord. | Plug the power cord into the AC power jack on the projector, and plug the power cord into the power outlet. If the power outlet has a switch, make sure that it is switched on. |
| Attempting to turn the projector on again during the cooling process. | Wait until the cooling down process has completed. |

? No picture

| Cause | Remedy |
|--|--|
| The video source is not turned on or connected correctly. | Turn the video source on and check that the signal cable is connected correctly. |
| The projector is not correctly connected to the input signal device. | Check the connection. |
| The input signal has not been correctly selected. | Select the correct input signal with the SOURCE key. |
| The lens cover is still closed. | Open the lens cover. |

? Blurred image

| Cause | Remedy |
|--|--|
| The projection lens is not correctly focused. | Adjust the focus of the lens using the focus ring. |
| The projector and the screen are not aligned properly. | Adjust the projection angle and direction as well as the height of the projector if necessary. |
| The lens cover is still closed. | Open the lens cover. |

? Remote control does not work.

| Cause | Remedy |
|--|---|
| The batteries are out of power. | Replace both of the batteries with new ones. |
| There is an obstacle between the remote control and the projector. | Remove the obstacle. |
| You are too far away from the projector. | Stand within 8 meters (26 feet) of the projector. |

? The password is incorrect.

| Cause | Remedy |
|-----------------------------------|---|
| You do not remember the password. | See Entering the password recall procedure on page 24 . |

Specifications

Projector specifications



All specifications are subject to change without notice.

Optical

Resolution

1920 (H) x 1200 (V) WUXGA

Display system

1-CHIP DMD

Lens

LU950/LU951:

F = 1.81 to 2.1, f = 14.3 to 22.9 mm

LU951ST:

F = 1.83 to 1.86, f = 8.6 to 9.4 mm

Clear focus range

LU950/LU951:

1.75–5.83 m @ Wide,

2.8–9.32 m @ Tele

LU951ST:

1.04–3.47 m @ Wide,

1.15–3.82 m @ Tele

Light source

Laser diode

Electrical

Power supply

AC100–240V, 5.6 A, 50–60 Hz (Automatic)

Power consumption

530 W (Max); < 0.5 W (Standby)

Mechanical

Weight

9.4 Kg (20.7 lbs)

Output terminals

RGB output

D-Sub 15-pin (female) x 1

HDMI output x 1

Audio signal output x 1

Speaker

(Stereo) 10 watt x 1

Control

RS-232 serial control

9 pin x 1

LAN control

RJ45 x 1

IR receiver x 2

Wired Remote control x 1

12V Trigger power supply 12V / 0.5A x 1

Input terminals

Computer input

RGB input

D-Sub 15-pin (female) x 1

Video signal input

S-VIDEO

Mini DIN 4-pin port x 1

VIDEO

RCA jack x 1

Analog

Component RCA jack x 3 (through RGB input)

Digital

HDMI (1.4a, HDCP 1.4) x 3

Audio signal input

RCA audio jack (L/R) x 2

PC audio jack x 1

USB

Mini Type B x 1; Type-A power supply 5V / 2 A x 1

HDBaseT RX x 1

Environmental Requirements

Operating temperature

0°C–40°C at sea level

Storage temperature

-20°C–60°C at sea level

Operating/Storage relative humidity

10%–90% (without condensation)

Operating altitude

0–1499 m at 0°C–35°C

1500–3000 m at 0°C–30°C (with

High Altitude Mode on)

Dimensions

490 mm (W) x 159 mm (H) x 380 mm (D)

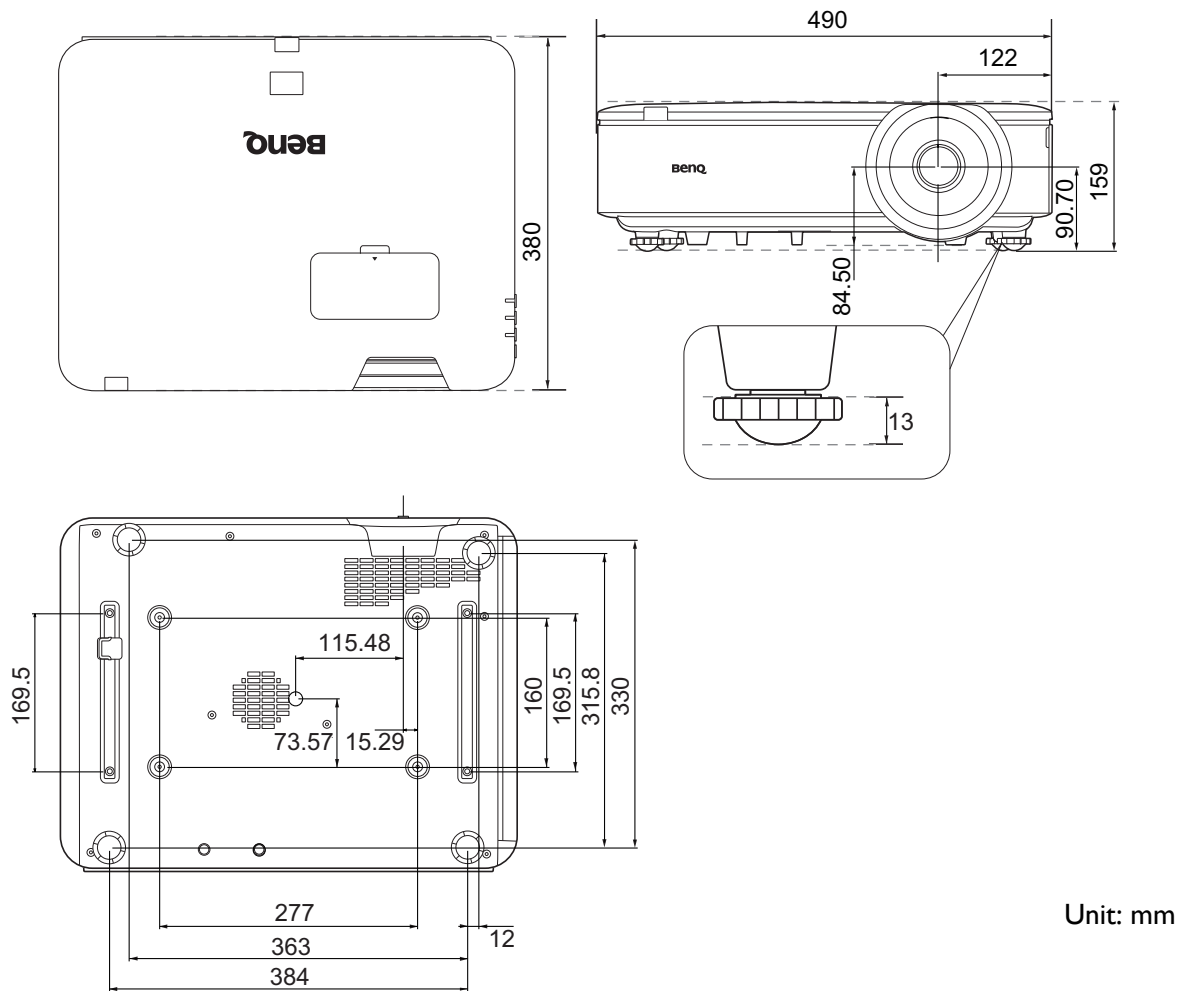

Unit: mm

Ceiling mount installation diagram

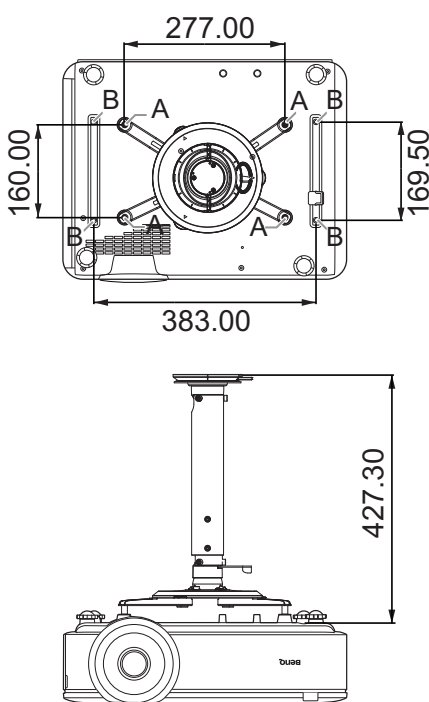

A: BenQ ceiling mount CMG3 (5J.JAM10.001)

Ceiling mount screw: M4
(Max. L = 25 mm; Min. L = 20 mm)

B: Third party mounting holes
Screw: M6 (Max. L = 8 mm)

Unit: mm

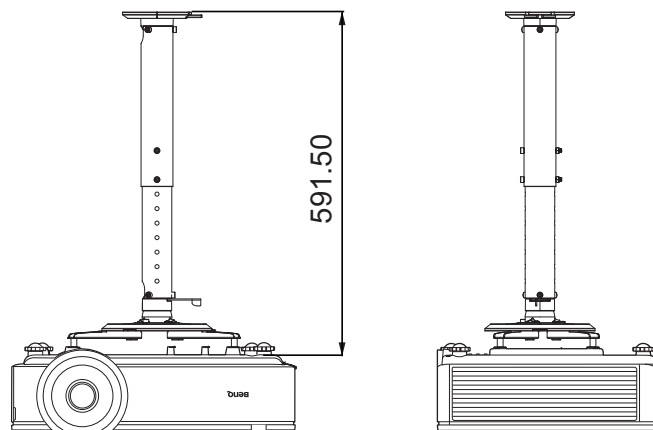

Timing chart

Supported timing for PC input

| Resolution | Mode | Vertical Frequency (Hz) | Horizontal Frequency (kHz) | Pixel Frequency (MHz) | Supported 3D format | | |
|------------------|----------------------------------|-------------------------|----------------------------|-----------------------|---------------------|------------|--------------|
| | | | | | Frame Sequential | Top Bottom | Side by Side |
| 640 x 480 | VGA_60 | 59.940 | 31.469 | 25.175 | V | V | V |
| | VGA_72 | 72.809 | 37.861 | 31.500 | | | |
| | VGA_75 | 75.000 | 37.500 | 31.500 | | | |
| | VGA_85 | 85.008 | 43.269 | 36.000 | | | |
| 720 x 400 | 720 x 400_70 | 70.087 | 31.469 | 28.3221 | | | |
| 800 x 600 | SVGA_60 | 60.317 | 37.879 | 40.000 | V | V | V |
| | SVGA_72 | 72.188 | 48.077 | 50.000 | | | |
| | SVGA_75 | 75.000 | 46.875 | 49.500 | | | |
| | SVGA_85 | 85.061 | 53.674 | 56.250 | | | |
| | SVGA_120 (Reduce Blanking) | 119.854 | 77.425 | 83.000 | V | | |
| 1024 x 768 | XGA_60 | 60.004 | 48.363 | 65.000 | V | V | V |
| | XGA_70 | 70.069 | 56.476 | 75.000 | | | |
| | XGA_75 | 75.029 | 60.023 | 78.750 | | | |
| | XGA_85 | 84.997 | 68.667 | 94.500 | | | |
| | XGA_120 (Reduce Blanking) | 119.989 | 97.551 | 115.5 | V | | |
| 1152 x 864 | 1152 x 864_75 | 75 | 67.5 | 108 | | | |
| 1024 x 576 | BenQ Notebook_timing | 60.0 | 35.820 | 46.966 | | | |
| 1024 x 600 | BenQ Notebook_timing | 64.995 | 41.467 | 51.419 | | | |
| 1280 x 720 | 1280 x 720_60 | 60 | 45.000 | 74.250 | V | V | V |
| 1280 x 768 | 1280 x 768_60 | 59.87 | 47.776 | 79.5 | V | V | V |
| 1280 x 800 | WXGA_60 | 59.810 | 49.702 | 83.500 | V | V | V |
| | WXGA_75 | 74.934 | 62.795 | 106.500 | | | |
| | WXGA_85 | 84.880 | 71.554 | 122.500 | | | |
| | WXGA_120 (Reduce Blanking) | 119.909 | 101.563 | 146.25 | V | | |
| 1280 x 1024 | SXGA_60 | 60.020 | 63.981 | 108.000 | | V | V |
| | SXGA_75 | 75.025 | 79.976 | 135.000 | | | |
| | SXGA_85 | 85.024 | 91.146 | 157.500 | | | |
| 1280 x 960 | 1280 x 960_60 | 60.000 | 60.000 | 108.000 | | V | V |
| | 1280 x 960_85 | 85.002 | 85.938 | 148.500 | | | |
| 1360 x 768 | 1360 x 768_60 | 60.015 | 47.712 | 85.5 | | V | V |
| 1400 x 1050 | SXGA+_60 | 59.978 | 65.317 | 121.750 | | V | V |
| 1440 x 900 | WXGA+_60 | 59.887 | 55.935 | 106.500 | | V | V |
| 1600 x 1200 | UXGA | 60.000 | 75.000 | 162.000 | | V | V |
| 1680 x 1050 | 1680 x 1050_60 | 59.954 | 65.290 | 146.250 | | V | V |
| 640 x 480@67Hz | MAC13 | 66.667 | 35.000 | 30.240 | | | |
| 832 x 624@75Hz | MAC16 | 74.546 | 49.722 | 57.280 | | | |
| 1024 x 768@75Hz | MAC19 | 74.93 | 60.241 | 80.000 | | | |
| 1152 x 870@75Hz | MAC21 | 75.060 | 68.680 | 100.000 | | | |
| 1920 x 1080@60Hz | 1920 x 1080_60 | 60 | 67.5 | 148.5 | | V | V |
| 1920 x 1200 | 1920 x 1200_60 (Reduce Blanking) | 59.950 | 74.038 | 154.0000 | | V | V |



The timings showing above may not be supported due to EDID file and VGA graphic card limitations. It is possible that some timings cannot be chosen.

Supported timing for HDMI (HDCP) input

- PC timings

| Resolution | Mode | Vertical Frequency (Hz) | Horizontal Frequency (kHz) | Pixel Frequency (MHz) | Supported 3D format | | |
|------------------|----------------------------------|-------------------------|----------------------------|-----------------------|---------------------|------------|--------------|
| | | | | | Frame Sequential | Top Bottom | Side by Side |
| 640 x 480 | VGA_60 | 59.940 | 31.469 | 25.175 | V | V | V |
| | VGA_72 | 72.809 | 37.861 | 31.500 | | | |
| | VGA_75 | 75.000 | 37.500 | 31.500 | | | |
| | VGA_85 | 85.008 | 43.269 | 36.000 | | | |
| 720 x 400 | 720 x 400_70 | 70.087 | 31.469 | 28.3221 | | | |
| 800 x 600 | SVGA_60 | 60.317 | 37.879 | 40.000 | V | V | V |
| | SVGA_72 | 72.188 | 48.077 | 50.000 | | | |
| | SVGA_75 | 75.000 | 46.875 | 49.500 | | | |
| | SVGA_85 | 85.061 | 53.674 | 56.250 | | | |
| 1024 x 768 | SVGA_120 (Reduce Blanking) | 119.854 | 77.425 | 83.000 | V | | |
| | XGA_60 | 60.004 | 48.363 | 65.000 | V | V | V |
| | XGA_70 | 70.069 | 56.476 | 75.000 | | | |
| | XGA_75 | 75.029 | 60.023 | 78.750 | | | |
| 1152 x 864 | XGA_85 | 84.997 | 68.667 | 94.500 | | | |
| | XGA_120 (Reduce Blanking) | 119.989 | 97.551 | 115.5 | V | | |
| 1152 x 864 | 1152 x 864_75 | 75 | 67.5 | 108 | | | |
| 1024 x 576@60Hz | BenQ Notebook Timing | 60.00 | 35.820 | 46.996 | | | |
| 1024 x 600@65Hz | BenQ Notebook Timing | 64.995 | 41.467 | 51.419 | | | |
| 1280 x 720 | 1280 x 720_60 | 60 | 45.000 | 74.250 | V | V | V |
| 1280 x 768 | 1280 x 768_60 | 59.870 | 47.776 | 79.5 | V | V | V |
| 1280 x 800 | WXGA_60 | 59.810 | 49.702 | 83.500 | V | V | V |
| | WXGA_75 | 74.934 | 62.795 | 106.500 | | | |
| | WXGA_85 | 84.880 | 71.554 | 122.500 | | | |
| | WXGA_120 (Reduce Blanking) | 119.909 | 101.563 | 146.25 | V | | |
| 1280 x 1024 | SXGA_60 | 60.020 | 63.981 | 108.000 | | V | V |
| | SXGA_75 | 75.025 | 79.976 | 135.000 | | | |
| | SXGA_85 | 85.024 | 91.146 | 157.500 | | | |
| 1280 x 960 | 1280 x 960_60 | 60.000 | 60.000 | 108 | | V | V |
| | 1280 x 960_85 | 85.002 | 85.938 | 148.500 | | | |
| 1360 x 768 | 1360 x 768_60 | 60.015 | 47.712 | 85.500 | | V | V |
| 1440 x 900 | WXGA+_60 | 59.887 | 55.935 | 106.500 | | V | V |
| 1400 x 1050 | SXGA+_60 | 59.978 | 65.317 | 121.750 | | V | V |
| 1600 x 1200 | UXGA | 60.000 | 75.000 | 162.000 | | V | V |
| 1680 x 1050 | 1680 x 1050_60 | 59.954 | 65.290 | 146.250 | | V | V |
| 640 x 480@67Hz | MAC13 | 66.667 | 35.000 | 30.240 | | | |
| 832 x 624@75Hz | MAC16 | 74.546 | 49.722 | 57.280 | | | |
| 1024 x 768@75Hz | MAC19 | 75.020 | 60.241 | 80.000 | | | |
| 1152 x 870@75Hz | MAC21 | 75.06 | 68.68 | 100.00 | | | |
| 1920 x 1080@60Hz | 1920 x 1080_60 | 60 | 67.5 | 148.5 | | V | V |
| 1920 x 1200 | 1920 x 1200_60 (Reduce Blanking) | 59.950 | 74.038 | 154.0000 | | V | V |



The timings showing above may not be supported due to EDID file and VGA graphic card limitations. It is possible that some timings cannot be chosen.

- Video timings

| Timing | Resolution | Vertical Frequency (Hz) | Horizontal Frequency (kHz) | Pixel Frequency (MHz) | Supported 3D format | | | |
|----------|-------------|-------------------------|----------------------------|-----------------------|---------------------|---------------|------------|--------------|
| | | | | | Frame Sequential | Frame Packing | Top Bottom | Side by Side |
| 480i | 720 x 480 | 59.94 | 15.73 | 27 | ✓ | | | |
| 480p | 720 x 480 | 59.94 | 31.47 | 27 | ✓ | | | |
| 576i | 720 x 576 | 50 | 15.63 | 27 | | | | |
| 576p | 720 x 576 | 50 | 31.25 | 27 | | | | |
| 720/50p | 1280 x 720 | 50 | 37.5 | 74.25 | | ✓ | ✓ | ✓ |
| 720/60p | 1280 x 720 | 60 | 45.00 | 74.25 | ✓ | ✓ | ✓ | ✓ |
| 1080/24P | 1920 x 1080 | 24 | 27 | 74.25 | | ✓ | ✓ | ✓ |
| 1080/25P | 1920 x 1080 | 25 | 28.13 | 74.25 | | | | |
| 1080/30P | 1920 x 1080 | 30 | 33.75 | 74.25 | | | | |
| 1080/50i | 1920 x 1080 | 50 | 28.13 | 74.25 | | | | ✓ |
| 1080/60i | 1920 x 1080 | 60 | 33.75 | 74.25 | | | | ✓ |
| 1080/50P | 1920 x 1080 | 50 | 56.25 | 148.5 | | | ✓ | ✓ |
| 1080/60P | 1920 x 1080 | 60 | 67.5 | 148.5 | | | ✓ | ✓ |

Supported timing for HDBaseT input

- PC timings

| Resolution | Mode | Vertical Frequency (Hz) | Horizontal Frequency (kHz) | Pixel Frequency (MHz) | Supported 3D format | | |
|------------------|----------------------------------|-------------------------|----------------------------|-----------------------|---------------------|------------|--------------|
| | | | | | Frame Sequential | Top Bottom | Side by Side |
| 640 x 480 | VGA_60 | 59.940 | 31.469 | 25.175 | V | V | V |
| | VGA_72 | 72.809 | 37.861 | 31.500 | | | |
| | VGA_75 | 75.000 | 37.500 | 31.500 | | | |
| | VGA_85 | 85.008 | 43.269 | 36.000 | | | |
| 720 x 400 | 720 x 400_70 | 70.087 | 31.469 | 28.3221 | | | |
| 800 x 600 | SVGA_60 | 60.317 | 37.879 | 40.000 | V | V | V |
| | SVGA_72 | 72.188 | 48.077 | 50.000 | | | |
| | SVGA_75 | 75.000 | 46.875 | 49.500 | | | |
| | SVGA_85 | 85.061 | 53.674 | 56.250 | | | |
| | SVGA_120 (Reduce Blanking) | 119.854 | 77.425 | 83.000 | V | | |
| 1024 x 768 | XGA_60 | 60.004 | 48.363 | 65.000 | V | V | V |
| | XGA_70 | 70.069 | 56.476 | 75.000 | | | |
| | XGA_75 | 75.029 | 60.023 | 78.750 | | | |
| | XGA_85 | 84.997 | 68.667 | 94.500 | | | |
| | XGA_120 (Reduce Blanking) | 119.989 | 97.551 | 115.5 | V | | |
| 1152 x 864 | 1152 x 864_75 | 75 | 67.5 | 108 | | | |
| 1024 x 576@60Hz | BenQ Notebook Timing | 60.00 | 35.820 | 46.996 | | | |
| 1024 x 600@65Hz | BenQ Notebook Timing | 64.995 | 41.467 | 51.419 | | | |
| 1280 x 720 | 1280 x 720_60 | 60 | 45.000 | 74.250 | V | V | V |
| 1280 x 768 | 1280 x 768_60 | 59.870 | 47.776 | 79.5 | V | V | V |
| 1280 x 800 | WXGA_60 | 59.810 | 49.702 | 83.500 | V | V | V |
| | WXGA_75 | 74.934 | 62.795 | 106.500 | | | |
| | WXGA_85 | 84.880 | 71.554 | 122.500 | | | |
| | WXGA_120 (Reduce Blanking) | 119.909 | 101.563 | 146.25 | V | | |
| | | | | | | | |
| 1280 x 1024 | SXGA_60 | 60.020 | 63.981 | 108.000 | | V | V |
| | SXGA_75 | 75.025 | 79.976 | 135.000 | | | |
| | SXGA_85 | 85.024 | 91.146 | 157.500 | | | |
| 1280 x 960 | 1280 x 960_60 | 60.000 | 60.000 | 108 | | V | V |
| | 1280 x 960_85 | 85.002 | 85.938 | 148.500 | | | |
| 1360 x 768 | 1360 x 768_60 | 60.015 | 47.712 | 85.500 | | V | V |
| 1440 x 900 | WXGA+_60 | 59.887 | 55.935 | 106.500 | | V | V |
| 1400 x 1050 | SXGA+_60 | 59.978 | 65.317 | 121.750 | | V | V |
| 1600 x 1200 | UXGA | 60.000 | 75.000 | 162.000 | | V | V |
| 1680 x 1050 | 1680 x 1050_60 | 59.954 | 65.290 | 146.250 | | V | V |
| 640 x 480@67Hz | MAC13 | 66.667 | 35.000 | 30.240 | | | |
| 832 x 624@75Hz | MAC16 | 74.546 | 49.722 | 57.280 | | | |
| 1024 x 768@75Hz | MAC19 | 75.020 | 60.241 | 80.000 | | | |
| 1152 x 870@75Hz | MAC21 | 75.06 | 68.68 | 100.00 | | | |
| 1920 x 1080@60Hz | 1920 x 1080_60 | 60 | 67.5 | 148.5 | | V | V |
| 1920 x 1200 | 1920 x 1200_60 (Reduce Blanking) | 59.950 | 74.038 | 154.0000 | | V | V |



The timings showing above may not be supported due to EDID file and VGA graphic card limitations. It is possible that some timings cannot be chosen.

• Video timings

| Timing | Resolution | Vertical Frequency (Hz) | Horizontal Frequency (kHz) | Pixel Frequency (MHz) | Supported 3D format | | | |
|----------|-------------|-------------------------|----------------------------|-----------------------|---------------------|---------------|------------|--------------|
| | | | | | Frame Sequential | Frame Packing | Top Bottom | Side by Side |
| 480i | 720 x 480 | 59.94 | 15.73 | 27 | V | | | |
| 480p | 720 x 480 | 59.94 | 31.47 | 27 | V | | | |
| 576i | 720 x 576 | 50 | 15.63 | 27 | | | | |
| 576p | 720 x 576 | 50 | 31.25 | 27 | | | | |
| 720/50p | 1280 x 720 | 50 | 37.5 | 74.25 | | V | V | V |
| 720/60p | 1280 x 720 | 60 | 45.00 | 74.25 | V | V | V | V |
| 1080/24P | 1920 x 1080 | 24 | 27 | 74.25 | | V | V | V |
| 1080/25P | 1920 x 1080 | 25 | 28.13 | 74.25 | | | | |
| 1080/30P | 1920 x 1080 | 30 | 33.75 | 74.25 | | | | |
| 1080/50i | 1920 x 1080 | 50 | 28.13 | 74.25 | | | | V |
| 1080/60i | 1920 x 1080 | 60 | 33.75 | 74.25 | | | | V |
| 1080/50P | 1920 x 1080 | 50 | 56.25 | 148.5 | | | V | V |
| 1080/60P | 1920 x 1080 | 60 | 67.5 | 148.5 | | | V | V |

Supported timing for Video and S-Video inputs

| Video mode | Horizontal Frequency (kHz) | Vertical Frequency (Hz) | Color sub-carrier Frequency (MHz) | Supported 3D format |
|------------|----------------------------|-------------------------|-----------------------------------|---------------------|
| | | | | Frame Sequential |
| NTSC | 15.73 | 60 | 3.58 | V |
| PAL | 15.63 | 50 | 4.43 | |
| SECAM | 15.63 | 50 | 4.25 or 4.41 | |
| PAL-M | 15.73 | 60 | 3.58 | |
| PAL-N | 15.63 | 50 | 3.58 | |
| PAL-60 | 15.73 | 60 | 4.43 | |
| NTSC4.43 | 15.73 | 60 | 4.43 | |

RS232 command

RS232 pin assignment

| No. | Serial |
|-----|--------|
| 1 | NC |
| 2 | RX |
| 3 | TX |
| 4 | NC |
| 5 | GND |

| No. | Serial |
|-----|--------|
| 6 | NC |
| 7 | RTSZ |
| 8 | CTSZ |
| 9 | NC |

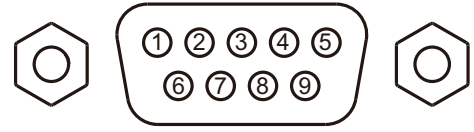

| Function | Type | Operation | ASCII |
|---------------------|-------|---------------------------|--------------------------|
| Power | Write | Power On | <CR>*pow=on#<CR> |
| | Write | Power off | <CR>*pow=off#<CR> |
| | Read | Power Status | <CR>*pow=?#<CR> |
| Source Selection | Write | COMPUTER/YPbPr | <CR>*sour=RGB#<CR> |
| | Write | HDMI | <CR>*sour=hdm1#<CR> |
| | Write | HDMI 2 | <CR>*sour=hdm2#<CR> |
| | Write | HDMI 3 | <CR>*sour=hdm3#<CR> |
| | Write | Composite | <CR>*sour=vid#<CR> |
| | Write | S-Video | <CR>*sour=svid#<CR> |
| | Write | HDbaseT | <CR>*sour=hdbaset#<CR> |
| | Read | Current source | <CR>*sour=?#<CR> |
| Audio Control | Write | Mute On | <CR>*mute=on#<CR> |
| | Write | Mute Off | <CR>*mute=off#<CR> |
| | Read | Mute Status | <CR>*mute=?#<CR> |
| | Write | Volume + | <CR>*vol=+#<CR> |
| | Write | Volume - | <CR>*vol=-#<CR> |
| | Write | Volume level for customer | <CR>*vol=value#<CR> |
| | Read | Volume Status | <CR>*vol=?#<CR> |
| Audio source select | Write | Audio pass Through off | <CR>*audiosour=off#<CR> |
| | Write | Audio-Computer1 | <CR>*audiosour=RGB#<CR> |
| | Write | Audio-Video/S-Video | <CR>*audiosour=vid#<CR> |
| | Write | Audio-HDMI | <CR>*audiosour=hdm1#<CR> |
| | Write | Audio-HDMI2 | <CR>*audiosour=hdm2#<CR> |
| | Write | Audio-HDMI3 | <CR>*audiosour=hdm3#<CR> |
| | Read | Audio pass Status | <CR>*audiosour=?#<CR> |
| Picture Mode | Write | Presentation | <CR>*appmod=preset#<CR> |
| | Write | sRGB | <CR>*appmod=srgb#<CR> |
| | Write | Bright | <CR>*appmod=bright#<CR> |
| | Write | DICOM | <CR>*appmod=dicom#<CR> |
| | Write | Vivid | <CR>*appmod=vivid#<CR> |
| | Write | User1 | <CR>*appmod=user1#<CR> |
| | Write | User2 | <CR>*appmod=user2#<CR> |
| | Write | 3D | <CR>*appmod=threed#<CR> |
| | Read | Picture Mode | <CR>*appmod=?#<CR> |

| Function | Type | Operation | ASCII |
|--------------------|------------------|----------------------------------|---------------------------|
| Picture Setting | Write | Contrast + | <CR>*con=+#<CR> |
| | Write | Contrast - | <CR>*con=#<CR> |
| | Read | Contrast value | <CR>*con=?#<CR> |
| | Write | Brightness + | <CR>*bri=+#<CR> |
| | Write | Brightness - | <CR>*bri=#<CR> |
| | Read | Brightness value | <CR>*bri=?#<CR> |
| | Write | Color + | <CR>*color=+#<CR> |
| | Write | Color - | <CR>*color=#<CR> |
| | Read | Color value | <CR>*color=?#<CR> |
| | Write | Sharpness + | <CR>*sharp=+#<CR> |
| | Write | Sharpness - | <CR>*sharp=#<CR> |
| | Read | Sharpness value | <CR>*sharp=?#<CR> |
| | Write | Color Temperature-Warm | <CR>*ct=warm#<CR> |
| | Write | Color Temperature-Normal | <CR>*ct=normal#<CR> |
| | Write | Color Temperature-Cool | <CR>*ct=cool#<CR> |
| | Read | Color Temperature Status | <CR>*ct=?#<CR> |
| | Write | Aspect 4:3 | <CR>*asp=4:3#<CR> |
| | Write | Aspect 16:9 | <CR>*asp=16:9#<CR> |
| | Write | Aspect 16:10 | <CR>*asp=16:10#<CR> |
| | Write | Aspect Auto | <CR>*asp=AUTO#<CR> |
| Write | Aspect Real | <CR>*asp=REAL#<CR> | |
| Read | Aspect Status | <CR>*asp=?#<CR> | |
| Write | Digital Zoom In | <CR>*zoomI#<CR> | |
| Write | Digital Zoom out | <CR>*zoomO#<CR> | |
| Write | Auto | <CR>*auto#<CR> | |
| Brilliant Color | Write | Brilliant color on | <CR>*BC=on#<CR> |
| | Write | Brilliant color off | <CR>*BC=off#<CR> |
| | Read | Brilliant color status | <CR>*BC=?#<CR> |
| Operation Settings | Write | Projector Position-Front Table | <CR>*pp=FT#<CR> |
| | Write | Projector Position-Rear Table | <CR>*pp=RE#<CR> |
| | Write | Projector Position-Rear Ceiling | <CR>*pp=RC#<CR> |
| | Write | Projector Position-Front Ceiling | <CR>*pp=FC#<CR> |
| | Write | Quick auto search | <CR>*QAS=on#<CR> |
| | Write | Quick auto search | <CR>*QAS=off#<CR> |
| | Read | Quick auto search status | <CR>*QAS=?#<CR> |
| | Read | Projector Position Status | <CR>*pp=?#<CR> |
| | Write | Direct Power On-on | <CR>*directpower=on#<CR> |
| | Write | Direct Power On-off | <CR>*directpower=off#<CR> |
| | Read | Direct Power On-Status | <CR>*directpower=?#<CR> |
| | Write | Signal Power On-on | <CR>*autopower=on#<CR> |
| | Write | Signal Power On-off | <CR>*autopower=off#<CR> |
| | Read | Signal Power On-Status | <CR>*autopower=?#<CR> |
| | Write | Standby Settings-Network on | <CR>*standbynet=on#<CR> |
| | Write | Standby Settings-Network off | <CR>*standbynet=off#<CR> |
| | Read | Standby Settings-Network Status | <CR>*standbynet=?#<CR> |
| | Write | Standby Settings-Monitor Out on | <CR>*standbymnt=on#<CR> |
| | Write | Standby Settings-Monitor Out off | <CR>*standbymnt=off#<CR> |
| | Read | Standby Settings-Monitor Out | <CR>*standbymnt=?#<CR> |

| Function | Type | Operation | ASCII |
|---------------|-------|------------------------------------|----------------------------|
| Baud Rate | Write | 9600 | <CR>*baud=9600#<CR> |
| | Write | 14400 | <CR>*baud=14400#<CR> |
| | Write | 19200 | <CR>*baud=19200#<CR> |
| | Write | 38400 | <CR>*baud=38400#<CR> |
| | Write | 57600 | <CR>*baud=57600#<CR> |
| | Write | 115200 | <CR>*baud=115200#<CR> |
| | Read | Current Baud Rate | <CR>*baud=?#<CR> |
| Lamp Control | Read | Lamp hour | <CR>*ltim=?#<CR> |
| | Write | Normal mode | <CR>*lampm=lnor#<CR> |
| | Write | Eco mode | <CR>*lampm=eco#<CR> |
| | Write | Dimming mode | <CR>*lampm=dimming#<CR> |
| | Write | Custom mode | <CR>*lampm=custom#<CR> |
| | Write | Light level for custom mode | <CR>*lampcustom=value#<CR> |
| | Read | Light level status for custom mode | <CR>*lampcustom=?#<CR> |
| | Read | Lamp Mode Status | <CR>*lampm=?#<CR> |
| Miscellaneous | Read | Model Name | <CR>*modelName=?#<CR> |
| | Write | Blank On | <CR>*blank=on#<CR> |
| | Write | Blank Off | <CR>*blank=off#<CR> |
| | Read | Blank Status | <CR>*blank=?#<CR> |
| | Write | Freeze On | <CR>*freeze=on#<CR> |
| | Write | Freeze Off | <CR>*freeze=off#<CR> |
| | Read | Freeze Status | <CR>*freeze=?#<CR> |
| | Write | Menu On | <CR>*menu=on#<CR> |
| | Write | Menu Off | <CR>*menu=off#<CR> |
| | Write | Up | <CR>*up#<CR> |
| | Write | Down | <CR>*down#<CR> |
| | Write | Right | <CR>*right#<CR> |
| | Write | Left | <CR>*left#<CR> |
| | Write | Enter | <CR>*enter#<CR> |
| | Write | 3D Sync Off | <CR>*3d=off#<CR> |
| | Write | 3D Auto | <CR>*3d=auto#<CR> |
| | Write | 3D Sync Top Bottom | <CR>*3d=tb#<CR> |
| | Write | 3D Sync Frame Sequential | <CR>*3d=fs#<CR> |
| | Write | 3D Frame packing | <CR>*3d=fp#<CR> |
| | Write | 3D Side by side | <CR>*3d=sbs#<CR> |
| | Write | 3D inverter disable | <CR>*3d=da#<CR> |
| | Write | 3D inverter | <CR>*3d=iv#<CR> |
| | Read | 3D Sync Status | <CR>*3d=?#<CR> |
| | Write | Remote Receiver-front+rear | <CR>*rr=f#<CR> |
| | Write | Remote Receiver-front | <CR>*rr=f#<CR> |
| | Write | Remote Receiver-rear | <CR>*rr=r#<CR> |
| | Read | Remote Receiver Status | <CR>*rr=?#<CR> |
| | Write | AMX Device Discovery-on | <CR>*amxdd=on#<CR> |
| | Write | AMX Device Discovery-off | <CR>*amxdd=off#<CR> |
| | Read | AMX Device Discovery Status | <CR>*amxdd=?#<CR> |
| | Read | Mac Address | <CR>*macaddr=?#<CR> |
| | Write | High Altitude mode on | <CR>*Highaltitude=on#<CR> |
| | Write | High Altitude mode off | <CR>*Highaltitude=off#<CR> |
| | Read | High Altitude mode status | <CR>*Highaltitude=?#<CR> |