



# Boekel Microplate Incubator

Model  
260700 & 260700-2

## Operating Instructions

## Table of Contents

1.0	Safety .....	3
2.0	Product Information .....	4
3.0	Assembly.....	4
3.1	Unpacking the Unit .....	4
3.2	Installation .....	4
4.0	Operation .....	4
4.1	Identification of Controls (See Figure 1 and Figure 2) .....	4
4.2	Temperature Adjustment.....	4
4.3	Temperature Indication .....	5
5.0	Technical Specifications.....	5
6.0	Fault Diagnosis.....	6
7.0	Maintenance and Service .....	6
7.1	Cleaning.....	6
8.0	Warranty .....	6
9.0	Service .....	7

Figure 1  
Front Panel

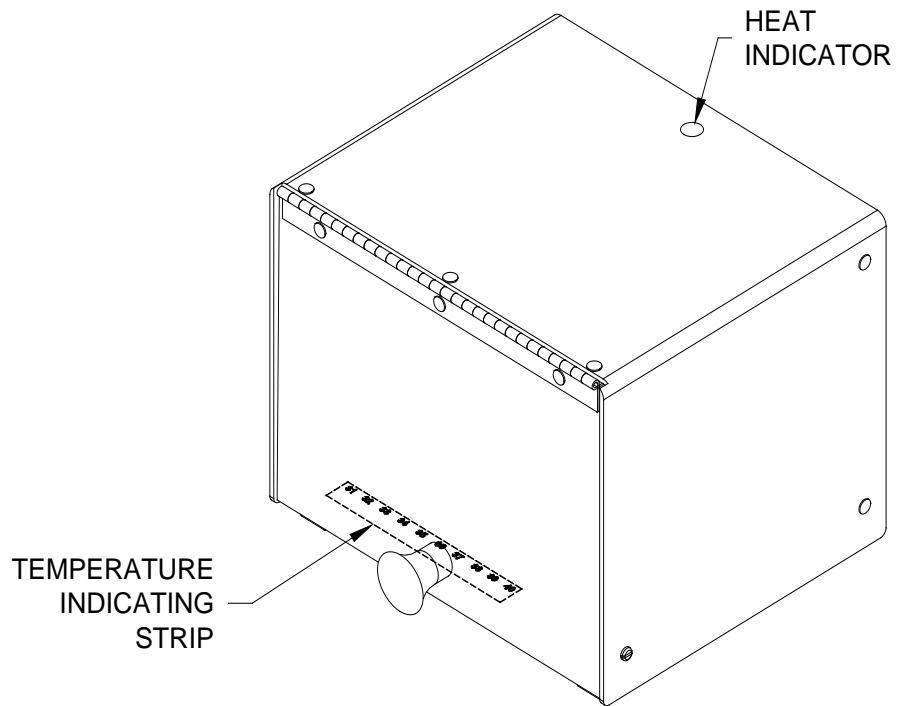
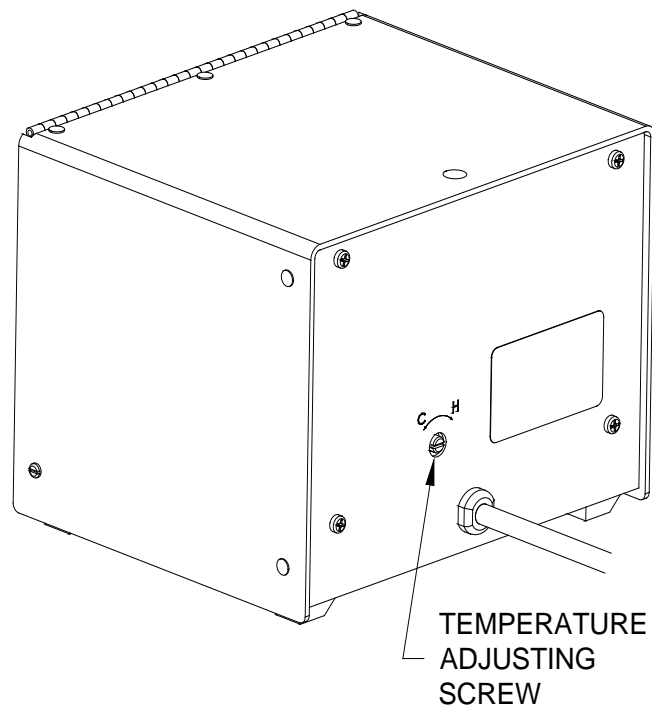

Figure 2  
Rear of Unit



## 1.0 Safety

### The following symbols marked on the equipment mean:



**Caution:** Read these operating instructions fully before use and pay particular attention to sections containing this symbol.

**Attention:** Suivre attentivement les instructions avant l'usage et prêtez une attention particulière aux sections comportant ce symbole.



**Caution:** Surfaces can become hot during use.

**Attention:** Les surfaces peuvent devenir brûlantes pendant l'usage.

Always observe the following safety precautions:

- Use only as specified by the operating instructions or the intrinsic protection may be impaired. After transport or storage in humid conditions, dry out the unit before connecting it to the supply voltage. During drying out the intrinsic protection may be impaired.
- Position unit to easily access power outlet in case of emergency.
- Connect only to a power supply that provides a safety ground terminal.
- **WARNING:** Do not use near volatile materials, fluids or combustible gasses.
- **WARNING:** Do not place volatile or combustible material into this incubator.
- **CAUTION:** This unit is not intended for use with flammable liquids or vapors.
- Do not touch surfaces that become hot during high temperature operation.
- Ensure that the operating temperature is less than the maximum operating temperature of your sample material.
- If liquid is spilled inside the unit, disconnect it from the power supply and have it checked by a competent person.
- It is the user's responsibility to carry out the appropriate decontamination if hazardous material is spilled on or inside the equipment.
- **Warning:** 115V units must be plugged into circuit with 15A breaker. 230V units must be plugged into circuit with 10A breaker.

## 2.0 Product Information

The Boekel Microplate Incubator is designed with the heating element located behind the back panel to reduce the risk of baking samples placed on the incubator bottom. Uses of this product include incubation of microplates, culture kits, petri dishes and test tubes. The operating temperature can be adjusted from ambient plus 5°C to 42°C. The incubator has a smoked acrylic door and a flat plastic Digitemp strip attached to the interior floor for temperature indication.

## 3.0 Assembly

### 3.1 Unpacking the Unit

Remove the packing materials carefully, and retain for future shipment or storage of the unit. Inspect for damage. Report all shipping damage to the carrier immediately. Shipping damage is covered by the carrier and repair/replacement for shipping damages must be coordinated through the carrier. Complete and return the Warranty Registration Card. Packages should contain:

- Microplate Incubator
- Operating Instructions

### 3.2 Installation

Place the incubator on a flat and stable surface, preferably away from drafts. Plug the power line cord into a grounded power outlet.

## 4.0 Operation

### 4.1 Identification of Controls (See Figure 1 and Figure 2)

The Heat Indicator is on continuously while the oven is heating up. As the required temperature is approached, it starts to flash. When the unit is controlling at the set temperature, the heater lamp flashes intermittently.

The Temperature Indicating Strip shows the chamber temperature in degrees Celsius.

The Temperature Adjusting Screw is used to adjust the chamber temperature.

### 4.2 Temperature Adjustment

The incubator has been preset to operate at 37°C. To adjust the temperature of the incubator, locate the temperature adjusting screw on the back of the unit. Turn the screw clockwise (as viewed from the back) to increase the temperature and counterclockwise

to decrease the temperature. Allow at least 15 minutes for the temperature to equilibrate after making an adjustment.

#### 4.3 Temperature Indication

A temperature indicator strip is located on the floor of the incubator cavity. To determine the temperature of the cavity use the following steps:

- a. Identify the number on the temperature indicator strip which is most brightly illuminated.
- b. Observe the color of the identified number and determine the temperature value according to the following instructions:  
Tan: Subtract 1°C from illuminated value  
Blue: Add 1°C to the illuminated value  
Bright Green: Read as indicated

### 5.0 Technical Specifications

This equipment is for indoor use and will meet its performance figures within the ambient temperature range of 10°C to 35°C, with maximum relative humidity of 80% non-condensing. Installation category II (transient voltages). Pollution degree 2 in accordance with IEC 664. For operation at altitudes of up to 6500 feet.

Temperature Range	Ambient + 5°C to 42°C
Supply Ratings	Model 260700: 115 VAC, 0.24 A, 50/60 Hz Model 260700-2: 230 VAC, 0.13 A, 50/60 Hz
Power Rating	Model 260700: 28 W Model 260700-2: 30 W
Heating Rate	Ambient to 37°C in 20 minutes

## 6.0 Fault Diagnosis

Symptom	Possible Cause	Action Required
Unit does not operate	a. Unit not plugged into power supply b. Power supply failure	a. Plug in b. Check that other electrical appliances on the same circuit are working
Chamber temperature does not rise when expected	a. Temperature control circuit fault	a. Have unit checked by a competent service person
Temperature continues to rise when not expected	a. Temperature control circuit fault	a. Have unit checked by a competent service person

## 7.0 Maintenance and Service

All Boekel laboratory products are designed to comply with IEC1010-1. No routine maintenance is required. No user serviceable parts in this product.

### 7.1 Cleaning

Disengage power cord prior to cleaning. If a spill occurs, use appropriate clean-up procedures as required for radiation or biohazard control. The outer casing can be cleaned with a cloth dampened with water. Do not immerse the unit in water. Abrasive materials such as paper towels will scratch the door.

## 8.0 Warranty

When used in laboratory conditions and according to these operating instructions, Boekel warrants this product to be free of defective material and workmanship for a period of two years from the date of manufacture. The liability of Boekel for any defective equipment during the warranty period shall be limited to the repair of such equipment or replacement thereof without charge for parts or labor.

## 9.0 Service

It is required to obtain a Returned Material Authorization (RMA) number before any Boekel products are returned for any reason. A Decontamination Certificate must be completed, signed by the user, and returned to Boekel Scientific prior to receiving the RMA number. Please be sure to mark the outside of the returned goods package with this RMA number to ensure prompt handling

Boekel Scientific  
855 Pennsylvania Boulevard  
Feasterville, PA 19053  
Phone: (215) 396-8200 or (800) 336-6929  
Fax: (215) 396-8264  
e-mail: [boekel-info@boekelsci.com](mailto:boekel-info@boekelsci.com)