



**Experience easy.
No setup. No adjustments. No waste.**

BradyPrinter i5300 Industrial Label Printer

Seriously easy. Really.

When you're focused on efficiency, every process counts, including the steps it takes to print. So why not make it easier? With the BradyPrinter i5300 Industrial Label Printer, you get a smoother and more intuitive experience. Set up, store print jobs and print — easily — and let simplicity drive your efficiency.

- **No waste** — prints on the very first label to maximize material use and cut costs
- **Fast setup** — 20-second material changeovers and drop-lock-print technology
- **Precision** — excellent small-font sharpness and print placement on smaller labels
- **Time-saving features** — prints faster and pauses and resumes jobs if interrupted
- **On-printer label storage** — saves 1,000s of labels with overwrite protection to printer
- **Performance-plus construction** — ideal for printing both high-volume and high-mix jobs



BRADY

3000 RPM 18
QUEUE
Supply Jam
2-88509-102-109 REV C
2.000 x 0.332 in
1 / 26

BradyPrinter i5300

2-88509-102-109
2-88509-102-101 REV C
2-88509-102-100 REV C
2-88509-102-100 REV C
2-88509-102-099 REV C
2-88509-102-099 REV C
2-88509-102-098 REV C
2-88509-102-098 REV C
2-88509-102-097 REV C
2-88509-102-097 REV C

The right printer for the way you work

Automatically fine-tuned, simple and intuitive

Precision printing with 20-second material changeovers and zero waste



BradyPrinter i3300 Industrial Label Printer

Zero calibration, zero wasted labels. A no-fuss, midvolume industrial printer using revolutionary B30 / B33 drop-in ribbons and label rolls that change out in 20 seconds with no manual adjustments for energy, speed or sensor placement. Ideal for high-mix printing, the i3300 includes a built-in auto cutter and prints on a wide range of materials, including labels as small as 0.25 inches. So simple and intuitive, you'll wonder how you ever printed efficiently without it.

(300 dpi)



BradyPrinter i5300 Industrial Label Printer

Zero calibration, zero wasted labels, with higher-volume duty cycle and ultra-precise printing. Prints on a very wide range of B30 / B33 materials with exceptional accuracy on labels as small as 0.20 inches. For ultimate high-mix printing with 20-second no-adjustment material changeovers, built-in auto-cutting and optional save-to-printer job lists for a quick way to print commonly used labels, and overwrite-protected labels away from the PC. When you're focused on efficiency, every process counts — let simplicity drive your productivity.

(300 dpi or 600 dpi)

Manually fine-tuned and technical

Customize printing one setting at a time and use specialty print modes



BradyPrinter i5100 Industrial Label Printer

Mid-volume printer that detects installed Brady parts, advises how to set the sensor and provides auto-setup in Brady software. Its enhanced communication makes high-mix labeling faster and more intuitive. Prints on a wide range of materials including labels as small as 0.20 inches. An optional auto-cut model is available.
(300 dpi or 600 dpi)



BradyPrinter i7100 Industrial Label Printer

Both heavy-duty and precise, here's a printer that can go the distance. It prints on a very wide range of materials, including labels as small as 0.125 inches. Printing and setup are manually fine-tuned and optional auto-peel, internal rewind and autocut models are available.
(300 dpi or 600 dpi)

Printer Options



Catalog

151290	BradyPrinter i5300, 300 dpi, Wi-Fi, Brady Workstation PWID Software Suite
151291	BradyPrinter i5300, 300 dpi, Wi-Fi, Brady Workstation Lab ID Software Suite
151292	BradyPrinter i5300, 300 dpi, Wi-Fi, Brady Workstation SFID Software Suite
151293	BradyPrinter i5300, 300 dpi, Wi-Fi, Brady Workstation GHS Labels Software
151294	BradyPrinter i5300, 600 dpi, Wi-Fi, Brady Workstation PWID Software Suite
151295	BradyPrinter i5300, 600 dpi, Wi-Fi, Brady Workstation Lab ID Software Suite
153710	BradyPrinter i5300, 600 dpi, Wi-Fi, Brady Workstation SFID Software Suite
153711	BradyPrinter i5300, 600 dpi, Wi-Fi, Brady Workstation GHS Labels Software

The above part number descriptions do not reflect complete product data — refer to the specification sheet for complete details.
i5300 printers accept all B30 / B33 series version V2 media.

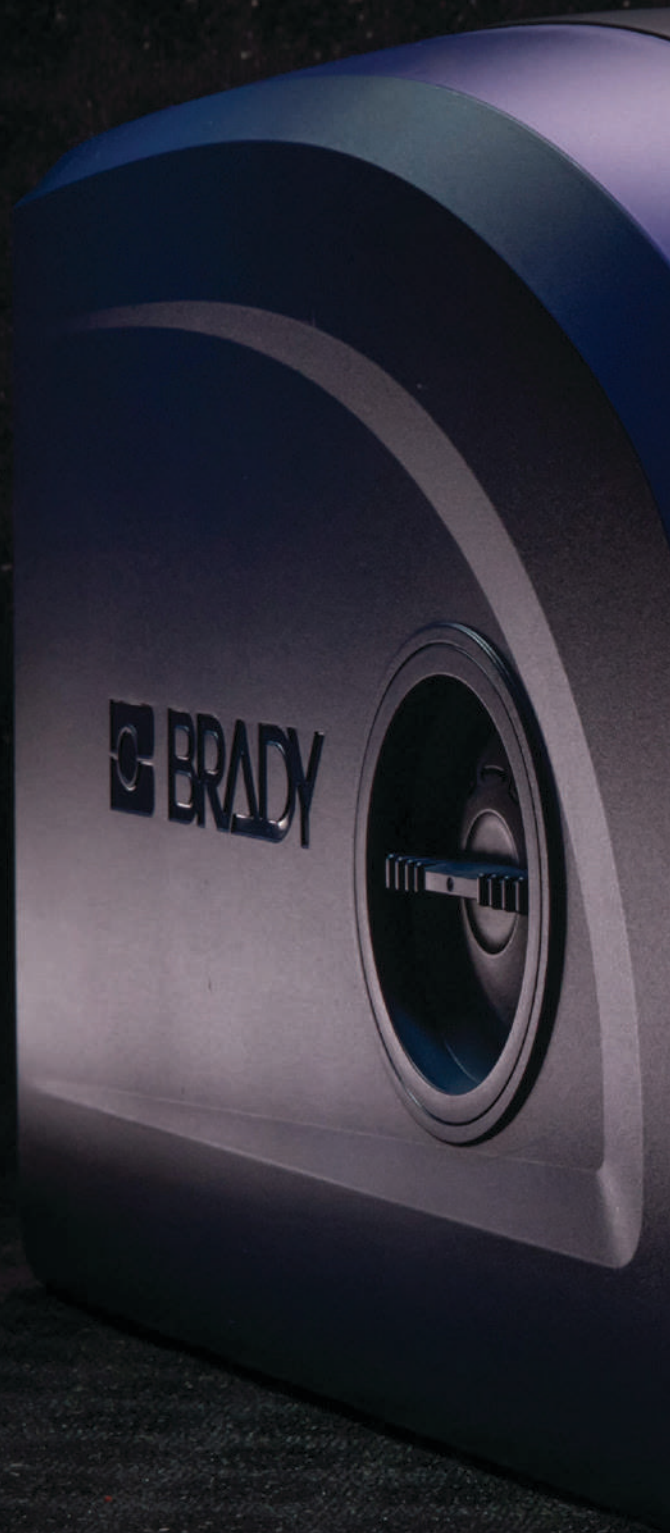



BradyPrinter i5300

Key features



No wasted labels — prints on the first one

No calibration is required, so there are no wasted labels and no trial and error during setup.

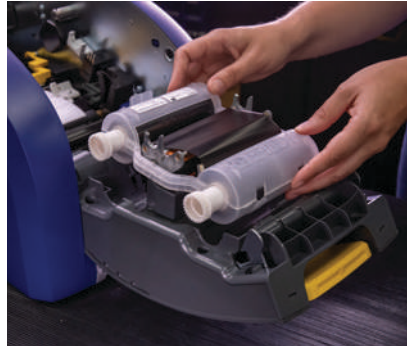

20-second supply changeovers

There are no sensor, heat or speed adjustments. Just drop, lock and print to reduce setup time.

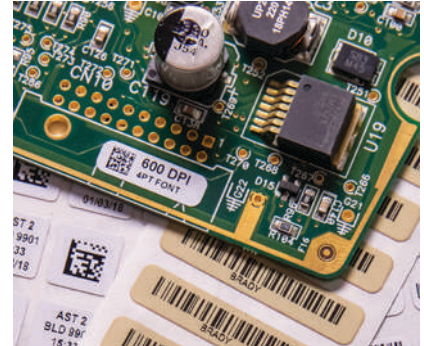

300- and 600-dpi print-resolution models

Prints small fonts with excellent precision and accuracy for electronics, product and laboratory identification.



1-click label part recognition and setup

Software, printer and materials communicate to allow 1-click auto setup of labels.



Faster print speeds for all job sizes

Get efficient, large-job printing with better performance and higher throughput.



Rugged construction for mid to high volumes

Metal-frame construction and internal print engine are designed for high performance.

BradyPrinter i5300

Industrial Label Printer

Easy. Inside and out.

When it comes to the BradyPrinter i5300 Industrial Label Printer, everything's easy. Taking just seconds to set up and load, it offers a faster, easier start-to-print process. That's because it's designed for efficiency — no setup, no adjustments and no waste. Zero. Enjoy time-saving features like a print queue and interrupt function. Plus, get precision printing on 1,300 parts. All this so you can reach your high-mix, high-volume printing goals. Ready? We told you it was going to be easy.

Rugged design

Solid construction with metal framing and gearing for higher throughput and workhorse durability

Built-in, programmable auto-cutter

Cuts off material after a job, after a label or not at all

Big 7" color touchscreen

Large icons are user-friendly and allow for faster navigation

Intuitive interface

Communicates installed part numbers, remaining supply, status, in-job navigation and label preview

Smart media rolls

PrintSmart Technology pre-optimizes speed, heat, size and ribbon / material-pairing settings, eliminating trial and error and wasted materials

Media guides and integrated sensors

Sensors automatically align when guides squeeze together — no adjustments, and no alignment trial and error

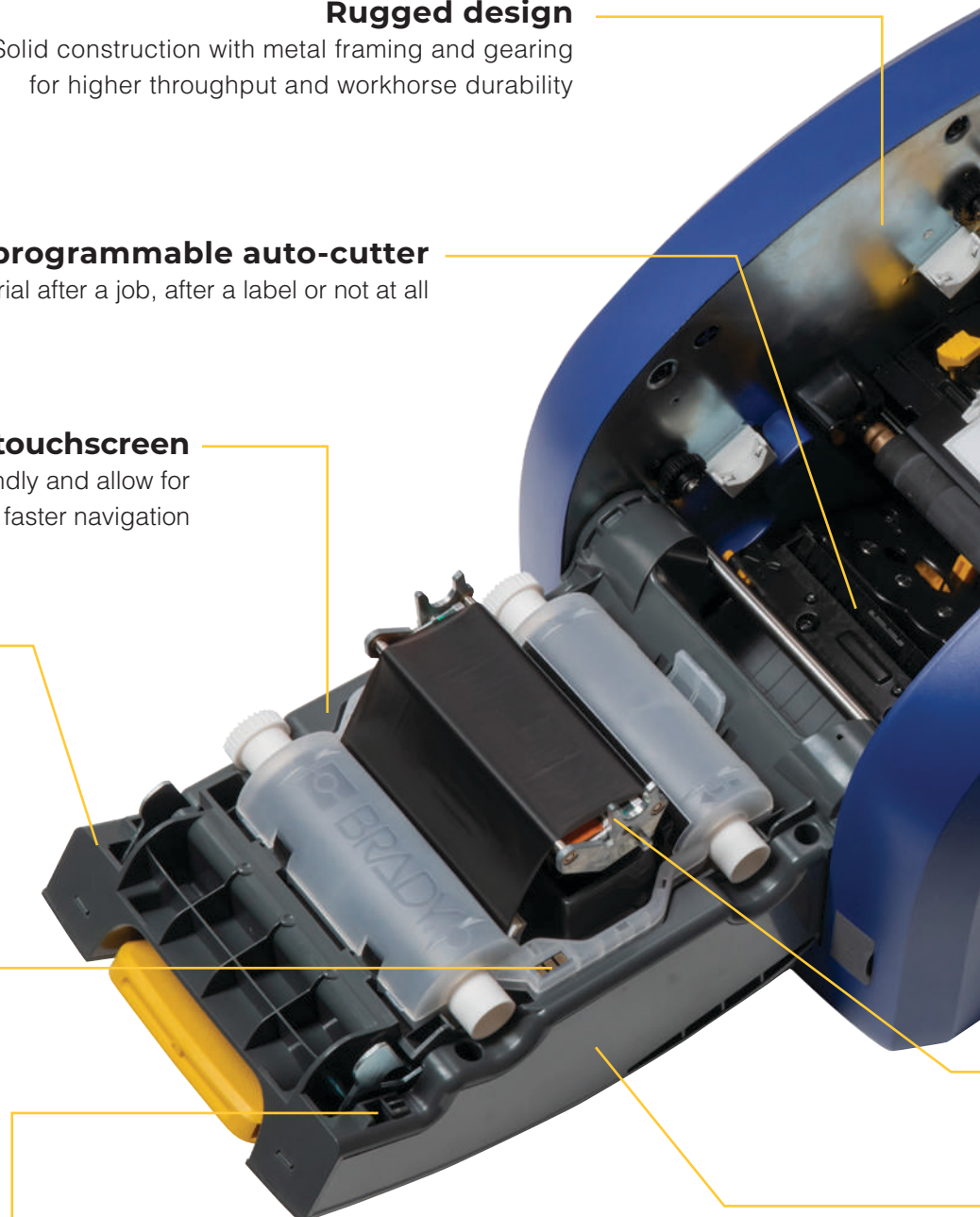



0.20" to 4" label widths

Prints small labels for electronics and laboratories, and also larger labels up to 4" wide

Easy loading; 20-second changeovers

Labels and ribbons drop in with no thread-through, orientation checks or wasted materials

Double-side wire sleeve printing

External feed slot and print app enable 2-pass printing for double-side heat-shrink sleeves

Fast print speed

Auto-set at 1 to 10 inches per second, but user-override allows for faster printing

Connectivity and ports

3 USB ports and Ethernet, with optional Wi-Fi / Bluetooth

Field-replaceable print roller

Easily replace a damaged or worn roller to ensure optimal print quality

Field-replaceable printhead

Tool-less printhead replacement using a single-release pin and connectors (replace with same dpi printhead only)

Print queue

Print immediately, store or customize the order in which jobs print

Making it happen

If you need innovation, we're here. With easier and more efficient solutions, your business can move ahead, going from better to its very best. Whether this means working with printers, software, materials or automation, our eyes are on your performance.

At Brady, we have a deep commitment to making places safer and more secure. And, after more than a century of experience, we believe we have succeeded. Our solutions are flexible and easily customizable. They're also built with durability in mind to help you accomplish even more than you thought was possible. Looking to the future, as you strive for a better work experience, just know we're with you every step of the way.

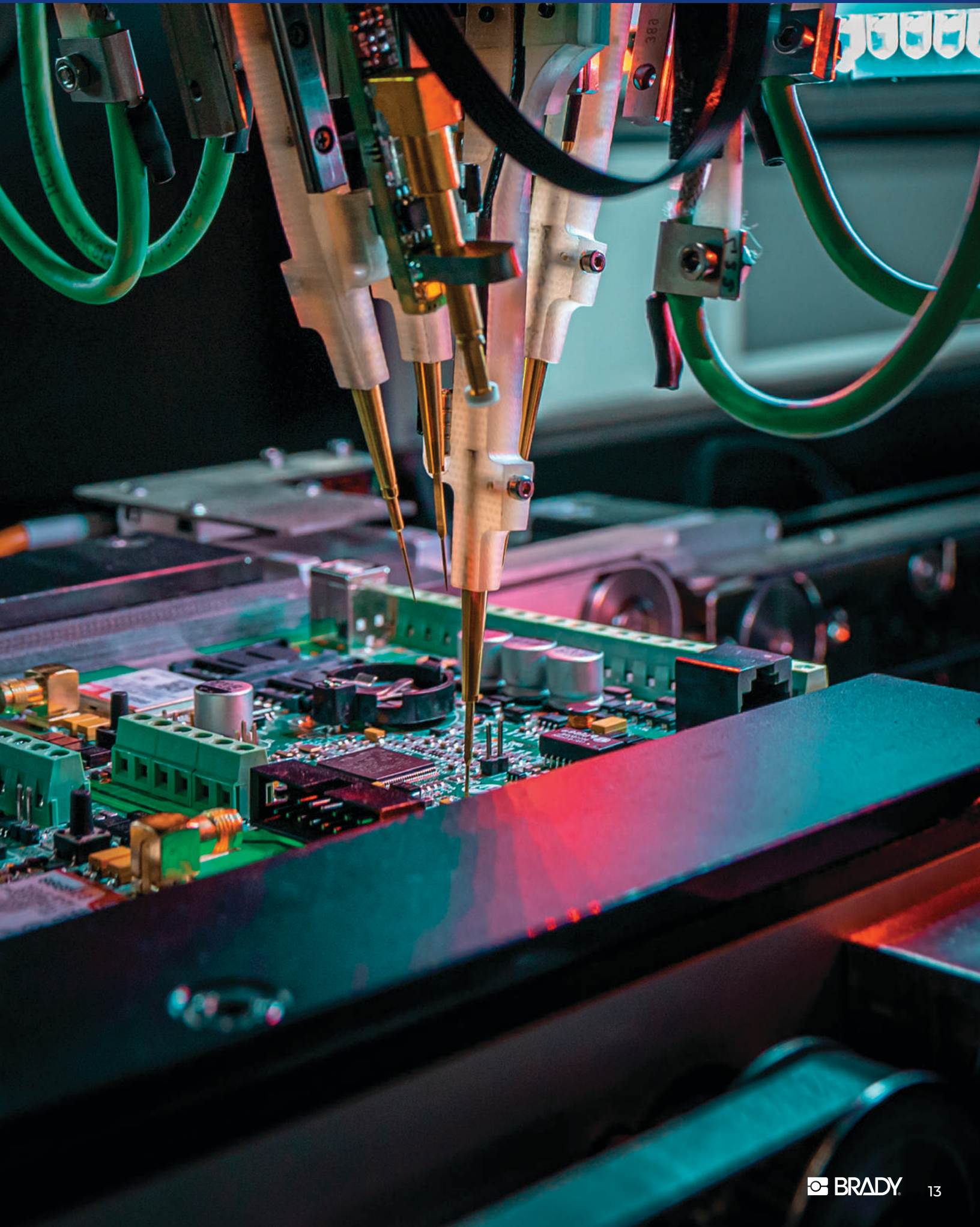



BRADY

BradyPrinter i5300

Part Y33401
2.2 Cambs - galvanized
Part Y33401
2.2 Cambs - galvanized
Part Y33401
2.2 Cambs - galvanized
Part Y33401
2.2 Cambs - galvanized
Part Y33401
2.2 Cambs - galvanized
Part Y33401
2.2 Cambs - galvanized
Part Y33401
2.2 Cambs - galvanized
Part Y33401
2.2 Cambs - galvanized



PERMASLEEVE 187
PERMASLEEVE 187
PERMASLEEVE 187
PERMASLEEVE 187
PERMASLEEVE 187
PERMASLEEVE 187
PERMASLEEVE 187

LOW
ON
LOW
VACUUM 2 ON
LOW

100 4469
100 4470
100 4470
100 4468
100 4468
100 4469
100 4466
100 4467
100 4467
100 4465
100 4466

2463 R
2463 R
2463 R
2463 R
2463 R
2461 R
2461 R
2461 R
2461 R
2461 R
2461 R
2462 R
2462 R
2462 R
2462 R
2462 R
2462 R
2460 R
2460 R
2460 R
2460 R
2460 R
2460 R
2458 R
2458 R
2458 R
2458 R
2458 R
2456 R
2456 R
2456 R
2456 R

LEGAS TO LINE A

N45 STUDY
05 JUL 2021 17:23 TAG
SAMPLE 20 OF 60
N45 STUDY
05 JUL 2021 17:23 TAG
SAMPLE 21 OF 60
N45 STUDY
05 JUL 2021 17:23 TAG
SAMPLE 19 OF 60
N45 STUDY
05 JUL 2021 17:23 TAG
SAMPLE 18 OF 60
N45 STUDY
05 JUL 2021 17:23 TAG
SAMPLE 17 OF 60
N45 STUDY
05 JUL 2021 17:23 TAG
SAMPLE 16 OF 60
N45 STUDY
05 JUL 2021 17:23 TAG
SAMPLE 15 OF 60
N45 STUDY
05 JUL 2021 17:23 TAG
SAMPLE 14 OF 60
N45 STUDY
05 JUL 2021 17:23 TAG
SAMPLE 13 OF 60
N45 STUDY
05 JUL 2021 17:23 TAG
SAMPLE 12 OF 60

Going the distance

At Brady, we go the distance to make sure you get what you need. Whether it's field work or lab work, we've got materials for every application.

Barcodes, images, small text — your most important information needs to stay put in any type of environment. From freezing temperatures to blistering heat, when used with solvents or in outer space, simply put, Brady materials are all about high performance. Our scientists make sure of it. Brady's R&D program focuses on solutions that bring durability, flexibility and efficiency to every workday.

We offer hundreds of labels, so be sure to browse through the entire collection. And, as always, let us know if you need more.



Materials for every application

Successful projects start (and end) with Brady materials. Optimum performance and durability are assured with each.

			Color	Permanent	Removable	Matte	Gloss	Service Temperature	Regulations	Page #
B-342	PermaSleeve® Heat-Shrink Sleeves	Heat-shrinkable polyolefin wire and cable marking sleeve with a 3:1 shrink ratio. Fade-resistant and flame-retardant industrial, military grade sleeve.		•		•		-67° to 275°F		44, 45
B-344	PermaSleeve® Fluid Resistant Heat-Shrink Sleeves	Heat-shrinkable, fluid-resistant polyolefin wire and cable marking sleeve with a 2:1 shrink ratio. Designed for exposure to fluids, lubricants and harsh chemicals such as in the installation of hydrogen fuel cells in aerospace.		•		•		-67° to 275°F	RoHS	46
B-345	PermaSleeve® High Temp Heat-Shrink Sleeves	Heat-shrinkable, high-temperature PVDF wire and cable marking sleeve with a 3:1 shrink ratio. Designed for high-temperature and low-outgassing applications.		•		•		-67° to 437°F	RoHS	47
B-403	Water-Dissolvable Paper	White water-dissolvable paper label for temporary labeling applications that require easy cleaning. Ideal for laboratory glassware.		•		•		-94° to 122°F	RoHS	62
B-413	Matte Faux Metallized Polyester	Silver polyester label with a strong, permanent adhesive and a metal appearance, but NON-METAL construction. Adhesive designed for flat surfaces that are textured or require increased adhesion. Ideal for non-metal applications for PCB and component identification, rating plates and product labels.		•		•		-94° to 248°F		23, 28
B-414	BradyGrip® Print-on Hook Material Featuring VELCRO® Brand Hook	Printable hook label material that affixes to VELCRO® Brand ONE-WRAP® rolls (sold separately). Ideal for repositionable and reusable cable bundle markers.			•		•	-40° to 122°F	RoHS	41
B-417	High Adhesion Self-Laminating Vinyl	Translucent vinyl label with extra strong permanent adhesive. The adhesive is designed to adhere in high humidity conditions, on smaller diameter wires and on challenging wire jacket materials, including Teflon, Silicone, braided and traditional PVC. Self-laminating formats feature a white printable zone and a non-printable clear tail that wraps around a wire, cable or tube to cover the printed, text offering protection from abrasion, water, oil and solvents.		•		•		-94° to 158°F		40
B-422	High Adhesion Multi-Purpose Polyester	Polyester with a high-gloss finish and a stronger, 2-mil permanent acrylic adhesive. Adhesive is designed for flat surfaces that are textured or require increased adhesion. Ideal for barcoding, asset tracking, product labels and post-process PCB electronic component labeling.		•			•	-40° to 212°F		24, 39
B-423	Multi-Purpose Polyester	Polyester with a high-gloss finish and a permanent acrylic adhesive. Excellent image quality and widely used for barcoding, asset tracking, product labels and post-process PCB electronic component labeling. Adheres best to flat surfaces. UL-rated for surfaces commonly used in solar panel manufacturing.		•			•	-94° to 248°F		22
B-423/ B-966B	PermaShield™ Overlaminating Polyester	The PermaShield™ construction is supplied as a standard B-423 polyester label with matching B-966B clear polyester overlaminate mounted beneath the label. The label is printed, removed from liner and applied to surface, and then the overlaminate is removed and applied over the label protecting printed text.		•			•	-94° to 248°F	RoHS	31
B-424	Paper	Bright white paper label with a permanent latex adhesive. Excellent barcode read rates. Ideal for labeling applications requiring a low-cost, general-purpose labeling material.		•		•		-40° to 122°F	RoHS	32
B-425A	Chemical Resistant Matte Polypropylene	Polypropylene label with a permanent adhesive and excellent solvent resistance and print performance. Fuel-, oil-, chemical- and low-temperature resistant.		•		•		-94° to 212°F	RoHS	30, 55
B-427	Self-Laminating Vinyl	Translucent vinyl label with a permanent adhesive. Self-laminating format features a white printable zone and a non-printable clear tail that wraps around a wire, cable or tube to cover the printed text. Offers protection from abrasion, water, oil and solvents. Material conforms well to curved and rounded surfaces.		•		•		-94° to 158°F		40, 41
B-428	Metallized Matte Polyester	Matte metallized polyester with a permanent adhesive. Light gray, matte appearance. Adheres best to flat surfaces. Ideal for rating plates on products and panels, and general-purpose product labels.		•		•		-40° to 293°F		28
B-428/ B-966B	PermaShield™ Overlaminating Metallized Polyester	The PermaShield™ construction is supplied as a standard B-428 metallized polyester label with matching B-966B clear polyester overlaminate mounted beneath the label. The label is printed, removed from liner and applied to surface. Then the overlaminate is removed and applied over the label to protect printed text.		•		•		-40° to 293°F	RoHS	31
B-430	Multi-Purpose Clear Polyester	Clear polyester with a high-gloss finish and a 1-mil permanent acrylic adhesive. It has excellent image quality and adheres best to flat surfaces.		•			•	-40° to 293°F		23

For further ribbon compatibility related to UL / CSA, see pages 65-66 or refer to Brady Tech Data Sheet for complete material performance specifications

			Color	Permanent	Removable	Matte	Gloss	Service Temperature	Regulations	Page #
B-432	High Adhesion Multi-Purpose Clear Polyester	Clear polyester with a high-gloss finish and a stronger, 2-mil permanent acrylic adhesive. It has excellent imaging quality and is designed for flat surfaces that are textured or require increased adhesion.	⊘	•			•	-40° to 212°F	UL RoHS CE	24
B-434A	Metallized High Adhesion Polyester	Glossy metallized polyester with a stronger, 2-mil permanent adhesive. It has a high-gloss, silver appearance with excellent image quality. Adhesive is designed for flat surfaces that are textured or require increased adhesion. Ideal for rating plates, general-purpose product labels and asset tracking labels.	●	•			•	-40° to 194°F	UL RoHS CE	29, 38
B-435A	Metallized Polyester	Glossy metallized polyester with a 1-mil permanent adhesive. It has a high-gloss, silver appearance and excellent imaging quality. It adheres best to flat surfaces and is ideal for rating plates and general-purpose product labels.	●	•			•	-40° to 194°F	UL RoHS CE	28
B-437	Self-Extinguishing Tedlar®	Heavy-duty Tedlar® label material with self-extinguishing features for wire and cable wrapping. It has excellent resistance to water, oil, chemicals and abrasion.	○●	•		•		-94° to 275°F	RoHS	43
B-438	Checkerboard Pattern Tamper Evident Matte Metallized Polyester	Tamper-indicating, metallized polyester label that leaves an aggressive checkerboard adhesive pattern on the surface if label is removed. It has a matte, silver appearance with has excellent imaging quality for text, barcodes and symbols. It is designed for rating and serial plates, asset tracking labels and product ID such as warranty labels when anti-tampering and tamper-indicating features are desired.	●	•		•		-40° to 104°F	UL RoHS CE	30
B-439	Multi-Purpose Vinyl	Indoor- and outdoor-grade vinyl with a high-tack permanent adhesive. It is extremely pliable and highly conforming to rough and irregular surfaces, and has good chemical and abrasion resistance. Ideal for general-purpose labeling applications.	○	•			•	-94° to 176°F	RoHS	31, 58
B-443	High Adhesion Hi-Temp Self Extinguishing Matte Polyester	Very durable matte polyester with excellent high-temp resistance and superior resistance to fluids and chemicals that are not high in pH value. Short term temp resistance to 410° F. Features a hybrid acrylic-rubber-based permanent adhesive and is self-extinguishing.	○	•		•		-94° to 248° F	UL	27
B-461	Self-Laminating Cryogenic Polyester	Ultra-thin profile label with a white printable area and a clear self-laminating tail. The clear label protects print and allows visibility of liquid level in a vial. It has excellent smudge resistance and solvent resistance, and performs well in laboratory environments with liquid nitrogen, autoclave, freezer and hot water bath applications when laminated around itself.	⊘	•		•		-320° to 320°F check TDS for specific applications	RoHS	60
B-472	High Temp Flame Retardant Polyimide	Heavy-duty, high-temperature label designed to self-extinguish and prevent flames from propagating. This material is flexible, conforming and repositionable for wire and cable wrapping where high-temperature and self-extinguishing properties are required. Excellent resistance to water, oil, chemicals and abrasion.	○●	•		•		-94° to 320°F	RoHS	43
B-473	Electrostatic Dissipative Polyester	Glossy polyester label that is ideal for post-process labeling of circuit boards and electronic components. Features both a static dissipative permanent adhesive and a static dissipative release liner. Surface resistivity values are in the recommended range for ESD packing materials. Meets requirement of EIA-541 "Packaging Material Standards for ESD Sensitive Items". This material is ideal for circuit board and component identification, and is fuel, oil, chemical, high- and low-temperature resistant.	○	•			•	-40° to 248°F	UL RoHS CE	27
B-481	StainerBondz™ Microscope Slide Polyester	Designed as a label for microscope slides that are exposed to laboratory staining processes. This material is chemical resistant.	○	•		•		-112° to 266°F	RoHS	59, 62
B-483A	Ultra High Adhesion Multi-Purpose Polyester	Polyester with high-gloss finish and ultra-aggressive, permanent acrylic adhesive. Designed for very high adhesion to flat but highly textured or powder-coated surfaces and low-surface-energy surfaces. Gloss version of B-489.	○	•			•	-40° to 248°F	UL RoHS CE	25, 38, 39, 59
B-484A	Flexible High Adhesion Multi-Purpose Polyester	Polyester with a glossy finish and a stronger, permanent acrylic adhesive. Similar to B-483, but with a thinner construction to facilitate high adhesion to flat, curved or angular surfaces, and surfaces that are textured, powder coated or low-surface energy.	○	•			•	-40° to 248°F	UL RoHS	24, 39
B-486B	Ultra High Adhesion Metallized Matte Polyester	Matte metallized polyester with an ultra-aggressive, permanent adhesive. It has a light gray, matte appearance. Designed for very high adhesion to flat but highly textured or powder-coated surfaces and low-surface-energy surfaces. Ideal for panel rating plates, product labels and asset-tracking labels.	●	•		•		-40° to 248°F	UL RoHS CE	29, 38
B-489A	Ultra High Adhesion Multi-Purpose Matte Polyester	Matte polyester with an ultra-aggressive, permanent adhesive. It is designed for very high adhesion to flat but highly textured or powder-coated surfaces and low-surface-energy surfaces. Matte version of B-483.	○	•		•		-94° to 248°F	UL RoHS CE	25
B-490	FreezerBondz™ Cryogenic Polyester	FreezerBondz™ material is designed for use in laboratory identification, including liquid nitrogen and freezer applications. Adheres to room-temperature, frozen or frosted tubes and vials when wrapped around itself by at least 1/8 inch.	○	•		•		-320° to 320°F check TDS for specific applications	RoHS	60

For further ribbon compatibility related to UL / CSA, see pages 65-66 or refer to Brady Tech Data Sheet for complete material performance specifications

			Color	Permanent	Removable	Matte	Gloss	Service Temperature	Regulations	Page #
B-492	FreezerBondz™ Ultra-Thin Cryogenic Polyester	Ultra-thin FreezerBondz™ material is designed to withstand extreme laboratory temperatures, including liquid nitrogen and freezer applications. Adheres to room-temperature, frozen or frosted tubes, vials and canes.	○	•		•		-320° to 230°F check TDS for specific applications	RoHS	60
B-494	Colored Lab Polyester	Glossy white polyester with a pre-printed colored border. This material allows for differentiation and color coding of test specimens within processes. In vial and vial top configuration, the vial top label is a solid color. Withstands freezer applications and has superior chemical resistance when printed with the Brady Series R6400 black ribbon.		•			•	-320° to 158°F	RoHS	61
B-498	Repositionable Multi-Purpose Vinyl Cloth	Vinyl cloth with an aggressive and repositionable adhesive for wire and cable wraps and general-purpose labeling applications. Label adheres with excellent holding power, yet can be easily and cleanly removed and repositioned.	○		•		•	-40° to 175°F	UL RoHS	39, 42, 58
B-499	High Adhesion Multi-Purpose Nylon Cloth	Nylon cloth with a permanent adhesive for wire and cable wraps and general-purpose labeling applications. It has a higher upper-temperature limit than vinyl wire labels. Ideal for environments where heat, cold, oil and dirt are present. Also ideal for laboratory vial identification.	○	•			•	-40° to 230°F	UL RoHS CE	39, 42, 58, 61, 63
B-509	Magnetic Polyester (repositionable)	A thick, non-adhesive magnetic material with a printable vinyl topcoat. The easiest and quickest material for repositioning and reusing labels.	○ ●		•	•		-0° to 158°F	RoHS	56
B-526	BradyGlo™ High Intensity Glow-in-the-Dark Polyester	Printable BradyGlo™ photoluminescent polyester tape is for glow-in-the-dark identification for up to 10 hours. Ideal for marking emergency shut-offs and controls markings, supplemental evacuation labels and marking emergency equipment.	●	•			•	-40° to 140°F	RoHS	55
B-549	Cold Temperature Application Multi-Purpose Polyester	Cold-temperature polyester material permanently adheres to frozen surfaces. Can be applied in temperatures as low as -10°F, and stays adhered in -40°F temperatures.	○ ●	•		•		-40° to 212°F	RoHS	56
B-551	Heavy Duty Non-adhesive Tag Stock	A durable, non-adhesive plastic tag material. Ideal for safety and general-purpose industrial hang-tags, as well as lockout tagout applications.	○	n/a	n/a	•		-40° to 193°F	RoHS	51
B-569	Low-Halide Multi-Purpose Polyester	Low-halide polyester label material with a permanent adhesive. It is designed for stainless steel pipes and stainless steel surfaces, and is best suited for smooth, clean, flat surfaces.		•			•	-40° to 212°F	RoHS	53, 57
B-581	Repositionable Multi-Purpose Vinyl	Durable vinyl label with repositionable adhesive.	○ ●		•	•		-40° to 180°F	RoHS	56
B-584	All-Weather Reflective	Printable retroreflective tape. This is highly reflective material that shines back brightly when struck by light. Ideal for low-light and inclement-weather viewing applications.		•			•	-40° to 158°F	RoHS	55
B-593	Raised Profile Foam-backed Polyester	High-gloss polyester label with a thick, raised profile and an ultra-aggressive permanent adhesive. Designed as a high-performance low-cost alternative to engraved plates and push-button labels on panels and enclosures. Ideal for labeling small components inside panels.		•			•	-4° to 212°F	UL RoHS	36, 37, 39
B-595	All Weather Vinyl	Indoor- and outdoor-grade vinyl with a permanent adhesive in a wide range of colors. Durable, pliable and highly conforming to rough and irregular surfaces.		•			•	-40° to 180°F	RoHS	51, 52, 58, 63
B-618	Multi-Purpose Matte Polyester	Matte polyester for general-purpose applications requiring good solvent and heat resistance.	○	•		•		-94° to 248°F	UL RoHS	22
B-717	Electrostatic Dissipative Polyimide	Glossy 2-mil low-profile polyimide film with a permanent static dissipative adhesive and static dissipative release liner. Designed for use in circuit board and electronic component pre-process labeling. UL Recognized to UL969 standard for labeling and marking when printed with the Brady Series R6000 Halogen Free ribbon.	○	•			•	-94° to 572°F check TDS for temp duration details	UL RoHS	34
B-718	Ultra-Thin Electrostatic Dissipative Polyimide	Glossy 1-mil low-profile polyimide film with a permanent static dissipative adhesive and static dissipative release liner. It is designed to withstand the various processes, fluxes and cleaning solvents in the manufacture of printed circuit boards. UL Recognized to UL969 standard for labeling and marking when printed with the Brady Series R6000 Halogen Free ribbon.	○	•			•	-94° to 572°F check TDS for temp duration details	UL RoHS	34

For further ribbon compatibility related to UL / CSA, see pages 65-66 or refer to Brady Tech Data Sheet for complete material performance specifications

			Color	Permanent	Removable	Matte	Gloss	Service Temperature	Regulations	Page #
B-719	Ultra-Thin Matte Electrostatic Dissipative Matte Polyimide	Matte 1-mil low-profile polyimide film with a permanent static dissipative adhesive and static dissipative release liner. It is designed for circuit board and electronic component pre-process labeling. Matte topcoat provides excellent resistance to solder balling. UL Recognized to UL969 standard for labeling and marking when printed with the Brady Series R6000 Halogen Free and Series R4700 ribbons.	○	•		•		-94° to 572°F check TDS for temp duration details	UL RoHS ⚠	34
B-724	Ultra High Temp Matte Amber Polyimide	Extreme, high-temperature polyimide film with a permanent acrylic adhesive. It is designed to withstand the various processes, fluxes and cleaning solvents encountered in the manufacture of printed circuit boards. Can be used for top- or bottom-side component or board identification. Withstands extremely high temperatures.	●	•		•		-94° to 626°F check TDS for temp duration details	RoHS	35
B-727	High Temp Polyimide	Glossy polyimide film with a permanent acrylic adhesive. It is designed to withstand the various processes, fluxes and cleaning solvents encountered in the manufacture of printed circuit boards. Can be used for top- or bottom-side component or board identification. Glossy topcoat provides excellent contrast and smear resistance.	○	•			•	-94° to 572°F check TDS for temp duration detail	UL RoHS	33
B-728	High Temp Matte Polyimide	Matte polyimide film with a permanent acrylic adhesive. It is designed to withstand the various processes, fluxes and cleaning solvents encountered in the manufacture of printed circuit boards. Matte topcoat provides excellent resistance to solder balling. Can be used for top- or bottom-side component or board identification.	○	•		•		-94° to 572°F check TDS for temp duration details	UL RoHS	33
B-729	Ultra-Thin High Temp Matte Polyimide	Low profile matte polyimide label for pre-process circuit board identification.	○	•		•		-94° to 572°F check TDS for temp duration details	UL RoHS	33
B-7425	Chemical and Temperature Resistant Matte Polypropylene	Designed for laboratory applications that expose the label to liquid nitrogen, auto-clave and other harsh environments. Can be applied to both curved or flat surfaces.	○	•		•		-112° to 250°F check TDS for specific applications	RoHS	60, 61
B-7425-AC	Sterilization Indicating Autoclave Polypropylene	All-white polypropylene label with hidden text header that appears "STERILIZED" when exposed to autoclave conditions. Withstands extremely low and high lab temps making it ideal for sample tracking and labeling items that need to be sterilized.	○	•		•		-320.8° to 249.8°F check TDS for specific applications	RoHS	62
B-7569	General Purpose Vinyl	Durable vinyl label with permanent adhesive.	○	•			•	-4° to 167°F	RoHS	57, 63
B-7641	PermaSleeve® Low Smoke Zero Halogen Heat-Shrink Sleeve	Heat-shrinkable, low halogen polyolefin wire and cable marking sleeve with 2:1 shrink ratio. Offers excellent fire safety characteristics combined with minimal smoke emission. This material is abrasion resistant.	○ ●	•		•		-67° to 221°F	RoHS	48
B-7642	PermaSleeve® 2:1 Heat-Shrink Sleeve	Heat-shrinkable polyolefin wire and cable marking sleeve with a 2:1 shrink ratio. This material is high-temperature rated, highly flame retardant, and a very flexible industrial- and military-grade sleeve.	○	•		•		-40° to 248°F	RoHS	49
B-7643	Zero Halogen Polyurethane Tag Stock	Zero-halogen, non-adhesive polyurethane cable marker tag. Tags feature pre-cut holes in the corners to allow zip-tie fastening to a cable or wire harness bundle.	○ ●	n/a	n/a	•		-40° to 193°F	RoHS	50
B-777	Non-Reflow High Temp Polyimide	No-reflow, no-preheat polyimide label with a permanent adhesive. Ideal for boards that go through multiple harsh-condition washes.	○	•			•	-94° to 572°F check TDS for temp duration details	UL RoHS Ⓢ	35
B-8117	Multi-Purpose Matte Black Polyester	Matte black polyester label with a permanent adhesive for high heat and chemical resistance.	●	•		•		-112° to 248°F	UL RoHS	23, 38
B-813	Direct Thermal Paper	Direct thermal printable paper label with a permanent adhesive. This material does not require the use of a print ribbon. For use in i5300 printer only.	○	•		•		-40° to 140°F	RoHS	32
B-816	Removable Direct Thermal Paper	Direct thermal printable paper label with a removable adhesive. This material does not require the use of a print ribbon. For use in i5300 printer only.	○		•	•		-40° to 140°F	RoHS	32
B-854	ToughWash® Metal Detectable Washdown Resistant Polyester	Metal-detectable ToughWash® washdown-resistant label with a permanent adhesive. This material features a metal-detectable layer to allow detection in the food stream. Withstands numerous cycles of harsh chemicals, heat and heavy moisture.	○ ●	•		•		-40° to 230°F	RoHS	54
B-855	ToughWash® Washdown Resistant Polyester	ToughWash® washdown-resistant label with a permanent adhesive. Withstands numerous cycles of harsh chemicals, heat and heavy moisture. Abrasion, fuel, oil, chemical, high- and low-temperature resistant.	○ ●	•		•		-40° to 230°F	RoHS	54
B-8591	All-Weather Polyester	Outdoor durable polyester label for product, component and asset identification. Best for smooth surfaces.	○ ● ●	•			•	-94° to 266°F	UL (except silver) RoHS (all)	26, 28, 38

For further ribbon compatibility related to UL/CSA, see pages 65-66 or refer to Brady Tech Data Sheet for complete material performance specifications

Polyester Labels with Standard Adhesion (B-423, B-618, B-430, B-413, B-8117)

- For general purpose identification, product labels and post-process circuit board identification
- Adheres best to flat, smooth surfaces. Consult technical data sheet for UL / CSA ratings and complete performance and testing details

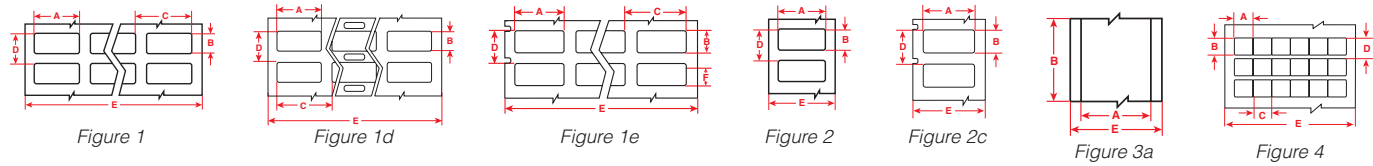
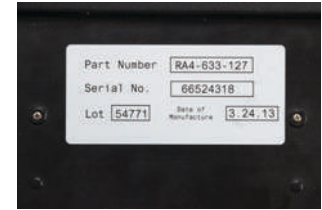

For Use with Printers:	Diagram	Catalog #	Color	Label width A inch (mm)	Label height B inch (mm)	Horiz. repeat C inch (mm)	Vert. repeat D inch (mm)	Web width E inch (mm)	Labels per row	Labels per roll	Rec. ribbon
Multi-purpose gloss polyester (B-423)											
i3300, i5300, BBP33	Fig. 1	B33-70-423	Gloss White	0.250 (6.4)	0.250 (6.4)	0.320 (8.1)	0.350 (8.9)	2.370 (60.1)	7	20000	B30-R6000
i3300, i5300, BBP33	Fig. 4	B33-11-423	Gloss White	0.250 (6.4)	0.250 (6.4)	0.250 (6.4)	0.375 (9.5)	3.200 (81.3)	12	15000	B30-R6000
i3300, i5300, BBP33	Fig. 1	B33-340-423	Gloss White	0.375 (9.5)	0.375 (9.5)	0.438 (11.1)	0.475 (12.1)	3.500 (88.9)	7	10000	B30-R6000
i5300	Fig. 1d	B33-343-423	Gloss White	0.500 (12.7)	0.200 (5.0)	0.625 (15.8)	0.325 (8.2)	3.200 (81.3)	5	10000	B30-R6000
i3300, i5300, BBP33	Fig. 1	B33-12-423	Gloss White	0.500 (12.7)	0.437 (11.0)	0.662 (16.8)	0.537 (13.6)	3.350 (85.1)	5	10000	B30-R6000
i3300, i5300, BBP33	Fig. 1	B33-149-423	Gloss White	0.500 (12.7)	0.500 (12.7)	0.600 (15.2)	0.600 (15.2)	2.500 (63.5)	4	5000	B30-R6000
i5300	Fig. 1d	B33-341-423	Gloss White	0.650 (16.5)	0.200 (5.0)	0.700 (17.7)	0.325 (8.2)	2.950 (74.9)	4	10000	B30-R6000
i3300, i5300, BBP33	Fig. 1	B33-1-423	Gloss White	0.750 (19.1)	0.250 (6.4)	0.800 (20.3)	0.350 (8.9)	3.350 (85.1)	4	5000	B30-R6000
i3300, i5300, BBP33	Fig. 2	B33-46-423	Gloss White	0.750 (19.1)	0.250 (6.4)	-	0.350 (8.9)	0.950 (24.1)	1	5000	B30-R6000
i3300, i5300, BBP33	Fig. 1	B33-2-423	Gloss White	0.900 (22.9)	0.250 (6.4)	1.125 (28.5)	0.350 (8.9)	3.350 (85.1)	3	10000	B30-R6000
i3300, i5300, BBP33	Fig. 2	B33-49-423	Gloss White	0.900 (22.9)	0.250 (6.4)	-	0.350 (8.9)	1.100 (27.9)	1	5000	B30-R6000
i3300, i5300, BBP33	Fig. 1	B33-51-423	Gloss White	1.000 (25.4)	0.250 (6.4)	1.075 (27.3)	0.350 (8.9)	3.350 (85.1)	3	10000	B30-R6000
i3300, i5300, BBP33	Fig. 2	B33-103-423	Gloss White	1.000 (25.4)	0.250 (6.4)	-	0.350 (8.9)	1.200 (30.5)	1	5000	B30-R6000
i3300, i5300, BBP33	Fig. 1	B33-3-423	Gloss White	1.000 (25.4)	0.375 (9.5)	1.075 (27.3)	0.475 (12.1)	3.350 (85.1)	3	5000	B30-R6000
i3300, i5300, BBP33	Fig. 1	B33-5-423	Gloss White	1.000 (25.4)	0.500 (12.7)	1.075 (27.3)	0.600 (15.2)	3.350 (85.1)	3	5000	B30-R6000
i3300, i5300, BBP33	Fig. 1	B33-13-423	Gloss White	1.250 (31.8)	0.250 (6.4)	1.300 (33.0)	0.375 (9.5)	2.750 (69.9)	2	7000	B30-R6000
i3300, i5300, BBP33	Fig. 2	B33-43-423	Gloss White	1.250 (31.8)	0.250 (6.4)	-	0.350 (8.9)	1.450 (36.8)	1	5000	B30-R6000
i3300, i5300, BBP33	Fig. 1	B33-29-423	Gloss White	1.250 (31.8)	0.375 (9.5)	1.300 (33.0)	0.475 (12.1)	2.750 (69.9)	2	5000	B30-R6000
i3300, i5300, BBP33	Fig. 1	B33-4-423	Gloss White	1.500 (38.1)	0.250 (6.4)	1.650 (41.9)	0.350 (8.9)	3.350 (85.1)	2	8000	B30-R6000
i3300, i5300, BBP33	Fig. 2	B33-45-423	Gloss White	1.500 (38.1)	0.250 (6.4)	-	0.350 (8.9)	1.700 (43.2)	1	5000	B30-R6000
i3300, i5300, BBP33	Fig. 1	B33-147-423	Gloss White	1.500 (38.1)	0.375 (9.5)	1.650 (41.9)	0.475 (12.1)	3.350 (85.1)	2	5000	B30-R6000
i3300, i5300, BBP33	Fig. 1	B33-37-423	Gloss White	1.500 (38.1)	0.500 (12.7)	1.650 (41.9)	0.600 (15.2)	3.350 (85.1)	2	5000	B30-R6000
i3300, i5300, BBP33	Fig. 1	B33-6-423	Gloss White	1.500 (38.1)	0.750 (19.1)	1.650 (41.9)	0.875 (22.2)	3.350 (85.1)	2	3300	B30-R6000
i3300, i5300, BBP33	Fig. 2	B33-72-423	Gloss White	1.750 (44.5)	0.250 (6.4)	-	0.350 (8.9)	1.950 (49.5)	1	5000	B30-R6000
i3300, i5300, BBP33	Fig. 2	B33-15-423	Gloss White	2.000 (50.8)	0.250 (6.4)	-	0.375 (9.5)	2.200 (55.9)	1	3200	B30-R6000
i3300, i5300, BBP33	Fig. 2	B33-53-423	Gloss White	2.000 (50.8)	0.500 (12.7)	-	0.600 (15.2)	2.200 (55.9)	1	2500	B30-R6000
i3300, i5300, BBP33	Fig. 2	B33-17-423	Gloss White	2.000 (50.8)	1.000 (25.4)	-	1.125 (28.6)	2.200 (55.9)	1	1500	B30-R6000
i3300, i5300, S3000, S3100, BBP30, BBP31, BBP33, BBP35, BBP37	Fig. 3a	B30C-2000-423	Gloss White	2.000 (50.8)	100 ft. (30.5 m)	-	-	2.250 (57.2)	1 roll (cont.)		B30-R6000
i3300, i5300, BBP33	Fig. 2	B33-7-423	Gloss White	2.750 (69.9)	1.250 (31.8)	-	1.375 (34.9)	2.950 (74.9)	1	1000	B30-R6000
i3300, i5300, BBP33	Fig. 2	B33-18-423	Gloss White	3.000 (76.2)	1.000 (25.4)	-	1.125 (28.6)	3.200 (81.3)	1	1500	B30-R6000
i3300, i5300, S3000, S3100, BBP30, BBP31, BBP33, BBP35, BBP37	Fig. 3a	B30C-3000-423	Gloss White	3.000 (76.2)	100 ft. (30.5 m)	-	-	3.250 (82.6)	1 roll (cont.)		B30-R6000
i3300, i5300, BBP33	Fig. 2	B33-19-423	Gloss White	3.000 (76.2)	2.000 (50.8)	-	2.125 (54.0)	3.200 (81.3)	1	500	B30-R6000
i3300, i5300, BBP33	Fig. 2	B33-20-423	Gloss White	3.000 (76.2)	5.000 (127.0)	-	5.125 (130.1)	3.200 (81.3)	1	350	B30-R6000
i3300, i5300, S3000, S3100, BBP30, BBP31, BBP33, BBP35, BBP37	Fig. 3a	B30C-4000-423	Gloss White	4.000 (101.6)	100 ft. (30.5 m)	-	-	4.200 (106.7)	1 roll (cont.)		B30-R6000
i3300, i5300, BBP33	Fig. 2	B33-55-423	Gloss White	4.000 (101.6)	2.000 (50.8)	-	2.125 (54.0)	4.200 (106.7)	1	750	B30-R6000
i3300, i5300, BBP33	Fig. 2	B33-76-423	Gloss White	4.000 (101.6)	3.000 (76.2)	-	3.125 (79.3)	4.200 (106.7)	1	500	B30-R6000
i3300, i5300, BBP33	Fig. 2	B33-161-423	Gloss White	4.000 (101.6)	4.000 (101.6)	-	4.125 (104.7)	4.200 (106.7)	1	450	B30-R6000
i3300, i5300, BBP33	Fig. 2	B33-25-423	Gloss White	4.000 (101.6)	6.000 (152.4)	-	6.125 (155.5)	4.200 (106.7)	1	300	B30-R6000
Multi-purpose matte polyester (B-618)											
i3300, i5300, BBP33	Fig. 1	B33-12-618	Matte White	0.500 (12.7)	0.437 (11.0)	0.662 (16.8)	0.537 (13.6)	3.350 (85.1)	5	10000	B30-R6000
i3300, i5300, BBP33	Fig. 1	B33-5-618	Matte White	1.000 (25.4)	0.500 (12.7)	1.075 (27.3)	0.600 (15.2)	3.350 (85.1)	3	7000	B30-R6000
i3300, i5300, BBP33	Fig. 1	B33-37-618	Matte White	1.500 (38.1)	0.500 (12.7)	1.650 (41.9)	0.600 (15.2)	3.350 (85.1)	2	5000	B30-R6000
i3300, i5300, BBP33	Fig. 1	B33-6-618	Matte White	1.500 (38.1)	0.750 (19.1)	1.650 (41.9)	0.875 (22.2)	3.350 (85.1)	2	3300	B30-R6000
i3300, i5300, BBP33	Fig. 2	B33-53-618	Matte White	2.000 (50.8)	0.500 (12.7)	-	0.600 (15.2)	2.200 (55.9)	1	2500	B30-R6000
i3300, i5300, BBP33	Fig. 2	B33-17-618	Matte White	2.000 (50.8)	1.000 (25.4)	-	1.125 (28.5)	2.200 (55.9)	1	1500	B30-R6000
i3300, i5300, BBP33	Fig. 2	B33-7-618	Matte White	2.750 (69.9)	1.250 (31.8)	-	1.375 (34.9)	2.950 (74.9)	1	1000	B30-R6000
i3300, i5300, BBP33	Fig. 2	B33-18-618	Matte White	3.000 (76.2)	1.000 (25.4)	-	1.125 (28.5)	3.350 (85.1)	1	1500	B30-R6000
i3300, i5300, BBP33	Fig. 2	B33-19-618	Matte White	3.000 (76.2)	2.000 (50.8)	-	2.125 (53.9)	3.200 (81.3)	1	700	B30-R6000
i3300, i5300, BBP33	Fig. 2	B33-55-618	Matte White	4.000 (101.6)	2.000 (50.8)	-	2.125 (53.9)	4.200 (106.7)	1	750	B30-R6000
i3300, i5300, BBP33	Fig. 2	B33-76-618	Matte White	4.000 (101.6)	3.000 (76.2)	-	3.125 (79.3)	4.200 (106.7)	1	500	B30-R6000

For Use with Printers:	Diagram	Catalog #	Color	Label width A inch (mm)	Label height B inch (mm)	Horiz. repeat C inch (mm)	Vert. repeat D inch (mm)	Web width E inch (mm)	Labels per row	Labels per roll	Rec. ribbon
Multi-purpose gloss clear polyester (B-430)											
i3300, i5300, BBP33	Fig. 1e	B33-12-430	Clear	0.500 (12.7)	0.437 (11.0)	0.662 (16.8)	0.537 (13.6)	3.350 (85.1)	5	10000	B30-R6000
i3300, i5300, BBP33	Fig. 1e	B33-5-430	Clear	1.000 (25.4)	0.500 (12.7)	1.075 (27.3)	0.625 (15.9)	3.350 (85.1)	3	5000	B30-R6000
i3300, i5300, BBP33	Fig. 1e	B33-37-430	Clear	1.500 (38.1)	0.500 (12.7)	1.650 (41.9)	0.600 (15.2)	3.350 (85.1)	2	5000	B30-R6000
i3300, i5300, BBP33	Fig. 1e	B33-6-430	Clear	1.500 (38.1)	0.750 (19.1)	1.650 (41.9)	0.875 (22.2)	3.350 (85.1)	2	3300	B30-R6000
i3300, i5300, BBP33	Fig. 2c	B33-53-430	Clear	2.000 (50.8)	0.500 (12.7)	-	0.600 (15.2)	2.200 (55.9)	1	2500	B30-R6000
i3300, i5300, BBP33	Fig. 2c	B33-17-430	Clear	2.000 (50.8)	1.000 (25.4)	-	1.125 (28.6)	2.200 (55.9)	1	1500	B30-R6000
i3300, i5300, BBP33	Fig. 2c	B33-7-430	Clear	2.750 (69.9)	1.250 (31.8)	-	1.375 (34.9)	2.950 (74.9)	1	1000	B30-R6000
i3300, i5300, BBP33	Fig. 2c	B33-18-430	Clear	3.000 (76.2)	1.000 (25.4)	-	1.125 (28.6)	3.200 (81.3)	1	1500	B30-R6000
i3300, i5300, BBP33	Fig. 3a	B33C-3000-430	Clear	3.000 (76.2)	100 ft. (30.5 m)	-	-	3.200 (81.3)	1 roll (cont.)		B30-R6000
i3300, i5300, BBP33	Fig. 2c	B33-19-430	Clear	3.000 (76.2)	2.000 (50.8)	-	2.125 (53.9)	3.200 (81.3)	1	700	B30-R6000
Multi-purpose matte black polyester (B-8117)											
i3300, i5300, BBP33	Fig. 1	B33-70-8117	Matte Black	0.250 (6.4)	0.250 (6.4)	0.320 (8.1)	0.350 (8.9)	2.370 (60.1)	7	20000	B30-R6800-WT
i3300, i5300, BBP33	Fig. 1	B33-12-8117	Matte Black	0.500 (12.7)	0.437 (11.0)	0.662 (16.8)	0.537 (13.6)	3.350 (85.1)	5	10000	B30-R6800-WT
i5300	Fig. 1d	B33-341-8117	Matte Black	0.650 (16.5)	0.200 (5.0)	0.700 (17.7)	0.325 (8.2)	2.950 (74.9)	4	10000	B30-R6800-WT
i3300, i5300, BBP33	Fig. 1	B33-1-8117	Matte Black	0.750 (19.1)	0.250 (6.4)	0.800 (20.3)	0.350 (8.9)	3.350 (85.1)	4	10000	B30-R6800-WT
i3300, i5300, BBP33	Fig. 1	B33-3-8117	Matte Black	1.000 (25.4)	0.375 (9.5)	1.075 (27.3)	0.475 (12.1)	3.350 (85.1)	3	7000	B30-R6800-WT
i3300, i5300, BBP33	Fig. 1	B33-5-8117	Matte Black	1.000 (25.4)	0.500 (12.7)	1.075 (27.3)	0.600 (15.2)	3.350 (85.1)	3	5000	B30-R6800-WT
i3300, i5300, BBP33	Fig. 1	B33-147-8117	Matte Black	1.500 (38.1)	0.375 (9.5)	1.650 (41.9)	0.475 (12.1)	3.350 (85.1)	2	5000	B30-R6800-WT
i3300, i5300, BBP33	Fig. 1	B33-1-8117	Matte Black	1.500 (38.1)	0.500 (12.7)	1.650 (41.9)	0.600 (15.2)	3.350 (85.1)	2	3300	B30-R6800-WT
i3300, i5300, BBP33	Fig. 1	B33-6-8117	Matte Black	1.500 (38.1)	0.750 (19.1)	1.650 (41.9)	0.875 (22.2)	3.350 (85.1)	2	2500	B30-R6800-WT
i3300, i5300, BBP33	Fig. 2	B33-53-8117	Matte Black	2.000 (50.8)	0.500 (12.7)	-	0.600 (15.2)	2.200 (55.9)	1	1900	B30-R6800-WT
i3300, i5300, BBP33	Fig. 2	B33-17-8117	Matte Black	2.000 (50.8)	1.000 (25.4)	-	1.125 (28.5)	2.200 (55.9)	1	1000	B30-R6800-WT
i3300, i5300, BBP33	Fig. 2	B33-7-8117	Matte Black	2.750 (69.9)	1.250 (31.8)	-	1.375 (34.9)	2.950 (74.9)	1	750	B30-R6800-WT
i3300, i5300, BBP33	Fig. 2	B33-18-8117	Matte Black	3.000 (76.2)	1.000 (25.4)	-	1.125 (28.5)	3.350 (85.1)	1	1000	B30-R6800-WT
i3300, i5300, BBP33	Fig. 2	B33-19-8117	Matte Black	3.000 (76.2)	2.000 (50.8)	-	2.125 (53.9)	3.200 (81.3)	1	500	B30-R6800-WT
i3300, i5300, BBP33	Fig. 2	B33-55-8117	Matte Black	4.000 (101.6)	2.000 (50.8)	-	2.125 (53.9)	4.200 (106.7)	1	500	B30-R6800-WT
i3300, i5300, BBP33	Fig. 2	B33-76-8117	Matte Black	4.000 (101.6)	3.000 (76.2)	-	3.125 (79.3)	4.200 (106.7)	1	330	B30-R6800-WT
Multi-purpose matte silver polyester with metal appearance but non-metal construction (B-413)											
i3300, i5300, BBP33	Fig. 1	B33-5-413	Matte Silver	1.000 (25.4)	0.500 (12.7)	1.075 (27.3)	0.600 (15.2)	3.350 (85.1)	3	7000	B30-R6000
i3300, i5300, BBP33	Fig. 1	B33-37-413	Matte Silver	1.500 (38.1)	0.500 (12.7)	1.650 (41.9)	0.600 (15.2)	3.350 (85.1)	2	5000	B30-R6000
i3300, i5300, BBP33	Fig. 1	B33-6-413	Matte Silver	1.500 (38.1)	0.750 (19.1)	1.650 (41.9)	0.875 (22.2)	3.350 (85.1)	2	3300	B30-R6000
i3300, i5300, BBP33	Fig. 2	B33-53-413	Matte Silver	2.000 (50.8)	0.500 (12.7)	-	0.600 (15.2)	2.200 (55.9)	1	2500	B30-R6000
i3300, i5300, BBP33	Fig. 2	B33-17-413	Matte Silver	2.000 (50.8)	1.000 (25.4)	-	1.125 (28.5)	2.200 (55.9)	1	1500	B30-R6000
i3300, i5300, BBP33	Fig. 3a	B33C-2000-413	Matte Silver	2.000 (50.8)	100 ft. (30.5 m)	-	-	2.200 (55.9)	1	1 roll (cont.)	B30-R6000
i3300, i5300, BBP33	Fig. 2	B33-7-413	Matte Silver	2.750 (69.9)	1.250 (31.8)	-	1.375 (34.9)	2.950 (74.9)	1	1000	B30-R6000
i3300, i5300, BBP33	Fig. 2	B33-18-413	Matte Silver	3.000 (76.2)	1.000 (25.4)	-	1.125 (28.5)	3.350 (85.1)	1	1500	B30-R6000
i3300, i5300, BBP33	Fig. 3a	B33C-3000-413	Matte Silver	3.000 (76.2)	100 ft. (30.5 m)	-	-	3.200 (81.3)	1	1 roll (cont.)	B30-R6000
i3300, i5300, BBP33	Fig. 2	B33-19-413	Matte Silver	3.000 (76.2)	2.000 (50.8)	-	2.125 (53.9)	3.200 (81.3)	1	700	B30-R6000
i3300, i5300, BBP33	Fig. 3a	B33C-4000-413	Matte Silver	4.000 (101.6)	100 ft. (30.5 m)	-	-	4.200 (106.7)	1	1 roll (cont.)	B30-R6000
i3300, i5300, BBP33	Fig. 2	B33-55-413	Matte Silver	4.000 (101.6)	2.000 (50.8)	-	2.125 (53.9)	4.200 (106.7)	1	750	B30-R6000

High Adhesion Polyester Labels (B-422, B-432, B-484A)

- For general purpose identification, product labels, rating plates and post-process circuit board ID
- For adhesion to flat and smooth or textured surfaces. Consult technical data sheet for UL / CSA ratings and complete performance and testing details

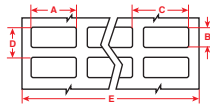

Figure 1

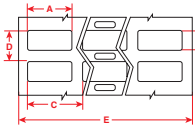

Figure 1d

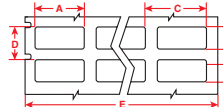

Figure 1e

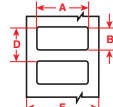

Figure 2

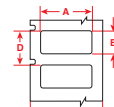

Figure 2c

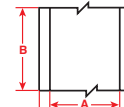

Figure 3a

For Use with Printers:	Diagram	Catalog #	Color	Label width A inch (mm)	Label height B inch (mm)	Horiz. repeat C inch (mm)	Vert. repeat D inch (mm)	Web width E inch (mm)	Labels per row	Labels per roll	Rec. ribbon
High adhesion gloss polyester with stronger adhesive for textured surfaces (B-422)											
i3300, i5300, BBP33	Fig. 1	B33-70-422	Gloss White	0.250 (6.4)	0.250 (6.4)	0.320 (8.1)	0.350 (8.9)	2.370 (60.1)	7	20000	B30-R6000
i3300, i5300, BBP33	Fig. 1	B33-340-422	Gloss White	0.375 (9.5)	0.375 (9.5)	0.438 (11.1)	0.475 (12.1)	3.500 (88.9)	7	10000	B30-R6000
i5300	Fig. 1d	B33-343-422	Gloss White	0.500 (12.7)	0.200 (5.0)	0.625 (15.8)	0.325 (8.2)	3.200 (81.3)	5	10000	B30-R6000
i3300, i5300, BBP33	Fig. 1	B33-12-422	Gloss White	0.500 (12.7)	0.437 (11.0)	0.662 (16.8)	0.537 (13.6)	3.350 (85.1)	5	10000	B30-R6000
i3300, i5300, BBP33	Fig. 1	B33-149-422	Gloss White	0.500 (12.7)	0.500 (12.7)	0.600 (15.2)	0.600 (15.2)	2.500 (63.5)	4	5000	B30-R6000
i5300	Fig. 1d	B33-341-422	Gloss White	0.650 (16.5)	0.200 (5.0)	0.700 (17.7)	0.325 (8.2)	2.950 (74.9)	4	10000	B30-R6000
i3300, i5300, BBP33	Fig. 1	B33-1-422	Gloss White	0.750 (19.1)	0.250 (6.4)	0.800 (20.3)	0.350 (8.9)	3.350 (85.1)	4	10000	B30-R6000
i3300, i5300, BBP33	Fig. 1	B33-2-422	Gloss White	0.900 (22.9)	0.250 (6.4)	1.125 (28.5)	0.350 (8.9)	3.350 (85.1)	3	10000	B30-R6000
i3300, i5300, BBP33	Fig. 1	B33-51-422	Gloss White	1.000 (25.4)	0.250 (6.4)	1.075 (27.3)	0.350 (8.9)	3.350 (85.1)	3	10000	B30-R6000
i3300, i5300, BBP33	Fig. 1	B33-3-422	Gloss White	1.000 (25.4)	0.375 (9.5)	1.075 (27.3)	0.475 (12.1)	3.350 (85.1)	3	7000	B30-R6000
i3300, i5300, BBP33	Fig. 1	B33-5-422	Gloss White	1.000 (25.4)	0.500 (12.7)	1.075 (27.3)	0.600 (15.2)	3.350 (85.1)	3	5000	B30-R6000
i3300, i5300, BBP33	Fig. 1	B33-13-422	Gloss White	1.250 (31.8)	0.250 (6.4)	1.300 (33.0)	0.375 (9.5)	2.750 (69.9)	2	7000	B30-R6000
i3300, i5300, BBP33	Fig. 1	B33-147-422	Gloss White	1.500 (38.1)	0.375 (9.5)	1.650 (41.9)	0.475 (12.1)	3.350 (85.1)	2	2500	B30-R6000
i3300, i5300, BBP33	Fig. 2	B33-102-422	Gloss White	1.500 (38.1)	0.375 (9.5)	-	0.500 (12.7)	1.700 (43.2)	1	2500	B30-R6000
i3300, i5300, BBP33	Fig. 1	B33-37-422	Gloss White	1.500 (38.1)	0.500 (12.7)	1.650 (41.9)	0.600 (15.2)	3.350 (85.1)	2	3500	B30-R6000
i3300, i5300, BBP33	Fig. 1	B33-6-422	Gloss White	1.500 (38.1)	0.750 (19.1)	1.650 (41.9)	0.875 (22.2)	3.350 (85.1)	2	3300	B30-R6000
i3300, i5300, BBP33	Fig. 2	B33-136-422	Gloss White	1.500 (38.1)	0.750 (19.1)	-	0.875 (22.2)	1.700 (43.2)	1	1500	B30-R6000
i3300, i5300, BBP33	Fig. 2	B33-15-422	Gloss White	2.000 (50.8)	0.250 (6.4)	-	0.375 (9.5)	2.200 (55.9)	1	3200	B30-R6000
i3300, i5300, BBP33	Fig. 2	B33-53-422	Gloss White	2.000 (50.8)	0.500 (12.7)	-	0.600 (15.2)	2.200 (55.9)	1	2500	B30-R6000
i3300, i5300, BBP33	Fig. 2	B33-17-422	Gloss White	2.000 (50.8)	1.000 (25.4)	-	1.125 (28.6)	2.200 (55.9)	1	1500	B30-R6000
i3300, i5300, BBP33	Fig. 2	B33-7-422	Gloss White	2.750 (69.9)	1.250 (31.8)	-	1.375 (34.9)	2.950 (74.9)	1	1000	B30-R6000
i3300, i5300, BBP33	Fig. 2	B33-18-422	Gloss White	3.000 (76.2)	1.000 (25.4)	-	1.125 (28.6)	3.200 (81.3)	1	1500	B30-R6000
i3300, i5300, BBP33	Fig. 2	B33-19-422	Gloss White	3.000 (76.2)	2.000 (50.8)	-	2.125 (54.0)	3.200 (81.3)	1	500	B30-R6000
i3300, i5300, BBP33	Fig. 2	B33-55-422	Gloss White	4.000 (101.6)	2.000 (50.8)	-	2.125 (53.9)	4.200 (106.7)	1	500	B30-R6000
i3300, i5300, BBP33	Fig. 2	B33-76-422	Gloss White	4.000 (101.6)	3.000 (76.2)	-	3.125 (79.4)	4.200 (106.7)	1	500	B30-R6000
High adhesion clear polyester with stronger adhesive for textured surfaces (B-432)											
i3300, i5300, BBP33	Fig. 1e	B33-12-432	Clear	0.500 (12.7)	0.437 (11.0)	0.662 (16.8)	0.537 (13.6)	3.350 (85.1)	5	10000	B30-R6000
i3300, i5300, BBP33	Fig. 1e	B33-149-432	Clear	0.500 (12.7)	0.500 (12.7)	0.600 (15.2)	0.625 (15.9)	2.500 (63.5)	4	5000	B30-R6000
i3300, i5300, BBP33	Fig. 1e	B33-5-432	Clear	1.000 (25.4)	0.500 (12.7)	1.075 (27.3)	0.600 (15.2)	3.350 (85.1)	3	1500	B30-R6000
i3300, i5300, BBP33	Fig. 1e	B33-37-432	Clear	1.500 (38.1)	0.500 (12.7)	1.650 (41.9)	0.600 (15.2)	3.350 (85.1)	2	5000	B30-R6000
i3300, i5300, BBP33	Fig. 1e	B33-6-432	Clear	1.500 (38.1)	0.750 (19.1)	1.650 (41.9)	0.875 (22.2)	3.350 (85.1)	2	3300	B30-R6000
i3300, i5300, BBP33	Fig. 2c	B33-53-432	Clear	2.000 (50.8)	0.500 (12.7)	-	0.600 (15.2)	2.200 (55.9)	1	2500	B30-R6000
i3300, i5300, BBP33	Fig. 2c	B33-17-432	Clear	2.000 (50.8)	1.000 (25.4)	-	1.125 (28.6)	2.200 (55.9)	1	1500	B30-R6000
i3300, i5300, BBP33	Fig. 2c	B33-7-432	Clear	2.750 (69.9)	1.250 (31.8)	-	1.375 (34.9)	2.950 (74.9)	1	1000	B30-R6000
i3300, i5300, BBP33	Fig. 2c	B33-18-432	Clear	3.000 (76.2)	1.000 (25.4)	-	1.125 (28.6)	3.200 (81.3)	1	1500	B30-R6000
i3300, i5300, BBP33	Fig. 2c	B33-19-432	Clear	3.000 (76.2)	2.000 (50.8)	-	2.125 (54.0)	3.200 (81.3)	1	500	B30-R6000
i3300, i5300, S3000, S3100, BBP31, BBP33, BBP35, BBP37	Fig. 3a	B30C-4000-432	Clear	4.000 (101.6)	100 ft. (30.5 m)	-	-	4.250 (108.0)	1 roll (cont.)		B30-R6000
High adhesion flexible polyester for conforming to textured and angular or uneven surfaces (B-484A)											
i3300, i5300, BBP33	Fig. 2	B33-125-484	Gloss White	0.900 (22.9)	0.500 (12.7)	-	0.600 (15.2)	1.100 (27.9)	1	1500	B30-R6000
i3300, i5300, BBP33	Fig. 1	B33-5-484	Gloss White	1.000 (25.4)	0.500 (12.7)	1.075 (27.3)	0.600 (15.2)	3.350 (85.1)	3	5000	B30-R6000
i3300, i5300, BBP33	Fig. 2	B33-136-484	Gloss White	1.500 (38.1)	0.750 (19.1)	-	0.875 (22.2)	1.700 (43.2)	1	1500	B30-R6000
i3300, i5300, BBP33	Fig. 2	B33-17-484	Gloss White	2.000 (50.8)	1.000 (25.4)	-	1.125 (28.6)	2.200 (55.9)	1	1500	B30-R6000
i3300, i5300, BBP33	Fig. 2	B33-18-484	Gloss White	3.000 (76.2)	1.000 (25.4)	-	1.125 (28.6)	3.200 (81.3)	1	1500	B30-R6000
i3300, i5300, BBP33	Fig. 2	B33-19-484	Gloss White	3.000 (76.2)	2.000 (50.8)	-	2.125 (54.0)	3.200 (81.3)	1	500	B30-R6000
i3300, i5300, S3000, S3100, BBP35, BBP37	Fig. 3a	B30C-4000-484	Gloss White	4.000 (101.6)	100 ft. (30.5 m)	-	-	4.200 (106.7)	1 roll (cont.)		B30-R6000
i3300, i5300, BBP33	Fig. 2	B33-55-484	Gloss White	4.000 (101.6)	2.000 (50.8)	-	2.125 (53.9)	4.200 (106.7)	1	750	B30-R6000
i3300, i5300, BBP33	Fig. 2	B33-161-484	Gloss White	4.000 (101.6)	4.000 (101.6)	-	4.125 (104.7)	4.200 (106.7)	1	350	B30-R6000

Ultra-High Adhesion Polyester Labels (B-483A, B-489A)

- Ideal for general purpose identification, product labels, rating plates and post-process circuit board ID
- Very high adhesion to flat and smooth or highly textured, rough or powder-coated surfaces. Consult technical data sheet for UL / CSA ratings and complete performance and testing details

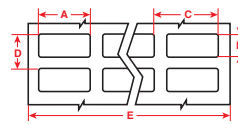

Figure 1

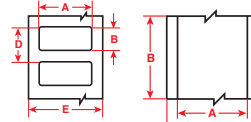

Figure 2

Figure 3a



For Use with Printers:	Diagram	Catalog #	Color	Label width A inch (mm)	Label height B inch (mm)	Horiz. repeat C inch (mm)	Vert. repeat D inch (mm)	Web width E inch (mm)	Labels per row	Labels per roll	Rec. ribbon
Ultra-high adhesion gloss polyester with aggressive adhesive for highly textured surfaces (B-483A)											
i3300, i5300, BBP33	Fig. 1	B33-12-483	Gloss White	0.500 (12.7)	0.437 (11.0)	0.662 (16.8)	0.537 (13.6)	3.350 (85.1)	5	10000	B30-R6000
i3300, i5300, BBP33	Fig. 1	B33-149-483	Gloss White	0.500 (12.7)	0.500 (12.7)	0.600 (15.2)	0.600 (15.2)	2.500 (63.5)	4	5000	B30-R6000
i3300, i5300, BBP33	Fig. 1	B33-5-483	Gloss White	1.000 (25.4)	0.500 (12.7)	1.075 (27.3)	0.600 (15.2)	3.350 (85.1)	3	5000	B30-R6000
i3300, i5300, BBP33	Fig. 1	B33-37-483	Gloss White	1.500 (38.1)	0.500 (12.7)	1.650 (41.9)	0.600 (15.2)	3.350 (85.1)	2	5000	B30-R6000
i3300, i5300, BBP33	Fig. 1	B33-6-483	Gloss White	1.500 (38.1)	0.750 (19.1)	1.650 (41.9)	0.875 (22.2)	3.350 (85.1)	2	3300	B30-R6000
i3300, i5300, BBP33	Fig. 2	B33-53-483	Gloss White	2.000 (50.8)	0.500 (12.7)	-	0.600 (15.2)	2.200 (55.9)	1	2500	B30-R6000
i3300, i5300, BBP33	Fig. 2	B33-17-483	Gloss White	2.000 (50.8)	1.000 (25.4)	-	1.125 (28.6)	2.200 (55.9)	1	1500	B30-R6000
i3300, i5300, BBP33	Fig. 2	B33-7-483	Gloss White	2.750 (69.9)	1.250 (31.8)	-	1.375 (34.9)	2.950 (74.9)	1	1000	B30-R6000
i3300, i5300, BBP33	Fig. 2	B33-18-483	Gloss White	3.000 (76.2)	1.000 (25.4)	-	1.125 (28.6)	3.200 (81.3)	1	1500	B30-R6000
i3300, i5300, BBP33	Fig. 2	B33-19-483	Gloss White	3.000 (76.2)	2.000 (50.8)	-	2.125 (54.0)	3.200 (81.3)	1	500	B30-R6000
i3300, i5300, S3000, S3100, BBP35, BBP37	Fig. 3a	B30C-4000-483	Gloss White	4.000 (101.6)	100 ft. (30.5 m)	-	-	4.200 (106.7)	1 roll (cont.)		B30-R6000
i3300, i5300, BBP33	Fig. 2	B33-55-483	Gloss White	4.000 (101.6)	2.000 (50.8)	-	2.125 (54.0)	4.200 (106.7)	1	750	B30-R6000
i3300, i5300, BBP33	Fig. 2	B33-76-483	Gloss White	4.000 (101.6)	3.000 (76.2)	-	3.125 (79.3)	4.200 (106.7)	1	500	B30-R6000
Ultra-high adhesion matte polyester with aggressive adhesive for highly textured surfaces (B-489A)											
i3300, i5300, BBP33	Fig. 1	B33-12-489	Matte White	0.500 (12.7)	0.437 (11.0)	0.662 (16.8)	0.537 (13.6)	3.350 (85.1)	5	10000	B30-R4300
i3300, i5300, BBP33	Fig. 1	B33-5-489	Matte White	1.000 (25.4)	0.500 (12.7)	1.075 (27.3)	0.600 (15.2)	3.350 (85.1)	3	5000	B30-R4300
i3300, i5300, BBP33	Fig. 1	B33-37-489	Matte White	1.500 (38.1)	0.500 (12.7)	1.650 (41.9)	0.600 (15.2)	3.350 (85.1)	2	5000	B30-R4300
i3300, i5300, BBP33	Fig. 1	B33-6-489	Matte White	1.500 (38.1)	0.750 (19.1)	1.650 (41.9)	0.875 (22.2)	3.350 (85.1)	2	3300	B30-R4300
i3300, i5300, BBP33	Fig. 2	B33-53-489	Matte White	2.000 (50.8)	0.500 (12.7)	-	0.600 (15.2)	2.200 (55.9)	1	2500	B30-R4300
i3300, i5300, BBP33	Fig. 2	B33-17-489	Matte White	2.000 (50.8)	1.000 (25.4)	-	1.125 (28.6)	2.200 (55.9)	1	1500	B30-R4300
i3300, i5300, BBP33	Fig. 2	B33-7-489	Matte White	2.750 (69.9)	1.250 (31.8)	-	1.375 (34.9)	2.950 (74.9)	1	1000	B30-R4300
i3300, i5300, BBP33	Fig. 2	B33-18-489	Matte White	3.000 (76.2)	1.000 (25.4)	-	1.125 (28.6)	3.200 (81.3)	1	1500	B30-R4300
i3300, i5300, BBP33	Fig. 2	B33-19-489	Matte White	3.000 (76.2)	2.000 (50.8)	-	2.125 (54.0)	3.200 (81.3)	1	500	B30-R4300
i3300, i5300, S3000, S3100, BBP35, BBP37	Fig. 3a	B30C-4000-489	Matte White	4.000 (101.6)	100 ft. (30.5 m)	-	-	4.200 (106.7)	1 roll (cont.)		B30-R4300
i3300, i5300, BBP33	Fig. 2	B33-55-489	Matte White	4.000 (101.6)	2.000 (50.8)	-	2.125 (53.9)	4.200 (106.7)	1	750	B30-R4300
i3300, i5300, BBP33	Fig. 2	B33-76-489	Matte White	4.000 (101.6)	3.000 (76.2)	-	3.125 (79.3)	4.200 (106.7)	1	500	B30-R4300

All-Weather Outdoor Polyester (B-8591)

- Outdoor durable low-halogen polyester that resists UV, abrasion and fluids for 12-year average outdoor durability
- Adheres best to flat surfaces and is ideal for outdoor panels, enclosures and equipment
- Consult technical data sheet for UL / CSA ratings, approved print ribbons, and complete weatherability and chemical testing details

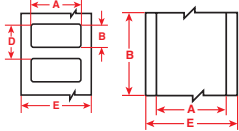
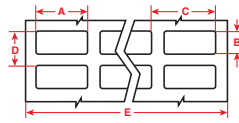

Figure 2

Figure 3a



For Use with Printers:	Diagram	Catalog #	Color	Label width A inch (mm)	Label height B inch (mm)	Horiz. repeat C inch (mm)	Vert. repeat D inch (mm)	Web width E inch (mm)	Labels per row	Labels per roll	Rec. ribbon
i3300, i5300, BBP33	Fig. 1	B33-11-8591-WT	White	0.250 (6.4)	0.250 (6.4)	-	0.375 (9.5)	3.200 (81.3)	12	10000	B30-R6600
i3300, i5300, BBP33	Fig. 1	B33-5-8591-WT	White	1.000 (25.4)	0.500 (12.7)	1.075 (27.3)	0.600 (15.2)	3.350 (85.1)	3	7500	B30-R6600
i3300, i5300, BBP33	Fig. 2	B33-179-8591-WT	White	1.000 (25.4)	1.000 (25.4)	-	1.100 (27.9)	1.200 (30.5)	1	1500	B30-R6600
i3300, i5300, BBP33	Fig. 1	B33-37-8591-WT	White	1.500 (38.1)	0.500 (12.7)	1.650 (41.9)	0.600 (15.2)	3.350 (85.1)	2	4000	B30-R6600
i3300, i5300, BBP33	Fig. 1	B33-6-8591-WT	White	1.500 (38.1)	0.750 (19.1)	1.650 (41.9)	0.875 (22.2)	3.350 (85.1)	2	3500	B30-R6600
i3300, i5300, BBP33	Fig. 2	B33-53-8591-WT	White	2.000 (50.8)	0.500 (12.7)	-	0.600 (15.2)	2.200 (55.9)	1	2500	B30-R6600
i3300, i5300, BBP33	Fig. 2	B33-17-8591-WT	White	2.000 (50.8)	1.000 (25.4)	-	1.125 (29.2)	2.200 (55.9)	1	1500	B30-R6600
i3300, i5300, BBP33	Fig. 3a	B33C-2000-8591-WT	White	2.000 (50.8)	100 ft. (30.5 m)	-	-	2.200 (55.9)	1 roll (cont.)		B30-R6600
i3300, i5300, BBP33	Fig. 2	B33-7-8591-WT	White	2.750 (69.9)	1.250 (31.8)	-	1.375 (34.9)	2.950 (74.9)	1	1000	B30-R6600
i3300, i5300, BBP33	Fig. 2	B33-18-8591-WT	White	3.000 (76.2)	1.000 (25.4)	-	1.125 (29.2)	3.200 (81.3)	1	1500	B30-R6600
i3300, i5300, BBP33	Fig. 2	B33-19-8591-WT	White	3.000 (76.2)	2.000 (50.8)	-	2.125 (54.0)	3.200 (81.3)	1	750	B30-R6600
i3300, i5300, BBP33	Fig. 2	B33-55-8591-WT	White	4.000 (101.6)	2.000 (50.8)	-	2.125 (54.0)	4.200 (106.7)	1	750	B30-R6600
i3300, i5300, BBP33	Fig. 2	B33-76-8591-WT	White	4.000 (101.6)	3.000 (76.2)	-	3.125 (79.3)	4.200 (106.7)	1	400	B30-R6600
i3300, i5300, BBP33	Fig. 2	B33-161-8591-WT	White	4.000 (101.6)	4.000 (101.6)	-	4.125 (104.8)	4.200 (106.7)	1	400	B30-R6600
i3300, i5300, BBP33	Fig. 2	B33-25-8591-WT	White	4.000 (101.6)	6.000 (152.4)	-	6.125 (155.6)	4.200 (106.7)	1	250	B30-R6600
i3300, i5300, BBP33	Fig. 1	B33-11-8591-BK	Black	0.250 (6.4)	0.250 (6.4)	-	0.375 (9.5)	3.200 (81.3)	12	10000	B30-R4400-WT
i3300, i5300, BBP33	Fig. 1	B33-5-8591-BK	Black	1.000 (25.4)	0.500 (12.7)	1.075 (27.3)	0.600 (15.2)	3.350 (85.1)	3	7500	B30-R4400-WT
i3300, i5300, BBP33	Fig. 2	B33-179-8591-BK	Black	1.000 (25.4)	1.000 (25.4)	-	1.100 (27.9)	1.200 (30.5)	1	1500	B30-R4400-WT
i3300, i5300, BBP33	Fig. 1	B33-37-8591-BK	Black	1.500 (38.1)	0.500 (12.7)	1.650 (41.9)	0.600 (15.2)	3.350 (85.1)	2	4000	B30-R4400-WT
i3300, i5300, BBP33	Fig. 1	B33-6-8591-BK	Black	1.500 (38.1)	0.750 (19.1)	1.650 (41.9)	0.875 (22.2)	3.350 (85.1)	2	3500	B30-R4400-WT
i3300, i5300, BBP33	Fig. 2	B33-53-8591-BK	Black	2.000 (50.8)	0.500 (12.7)	-	0.600 (15.2)	2.200 (55.9)	1	2500	B30-R4400-WT
i3300, i5300, BBP33	Fig. 2	B33-17-8591-BK	Black	2.000 (50.8)	1.000 (25.4)	-	1.125 (29.2)	2.200 (55.9)	1	1500	B30-R4400-WT
i3300, i5300, BBP33	Fig. 3a	B33C-2000-8591-BK	Black	2.000 (50.8)	100 ft. (30.5 m)	-	-	2.200 (55.9)	1 roll (cont.)		B30-R4400-WT
i3300, i5300, BBP33	Fig. 2	B33-7-8591-BK	Black	2.750 (69.9)	1.250 (31.8)	-	1.375 (34.9)	2.950 (74.9)	1	1000	B30-R4400-WT
i3300, i5300, BBP33	Fig. 2	B33-18-8591-BK	Black	3.000 (76.2)	1.000 (25.4)	-	1.125 (29.2)	3.200 (81.3)	1	1500	B30-R4400-WT
i3300, i5300, BBP33	Fig. 2	B33-19-8591-BK	Black	3.000 (76.2)	2.000 (50.8)	-	2.125 (54.0)	3.200 (81.3)	1	750	B30-R4400-WT
i3300, i5300, BBP33	Fig. 2	B33-55-8591-BK	Black	4.000 (101.6)	2.000 (50.8)	-	2.125 (54.0)	4.200 (106.7)	1	750	B30-R4400-WT
i3300, i5300, BBP33	Fig. 2	B33-76-8591-BK	Black	4.000 (101.6)	3.000 (76.2)	-	3.125 (79.3)	4.200 (106.7)	1	400	B30-R4400-WT
i3300, i5300, BBP33	Fig. 2	B33-161-8591-BK	Black	4.000 (101.6)	4.000 (101.6)	-	4.125 (104.8)	4.200 (106.7)	1	400	B30-R4400-WT
i3300, i5300, BBP33	Fig. 2	B33-25-8591-BK	Black	4.000 (101.6)	6.000 (152.4)	-	6.125 (155.6)	4.200 (106.7)	1	250	B30-R4400-WT
i3300, i5300, BBP33	Fig. 1	B33-11-8591-SL	Silver	0.250 (6.4)	0.250 (6.4)	-	0.375 (9.5)	3.200 (81.3)	12	10000	B30-R6600
i3300, i5300, BBP33	Fig. 1	B33-5-8591-SL	Silver	1.000 (25.4)	0.500 (12.7)	1.075 (27.3)	0.600 (15.2)	3.350 (85.1)	3	7500	B30-R6600
i3300, i5300, BBP33	Fig. 2	B33-179-8591-SL	Silver	1.000 (25.4)	1.000 (25.4)	-	1.100 (27.9)	1.200 (30.5)	1	1500	B30-R6600
i3300, i5300, BBP33	Fig. 1	B33-37-8591-SL	Silver	1.500 (38.1)	0.500 (12.7)	1.650 (41.9)	0.600 (15.2)	3.350 (85.1)	2	4000	B30-R6600
i3300, i5300, BBP33	Fig. 1	B33-6-8591-SL	Silver	1.500 (38.1)	0.750 (19.1)	1.650 (41.9)	0.875 (22.2)	3.350 (85.1)	2	3500	B30-R6600
i3300, i5300, BBP33	Fig. 2	B33-53-8591-SL	Silver	2.000 (50.8)	0.500 (12.7)	-	0.600 (15.2)	2.200 (55.9)	1	2500	B30-R6600
i3300, i5300, BBP33	Fig. 2	B33-17-8591-SL	Silver	2.000 (50.8)	1.000 (25.4)	-	1.125 (29.2)	2.200 (55.9)	1	1500	B30-R6600
i3300, i5300, BBP33	Fig. 3a	B33C-2000-8591-SL	Silver	2.000 (50.8)	100 ft. (30.5 m)	-	-	2.200 (55.9)	1 roll (cont.)		B30-R6600
i3300, i5300, BBP33	Fig. 2	B33-7-8591-SL	Silver	2.750 (69.9)	1.250 (31.8)	-	1.375 (34.9)	2.950 (74.9)	1	1000	B30-R6600
i3300, i5300, BBP33	Fig. 2	B33-18-8591-SL	Silver	3.000 (76.2)	1.000 (25.4)	-	1.125 (29.2)	3.200 (81.3)	1	1500	B30-R6600
i3300, i5300, BBP33	Fig. 2	B33-19-8591-SL	Silver	3.000 (76.2)	2.000 (50.8)	-	2.125 (54.0)	3.200 (81.3)	1	750	B30-R6600
i3300, i5300, BBP33	Fig. 2	B33-55-8591-SL	Silver	4.000 (101.6)	2.000 (50.8)	-	2.125 (54.0)	4.200 (106.7)	1	750	B30-R6600
i3300, i5300, BBP33	Fig. 2	B33-76-8591-SL	Silver	4.000 (101.6)	3.000 (76.2)	-	3.125 (79.3)	4.200 (106.7)	1	400	B30-R6600
i3300, i5300, BBP33	Fig. 2	B33-161-8591-SL	Silver	4.000 (101.6)	4.000 (101.6)	-	4.125 (104.8)	4.200 (106.7)	1	400	B30-R6600
i3300, i5300, BBP33	Fig. 2	B33-25-8591-SL	Silver	4.000 (101.6)	6.000 (152.4)	-	6.125 (155.6)	4.200 (106.7)	1	250	B30-R6600
i3300, i5300, BBP33	Fig. 1	B33-11-8591-YL	Yellow	0.250 (6.4)	0.250 (6.4)	-	0.375 (9.5)	3.200 (81.3)	12	10000	B30-R6600
i3300, i5300, BBP33	Fig. 1	B33-5-8591-YL	Yellow	1.000 (25.4)	0.500 (12.7)	1.075 (27.3)	0.600 (15.2)	3.350 (85.1)	3	7500	B30-R6600
i3300, i5300, BBP33	Fig. 2	B33-179-8591-YL	Yellow	1.000 (25.4)	1.000 (25.4)	-	1.100 (27.9)	1.200 (30.5)	1	1500	B30-R6600
i3300, i5300, BBP33	Fig. 1	B33-37-8591-YL	Yellow	1.500 (38.1)	0.500 (12.7)	1.650 (41.9)	0.600 (15.2)	3.350 (85.1)	2	4000	B30-R6600
i3300, i5300, BBP33	Fig. 1	B33-6-8591-YL	Yellow	1.500 (38.1)	0.750 (19.1)	1.650 (41.9)	0.875 (22.2)	3.350 (85.1)	2	3500	B30-R6600
i3300, i5300, BBP33	Fig. 2	B33-53-8591-YL	Yellow	2.000 (50.8)	0.500 (12.7)	-	0.600 (15.2)	2.200 (55.9)	1	2500	B30-R6600
i3300, i5300, BBP33	Fig. 2	B33-17-8591-YL	Yellow	2.000 (50.8)	1.000 (25.4)	-	1.125 (29.2)	2.200 (55.9)	1	1500	B30-R6600
i3300, i5300, BBP33	Fig. 1	B33C-2000-8591-YL	Yellow	2.000 (50.8)	100 ft. (30.5 m)	-	-	2.200 (55.9)	1 roll (cont.)		B30-R6600
i3300, i5300, BBP33	Fig. 2	B33-7-8591-YL	Yellow	2.750 (69.9)	1.250 (31.8)	-	1.375 (34.9)	2.950 (74.9)	1	1000	B30-R6600
i3300, i5300, BBP33	Fig. 2	B33-18-8591-YL	Yellow	3.000 (76.2)	1.000 (25.4)	-	1.125 (29.2)	3.200 (81.3)	1	1500	B30-R6600
i3300, i5300, BBP33	Fig. 2	B33-19-8591-YL	Yellow	3.000 (76.2)	2.000 (50.8)	-	2.125 (54.0)	3.200 (81.3)	1	750	B30-R6600
i3300, i5300, BBP33	Fig. 2	B33-55-8591-YL	Yellow	4.000 (101.6)	2.000 (50.8)	-	2.125 (54.0)	4.200 (106.7)	1	750	B30-R6600
i3300, i5300, BBP33	Fig. 2	B33-76-8591-YL	Yellow	4.000 (101.6)	3.000 (76.2)	-	3.125 (79.3)	4.200 (106.7)	1	400	B30-R6600
i3300, i5300, BBP33	Fig. 2	B33-161-8591-YL	Yellow	4.000 (101.6)	4.000 (101.6)	-	4.125 (104.8)	4.200 (106.7)	1	400	B30-R6600
i3300, i5300, BBP33	Fig. 2	B33-25-8591-YL	Yellow	4.000 (101.6)	6.000 (152.4)	-	6.125 (155.6)	4.200 (106.7)	1	250	B30-R6600

High-Adhesion, High-Temp Chemical-Resistant Polyester (B-443)

- For labeling applications where chemical-resistance, self-extinguishing and short-term high-temp properties are required
- Superior resistance to chemicals and fluids that do not have a high pH value
- Excellent long-term temperature resistance and very high short-term resistance to 410°F
- Best for flat and smooth or textured surfaces
- Consult technical data sheet for complete testing and performance details

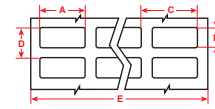

Figure 1

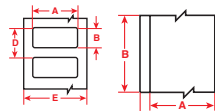

Figure 2



For Use with Printers:	Diagram	Catalog #	Color	Label width A inch (mm)	Label height B inch (mm)	Horiz. repeat C inch (mm)	Vert. repeat D inch (mm)	Web width E inch (mm)	Labels per row	Labels per roll	Rec. ribbon
i3300, i5300, BBP33	Fig. 1	B33-12-443	Matte White	0.500 (12.7)	0.437 (11.0)	0.662 (16.8)	0.537 (13.6)	3.350 (85.1)	5	10000	B30-R6400
i3300, i5300, BBP33	Fig. 1	B33-5-443	Matte White	1.000 (25.4)	0.500 (12.7)	1.075 (27.3)	0.600 (15.2)	3.350 (85.1)	3	7000	B30-R6400
i3300, i5300, BBP33	Fig. 1	B33-147-443	Matte White	1.500 (38.1)	0.375 (9.5)	1.650 (41.9)	0.475 (12.1)	3.350 (85.1)	2	5000	B30-R6400
i3300, i5300, BBP33	Fig. 1	B33-37-443	Matte White	1.500 (38.1)	0.500 (12.7)	1.650 (41.9)	0.600 (15.2)	3.350 (85.1)	2	5000	B30-R6400
i3300, i5300, BBP33	Fig. 1	B33-6-443	Matte White	1.500 (38.1)	0.750 (19.1)	1.650 (41.9)	0.875 (22.2)	3.350 (85.1)	2	3300	B30-R6400
i3300, i5300, BBP33	Fig. 2	B33-53-443	Matte White	2.000 (50.8)	0.500 (12.7)	-	0.600 (15.2)	2.200 (55.9)	1	2500	B30-R6400
i3300, i5300, BBP33	Fig. 2	B33-17-443	Matte White	2.000 (50.8)	1.000 (25.4)	-	1.125 (28.5)	2.200 (55.9)	1	1500	B30-R6400
i3300, i5300, S3000, S3100, BBP30, BBP31, BBP33, BBP35, BBP37	Fig. 3a	B30C-2000-443	Matte White	2.000 (50.8)	100 ft. (30.5 m)	-	-	2.250 (57.2)	1	roll (cont.)	B30-R6400
i3300, i5300, BBP33	Fig. 2	B33-7-443	Matte White	2.750 (69.9)	1.250 (31.8)	-	1.375 (34.9)	2.950 (74.9)	1	1000	B30-R6400
i3300, i5300, BBP33	Fig. 2	B33-18-443	Matte White	3.000 (76.2)	1.000 (25.4)	-	1.125 (28.5)	3.350 (85.1)	1	1500	B30-R6400
i3300, i5300, S3000, S3100, BBP30, BBP31, BBP33, BBP35, BBP37	Fig. 3a	B30C-3000-443	Matte White	3.000 (76.2)	100 ft. (30.5 m)	-	-	3.250 (82.6)	1	roll (cont.)	B30-R6400
i3300, i5300, BBP33	Fig. 2	B33-19-443	Matte White	3.000 (76.2)	2.000 (50.8)	-	2.125 (53.9)	3.200 (81.3)	1	700	B30-R6400
i3300, i5300, S3000, S3100, BBP30, BBP31, BBP33, BBP35, BBP37	Fig. 3a	B30C-4000-443	Matte White	4.000 (101.6)	100 ft. (30.5 m)	-	-	4.250 (107.6)	1	roll (cont.)	B30-R6400
i3300, i5300, BBP33	Fig. 2	B33-55-443	Matte White	4.000 (101.6)	2.000 (50.8)	-	2.125 (53.9)	4.200 (106.7)	1	750	B30-R6400
i3300, i5300, BBP33	Fig. 2	B33-76-443	Matte White	4.000 (101.6)	3.000 (76.2)	-	3.125 (79.3)	4.200 (106.7)	1	500	B30-R6400

Electrostatic Dissipative Polyester (B-473)

- Ideal for labeling electronic components, packaging and post-process circuit boards
- Features both a static dissipative permanent adhesive and a static dissipative release liner and surface resistivity values are in the recommended range for ESD packaging materials (EIA-541 "Packaging Material Standards for ESD Sensitive Items")
- Consult technical data sheet for UL / CSA ratings and complete performance details

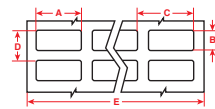

Figure 1

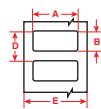

Figure 2

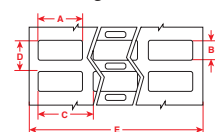

Figure 1d

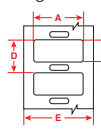

Figure 2d



For Use with Printers:	Diagram	Catalog #	Color	Label width A inch (mm)	Label height B inch (mm)	Horiz. repeat C inch (mm)	Vert. repeat D inch (mm)	Web width E inch (mm)	Labels per row	Labels per roll	Rec. ribbon
i3300, i5300, BBP33	Fig. 1	B33-70-473	Gloss White	0.250 (6.4)	0.250 (6.4)	0.320 (8.1)	0.350 (8.9)	2.370 (60.1)	7	20000	B30-R6000
i3300, i5300, BBP33	Fig. 1	B33-340-473	Gloss White	0.375 (9.5)	0.375 (9.5)	0.438 (11.1)	0.475 (12.1)	3.500 (88.9)	7	10000	B30-R6000
i5300	Fig. 2d	B33-344-473	Gloss White	0.500 (0.0)	0.200 (0.0)	-	0.325 (8.2)	0.850 (21.6)	1	3700	B30-R6000
i5300	Fig. 1d	B33-343-473	Gloss White	0.500 (12.7)	0.200 (5.0)	0.625 (15.8)	0.325 (8.2)	3.200 (81.3)	5	10000	B30-R6000
i3300, i5300, BBP33	Fig. 1	B33-12-473	Gloss White	0.500 (12.7)	0.437 (11.0)	0.662 (16.8)	0.537 (13.6)	3.350 (85.1)	5	10000	B30-R6000
i5300	Fig. 1d	B33-341-473	Gloss White	0.650 (16.5)	0.200 (5.0)	0.700 (17.7)	0.325 (8.2)	2.950 (74.9)	4	10000	B30-R6000
i3300, i5300, BBP33	Fig. 1	B33-1-473	Gloss White	0.750 (19.1)	0.250 (6.4)	0.800 (20.3)	0.350 (8.9)	3.350 (85.1)	4	10000	B30-R6000
i3300, i5300, BBP33	Fig. 1	B33-2-473	Gloss White	0.900 (22.9)	0.250 (6.4)	1.125 (28.5)	0.350 (8.9)	3.350 (85.1)	3	10000	B30-R6000
i3300, i5300, BBP33	Fig. 1	B33-51-473	Gloss White	1.000 (25.4)	0.250 (6.4)	1.075 (27.3)	0.350 (8.9)	3.350 (85.1)	3	10000	B30-R6000
i3300, i5300, BBP33	Fig. 1	B33-3-473	Gloss White	1.000 (25.4)	0.375 (9.5)	1.075 (27.3)	0.475 (12.1)	3.350 (85.1)	3	10000	B30-R6000
i3300, i5300, BBP33	Fig. 1	B33-5-473	Gloss White	1.000 (25.4)	0.500 (12.7)	1.075 (27.3)	0.600 (15.2)	3.350 (85.1)	3	7000	B30-R6000
i3300, i5300, BBP33	Fig. 1	B33-13-473	Gloss White	1.250 (31.8)	0.250 (6.4)	1.300 (33.0)	0.375 (9.5)	2.750 (69.9)	2	5000	B30-R6000
i3300, i5300, BBP33	Fig. 1	B33-4-473	Gloss White	1.500 (38.1)	0.250 (6.4)	1.650 (41.9)	0.350 (8.9)	3.350 (85.1)	2	8000	B30-R6000
i3300, i5300, BBP33	Fig. 2	B33-15-473	Gloss White	2.000 (50.8)	0.250 (6.4)	-	0.375 (9.5)	2.200 (55.9)	1	3200	B30-R6000
i3300, i5300, BBP33	Fig. 2	B33-17-473	Gloss White	2.000 (50.8)	1.000 (25.4)	-	1.125 (28.5)	2.200 (55.9)	1	1500	B30-R6000

Metallized Polyester Labels with Standard Adhesion (B-428, B-435A, B-413, B-8591)

- For labeling applications where a metal label or metal appearance is required
- Ideal for rating plates and product labels
- Adheres best to flat, smooth surfaces
- Consult technical data sheet for UL / CSA ratings and complete performance and testing details

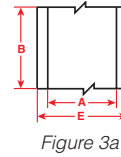
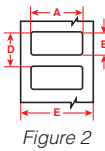
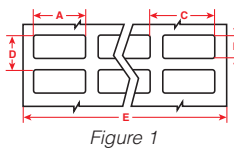

For Use with Printers:	Diagram	Catalog #	Color	Label width A inch (mm)	Label height B inch (mm)	Horiz. repeat C inch (mm)	Vert. repeat D inch (mm)	Web width E inch (mm)	Labels per row	Labels per roll	Rec. ribbon
Matte light gray metallized polyester (B-428)											
i3300, i5300, BBP33	Fig. 1	B33-5-428	Matte Lt. Gray	1.000 (25.4)	0.500 (12.7)	1.075 (27.3)	0.600 (15.2)	3.350 (85.1)	3	5000	B30-R4300
i3300, i5300, BBP33	Fig. 1	B33-37-428	Matte Lt. Gray	1.500 (38.1)	0.500 (12.7)	1.650 (41.9)	0.600 (15.2)	3.350 (85.1)	2	4000	B30-R4300
i3300, i5300, BBP33	Fig. 1	B33-6-428	Matte Lt. Gray	1.500 (38.1)	0.750 (19.1)	1.650 (41.9)	0.875 (22.2)	3.350 (85.1)	2	3000	B30-R4300
i3300, i5300, BBP33	Fig. 2	B33-53-428	Matte Lt. Gray	2.000 (50.8)	0.500 (12.7)	-	0.600 (15.2)	2.200 (55.9)	1	2500	B30-R4300
i3300, i5300, BBP33	Fig. 2	B33-17-428	Matte Lt. Gray	2.000 (50.8)	1.000 (25.4)	-	1.125 (28.6)	2.200 (55.9)	1	1500	B30-R4300
i3300, i5300, S3000, S3100, BBP30, BBP31, BBP33, BBP35, BBP37	Fig. 3a	B30C-2000-428	Matte Lt. Gray	2.000 (50.8)	100 ft. (30.5 m)	-	-	2.250 (57.2)	1 roll (cont.)		B30-R4300
i3300, i5300, BBP33	Fig. 2	B33-7-428	Matte Lt. Gray	2.750 (69.9)	1.250 (31.8)	-	1.375 (34.9)	2.950 (74.9)	1	1000	B30-R4300
i3300, i5300, BBP33	Fig. 2	B33-18-428	Matte Lt. Gray	3.000 (76.2)	1.000 (25.4)	-	1.125 (28.6)	3.200 (81.3)	1	1500	B30-R4300
i3300, i5300, BBP33	Fig. 2	B33-19-428	Matte Lt. Gray	3.000 (76.2)	2.000 (50.8)	-	2.125 (54.0)	3.200 (81.3)	1	500	B30-R4300
i3300, i5300, S3000, S3100, BBP30, BBP31, BBP33, BBP35, BBP37	Fig. 3a	B33C-3000-428	Matte Lt. Gray	3.000 (76.2)	85 ft. (25.9m)	-	-	3.400 (86.4)	1 roll (cont.)		B30-R4300
i3300, i5300, S3000, S3100, BBP30, BBP31, BBP33, BBP35, BBP37	Fig. 3a	B30C-4000-428	Matte Lt. Gray	4.000 (101.6)	130 ft. (39.6m)	-	-	4.200 (106.7)	1 roll (cont.)		B30-R4300
i3300, i5300, BBP33	Fig. 2	B33-55-428	Matte Lt. Gray	4.000 (101.6)	2.000 (50.8)	-	2.125 (53.9)	4.200 (106.7)	1	500	B30-R4300
i3300, i5300, BBP33	Fig. 2	B33-161-428	Matte Lt. Gray	4.000 (101.6)	4.000 (101.6)	-	4.125 (104.7)	4.200 (106.7)	1	300	B30-R4300
High gloss silver metallized polyester (B-435A)											
i3300, i5300, BBP33	Fig. 1	B33-5-435	Gloss Silver	1.000 (25.4)	0.500 (12.7)	1.075 (27.3)	0.600 (15.2)	3.350 (85.1)	3	7000	B30-R6000
i3300, i5300, BBP33	Fig. 1	B33-37-435	Gloss Silver	1.500 (38.1)	0.500 (12.7)	1.650 (41.9)	0.600 (15.2)	3.350 (85.1)	2	5000	B30-R6000
i3300, i5300, BBP33	Fig. 1	B33-6-435	Gloss Silver	1.500 (38.1)	0.750 (19.1)	1.650 (41.9)	0.875 (22.2)	3.350 (85.1)	2	3300	B30-R6000
i3300, i5300, BBP33	Fig. 2	B33-53-435	Gloss Silver	2.000 (50.8)	0.500 (12.7)	-	0.600 (15.2)	2.200 (55.9)	1	2500	B30-R6000
i3300, i5300, BBP33	Fig. 2	B33-17-435	Gloss Silver	2.000 (50.8)	1.000 (25.4)	-	1.125 (28.5)	2.200 (55.9)	1	1500	B30-R6000
i3300, i5300, BBP33	Fig. 3	B33C-2000-435	Gloss Silver	2.000 (50.8)	100 ft. (30.5 m)	-	-	2.200 (55.9)	1 roll (cont.)		B30-R6000
i3300, i5300, BBP33	Fig. 2	B33-7-435	Gloss Silver	2.750 (69.9)	1.250 (31.8)	-	1.375 (34.9)	2.950 (74.9)	1	1000	B30-R6000
i3300, i5300, BBP33	Fig. 2	B33-18-435	Gloss Silver	3.000 (76.2)	1.000 (25.4)	-	1.125 (28.6)	3.200 (81.3)	1	1500	B30-R6000
i3300, i5300, BBP33	Fig. 3a	B33C-3000-435	Gloss Silver	3.000 (76.2)	100 ft. (30.5 m)	-	-	3.200 (81.3)	1 roll (cont.)		B30-R6000
i3300, i5300, BBP33	Fig. 2	B33-19-435	Gloss Silver	3.000 (76.2)	2.000 (50.8)	-	2.125 (54.0)	3.200 (81.3)	1	500	B30-R6000
i3300, i5300, BBP33	Fig. 2	B33-55-435	Gloss Silver	4.000 (101.6)	2.000 (50.8)	-	2.125 (54.0)	4.200 (106.7)	1	750	B30-R6000
i3300, i5300, BBP33	Fig. 2	B33-161-435	Gloss Silver	4.000 (101.6)	4.000 (101.6)	-	4.125 (104.7)	4.200 (106.7)	1	350	B30-R6000
Matte silver metallic-looking polyester but non-metal construction (B-413)											
i3300, i5300, BBP33	Fig. 1	B33-5-413	Matte Silver	1.000 (25.4)	0.500 (12.7)	1.075 (27.3)	0.600 (15.2)	3.350 (85.1)	3	7000	B30-R6000
i3300, i5300, BBP33	Fig. 1	B33-37-413	Matte Silver	1.500 (38.1)	0.500 (12.7)	1.650 (41.9)	0.600 (15.2)	3.350 (85.1)	2	5000	B30-R6000
i3300, i5300, BBP33	Fig. 1	B33-6-413	Matte Silver	1.500 (38.1)	0.750 (19.1)	1.650 (41.9)	0.875 (22.2)	3.350 (85.1)	2	3300	B30-R6000
i3300, i5300, BBP33	Fig. 2	B33-53-413	Matte Silver	2.000 (50.8)	0.500 (12.7)	-	0.600 (15.2)	2.200 (55.9)	1	2500	B30-R6000
i3300, i5300, BBP33	Fig. 2	B33-17-413	Matte Silver	2.000 (50.8)	1.000 (25.4)	-	1.125 (28.5)	2.200 (55.9)	1	1500	B30-R6000
i3300, i5300, BBP33	Fig. 3a	B33C-2000-413	Matte Silver	2.000 (50.8)	100 ft. (30.5 m)	-	-	2.200 (55.9)	1	1 roll (cont.)	B30-R6000
i3300, i5300, BBP33	Fig. 2	B33-7-413	Matte Silver	2.750 (69.9)	1.250 (31.8)	-	1.375 (34.9)	2.950 (74.9)	1	1000	B30-R6000
i3300, i5300, BBP33	Fig. 2	B33-18-413	Matte Silver	3.000 (76.2)	1.000 (25.4)	-	1.125 (28.5)	3.350 (85.1)	1	1500	B30-R6000
i3300, i5300, BBP33	Fig. 3a	B33C-3000-413	Matte Silver	3.000 (76.2)	100 ft. (30.5 m)	-	-	3.200 (81.3)	1	1 roll (cont.)	B30-R6000
i3300, i5300, BBP33	Fig. 2	B33-19-413	Matte Silver	3.000 (76.2)	2.000 (50.8)	-	2.125 (53.9)	3.200 (81.3)	1	700	B30-R6000
i3300, i5300, BBP33	Fig. 3a	B33C-4000-413	Matte Silver	4.000 (101.6)	100 ft. (30.5 m)	-	-	4.200 (106.7)	1	1 roll (cont.)	B30-R6000
i3300, i5300, BBP33	Fig. 2	B33-55-413	Matte Silver	4.000 (101.6)	2.000 (50.8)	-	2.125 (53.9)	4.200 (106.7)	1	750	B30-R6000
Outdoor grade matte silver metallic-looking polyester but non-metal construction (B-8591)											
i3300, i5300, BBP33	Fig. 1	B33-11-8591-SL	Silver	0.250 (6.4)	0.250 (6.4)	-	0.375 (9.5)	3.200 (81.3)	12	10000	B30-R6600
i3300, i5300, BBP33	Fig. 1	B33-5-8591-SL	Silver	1.000 (25.4)	0.500 (12.7)	1.075 (27.3)	0.600 (15.2)	3.350 (85.1)	3	7500	B30-R6600
i3300, i5300, BBP33	Fig. 2	B33-179-8591-SL	Silver	1.000 (25.4)	1.000 (25.4)	-	1.100 (27.9)	TBD	1	1500	B30-R6600
i3300, i5300, BBP33	Fig. 1	B33-37-8591-SL	Silver	1.500 (38.1)	0.500 (12.7)	1.650 (41.9)	0.600 (15.2)	3.350 (85.1)	2	4000	B30-R6600
i3300, i5300, BBP33	Fig. 1	B33-6-8591-SL	Silver	1.500 (38.1)	0.750 (19.1)	1.650 (41.9)	0.875 (22.2)	3.350 (85.1)	2	3500	B30-R6600
i3300, i5300, BBP33	Fig. 2	B33-53-8591-SL	Silver	2.000 (50.8)	0.500 (12.7)	-	0.600 (15.2)	2.200 (55.9)	1	2500	B30-R6600
i3300, i5300, BBP33	Fig. 2	B33-17-8591-SL	Silver	2.000 (50.8)	1.000 (25.4)	-	1.125 (29.2)	2.200 (55.9)	1	1500	B30-R6600
i3300, i5300, BBP33	Fig. 3a	B33C-2000-8591-SL	Silver	2.000 (50.8)	100 ft. (30.5 m)	-	-	2.200 (55.9)	1 roll (cont.)		B30-R6600
i3300, i5300, BBP33	Fig. 2	B33-7-8591-SL	Silver	2.750 (69.9)	1.250 (31.8)	-	1.375 (34.9)	2.950 (74.9)	1	1000	B30-R6600
i3300, i5300, BBP33	Fig. 2	B33-18-8591-SL	Silver	3.000 (76.2)	1.000 (25.4)	-	1.125 (29.2)	3.200 (81.3)	1	1500	B30-R6600
i3300, i5300, BBP33	Fig. 2	B33-19-8591-SL	Silver	3.000 (76.2)	2.000 (50.8)	-	2.125 (54.0)	3.200 (81.3)	1	750	B30-R6600
i3300, i5300, BBP33	Fig. 2	B33-55-8591-SL	Silver	4.000 (101.6)	2.000 (50.8)	-	2.125 (54.0)	4.200 (106.7)	1	750	B30-R6600
i3300, i5300, BBP33	Fig. 2	B33-76-8591-SL	Silver	4.000 (101.6)	3.000 (76.2)	-	3.125 (79.3)	4.200 (106.7)	1	400	B30-R6600
i3300, i5300, BBP33	Fig. 2	B33-161-8591-SL	Silver	4.000 (101.6)	4.000 (101.6)	-	4.125 (104.8)	4.200 (106.7)	1	400	B30-R6600
i3300, i5300, BBP33	Fig. 2	B33-25-8591-SL	Silver	4.000 (101.6)	6.000 (152.4)	-	6.125 (155.6)	4.200 (106.7)	1	250	B30-R6600

High Adhesion Metallized Polyester Labels (B-434A)

- Ideal for rating plates and product labels
- Adheres best to flat and smooth or textured surfaces or when extra adhesion is required
- Consult technical data sheet for UL / CSA ratings and complete performance and testing details

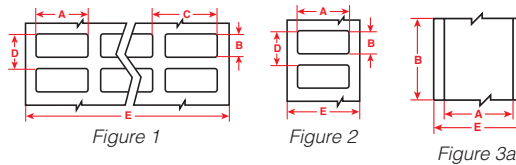

For Use with Printers:	Diagram	Catalog #	Color	Label width A inch (mm)	Label height B inch (mm)	Horiz. repeat C inch (mm)	Vert. repeat D inch (mm)	Web width E inch (mm)	Labels per row	Labels per roll	Rec. ribbon
High gloss silver metallized polyester with high adhesion for textured surfaces (B-434A)											
i3300, i5300, BBP33	Fig. 1	B33-5-434	Gloss Silver	1.000 (25.4)	0.500 (12.7)	1.075 (27.3)	0.600 (15.2)	3.350 (85.1)	3	5000	B30-R6000
i3300, i5300, BBP33	Fig. 1	B33-37-434	Gloss Silver	1.500 (38.1)	0.500 (12.7)	1.650 (41.9)	0.600 (15.2)	3.350 (85.1)	2	5000	B30-R6000
i3300, i5300, BBP33	Fig. 1	B33-6-434	Gloss Silver	1.500 (38.1)	0.750 (19.1)	1.650 (41.9)	0.875 (22.2)	3.350 (85.1)	2	3300	B30-R6000
i3300, i5300, BBP33	Fig. 2	B33-136-434	Gloss Silver	1.500 (38.1)	0.750 (19.1)	-	0.875 (22.2)	1.700 (43.2)	1	1500	B30-R6000
i3300, i5300, BBP33	Fig. 2	B33-53-434	Gloss Silver	2.000 (50.8)	0.500 (12.7)	-	0.600 (15.2)	2.200 (55.9)	1	2500	B30-R6000
i3300, i5300, BBP33	Fig. 2	B33-17-434	Gloss Silver	2.000 (50.8)	1.000 (25.4)	-	1.125 (28.6)	2.200 (55.9)	1	1500	B30-R6000
i3300, i5300, S3000, S3100, BBP30, BBP31, BBP33, BBP35, BBP37	Fig. 3a	B30C-2000-434	Gloss Silver	2.000 (50.8)	100 ft. (30.5 m)	-	-	2.250 (57.2)	1 roll (cont.)		B30-R6000
i3300, i5300, BBP33	Fig. 2	B33-7-434	Gloss Silver	2.750 (69.9)	1.250 (31.8)	-	1.375 (34.9)	2.950 (74.9)	1	1000	B30-R6000
i3300, i5300, BBP33	Fig. 2	B33-18-434	Gloss Silver	3.000 (76.2)	1.000 (25.4)	-	1.125 (28.6)	3.200 (81.3)	1	1500	B30-R6000
i3300, i5300, S3000, S3100, BBP30, BBP31, BBP33, BBP35, BBP37	Fig. 3a	B30C-3000-434	Gloss Silver	3.000 (76.2)	100 ft. (30.5 m)	-	-	3.250 (82.6)	1 roll (cont.)		B30-R6000
i3300, i5300, BBP33	Fig. 2	B33-19-434	Gloss Silver	3.000 (76.2)	2.000 (50.8)	-	2.125 (54.0)	3.200 (81.3)	1	500	B30-R6000
i3300, i5300, S3000, S3100, BBP30, BBP31, BBP33, BBP35, BBP37	Fig. 3a	B30C-4000-434	Gloss Silver	4.000 (101.6)	100 ft. (30.5 m)	-	-	4.200 (106.7)	1 roll (cont.)		B30-R6000
i3300, i5300, BBP33	Fig. 2	B33-55-434	Gloss Silver	4.000 (101.6)	2.000 (50.8)	-	2.125 (54.0)	4.200 (106.7)	1	750	B30-R6000
i3300, i5300, BBP33	Fig. 2	B33-161-434	Gloss Silver	4.000 (101.6)	4.000 (101.6)	-	4.125 (104.7)	4.200 (106.7)	1	350	B30-R6000

Ultra-High Adhesion Metallized Polyester Labels (B-486B)

- Ideal for electrical panel rating plates, product labels and asset ID tracking labels
- Very high adhesion to flat and smooth or highly textured, rough or powder-coated surfaces. Consult technical data sheet for UL / CSA ratings and complete performance and testing details

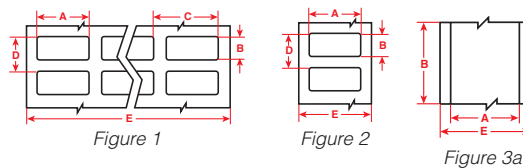

For Use with Printers:	Diagram	Catalog #	Color	Label width A inch (mm)	Label height B inch (mm)	Horiz. repeat C inch (mm)	Vert. repeat D inch (mm)	Web width E inch (mm)	Labels per row	Labels per roll	Rec. ribbon
Ultra high adhesion matte light gray metallized polyester with aggressive adhesive for highly textured surfaces (B-486B)											
i3300, i5300, BBP33	Fig. 2	B33-59-486	Matte Lt. Gray	1.000 (25.4)	0.500 (12.7)	-	0.600 (15.2)	1.200 (30.5)	1	2500	B30-R4300
i3300, i5300, BBP33	Fig. 1	B33-5-486	Matte Lt. Gray	1.000 (25.4)	0.500 (12.7)	1.075 (27.3)	0.600 (15.2)	3.350 (85.1)	3	5000	B30-R4300
i3300, i5300, BBP33	Fig. 1	B33-37-486	Matte Lt. Gray	1.500 (38.1)	0.500 (12.7)	1.650 (41.9)	0.600 (15.2)	3.350 (85.1)	2	4000	B30-R4300
i3300, i5300, BBP33	Fig. 1	B33-6-486	Matte Lt. Gray	1.500 (38.1)	0.750 (19.1)	1.650 (41.9)	0.875 (22.2)	3.350 (85.1)	2	3000	B30-R4300
i3300, i5300, BBP33	Fig. 2	B33-53-486	Matte Lt. Gray	2.000 (50.8)	0.500 (12.7)	-	0.600 (15.2)	2.200 (55.9)	1	2500	B30-R4300
i3300, i5300, BBP33	Fig. 2	B33-17-486	Matte Lt. Gray	2.000 (50.8)	1.000 (25.4)	-	1.125 (28.6)	2.200 (55.9)	1	1300	B30-R4300
i3300, i5300, BBP33	Fig. 2	B33-7-486	Matte Lt. Gray	2.750 (69.9)	1.250 (31.8)	-	1.375 (34.9)	2.950 (74.9)	1	1000	B30-R4300
i3300, i5300, BBP33	Fig. 2	B33-18-486	Matte Lt. Gray	3.000 (76.2)	1.000 (25.4)	-	1.125 (28.6)	3.200 (81.3)	1	1300	B30-R4300
i3300, i5300, BBP33	Fig. 2	B33-19-486	Matte Lt. Gray	3.000 (76.2)	2.000 (50.8)	-	2.125 (54.0)	3.200 (81.3)	1	500	B30-R4300
i3300, i5300, S3000, S3100, BBP35, BBP37	Fig. 3a	B30C-4000-486	Matte Lt. Gray	4.000 (101.6)	100 ft. (30.5 m)	-	-	4.200 (106.7)	1 roll (cont.)		B30-R4300
i3300, i5300, BBP33	Fig. 2	B33-55-486	Matte Lt. Gray	4.000 (101.6)	2.000 (50.8)	-	2.125 (53.9)	4.200 (106.7)	1	500	B30-R4300
i3300, i5300, BBP33	Fig. 2	B33-76-486	Matte Lt. Gray	4.000 (101.6)	3.000 (76.2)	-	3.125 (79.4)	4.200 (106.7)	1	500	B30-R4300
i3300, i5300, BBP33	Fig. 2	B33-161-486	Matte Lt. Gray	4.000 (101.6)	4.000 (101.6)	-	4.125 (104.8)	4.200 (106.7)	1	250	B30-R4300

Tamper-Evident Checkerboard Pattern Metallized Polyester Labels (B-438)

- Leaves an aggressive adhesive checkerboard pattern on the surface if label is removed with a matching pattern on the removed label to prevent it from being reused
- Ideal for asset tracking labels and warranty labels on products
- Consult technical data sheet for UL / CSA ratings and complete performance and testing details

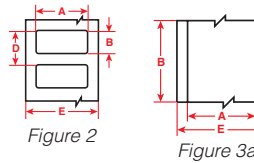
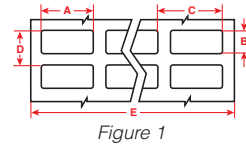

For Use with Printers:	Diagram	Catalog #	Color	Label width A inch (mm)	Label height B inch (mm)	Horiz. repeat C inch (mm)	Vert. repeat D inch (mm)	Web width E inch (mm)	Labels per row	Labels per roll	Rec. ribbon
i3300, i5300, BBP33	Fig. 1	B33-5-438	Matte Silver	1.000 (25.4)	0.500 (12.7)	1.075 (27.3)	0.600 (15.2)	3.350 (85.1)	3	7000	B30-R4300
i3300, i5300, BBP33	Fig. 1	B33-37-438	Matte Silver	1.500 (38.1)	0.500 (12.7)	1.650 (41.9)	0.600 (15.2)	3.350 (85.1)	2	5000	B30-R4300
i3300, i5300, BBP33	Fig. 1	B33-6-438	Matte Silver	1.500 (38.1)	0.750 (19.1)	1.650 (41.9)	0.875 (22.2)	3.350 (85.1)	2	3300	B30-R4300
i3300, i5300, BBP33	Fig. 2	B33-53-438	Matte Silver	2.000 (50.8)	0.500 (12.7)	-	0.600 (15.2)	2.200 (55.9)	1	2500	B30-R4300
i3300, i5300, BBP33	Fig. 2	B30-17-438	Matte Silver	2.000 (50.8)	1.000 (25.4)	-	1.125 (28.6)	2.500 (63.5)	1	1225	B30-R4300
i3300, i5300, BBP33	Fig. 2	B33-7-438	Matte Silver	2.750 (69.9)	1.250 (31.8)	-	1.375 (34.9)	2.950 (74.9)	1	1000	B30-R4300
i3300, i5300, BBP33	Fig. 2	B30-18-438	Matte Silver	3.000 (76.2)	1.000 (25.4)	-	1.250 (31.8)	3.250 (82.6)	1	1225	B30-R4300
i3300, i5300, S3000, S3100, BBP30, BBP31, BBP33, BBP35, BBP37	Fig. 3a	B30C-3000-438-SL	Matte Silver	3.000 (76.2)	100 ft. (30.5 m)	-	-	3.250 (82.6)	1 roll (cont.)		B30-R4300
i3300, i5300, BBP33	Fig. 2	B30-222-438	Matte Silver	3.000 (76.2)	2.000 (50.8)	-	2.250 (57.2)	3.250 (82.6)	1	650	B30-R4300
i3300, i5300, BBP33	Fig. 2	B33-55-438	Matte Silver	4.000 (101.6)	2.000 (50.8)	-	2.125 (53.9)	4.200 (106.7)	1	750	B30-R4300
i3300, i5300, BBP33	Fig. 2	B33-76-438	Matte Silver	4.000 (101.6)	3.000 (76.2)	-	3.125 (79.3)	4.200 (106.7)	1	500	B30-R4300

Chemical and Solvent Resistant Matte Polypropylene Labels (B-425A)

- Excellent solvent, fuel oil and liquids resistance
- Also has write-on ability for printed labels that require future hand-written data be added
- Flexible material conforms to irregular surfaces better than traditional polyesters
- Consult technical data sheet for UL / CSA ratings and complete performance and testing details

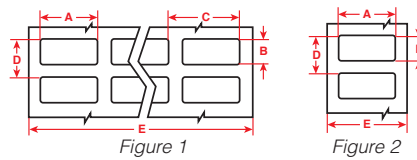

For Use with Printers:	Diagram	Catalog #	Color	Label width A inch (mm)	Label height B inch (mm)	Horiz. repeat C inch (mm)	Vert. repeat D inch (mm)	Web width E inch (mm)	Labels per row	Labels per roll	Rec. ribbon
i3300, i5300, BBP33	Fig. 1	B33-5-425	White	1.000 (25.4)	0.500 (12.7)	1.075 (27.3)	0.600 (15.2)	3.350 (85.1)	3	5000	B30-R4300
i3300, i5300, BBP33	Fig. 1	B33-6-425	White	1.500 (38.1)	0.750 (19.1)	1.650 (41.9)	0.875 (22.2)	3.350 (85.1)	2	3300	B30-R4300
i3300, i5300, BBP33	Fig. 2	B33-53-425	White	2.000 (50.8)	0.500 (12.7)	-	0.600 (15.2)	2.200 (55.9)	1	2000	B30-R4300
i3300, i5300, BBP33	Fig. 2	B33-17-425	White	2.000 (50.8)	1.000 (25.4)	-	1.125 (28.6)	2.200 (55.9)	1	1500	B30-R4300
i3300, i5300, BBP33	Fig. 2	B33-7-425	White	2.750 (69.9)	1.250 (31.8)	-	1.375 (34.9)	2.950 (74.9)	1	1000	B30-R4300
i3300, i5300, BBP33	Fig. 2	B33-18-425	White	3.000 (76.2)	1.000 (25.4)	-	1.125 (28.6)	3.200 (81.3)	1	1500	B30-R4300
i3300, i5300, BBP33	Fig. 2	B33-19-425	White	3.000 (76.2)	2.000 (50.8)	-	2.125 (54.0)	3.200 (81.3)	1	500	B30-R4300
i3300, i5300, BBP33	Fig. 2	B33-20-425	White	3.000 (76.2)	5.000 (127.0)	-	5.125 (130.1)	3.200 (81.3)	1	250	B30-R4300
i3300, i5300, BBP33	Fig. 2	B33-55-425	White	4.000 (101.6)	2.000 (50.8)	-	2.125 (53.9)	4.200 (106.7)	1	600	B30-R4300
i3300, i5300, BBP33	Fig. 2	B33-76-425	White	4.000 (101.6)	3.000 (76.2)	-	3.125 (79.3)	4.200 (106.7)	1	400	B30-R4300

PermaShield™ Overlaminating Labels with Standard Adhesion (B-423/B-966B, B-428/B-966B)

- Supplied as a standard label with matching clear polyester overlaminating mounted beneath the label
- The label is printed, removed from liner and applied to surface, and then the overlaminating is removed and applied over the label protecting printed text
- Overlaminating sized to extend slightly beyond the dimension of the printed label
- Excellent abrasion and environmental resistance
- Consult technical data sheet for UL / CSA ratings and complete performance and testing details

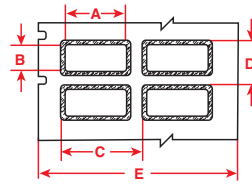

Figure 10b

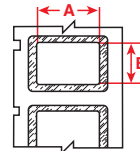

Figure 40



For Use with Printers:	Diagram	Catalog #	Color	Label width A inch (mm)	Label height B inch (mm)	Horiz. repeat C inch (mm)	Vert. repeat D inch (mm)	Web width E inch (mm)	Labels per row	Labels per roll	Rec. ribbon
PermaShield™ Overlaminating Polyester (B-423/B-966B)											
i3300, i5300, BBP33	Fig. 10b	B33-22-423	Gloss White	1.250 (31.8)	0.750 (19.1)	1.650 (41.9)	1.125 (28.5)	3.350 (85.1)	2	2000	B30-R6000
i3300, i5300, BBP33	Fig. 10b	B33-23-423	Gloss White	2.000 (50.8)	1.000 (25.4)	-	1.375 (34.9)	2.450 (62.2)	1	800	B30-R6000
i3300, i5300, BBP33	Fig. 10b	B33-24-423	Gloss White	2.750 (69.9)	1.750 (44.4)	-	2.125 (53.9)	3.200 (81.3)	1	500	B30-R6000
PermaShield™ Overlaminating Metallized Polyester (B-428/B-966B)											
i3300, i5300, BBP33	Fig. 40	B33-22-428	Matte Lt. Gray	1.250 (31.8)	0.750 (19.1)	1.650 (41.9)	1.125 (28.5)	3.350 (85.1)	2	1700	B30-R4300
i3300, i5300, BBP33	Fig. 40	B33-23-428	Matte Lt. Gray	2.000 (50.8)	1.000 (25.4)	-	1.375 (34.9)	2.450 (62.2)	1	700	B30-R4300
i3300, i5300, BBP33	Fig. 40	B33-24-428	Matte Lt. Gray	2.750 (69.9)	1.750 (44.4)	-	2.125 (53.9)	3.200 (81.3)	1	450	B30-R4300

High Adhesion General Purpose Vinyl Die-Cut Labels (B-439)

- Indoor and outdoor grade vinyl with high-tack permanent adhesive
- Extremely pliable and highly conforming to rough and irregular surfaces with good chemical and abrasion resistance
- Ideal for general purpose warehouse and industrial labeling when label size consistency and a die-cut put-up is desired
- Not UL / CSA rated
- Consult technical data sheet for complete performance and testing details

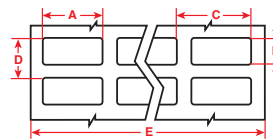

Figure 1

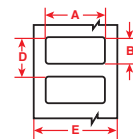

Figure 2



For Use with Printers:	Diagram	Catalog #	Color	Label width A inch (mm)	Label height B inch (mm)	Horiz. repeat C inch (mm)	Vert. repeat D inch (mm)	Web width E inch (mm)	Labels per row	Labels per roll	Rec. ribbon
i3300, i5300, BBP33	Fig. 1	B33-5-439	White	1.000 (25.4)	0.500 (12.7)	1.075 (27.3)	0.600 (15.2)	3.350 (85.1)	3	7000	B30-R6000
i3300, i5300, BBP33	Fig. 1	B33-37-439	White	1.500 (38.1)	0.500 (12.7)	1.650 (41.9)	0.600 (15.2)	3.350 (85.1)	2	5000	B30-R6000
i3300, i5300, BBP33	Fig. 2	B33-53-439	White	2.000 (50.8)	0.500 (12.7)	-	0.600 (15.2)	2.200 (55.9)	1	2500	B30-R6000
i3300, i5300, BBP33	Fig. 2	B33-17-439	White	2.000 (50.8)	1.000 (25.4)	-	1.125 (28.5)	2.200 (55.9)	1	1000	B30-R6000
i3300, i5300, BBP33	Fig. 2	B33-18-439	White	3.000 (76.2)	1.000 (25.4)	-	1.125 (28.5)	3.350 (85.1)	1	1000	B30-R6000
i3300, i5300, BBP33	Fig. 2	B33-19-439	White	3.000 (76.2)	2.000 (50.8)	-	2.125 (53.9)	3.200 (81.3)	1	700	B30-R6000
i3300, i5300, BBP33	Fig. 2	B33-55-439	White	4.000 (101.6)	2.000 (50.8)	-	2.125 (53.9)	4.200 (106.7)	1	700	B30-R6000
i3300, i5300, BBP33	Fig. 2	B33-76-439	White	4.000 (101.6)	3.000 (76.2)	-	3.125 (79.3)	4.200 (106.7)	1	500	B30-R6000

Paper Labels

(B-424)

- Economical choice for light duty part labeling, box labels and general identification on very bright white labels
- Bright white finish with excellent image contrast and smear resistance for barcode printing

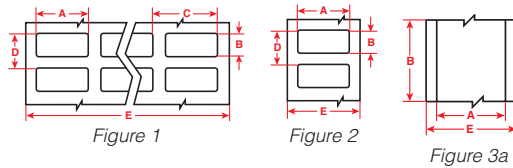

For Use with Printers:	Diagram	Catalog #	Color	Label width A inch (mm)	Label height B inch (mm)	Horiz. repeat C inch (mm)	Vert. repeat D inch (mm)	Web width E inch (mm)	Labels per row	Labels per roll	Rec. ribbon
i3300, i5300, BBP33	Fig. 1	B33-5-424	White	1.000 (25.4)	0.500 (12.7)	1.075 (27.3)	0.600 (15.2)	3.350 (85.0)	3	9000	B30-R4300
i3300, i5300, BBP33	Fig. 1	B33-37-424	White	1.500 (38.1)	0.500 (12.7)	1.650 (41.9)	0.600 (15.2)	3.350 (85.1)	2	6000	B30-R4300
i3300, i5300, BBP33	Fig. 1	B33-6-424	White	1.500 (38.1)	0.750 (19.1)	1.650 (41.9)	0.875 (22.2)	3.350 (85.1)	2	4000	B30-R4300
i3300, i5300, BBP33	Fig. 2	B33-53-424	White	2.000 (50.8)	0.500 (12.7)	-	0.600 (15.2)	2.200 (55.9)	1	2500	B30-R4300
i3300, i5300, BBP33	Fig. 2	B33-17-424	White	2.000 (50.8)	1.000 (25.4)	1.125 (28.6)	2.200 (55.9)	-	1	1500	B30-R4300
i3300, i5300, BBP33	Fig. 2	B33-7-424	White	2.750 (69.9)	1.250 (31.8)	-	1.375 (34.9)	2.950 (74.9)	1	1000	B30-R4300
i3300, i5300, BBP33	Fig. 2	B33-18-424	White	3.000 (76.2)	1.000 (25.4)	1.125 (28.6)	3.200 (81.3)	-	1	1500	B30-R4300
i3300, i5300, S3000, S3100, BBP30, BBP31, BBP33, BBP35, BBP37	Fig. 3a	B30C-3000-424	White	3.000 (76.2)	150 ft. (45.8m)	-	-	3.250 (82.6)	1 roll (cont.)		B30-R4300
i3300, i5300, BBP33	Fig. 2	B33-19-424	White	3.000 (76.2)	2.000 (50.8)	2.125 (54.0)	3.200 (81.3)	-	1	500	B30-R4300
i3300, i5300, BBP33	Fig. 2	B33-20-424	White	3.000 (76.2)	5.000 (127)	-	5.125 (130.2)	3.200 (81.3)	1	250	B30-R4300
i3300, i5300, S3000, S3100, BBP30, BBP31, BBP33, BBP35, BBP37	Fig. 3a	B30C-4000-424	White	4.000 (101.6)	150 ft. (45.8 m)	-	-	4.200 (106.7)	1 roll (cont.)		B30-R4300
i3300, i5300, BBP33	Fig. 2	B33-55-424	White	4.000 (101.6)	2.000 (50.8)	-	2.125 (54.0)	4.200 (106.7)	1	750	B30-R4300
i3300, i5300, BBP33	Fig. 2	B33-25-424	White	4.000 (101.6)	6.000 (152.4)	6.125 (155.6)	4.200 (106.7)	-	1	350	B30-R4300

Direct Thermal Paper Labels

(B-813, B-816)

- Economical choice for light-duty printing with added benefit of ribbonless printing
- Standard matte white finish
- Permanent and removable adhesive choices
- Compatible with i5300 printer ONLY

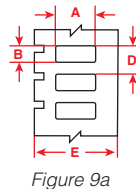

For Use with Printers:	Diagram	Catalog #	Color	Label width A inch (mm)	Label height B inch (mm)	Horiz. repeat C inch (mm)	Vert. repeat D inch (mm)	Web width E inch (mm)	Datum Edge F inch (mm)	Labels per row	Labels per roll
Matte white direct thermal paper (B-813)											
i5300	Fig. 9a	B33-330-813	Matte White	3.000 (76.2)	1.000 (25.4)	-	1.125 (28.6)	4.250 (108.0)	0.625 (15.9)	1	1450
i5300	Fig. 9a	B33-332-813	Matte White	3.000 (76.2)	2.000 (50.8)	-	2.125 (54.0)	4.250 (108.0)	0.625 (15.9)	1	775
i5300	Fig. 9a	B33-331-813	Matte White	3.000 (76.2)	5.000 (127.0)	-	5.125 (103.2)	4.250 (108.0)	0.625 (15.9)	1	325
i5300	Fig. 9a	B33-334-813	Matte White	4.000 (101.6)	2.000 (50.8)	-	2.125 (54.0)	4.250 (108.0)	0.125 (3.2)	1	775
i5300	Fig. 9a	B33-333-813	Matte White	4.000 (101.6)	6.000 (152.4)	-	6.125 (155.6)	4.250 (108.0)	0.125 (3.2)	1	270
Matte white direct thermal paper with removable adhesive (B-816)											
i5300	Fig. 9a	B33-330-816	Matte White	3.000 (76.2)	1.000 (25.4)	-	1.125 (28.6)	4.250 (108.0)	0.625 (15.9)	1	1450
i5300	Fig. 9a	B33-332-816	Matte White	3.000 (76.2)	2.000 (50.8)	-	2.125 (54.0)	4.250 (108.0)	0.625 (15.9)	1	775
i5300	Fig. 9a	B33-331-816	Matte White	3.000 (76.2)	5.000 (127.0)	-	5.125 (103.2)	4.250 (108.0)	0.625 (15.9)	1	325
i5300	Fig. 9a	B33-334-816	Matte White	4.000 (101.6)	2.000 (50.8)	-	2.125 (54.0)	4.250 (108.0)	0.125 (3.2)	1	775
i5300	Fig. 9a	B33-333-816	Matte White	4.000 (101.6)	6.000 (152.4)	-	6.125 (155.6)	4.250 (108.0)	0.125 (3.2)	1	270

High-Temp Polyimide Labels (B-727, B-728, B-729)

- For pre-process circuit board identification
- Designed to withstand processes, fluxes and solvents used in circuit board manufacturing
- Consult technical data sheet for detailed performance, compliance and ribbon usage information

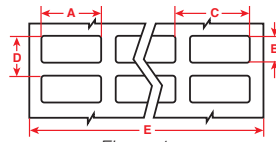

Figure 1

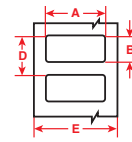

Figure 2

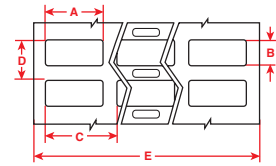

Figure 1d

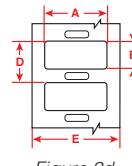
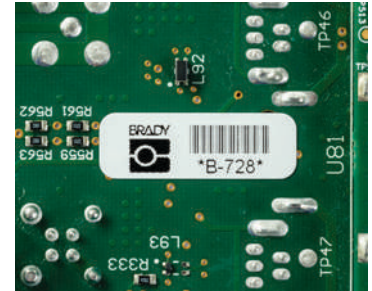

Figure 2d



For Use with Printers:	Diagram	Catalog #	Color	Label width A Inch (mm)	Label height B Inch (mm)	Horiz. repeat C Inch (mm)	Vert. repeat D Inch (mm)	Web width E Inch (mm)	Labels per row	Labels per roll	Rec. ribbon
High-temp gloss polyimide (B-727)											
i3300, i5300, BBP33	Fig. 1	B33-70-727	Gloss White	0.250 (6.4)	0.250 (6.4)	0.320 (8.1)	0.350 (8.9)	2.370 (60.1)	7	20000	B30-R6000
i3300, i5300, BBP33	Fig. 1	B33-11-727	Gloss White	0.250 (6.35)	0.250 (6.4)	0.250 (6.4)	0.375 (9.5)	3.200 (81.3)	12	5000	B30-R6000
i3300, i5300, BBP33	Fig. 1	B33-71-727	Gloss White	0.315 (8.0)	0.315 (8.0)	0.375 (9.5)	0.450 (11.4)	2.390 (60.7)	6	20000	B30-R6000
i3300, i5300, BBP33	Fig. 1	B33-340-727	Gloss White	0.375 (9.5)	0.375 (9.5)	0.438 (11.1)	0.475 (12.1)	3.500 (88.9)	7	10000	B30-R6000
i3300, i5300, BBP33	Fig. 1	B33-12-727	Gloss White	0.500 (12.7)	0.437 (11.0)	0.662 (16.8)	0.537 (13.6)	3.350 (85.1)	5	10000	B30-R6000
i3300, i5300, BBP33	Fig. 1	B33-149-727	Gloss White	0.500 (12.7)	0.500 (12.7)	0.600 (15.2)	0.600 (15.2)	2.500 (63.5)	4	5000	B30-R6000
i5300	Fig. 2d	B33-342-727	Gloss White	0.650 (16.5)	0.200 (5.0)	-	0.325 (8.2)	0.850 (21.5)	1	3700	B30-R6000
i5300	Fig. 1d	B33-341-727	Gloss White	0.650 (16.5)	0.200 (5.0)	0.700 (17.7)	0.325 (8.2)	2.950 (74.9)	4	10000	B30-R6000
i3300, i5300, BBP33	Fig. 1	B33-1-727	Gloss White	0.750 (19.1)	0.250 (6.4)	0.800 (20.3)	0.350 (8.9)	3.350 (85.1)	4	5000	B30-R6000
i3300, i5300, BBP33	Fig. 2	B33-49-727	Gloss White	0.900 (22.9)	0.250 (6.4)	-	0.350 (8.9)	1.100 (27.9)	1	5000	B30-R6000
i3300, i5300, BBP33	Fig. 1	B33-2-727	Gloss White	0.900 (22.9)	0.250 (6.4)	1.125 (28.6)	0.350 (8.9)	3.350 (85.1)	3	5000	B30-R6000
i3300, i5300, BBP33	Fig. 1	B33-51-727	Gloss White	1.000 (25.4)	0.250 (6.4)	1.075 (27.3)	0.350 (8.9)	3.350 (85.1)	3	10000	B30-R6000
i3300, i5300, BBP33	Fig. 2	B33-103-727	Gloss White	1.000 (25.4)	0.250 (6.4)	-	0.350 (8.9)	1.200 (30.5)	1	5000	B30-R6000
i3300, i5300, BBP33	Fig. 2	B33-58-727	Gloss White	1.000 (25.4)	0.375 (9.5)	-	0.475 (12.1)	1.200 (30.5)	1	4000	B30-R6000
i3300, i5300, BBP33	Fig. 1	B33-3-727	Gloss White	1.000 (25.4)	0.375 (9.5)	1.075 (27.3)	0.475 (12.1)	3.350 (85.1)	3	10000	B30-R6000
i3300, i5300, BBP33	Fig. 2	B33-59-727	Gloss White	1.000 (25.4)	0.500 (12.7)	-	0.600 (15.2)	1.200 (30.5)	1	2500	B30-R6000
i3300, i5300, BBP33	Fig. 1	B33-5-727	Gloss White	1.000 (25.4)	0.500 (12.7)	1.075 (27.3)	0.600 (15.2)	3.350 (85.1)	3	7000	B30-R6000
i3300, i5300, BBP33	Fig. 1	B33-13-727	Gloss White	1.250 (31.8)	0.250 (6.4)	1.300 (33.0)	0.375 (9.5)	2.750 (69.9)	2	5000	B30-R6000
i3300, i5300, BBP33	Fig. 2	B33-43-727	Gloss White	1.250 (31.8)	0.250 (6.4)	-	0.350 (8.9)	1.450 (36.8)	1	5000	B30-R6000
i3300, i5300, BBP33	Fig. 2	B33-44-727	Gloss White	1.375 (34.9)	0.250 (6.4)	-	0.350 (8.9)	1.600 (40.6)	1	5000	B30-R6000
i3300, i5300, BBP33	Fig. 1	B33-4-727	Gloss White	1.500 (38.1)	0.250 (6.4)	1.650 (41.9)	0.350 (8.9)	3.350 (85.1)	2	10000	B30-R6000
i3300, i5300, BBP33	Fig. 2	B33-45-727	Gloss White	1.500 (38.1)	0.250 (6.4)	-	0.350 (8.9)	1.700 (43.2)	1	5000	B30-R6000
i3300, i5300, BBP33	Fig. 2	B33-72-727	Gloss White	1.750 (44.5)	0.250 (6.4)	-	0.350 (8.9)	1.950 (49.5)	1	5000	B30-R6000
i3300, i5300, BBP33	Fig. 2	B33-15-727	Gloss White	2.000 (50.8)	0.250 (6.4)	-	0.375 (9.5)	2.200 (55.9)	1	3200	B30-R6000
i3300, i5300, S3000, S3100, BBP30, BBP31, BBP33, BBP35, BBP37	Fig. 3	B30C-4000-727	Gloss White	4.000 (101.6)	100 ft. (30.5 m)	-	-	4.200 (106.7)	1 roll (cont.)		B30-R6000
High-temp matte polyimide for solder ball reduction (B-728)											
i3300, i5300, BBP33	Fig. 1	B33-70-728	Matte White	0.250 (6.4)	0.250 (6.4)	0.320 (8.1)	0.350 (8.9)	2.370 (60.1)	7	20000	B30-R6000
i3300, i5300, BBP33	Fig. 1	B33-340-728	Matte White	0.375 (9.5)	0.375 (9.5)	0.438 (11.1)	0.475 (12.1)	3.500 (88.9)	7	10000	B30-R6000
i3300, i5300, BBP33	Fig. 1	B33-12-728	Matte White	0.500 (12.7)	0.437 (11.0)	0.662 (16.8)	0.537 (13.6)	3.350 (85.1)	5	10000	B30-R6000
i5300	Fig. 1d	B33-341-728	Matte White	0.650 (16.5)	0.200 (5.0)	0.700 (17.7)	0.325 (8.2)	2.950 (74.9)	4	10000	B30-R6000
i3300, i5300, BBP33	Fig. 1	B33-1-728	Matte White	0.750 (19.1)	0.250 (6.4)	0.800 (20.3)	0.350 (8.9)	3.350 (85.1)	4	10000	B30-R6000
i3300, i5300, BBP33	Fig. 1	B33-2-728	Matte White	0.900 (22.9)	0.250 (6.4)	1.125 (28.5)	0.350 (8.9)	3.350 (85.1)	3	10000	B30-R6000
i3300, i5300, BBP33	Fig. 1	B33-51-728	Matte White	1.000 (25.4)	0.250 (6.4)	1.075 (27.3)	0.350 (8.9)	3.350 (85.1)	3	10000	B30-R6000
i3300, i5300, BBP33	Fig. 2	B33-103-728	Matte White	1.000 (25.4)	0.250 (6.4)	-	0.350 (8.9)	1.200 (30.4)	1	4000	B30-R6000
i3300, i5300, BBP33	Fig. 1	B33-5-728	Matte White	1.000 (25.4)	0.500 (12.7)	1.075 (27.3)	0.600 (15.2)	3.350 (85.1)	3	7000	B30-R6000
i3300, i5300, BBP33	Fig. 1	B33-13-728	Matte White	1.250 (31.8)	0.250 (6.4)	1.300 (33.0)	0.375 (9.5)	2.750 (69.9)	2	7000	B30-R6000
i3300, i5300, BBP33	Fig. 2	B33-43-728	Matte White	1.250 (31.8)	0.250 (6.4)	-	0.350 (8.9)	1.450 (36.8)	1	4000	B30-R6000
i3300, i5300, BBP33	Fig. 1	B33-4-728	Matte White	1.500 (38.1)	0.250 (6.4)	1.650 (41.9)	0.350 (8.9)	3.350 (85.1)	2	8000	B30-R6000
Ultra-thin high-temp matte polyimide for solderball reduction (B-729)											
i3300, i5300, BBP33	Fig. 1	B33-70-729	Matte White	0.250 (6.4)	0.250 (6.4)	0.320 (8.1)	0.350 (8.9)	2.370 (60.1)	7	20000	B30-R6000
i3300, i5300, BBP33	Fig. 1	B33-340-729	Matte White	0.375 (9.5)	0.375 (9.5)	0.438 (11.1)	0.475 (12.1)	3.500 (88.9)	7	10000	B30-R6000
i3300, i5300, BBP33	Fig. 1	B33-12-729	Matte White	0.500 (12.7)	0.437 (11.0)	0.662 (16.8)	0.537 (13.6)	3.350 (85.1)	5	10000	B30-R6000
i5300	Fig. 1d	B33-341-729	Matte White	0.650 (16.5)	0.200 (5.0)	0.700 (17.7)	0.325 (8.2)	2.950 (74.9)	4	10000	B30-R6000
i3300, i5300, BBP33	Fig. 1	B33-1-729	Matte White	0.750 (19.1)	0.250 (6.4)	0.800 (20.3)	0.350 (8.9)	3.350 (85.1)	4	10000	B30-R6000
i3300, i5300, BBP33	Fig. 1	B33-2-729	Matte White	0.900 (22.9)	0.250 (6.4)	1.125 (28.5)	0.350 (8.9)	3.350 (85.1)	3	10000	B30-R6000
i3300, i5300, BBP33	Fig. 1	B33-51-729	Matte White	1.000 (25.4)	0.250 (6.4)	1.075 (27.3)	0.350 (8.9)	3.350 (85.1)	3	10000	B30-R6000
i3300, i5300, BBP33	Fig. 2	B33-103-729	Matte White	1.000 (25.4)	0.250 (6.4)	-	0.350 (8.9)	1.200 (30.4)	1	4000	B30-R6000
i3300, i5300, BBP33	Fig. 1	B33-5-729	Matte White	1.000 (25.4)	0.500 (12.7)	1.075 (27.3)	0.600 (15.2)	3.350 (85.1)	3	7000	B30-R6000
i3300, i5300, BBP33	Fig. 1	B33-13-729	Matte White	1.250 (31.8)	0.250 (6.4)	1.300 (33.0)	0.375 (9.5)	2.750 (69.9)	2	7000	B30-R6000
i3300, i5300, BBP33	Fig. 2	B33-43-729	Matte White	1.250 (31.8)	0.250 (6.4)	-	0.350 (8.9)	1.450 (36.8)	1	4000	B30-R6000
i3300, i5300, BBP33	Fig. 1	B33-4-729	Matte White	1.500 (38.1)	0.250 (6.4)	1.650 (41.9)	0.350 (8.9)	3.350 (85.1)	2	8000	B30-R6000

High-Temp Electrostatic Dissipative Polyimide Labels (B-717, B-718, B-719)

- For pre-process circuit board identification where static dissipative properties are required
- Materials feature both a permanent static dissipative adhesive and static dissipative release liner
- Designed to withstand processes, fluxes and solvents used in curcuit board manufacturing
- UL969 rated, consult technical data sheet for complete performance and ribbon usage criteria

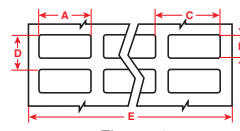

Figure 1

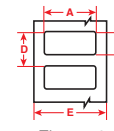

Figure 2

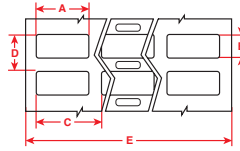

Figure 1d

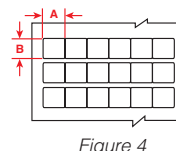

Figure 4



For Use with Printers:	Diagram	Catalog #	Color	Label width A inch (mm)	Label height B inch (mm)	Horiz. repeat C inch (mm)	Vert. repeat D inch (mm)	Web width E inch (mm)	Labels per row	Labels per roll	Rec. ribbon
Electrostatic dissipative gloss polyimide (B-717)											
i3300, i5300, BBP33	Fig. 1	B33-70-717	Gloss White	0.250 (6.4)	0.250 (6.4)	0.320 (8.1)	0.350 (8.9)	2.370 (60.1)	7	20000	B30-R6000
i3300, i5300, BBP33	Fig. 1	B33-340-717	Gloss White	0.375 (9.5)	0.375 (9.5)	0.438 (11.1)	0.475 (12.1)	3.500 (88.9)	7	10000	B30-R6000
i3300, i5300, BBP33	Fig. 1	B33-12-717	Gloss White	0.500 (12.7)	0.437 (11.0)	0.662 (16.8)	0.537 (13.6)	3.350 (85.1)	5	10000	B30-R6000
i5300	Fig. 1d	B33-341-717	Gloss White	0.650 (16.5)	0.200 (5.0)	0.700 (17.7)	0.325 (8.2)	2.950 (74.9)	4	10000	B30-R6000
i3300, i5300, BBP33	Fig. 1	B33-1-717	Gloss White	0.750 (19.1)	0.250 (6.4)	0.800 (20.3)	0.350 (8.9)	3.350 (85.1)	4	10000	B30-R6000
i3300, i5300, BBP33	Fig. 2	B33-46-717	Gloss White	0.750 (19.1)	0.250 (6.4)	-	0.350 (8.9)	0.950 (24.1)	1	5000	B30-R6000
i3300, i5300, BBP33	Fig. 1	B33-2-717	Gloss White	0.900 (22.9)	0.250 (6.4)	1.125 (28.5)	0.350 (8.9)	3.350 (85.1)	3	10000	B30-R6000
i3300, i5300, BBP33	Fig. 1	B33-51-717	Gloss White	1.000 (25.4)	0.250 (6.4)	1.075 (27.3)	0.350 (8.9)	3.350 (85.1)	3	10000	B30-R6000
i3300, i5300, BBP33	Fig. 2	B33-103-717	Gloss White	1.000 (25.4)	0.250 (6.4)	-	0.350 (8.9)	1.200 (30.5)	1	5000	B30-R6000
i3300, i5300, BBP33	Fig. 1	B33-5-717	Gloss White	1.000 (25.4)	0.500 (12.7)	1.075 (27.3)	0.600 (15.2)	3.350 (85.1)	3	7000	B30-R6000
i3300, i5300, BBP33	Fig. 1	B33-13-717	Gloss White	1.250 (31.8)	0.250 (6.4)	1.300 (33.0)	0.375 (9.5)	2.750 (69.9)	2	7000	B30-R6000
i3300, i5300, BBP33	Fig. 2	B33-43-717	Gloss White	1.250 (31.8)	0.250 (6.4)	-	0.350 (8.9)	1.450 (36.8)	1	5000	B30-R6000
i3300, i5300, BBP33	Fig. 1	B33-4-717	Gloss White	1.500 (38.1)	0.250 (6.4)	1.650 (41.9)	0.350 (8.9)	3.350 (85.1)	2	8000	B30-R6000
i3300, i5300, BBP33	Fig. 2	B33-45-717	Gloss White	1.500 (38.1)	0.250 (6.4)	-	0.350 (8.9)	1.700 (43.2)	1	5000	B30-R6000
Ultra-thin electrostatic dissipative gloss polyimide (B-718)											
i3300, i5300, BBP33	Fig. 4	B33-11-718	Gloss White	0.250 (6.4)	0.250 (6.4)	0.250 (6.4)	0.375 (9.5)	3.200 (81.3)	12	1500	B30-R6000
i3300, i5300, BBP33	Fig. 1	B33-340-718	Gloss White	0.375 (9.5)	0.375 (9.5)	0.438 (11.1)	0.475 (12.1)	3.500 (88.9)	7	10000	B30-R6000
i3300, i5300, BBP33	Fig. 1	B33-12-718	Gloss White	0.500 (12.7)	0.437 (11.0)	0.662 (16.8)	0.537 (13.6)	3.350 (85.1)	5	10000	B30-R6000
i3300, i5300, BBP33	Fig. 1	B33-149-718	Gloss White	0.500 (12.7)	0.500 (12.7)	0.600 (15.2)	0.600 (15.2)	2.500 (63.5)	4	5000	B30-R6000
i5300	Fig. 1d	B33-341-718	Gloss White	0.650 (16.5)	0.200 (5.0)	0.700 (17.7)	0.325 (8.2)	2.950 (74.9)	4	10000	B30-R6000
i3300, i5300, BBP33	Fig. 1	B33-1-718	Gloss White	0.750 (19.1)	0.250 (6.4)	0.800 (20.3)	0.350 (8.9)	3.350 (85.1)	4	5000	B30-R6000
i3300, i5300, BBP33	Fig. 2	B33-46-718	Gloss White	0.750 (19.1)	0.250 (6.4)	-	0.350 (8.9)	0.950 (24.1)	1	5000	B30-R6000
i3300, i5300, BBP33	Fig. 1	B33-2-718	Gloss White	0.900 (22.9)	0.250 (6.4)	1.125 (28.5)	0.350 (8.9)	3.350 (85.1)	3	10000	B30-R6000
i3300, i5300, BBP33	Fig. 2	B33-49-718	Gloss White	0.900 (22.9)	0.250 (6.4)	-	0.350 (8.9)	1.100 (27.9)	1	5000	B30-R6000
i3300, i5300, BBP33	Fig. 1	B33-51-718	Gloss White	1.000 (25.4)	0.250 (6.4)	1.075 (27.3)	0.350 (8.9)	3.350 (85.1)	3	10000	B30-R6000
i3300, i5300, BBP33	Fig. 2	B33-103-718	Gloss White	1.000 (25.4)	0.250 (6.4)	-	0.350 (8.9)	1.200 (30.4)	1	4000	B30-R6000
i3300, i5300, BBP33	Fig. 1	B33-3-718	Gloss White	1.000 (25.4)	0.375 (9.5)	1.075 (27.3)	0.475 (12.1)	3.350 (85.1)	3	10000	B30-R6000
i3300, i5300, BBP33	Fig. 1	B33-5-718	Gloss White	1.000 (25.4)	0.500 (12.7)	1.075 (27.3)	0.600 (15.2)	3.350 (85.1)	3	10000	B30-R6000
i3300, i5300, BBP33	Fig. 1	B33-13-718	Gloss White	1.250 (31.8)	0.250 (6.4)	1.300 (33.0)	0.375 (9.5)	2.750 (69.9)	2	7000	B30-R6000
i3300, i5300, BBP33	Fig. 2	B33-43-718	Gloss White	1.250 (31.8)	0.250 (6.4)	-	0.350 (8.9)	1.450 (36.8)	1	5000	B30-R6000
i3300, i5300, BBP33	Fig. 1	B33-4-718	Gloss White	1.500 (38.1)	0.250 (6.4)	1.650 (41.9)	0.350 (8.9)	3.350 (85.1)	2	8000	B30-R6000
i3300, i5300, BBP33	Fig. 2	B33-45-718	Gloss White	1.500 (38.1)	0.250 (6.4)	-	0.350 (8.9)	1.700 (43.2)	1	5000	B30-R6000
i3300, i5300, BBP33	Fig. 2	B33-72-718	Gloss White	1.750 (44.5)	0.250 (6.4)	-	0.350 (8.9)	1.950 (49.5)	1	5000	B30-R6000
i3300, i5300, BBP33	Fig. 2	B33-15-718	Gloss White	2.000 (50.8)	0.250 (6.4)	-	0.375 (9.5)	2.200 (55.9)	1	3200	B30-R6000
Ultra-thin electrostatic dissipative matte polyimide for solderball reduction (B-719)											
i3300, i5300, BBP33	Fig. 1	B33-70-719	Matte White	0.250 (6.4)	0.250 (6.4)	0.320 (8.1)	0.350 (8.9)	2.370 (60.1)	7	20000	B30-R6000
i3300, i5300, BBP33	Fig. 1	B33-340-719	Matte White	0.375 (9.5)	0.375 (9.5)	0.438 (11.1)	0.475 (12.1)	3.500 (88.9)	7	10000	B30-R6000
i3300, i5300, BBP33	Fig. 1	B33-12-719	Matte White	0.500 (12.7)	0.437 (11.0)	0.662 (16.8)	0.537 (13.6)	3.350 (85.1)	5	10000	B30-R6000
i5300	Fig. 1d	B33-341-719	Matte White	0.650 (16.5)	0.200 (5.0)	0.700 (17.7)	0.325 (8.2)	2.950 (74.9)	4	10000	B30-R6000
i3300, i5300, BBP33	Fig. 1	B33-1-719	Matte White	0.750 (19.1)	0.250 (6.4)	0.800 (20.3)	0.350 (8.9)	3.350 (85.1)	4	10000	B30-R6000
i3300, i5300, BBP33	Fig. 2	B33-46-719	Matte White	0.750 (19.1)	0.250 (6.4)	-	0.350 (8.9)	0.950 (24.1)	1	5000	B30-R6000
i3300, i5300, BBP33	Fig. 1	B33-2-719	Matte White	0.900 (22.9)	0.250 (6.4)	1.125 (28.6)	0.350 (8.9)	3.350 (85.1)	3	5000	B30-R6000
i3300, i5300, BBP33	Fig. 1	B33-51-719	Matte White	1.000 (25.4)	0.250 (6.4)	1.075 (27.3)	0.350 (8.9)	3.350 (85.1)	3	10000	B30-R6000
i3300, i5300, BBP33	Fig. 2	B33-103-719	Matte White	1.000 (25.4)	0.250 (6.4)	-	0.350 (8.9)	1.200 (30.4)	1	4000	B30-R6000
i3300, i5300, BBP33	Fig. 1	B33-5-719	Matte White	1.000 (25.4)	0.500 (12.7)	1.075 (27.3)	0.600 (15.2)	3.350 (85.1)	3	7000	B30-R6000
i3300, i5300, BBP33	Fig. 1	B33-13-719	Matte White	1.250 (31.8)	0.250 (6.4)	1.300 (33.0)	0.375 (9.5)	2.750 (69.9)	2	7000	B30-R6000
i3300, i5300, BBP33	Fig. 2	B33-43-719	Matte White	1.250 (31.8)	0.250 (6.4)	-	0.350 (8.9)	1.450 (36.8)	1	5000	B30-R6000
i3300, i5300, BBP33	Fig. 1	B33-4-719	Matte White	1.500 (38.1)	0.250 (6.4)	1.650 (41.9)	0.350 (8.9)	3.350 (85.1)	2	8000	B30-R6000
i3300, i5300, BBP33	Fig. 1	B33-13-729	Matte White	1.250 (31.8)	0.250 (6.4)	1.300 (33.0)	0.375 (9.5)	2.750 (69.9)	2	7000	B30-R6000
i3300, i5300, BBP33	Fig. 2	B33-43-729	Matte White	1.250 (31.8)	0.250 (6.4)	-	0.350 (8.9)	1.450 (36.8)	1	4000	B30-R6000
i3300, i5300, BBP33	Fig. 1	B33-4-729	Matte White	1.500 (38.1)	0.250 (6.4)	1.650 (41.9)	0.350 (8.9)	3.350 (85.1)	2	8000	B30-R6000

Ultra High-Temp Matte Amber Polyimide Labels (B-724)

- For pre-process circuit board identification
- Extremely high temperature resistance for top or bottom-side board and component ID
- Designed to withstand processes, fluxes and solvents used in circuit board manufacturing
- Consult technical data sheet for complete performance and ribbon usage criteria

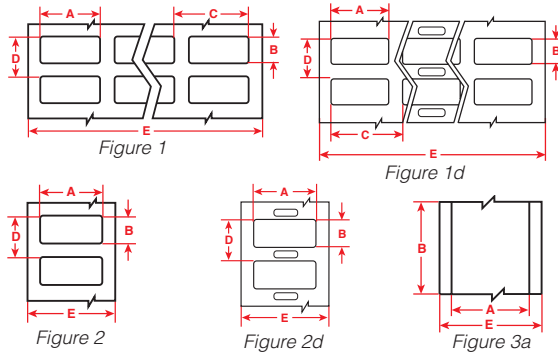

For Use with Printers:	Diagram	Catalog #	Color	Label width A inch (mm)	Label height B inch (mm)	Horiz. repeat C inch (mm)	Vert. repeat D inch (mm)	Web width E inch (mm)	Labels per row	Labels per roll	Rec. ribbon
i3300, i5300, BBP33	Fig. 1	B33-340-724	Matte Amber	0.375 (9.5)	0.375 (9.5)	0.438 (11.1)	0.475 (12.1)	3.500 (88.9)	7	10000	B30-R4300
i5300	Fig. 2d	B33-344-724	Matte Amber	0.500 (0.0)	0.200 (0.0)	-	0.325 (8.2)	0.850 (21.6)	1	3700	B30-R4300
i3300, i5300, BBP33	Fig. 1	B33-12-724	Matte Amber	0.500 (12.7)	0.437 (11.0)	0.662 (16.8)	0.537 (13.6)	3.350 (85.1)	5	10000	B30-R4300
i3300, i5300, BBP33	Fig. 1	B33-149-724	Matte Amber	0.500 (12.7)	0.500 (12.7)	0.600 (15.2)	0.600 (15.2)	2.500 (63.5)	4	5000	B30-R4300
i5300	Fig. 2d	B33-342-724	Matte Amber	0.650 (0.0)	0.200 (0.0)	-	0.325 (8.2)	0.850 (21.5)	1	3700	B30-R4300
i5300	Fig. 1d	B33-341-724	Matte Amber	0.650 (16.5)	0.200 (5.0)	0.700 (17.7)	0.325 (8.2)	2.950 (74.9)	4	10000	B30-R4300
i3300, i5300, BBP33	Fig. 2	B33-46-724	Matte Amber	0.750 (19.1)	0.250 (6.4)	-	0.350 (8.9)	0.950 (24.1)	1	5000	B30-R4300
i3300, i5300, BBP33	Fig. 1	B33-1-724	Matte Amber	0.750 (19.1)	0.250 (6.4)	0.800 (20.3)	0.350 (8.9)	3.350 (85.1)	4	5000	B30-R4300
i3300, i5300, BBP33	Fig. 1	B33-2-724	Matte Amber	0.900 (22.9)	0.250 (6.4)	1.125 (28.6)	0.350 (8.9)	3.350 (85.1)	3	5000	B30-R4300
i3300, i5300, BBP33	Fig. 1	B33-51-724	Matte Amber	1.000 (25.4)	0.250 (6.4)	1.075 (27.3)	0.350 (8.9)	3.350 (85.1)	3	10000	B30-R4300
i3300, i5300, BBP33	Fig. 2	B33-103-724	Matte Amber	1.000 (25.4)	0.250 (6.4)	-	0.350 (8.9)	1.200 (30.4)	1	4000	B30-R4300
i3300, i5300, BBP33	Fig. 1	B33-5-724	Matte Amber	1.000 (25.4)	0.500 (12.7)	1.075 (27.3)	0.600 (15.2)	3.350 (85.1)	3	7000	B30-R4300
i3300, i5300, BBP33	Fig. 1	B33-13-724	Matte Amber	1.250 (31.8)	0.250 (6.4)	1.300 (33.0)	0.375 (9.5)	2.750 (69.9)	2	7000	B30-R4300
i3300, i5300, BBP33	Fig. 2	B33-43-724	Matte Amber	1.250 (31.8)	0.250 (6.4)	-	0.350 (8.9)	1.450 (36.8)	1	5000	B30-R4300
i3300, i5300, BBP33	Fig. 1	B33-4-724	Matte Amber	1.500 (38.1)	0.250 (6.4)	-	0.350 (8.9)	3.350 (85.1)	2	5000	B30-R4300
i3300, i5300, S3000, S3100, BBP30, BBP31, BBP33, BBP35, BBP37	Fig. 3a	B30C-4000-724	Matte Amber	4.000 (101.6)	100 ft. (30.5 m)	-	-	4.200 (106.7)	1 roll (cont.)		B30-R4300

Non-Reflow High-Temp Polyimide Labels (B-777)

- For pre-process circuit board identification
- Does not require pre-heating for repeat exposure to harsh processes
- Designed to withstand processes, fluxes and solvents used in circuit board manufacturing
- Consult technical data sheet for complete performance and ribbon usage criteria

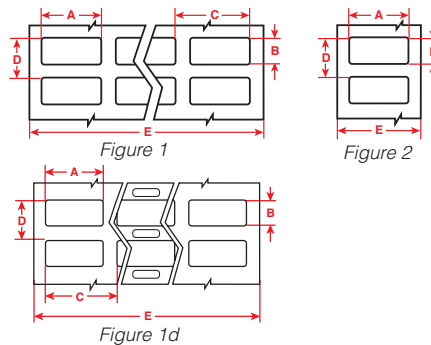

For Use with Printers:	Diagram	Catalog #	Color	Label width A inch (mm)	Label height B inch (mm)	Horiz. repeat C inch (mm)	Vert. repeat D inch (mm)	Web width E inch (mm)	Labels per row	Labels per roll	Rec. ribbon
i3300, i5300, BBP33	Fig. 1	B33-70-777	White	0.250 (6.4)	0.250 (6.4)	0.320 (8.1)	0.350 (8.9)	2.370 (60.1)	7	20000	B30-R6300
i3300, i5300, BBP33	Fig. 1	B33-340-777	White	0.375 (9.5)	0.375 (9.5)	0.438 (11.1)	0.475 (12.1)	3.500 (88.9)	7	10000	B30-R6300
i3300, i5300, BBP33	Fig. 1	B33-12-777	White	0.500 (12.7)	0.437 (11.0)	0.662 (16.8)	0.537 (13.6)	3.350 (85.1)	5	10000	B30-R6300
i5300	Fig. 1d	B33-341-777	White	0.650 (16.5)	0.200 (5.0)	0.700 (17.7)	0.325 (8.2)	2.950 (74.9)	4	10000	B30-R6300
i3300, i5300, BBP33	Fig. 1	B33-1-777	White	0.750 (19.1)	0.250 (6.4)	0.800 (20.3)	0.350 (8.9)	3.350 (85.1)	4	10000	B30-R6300
i3300, i5300, BBP33	Fig. 1	B33-2-777	White	0.900 (22.9)	0.250 (6.4)	1.125 (28.5)	0.350 (8.9)	3.350 (85.1)	3	10000	B30-R6300
i3300, i5300, BBP33	Fig. 1	B33-51-777	White	1.000 (25.4)	0.250 (6.4)	1.075 (27.3)	0.350 (8.9)	3.350 (85.1)	3	10000	B30-R6300
i3300, i5300, BBP33	Fig. 2	B33-103-777	White	1.000 (25.4)	0.250 (6.4)	-	0.350 (8.9)	1.200 (30.4)	1	4000	B30-R6300
i3300, i5300, BBP33	Fig. 1	B33-5-777	White	1.000 (25.4)	0.500 (12.7)	1.075 (27.3)	0.600 (15.2)	3.350 (85.1)	3	7000	B30-R6300
i3300, i5300, BBP33	Fig. 1	B33-13-777	White	1.250 (31.8)	0.250 (6.4)	1.300 (33.0)	0.375 (9.5)	2.750 (69.9)	2	7000	B30-R6300
i3300, i5300, BBP33	Fig. 2	B33-43-777	White	1.250 (31.8)	0.250 (6.4)	-	0.350 (8.9)	1.450 (36.8)	1	4000	B30-R6300
i3300, i5300, BBP33	Fig. 1	B33-4-777	White	1.500 (38.1)	0.250 (6.4)	1.650 (41.9)	0.350 (8.9)	3.350 (85.1)	2	8000	B30-R6300

Raised Profile Labels – Engraved Plate Substitutes – Push Button Style

(B-593)

- Costs up to 80% less than engraved legend plates
- High gloss, polyester label with thick raised profile and ultra-aggressive adhesive (0.70 mm thick)
- High-performance, low-cost substitute to engraved plates
- 10-year outdoor durability rating
- 5 push button sizes (including keyed and non-keyed 22.5 mm and 30.5 mm hole dia. keyed)

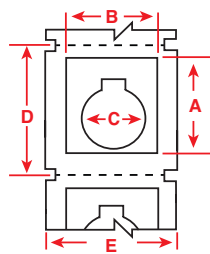
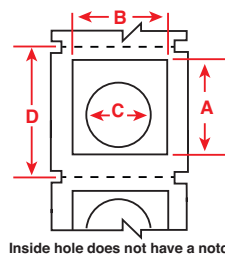

Figure 18a



Inside hole does not have a notch

Figure 18b



For Use with Printers:	Diagram	Catalog #	Color	Label width A inch (mm)	Label height B inch (mm)	Horiz. repeat C inch (mm)	Vert. repeat D inch (mm)	Web width E inch (mm)	Labels per row	Labels per roll	Rec. ribbon
3300, i5300, S3000, S3100, BBP30, BBP31, BBP33, BBP35, BBP37	Fig. 18a	B30EP-167-593-WT	White	1.500 (38.1)	1.200 (30.5)	0.885 (22.5)	1.750 (44.5)	2.500 (63.5)	1	200	B30-R6000
3300, i5300, S3000, S3100, BBP30, BBP31, BBP33, BBP35, BBP37	Fig. 18b	B30EP-167U-593-WT	White	1.500 (38.1)	1.200 (30.5)	0.885 (22.5)	1.750 (44.5)	2.500 (63.5)	1	200	B30-R6000
3300, i5300, S3000, S3100, BBP30, BBP31, BBP33, BBP35, BBP37	Fig. 18a	B30EP-169-593-WT	White	1.800 (45.7)	1.800 (45.7)	1.200 (30.5)	2.000 (50.8)	2.500 (63.5)	1	190	B30-R6000
3300, i5300, S3000, S3100, BBP30, BBP31, BBP33, BBP35, BBP37	Fig. 18a	B30EP-168-593-WT	White	1.900 (48.3)	1.200 (30.5)	0.885 (22.5)	2.125 (54.0)	2.500 (63.5)	1	180	B30-R6000
3300, i5300, S3000, S3100, BBP30, BBP31, BBP33, BBP35, BBP37	Fig. 18a	B30EP-170-593-WT	White	2.400 (60.9)	2.400 (60.9)	1.200 (30.5)	2.625 (66.7)	3.250 (82.6)	1	145	B30-R6000
3300, i5300, S3000, S3100, BBP30, BBP31, BBP33, BBP35, BBP37	Fig. 18a	B30EP-167-593-YL	Yellow	1.500 (38.1)	1.200 (30.5)	0.885 (22.5)	1.750 (44.5)	2.500 (63.5)	1	200	B30-R6000
3300, i5300, S3000, S3100, BBP30, BBP31, BBP33, BBP35, BBP37	Fig. 18b	B30EP-167U-593-YL	Yellow	1.500 (38.1)	1.200 (30.5)	0.885 (22.5)	1.750 (44.5)	2.500 (63.5)	1	200	B30-R6000
3300, i5300, S3000, S3100, BBP30, BBP31, BBP33, BBP35, BBP37	Fig. 18a	B30EP-169-593-YL	Yellow	1.800 (45.7)	1.800 (45.7)	1.200 (30.5)	2.000 (50.8)	2.500 (63.5)	1	190	B30-R6000
3300, i5300, S3000, S3100, BBP30, BBP31, BBP33, BBP35, BBP37	Fig. 18a	B30EP-168-593-YL	Yellow	1.900 (48.3)	1.200 (30.5)	0.885 (22.5)	2.125 (54.0)	2.500 (63.5)	1	180	B30-R6000
3300, i5300, S3000, S3100, BBP30, BBP31, BBP33, BBP35, BBP37	Fig. 18a	B30EP-170-593-YL	Yellow	2.400 (60.9)	2.400 (60.9)	1.200 (30.5)	2.625 (66.7)	3.250 (82.6)	1	145	B30-R6000
3300, i5300, S3000, S3100, BBP30, BBP31, BBP33, BBP35, BBP37	Fig. 18a	B30EP-167-593-BK	Black	1.500 (38.1)	1.200 (30.5)	0.885 (22.5)	1.750 (44.5)	2.500 (63.5)	1	200	B30-R4400-WT
3300, i5300, S3000, S3100, BBP30, BBP31, BBP33, BBP35, BBP37	Fig. 18b	B30EP-167U-593-BK	Black	1.500 (38.1)	1.200 (30.5)	0.885 (22.5)	1.750 (44.5)	2.500 (63.5)	1	200	B30-R4400-WT
3300, i5300, S3000, S3100, BBP30, BBP31, BBP33, BBP35, BBP37	Fig. 18a	B30EP-169-593-BK	Black	1.800 (45.7)	1.800 (45.7)	1.200 (30.5)	2.000 (50.8)	2.500 (63.5)	1	190	B30-R4400-WT
3300, i5300, S3000, S3100, BBP30, BBP31, BBP33, BBP35, BBP37	Fig. 18a	B30EP-168-593-BK	Black	1.900 (48.3)	1.200 (30.5)	0.885 (22.5)	2.125 (54.0)	2.500 (63.5)	1	180	B30-R4400-WT
3300, i5300, S3000, S3100, BBP30, BBP31, BBP33, BBP35, BBP37	Fig. 18a	B30EP-170-593-BK	Black	2.400 (60.9)	2.400 (60.9)	1.200 (30.5)	2.625 (66.7)	3.250 (82.6)	1	145	B30-R4400-WT
3300, i5300, S3000, S3100, BBP30, BBP31, BBP33, BBP35, BBP37	Fig. 18a	B30EP-167-593-GN	Green	1.500 (38.1)	1.200 (30.5)	0.885 (22.5)	1.750 (44.5)	2.500 (63.5)	1	200	B30-R4400-WT
3300, i5300, S3000, S3100, BBP30, BBP31, BBP33, BBP35, BBP37	Fig. 18b	B30EP-167U-593-GN	Green	1.500 (38.1)	1.200 (30.5)	0.885 (22.5)	1.750 (44.5)	2.500 (63.5)	1	200	B30-R4400-WT
3300, i5300, S3000, S3100, BBP30, BBP31, BBP33, BBP35, BBP37	Fig. 18a	B30EP-169-593-GN	Green	1.800 (45.7)	1.800 (45.7)	1.200 (30.5)	2.000 (50.8)	2.500 (63.5)	1	190	B30-R4400-WT
3300, i5300, S3000, S3100, BBP30, BBP31, BBP33, BBP35, BBP37	Fig. 18a	B30EP-168-593-GN	Green	1.900 (48.3)	1.200 (30.5)	0.885 (22.5)	2.125 (54.0)	2.500 (63.5)	1	180	B30-R4400-WT
3300, i5300, S3000, S3100, BBP30, BBP31, BBP33, BBP35, BBP37	Fig. 18a	B30EP-170-593-GN	Green	2.400 (60.9)	2.400 (60.9)	1.200 (30.5)	2.625 (66.7)	3.250 (82.6)	1	145	B30-R4400-WT
3300, i5300, S3000, S3100, BBP30, BBP31, BBP33, BBP35, BBP37	Fig. 18a	B30EP-167-593-RD	Red	1.500 (38.1)	1.200 (30.5)	0.885 (22.5)	1.750 (44.5)	2.500 (63.5)	1	200	B30-R4400-WT
3300, i5300, S3000, S3100, BBP30, BBP31, BBP33, BBP35, BBP37	Fig. 18b	B30EP-167U-593-RD	Red	1.500 (38.1)	1.200 (30.5)	0.885 (22.5)	1.750 (44.5)	2.500 (63.5)	1	200	B30-R4400-WT
3300, i5300, S3000, S3100, BBP30, BBP31, BBP33, BBP35, BBP37	Fig. 18a	B30EP-169-593-RD	Red	1.800 (45.7)	1.800 (45.7)	1.200 (30.5)	2.000 (50.8)	2.500 (63.5)	1	190	B30-R4400-WT
3300, i5300, S3000, S3100, BBP30, BBP31, BBP33, BBP35, BBP37	Fig. 18a	B30EP-168-593-RD	Red	1.900 (48.3)	1.200 (30.5)	0.885 (22.5)	2.125 (54.0)	2.500 (63.5)	1	180	B30-R4400-WT
3300, i5300, S3000, S3100, BBP30, BBP31, BBP33, BBP35, BBP37	Fig. 18a	B30EP-170-593-RD	Red	2.400 (60.9)	2.400 (60.9)	1.200 (30.5)	2.625 (66.7)	3.250 (82.6)	1	145	B30-R4400-WT

Raised Profile Labels – Engraved Plate Substitutes – Rectangular Style (B-593)

- Costs up to 80% less than engraved legend plates
- High-gloss, polyester label with thick raised profile and ultra-aggressive adhesive (0.70 mm thick)
- Ideal for front-of-panel identification as well as inside-panel backer board labels and component identification
- Costs up to 80% less than engraved plates and prints out in about 4 seconds
- 10-year outdoor durability rating

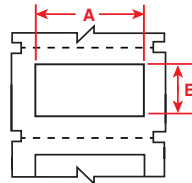

Figure 18c



For Use with Printers:	Diagram	Catalog #	Color	Label width A inch (mm)	Label height B inch (mm)	Vert. repeat D inch (mm)	Web width E inch (mm)	Labels per row	Labels per roll	Rec. ribbon
i3300, i5300, S3000, S3100, BBP30, BBP31, BBP33, BBP35, BBP37	Fig. 18c	B30EP-171-593-WT	White	1.060 (26.9)	0.490 (12.5)	0.750 (19.1)	1.375 (34.9)	1	500	B30-R6000
i3300, i5300, S3000, S3100, BBP30, BBP31, BBP33, BBP35, BBP37	Fig. 18c	B30EP-172-593-WT	White	1.770 (45.0)	0.590 (15.0)	0.850 (21.6)	2.500 (63.5)	1	450	B30-R6000
i3300, i5300, S3000, S3100, BBP30, BBP31, BBP33, BBP35, BBP37	Fig. 18c	B30EP-175-593-WT	White	3.000 (76.2)	0.750 (19.1)	1.000 (25.4)	3.250 (82.6)	1	375	B30-R6000
i3300, i5300, S3000, S3100, BBP30, BBP31, BBP33, BBP35, BBP37	Fig. 18c	B30EP-173-593-WT	White	2.000 (50.8)	1.000 (25.4)	1.250 (31.8)	2.500 (63.5)	1	300	B30-R6000
i3300, i5300, S3000, S3100, BBP30, BBP31, BBP33, BBP35, BBP37	Fig. 18c	B30EP-174-593-WT	White	4.000 (101.6)	1.000 (25.4)	1.250 (31.8)	4.250 (108.0)	1	300	B30-R6000
i3300, i5300, S3000, S3100, BBP30, BBP31, BBP33, BBP35, BBP37	Fig. 18c	B30EP-176-593-WT	White	3.000 (76.2)	1.000 (25.4)	1.250 (31.8)	3.250 (82.6)	1	300	B30-R6000
i3300, i5300, S3000, S3100, BBP30, BBP31, BBP33, BBP35, BBP37	Fig. 18c	B30EP-177-593-WT	White	3.000 (76.2)	2.500 (63.5)	2.750 (69.9)	3.250 (82.6)	1	125	B30-R6000
i3300, i5300, S3000, S3100, BBP30, BBP31, BBP33, BBP35, BBP37	Fig. 18c	B30EP-171-593-YL	Yellow	1.060 (26.9)	0.490 (12.5)	0.750 (19.1)	1.375 (34.9)	1	500	B30-R6000
i3300, i5300, S3000, S3100, BBP30, BBP31, BBP33, BBP35, BBP37	Fig. 18c	B30EP-172-593-YL	Yellow	1.770 (45.0)	0.590 (15.0)	0.850 (21.6)	2.500 (63.5)	1	450	B30-R6000
i3300, i5300, S3000, S3100, BBP30, BBP31, BBP33, BBP35, BBP37	Fig. 18c	B30EP-175-593-YL	Yellow	3.000 (76.2)	0.750 (19.1)	1.000 (25.4)	3.250 (82.6)	1	375	B30-R6000
i3300, i5300, S3000, S3100, BBP30, BBP31, BBP33, BBP35, BBP37	Fig. 18c	B30EP-173-593-YL	Yellow	2.000 (50.8)	1.000 (25.4)	1.250 (31.8)	2.500 (63.5)	1	300	B30-R6000
i3300, i5300, S3000, S3100, BBP30, BBP31, BBP33, BBP35, BBP37	Fig. 18c	B30EP-174-593-YL	Yellow	4.000 (101.6)	1.000 (25.4)	1.250 (31.8)	4.250 (108.0)	1	300	B30-R6000
i3300, i5300, S3000, S3100, BBP30, BBP31, BBP33, BBP35, BBP37	Fig. 18c	B30EP-176-593-YL	Yellow	3.000 (76.2)	1.000 (25.4)	1.250 (31.8)	3.250 (82.6)	1	300	B30-R6000
i3300, i5300, S3000, S3100, BBP30, BBP31, BBP33, BBP35, BBP37	Fig. 18c	B30EP-177-593-YL	Yellow	3.000 (76.2)	2.500 (63.5)	2.750 (69.9)	3.250 (82.6)	1	125	B30-R6000
i3300, i5300, S3000, S3100, BBP30, BBP31, BBP33, BBP35, BBP37	Fig. 18c	B30EP-171-593-BK	Black	1.060 (26.9)	0.490 (12.5)	0.750 (19.1)	1.375 (34.9)	1	500	B30-R4400-WT
i3300, i5300, S3000, S3100, BBP30, BBP31, BBP33, BBP35, BBP37	Fig. 18c	B30EP-172-593-BK	Black	1.770 (45.0)	0.590 (15.0)	0.850 (21.6)	2.500 (63.5)	1	450	B30-R4400-WT
i3300, i5300, S3000, S3100, BBP30, BBP31, BBP33, BBP35, BBP37	Fig. 18c	B30EP-175-593-BK	Black	3.000 (76.2)	0.750 (19.1)	1.000 (25.4)	3.250 (82.6)	1	375	B30-R4400-WT
i3300, i5300, S3000, S3100, BBP30, BBP31, BBP33, BBP35, BBP37	Fig. 18c	B30EP-173-593-BK	Black	2.000 (50.8)	1.000 (25.4)	1.250 (31.8)	2.500 (63.5)	1	300	B30-R4400-WT
i3300, i5300, S3000, S3100, BBP30, BBP31, BBP33, BBP35, BBP37	Fig. 18c	B30EP-174-593-BK	Black	4.000 (101.6)	1.000 (25.4)	1.250 (31.8)	4.250 (108.0)	1	300	B30-R4400-WT
i3300, i5300, S3000, S3100, BBP30, BBP31, BBP33, BBP35, BBP37	Fig. 18c	B30EP-176-593-BK	Black	3.000 (76.2)	1.000 (25.4)	1.250 (31.8)	3.250 (82.6)	1	300	B30-R4400-WT
i3300, i5300, S3000, S3100, BBP30, BBP31, BBP33, BBP35, BBP37	Fig. 18c	B30EP-177-593-BK	Black	3.000 (76.2)	2.500 (63.5)	2.750 (69.9)	3.250 (82.6)	1	125	B30-R4400-WT
i3300, i5300, S3000, S3100, BBP30, BBP31, BBP33, BBP35, BBP37	Fig. 18c	B30EP-171-593-GN	Green	1.060 (26.9)	0.490 (12.5)	0.750 (19.1)	1.375 (34.9)	1	500	B30-R4400-WT
i3300, i5300, S3000, S3100, BBP30, BBP31, BBP33, BBP35, BBP37	Fig. 18c	B30EP-172-593-GN	Green	1.770 (45.0)	0.590 (15.0)	0.850 (21.6)	2.500 (63.5)	1	450	B30-R4400-WT
i3300, i5300, S3000, S3100, BBP30, BBP31, BBP33, BBP35, BBP37	Fig. 18c	B30EP-175-593-GN	Green	3.000 (76.2)	0.750 (19.1)	1.000 (25.4)	3.250 (82.6)	1	375	B30-R4400-WT
i3300, i5300, S3000, S3100, BBP30, BBP31, BBP33, BBP35, BBP37	Fig. 18c	B30EP-173-593-GN	Green	2.000 (50.8)	1.000 (25.4)	1.250 (31.8)	2.500 (63.5)	1	300	B30-R4400-WT
i3300, i5300, S3000, S3100, BBP30, BBP31, BBP33, BBP35, BBP37	Fig. 18c	B30EP-174-593-GN	Green	4.000 (101.6)	1.000 (25.4)	1.250 (31.8)	4.250 (108.0)	1	300	B30-R4400-WT
i3300, i5300, S3000, S3100, BBP30, BBP31, BBP33, BBP35, BBP37	Fig. 18c	B30EP-176-593-GN	Green	3.000 (76.2)	1.000 (25.4)	1.250 (31.8)	3.250 (82.6)	1	300	B30-R4400-WT
i3300, i5300, S3000, S3100, BBP30, BBP31, BBP33, BBP35, BBP37	Fig. 18c	B30EP-177-593-GN	Green	3.000 (76.2)	2.500 (63.5)	2.750 (69.9)	3.250 (82.6)	1	125	B30-R4400-WT
i3300, i5300, S3000, S3100, BBP30, BBP31, BBP33, BBP35, BBP37	Fig. 18c	B30EP-171-593-RD	Red	1.060 (26.9)	0.490 (12.5)	0.750 (19.1)	1.375 (34.9)	1	500	B30-R4400-WT
i3300, i5300, S3000, S3100, BBP30, BBP31, BBP33, BBP35, BBP37	Fig. 18c	B30EP-172-593-RD	Red	1.770 (45.0)	0.590 (15.0)	0.850 (21.6)	2.500 (63.5)	1	450	B30-R4400-WT
i3300, i5300, S3000, S3100, BBP30, BBP31, BBP33, BBP35, BBP37	Fig. 18c	B30EP-173-593-RD	Red	2.000 (50.8)	1.000 (25.4)	1.250 (31.8)	2.500 (63.5)	1	300	B30-R4400-WT
i3300, i5300, S3000, S3100, BBP30, BBP31, BBP33, BBP35, BBP37	Fig. 18c	B30EP-174-593-RD	Red	4.000 (101.6)	1.000 (25.4)	1.250 (31.8)	4.250 (108.0)	1	300	B30-R4400-WT
i3300, i5300, S3000, S3100, BBP30, BBP31, BBP33, BBP35, BBP37	Fig. 18c	B30EP-171-593-SL	Silver	1.060 (26.9)	0.490 (12.5)	0.750 (19.1)	1.375 (34.9)	1	500	B30-R6000
i3300, i5300, S3000, S3100, BBP30, BBP31, BBP33, BBP35, BBP37	Fig. 18c	B30EP-172-593-SL	Silver	1.770 (45.0)	0.590 (15.0)	0.850 (21.6)	2.500 (63.5)	1	450	B30-R6000
i3300, i5300, S3000, S3100, BBP30, BBP31, BBP33, BBP35, BBP37	Fig. 18c	B30EP-173-593-SL	Silver	2.000 (50.8)	1.000 (25.4)	1.250 (31.8)	2.500 (63.5)	1	300	B30-R6000
i3300, i5300, S3000, S3100, BBP30, BBP31, BBP33, BBP35, BBP37	Fig. 18c	B30EP-174-593-SL	Silver	4.000 (101.6)	1.000 (25.4)	1.250 (31.8)	4.250 (108.0)	1	300	B30-R6000

Panel Rating Plate Labels (B-486B, B-434A, B-8591, B-483A, B-8117)

- Variety of UL rated materials in larger sizes for labeling panels and enclosures
- High or Aggressive adhesive on all materials for rugged durability on smooth or rough panel surfaces
- Consult technical data sheet for complete performance, texting and ribbon use related to UL / CSA compliance

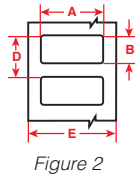

For Use with Printers:	Diagram	Catalog #	Color	Label width A inch (mm)	Label height B inch (mm)	Horiz. repeat C inch (mm)	Vert. repeat D inch (mm)	Web width E inch (mm)	Labels per row	Labels per roll	Rec. ribbon
Ultra-high adhesion matte light gray metallized polyester for highly textured or powder-coated surfaces (B-486B)											
i3300, i5300, BBP33	Fig. 2	B33-18-486	Matte Lt. Gray	3,000 (76.2)	1,000 (25.4)	-	1.125 (28.6)	3,200 (81.3)	1	1300	B30-R4300
i3300, i5300, BBP33	Fig. 2	B33-19-486	Matte Lt. Gray	3,000 (76.2)	2,000 (50.8)	-	2.125 (54.0)	3,200 (81.3)	1	500	B30-R4300
i3300, i5300, BBP33	Fig. 2	B33-55-486	Matte Lt. Gray	4,000 (101.6)	2,000 (50.8)	-	2.125 (54.0)	4,200 (106.7)	1	500	B30-R4300
i3300, i5300, BBP33	Fig. 2	B33-76-486	Matte Lt. Gray	4,000 (101.6)	3,000 (76.2)	-	3.125 (79.4)	4,200 (106.7)	1	500	B30-R4300
i3300, i5300, BBP33	Fig. 2	B33-161-486	Matte Lt. Gray	4,000 (101.6)	4,000 (101.6)	-	4.125 (104.8)	4,200 (106.7)	1	250	B30-R4300
High-gloss silver metallized polyester with high adhesion for textured surfaces (B-434A)											
i3300, i5300, BBP33	Fig. 2	B33-18-434	Gloss Silver	3,000 (76.2)	1,000 (25.4)	-	1.125 (28.6)	3,200 (81.3)	1	1500	B30-R6000
i3300, i5300, BBP33	Fig. 2	B33-19-434	Gloss Silver	3,000 (76.2)	2,000 (50.8)	-	2.125 (54.0)	3,200 (81.3)	1	500	B30-R6000
i3300, i5300, BBP33	Fig. 2	B33-55-434	Gloss Silver	4,000 (101.6)	2,000 (50.8)	-	2.125 (54.0)	4,200 (106.7)	1	750	B30-R6000
i3300, i5300, BBP33	Fig. 2	B33-161-434	Gloss Silver	4,000 (101.6)	4,000 (101.6)	-	4.125 (104.7)	4,200 (106.7)	1	350	B30-R6000
All-weather outdoor-grade polyester with metal appearance but non-metal construction (B-8591)											
i3300, i5300, BBP33	Fig. 2	B33-18-8591-SL	Silver	3,000 (76.2)	1,000 (25.4)	-	1.125 (29.2)	3,200 (81.3)	1	1500	B30-R6600
i3300, i5300, BBP33	Fig. 2	B33-19-8591-SL	Silver	3,000 (76.2)	2,000 (50.8)	-	2.125 (54.0)	3,200 (81.3)	1	750	B30-R6600
i3300, i5300, BBP33	Fig. 2	B33-55-8591-SL	Silver	4,000 (101.6)	2,000 (50.8)	-	2.125 (54.0)	4,200 (106.7)	1	750	B30-R6600
i3300, i5300, BBP33	Fig. 2	B33-76-8591-SL	Silver	4,000 (101.6)	3,000 (76.2)	-	3.125 (79.3)	4,200 (106.7)	1	400	B30-R6600
i3300, i5300, BBP33	Fig. 2	B33-161-8591-SL	Silver	4,000 (101.6)	4,000 (101.6)	-	4.125 (104.8)	4,200 (106.7)	1	400	B30-R6600
i3300, i5300, BBP33	Fig. 2	B33-25-8591-SL	Silver	4,000 (101.6)	6,000 (152.4)	-	6.125 (155.6)	4,200 (106.7)	1	250	B30-R6600
Ultra-high adhesion high-gloss white polyester with aggressive adhesive for flat but highly textured surfaces (B-483A)											
i3300, i5300, BBP33	Fig. 2	B33-18-483	Gloss White	3,000 (76.2)	1,000 (25.4)	-	1.125 (28.6)	3,200 (81.3)	1	1500	B30-R6000
i3300, i5300, BBP33	Fig. 2	B33-19-483	Gloss White	3,000 (76.2)	2,000 (50.8)	-	2.125 (54.0)	3,200 (81.3)	1	500	B30-R6000
i3300, i5300, BBP33	Fig. 2	B33-55-483	Gloss White	4,000 (101.6)	2,000 (50.8)	-	2.125 (54.0)	4,200 (106.7)	1	750	B30-R6000
i3300, i5300, BBP33	Fig. 2	B33-76-483	Gloss White	4,000 (101.6)	3,000 (76.2)	-	3.125 (79.3)	4,200 (106.7)	1	500	B30-R6000
Matte black polyester with permanent adhesive for flat, smooth or lightly textured surfaces (B-8117)											
i3300, i5300, BBP33	Fig. 2	B33-18-8117	Matte Black	3,000 (76.2)	1,000 (25.4)	-	1.125 (28.5)	3,350 (85.1)	1	1000	B30-R6800-WT
i3300, i5300, BBP33	Fig. 2	B33-19-8117	Matte Black	3,000 (76.2)	2,000 (50.8)	-	2.125 (54.0)	3,200 (81.3)	1	500	B30-R6800-WT
i3300, i5300, BBP33	Fig. 2	B33-55-8117	Matte Black	4,000 (101.6)	2,000 (50.8)	-	2.125 (54.0)	4,200 (106.7)	1	500	B30-R6800-WT
i3300, i5300, BBP33	Fig. 2	B33-76-8117	Matte Black	4,000 (101.6)	3,000 (76.2)	-	3.125 (79.3)	4,200 (106.7)	1	330	B30-R6800-WT

UL-Rated Arc Flash Sign Headers (B-483A pre-print headers)

- Pre-printed headers with user-printable zone F below
- Create your custom layout or use Arc Flash templates in Brady WorkStation software Arc Flash App
- Glossy ultra-high adhesion material adheres to smooth or highly textured, metal and non-metal surfaces
- UL rated material - consult technical data sheet for complete performance and testing details

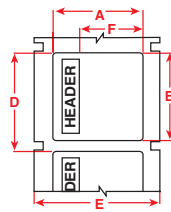

For Use with Printers:	Diagram	Catalog #	Header	Label width A inch (mm)	Label height B inch (mm)	Vert. repeat D inch (mm)	Web width E inch (mm)	Print Height F inch (mm)	Labels per row	Labels per roll	Rec. ribbon
i3300, i5300, BBP33	Fig. 70a	B33-25-483-ANSIWA		4,000 (101.6)	6,000 (152.4)	6,500 (165.1)	4,200 (106.7)	2,875 (73.0)	1	250	B30-R6000
i3300, i5300, BBP33	Fig. 70a	B33-161-483-ANSIWA		4,000 (101.6)	4,000 (101.6)	4,500 (114.3)	4,200 (106.7)	2,875 (73.0)	1	370	B30-R6000
i3300, i5300, BBP33	Fig. 70a	B33-184-483-ANSIWA		3,000 (76.2)	3,000 (76.2)	3,500 (88.9)	3,200 (81.3)	1,875 (47.6)	1	500	B30-R6000
i3300, i5300, BBP33	Fig. 70a	B33-25-483-ANSIDA		4,000 (101.6)	6,000 (152.4)	6,500 (165.1)	4,200 (106.7)	2,875 (73.0)	1	250	B30-R6000
i3300, i5300, BBP33	Fig. 70a	B33-161-483-ANSIDA		4,000 (101.6)	4,000 (101.6)	4,500 (114.3)	4,200 (106.7)	2,875 (73.0)	1	370	B30-R6000
i3300, i5300, BBP33	Fig. 70a	B33-184-483-ANSIDA		3,000 (76.2)	3,000 (76.2)	3,500 (88.9)	3,200 (81.3)	1,875 (47.6)	1	500	B30-R6000

Inside-Panel Component Labels (B-499, B-483A, B-484A, B-593)

- Various sizes in several durable material types
- Ideal for labeling backer board, relays, PLCs, switches, breakers, power supplies and other components inside panels
- All recommended materials are flexible or have extra high-tack adhesives for adhesion to wide variety of surfaces and components

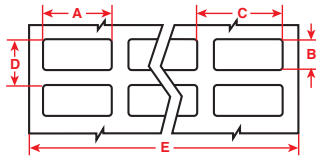

Figure 1

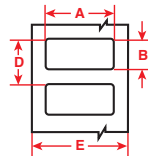

Figure 2

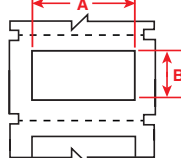

Figure 18c



For Use with Printers:	Diagram	Catalog #	Color	Label width A inch (mm)	Label height B inch (mm)	Horiz. repeat C inch (mm)	Vert. repeat D inch (mm)	Web width E inch (mm)	Labels per row	Labels per roll	Rec. ribbon
Nylon cloth with permanent adhesive for angled, curved and rough surfaces (B-499)											
i3300, i5300, BBP33	Fig. 1	B33-68-499	White	0.500 (12.7)	0.750 (19.1)	0.600 (15.2)	0.875 (22.2)	2.500 (63.5)	4	1500	B30-R6200
i3300, i5300, BBP33	Fig. 1	B33-87-499	White	0.500 (12.7)	1.437 (36.4)	0.600 (15.2)	1.562 (39.7)	3.700 (94.0)	6	2500	B30-R6000
i3300, i5300, BBP33	Fig. 1	B33-1-499	White	0.750 (19.1)	0.250 (6.4)	0.800 (20.3)	0.350 (8.9)	3.350 (85.1)	4	10000	B30-R6000
i3300, i5300, BBP33	Fig. 1	B33-5-499	White	1.000 (25.4)	0.500 (12.7)	1.075 (27.3)	0.600 (15.2)	3.350 (85.1)	3	5000	B30-R6000
i3300, i5300, BBP33	Fig. 1	B33-88-499	White	1.000 (25.4)	0.750 (19.1)	1.100 (27.9)	0.875 (22.2)	2.300 (58.4)	2	2500	B30-R6000
i3300, i5300, BBP33	Fig. 1	B33-89-499	White	1.000 (25.4)	1.440 (36.5)	1.100 (27.9)	1.562 (39.7)	3.400 (86.4)	3	2300	B30-R6000
i3300, i5300, BBP33	Fig. 2	B33-136-499	White	1.500 (38.1)	0.750 (19.1)	-	0.875 (22.2)	1.770 (45.0)	1	1500	B30-R6000
i3300, i5300, BBP33	Fig. 2	B33-151-499	White	2.000 (50.8)	0.250 (6.4)	-	0.350 (8.9)	2.200 (55.9)	1	1500	B30-R4300
i3300, i5300, BBP33	Fig. 2	B33-137-499	White	2.000 (50.8)	1.000 (25.4)	-	1.125 (28.6)	2.200 (55.9)	1	1100	B30-R6000
Ultra-high adhesion gloss polyester with aggressive adhesive for flat but highly textured surfaces (B-483A)											
i3300, i5300, BBP33	Fig. 1	B33-12-483	Gloss White	0.500 (12.7)	0.437 (11.0)	0.662 (16.8)	0.537 (13.6)	3.350 (85.1)	5	10000	B30-R6000
i3300, i5300, BBP33	Fig. 1	B33-5-483	Gloss White	1.000 (25.4)	0.500 (12.7)	1.075 (27.3)	0.600 (15.2)	3.350 (85.1)	3	5000	B30-R6000
i3300, i5300, BBP33	Fig. 1	B33-37-483	Gloss White	1.500 (38.1)	0.500 (12.7)	1.650 (41.9)	0.600 (15.2)	3.350 (85.1)	2	5000	B30-R6000
i3300, i5300, BBP33	Fig. 1	B33-6-483	Gloss White	1.500 (38.1)	0.750 (19.1)	1.650 (41.9)	0.875 (22.2)	3.350 (85.1)	2	3300	B30-R6000
i3300, i5300, BBP33	Fig. 2	B33-53-483	Gloss White	2.000 (50.8)	0.500 (12.7)	-	0.600 (15.2)	2.200 (55.9)	1	2500	B30-R6000
i3300, i5300, BBP33	Fig. 2	B33-17-483	Gloss White	2.000 (50.8)	1.000 (25.4)	-	1.125 (28.6)	2.200 (55.9)	1	1500	B30-R6000
High adhesion flexible polyester for conforming to textured and angular or uneven surfaces (B-484A)											
i3300, i5300, BBP33	Fig. 2	B33-125-484	Gloss White	0.900 (22.9)	0.500 (12.7)	-	0.600 (15.2)	1.100 (27.9)	1	1500	B30-R6000
i3300, i5300, BBP33	Fig. 1	B33-5-484	Gloss White	1.000 (25.4)	0.500 (12.7)	1.075 (27.3)	0.600 (15.2)	3.350 (85.1)	3	5000	B30-R6000
i3300, i5300, BBP33	Fig. 2	B33-136-484	Gloss White	1.500 (38.1)	0.750 (19.1)	-	0.875 (22.2)	1.700 (43.2)	1	1500	B30-R6000
i3300, i5300, BBP33	Fig. 2	B33-17-484	Gloss White	2.000 (50.8)	1.000 (25.4)	-	1.125 (28.6)	2.200 (55.9)	1	1500	B30-R6000
Raised profile polyester, thick, with extra-strength adhesive for textured surfaces (B-593)											
i3300, i5300, S3000, S3100, BBP30, BBP31, BBP33, BBP35, BBP37	Fig. 18c	B30EP-171-593-WT	White	1.060 (26.9)	0.490 (12.5)	-	0.750 (19.1)	1.375 (34.9)	1	500	B30-R6000
i3300, i5300, S3000, S3100, BBP30, BBP31, BBP33, BBP35, BBP37	Fig. 18c	B30EP-172-593-WT	White	1.770 (45.0)	0.590 (15.0)	-	0.850 (21.6)	2.500 (63.5)	1	450	B30-R6000
i3300, i5300, S3000, S3100, BBP30, BBP31, BBP33, BBP35, BBP37	Fig. 18c	B30EP-173-593-WT	White	2.000 (50.8)	1.000 (25.4)	-	1.250 (31.8)	2.500 (63.5)	1	300	B30-R6000

Adhesive Strips for Terminal Blocks and Patch Panels (B-498, B-422)

- Specially designed narrow-width continuous label for alignment on terminal blocks and patch panels
- Available in permanent or repositionable adhesive, UL-rated

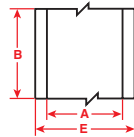

Figure 3a



For Use with Printers:	Diagram	Catalog #	Color	Label width A inch (mm)	Roll Length B feet (m)	Web width E inch (mm)	Labels per roll	Rec. ribbon
Vinyl Cloth – Aggressive but repositionable adhesive (B-498)								
i3300, i5300, BBP33	Fig. 3a	B33C-312-498	Matte White	0.312 (7.9)	85 (25.9)	1.000 (25.4)	1 roll (cont.)	B30-R6200
i3300, i5300, BBP33	Fig. 3a	B33C-375-498	Matte White	0.375 (9.5)	85 (25.9)	1.000 (25.4)	1 roll (cont.)	B30-R6200
Polyester – High gloss with permanent adhesive for smooth or textured surfaces (B-422)								
i3300, i5300, BBP33	Fig. 3a	B33C-312-422	Gloss White	0.312 (7.9)	85 (25.9)	1.000 (25.4)	1 roll (cont.)	B30-R6000
i3300, i5300, BBP33	Fig. 3a	B33C-375-422	Gloss White	0.375 (9.5)	85 (25.9)	1.000 (25.4)	1 roll (cont.)	B30-R6000

Self-Laminating Wire and Cable Wraps (B-427, B-417)

- Features white printable area with clear "tail" that wraps around cable or wire to protect text
- Superior resistance to abrasion, handling, solvents, water, oil and dirt
- Adhesive is designed specifically for tightly curved surfaces
- B-417 material has advanced performance to adhere in high humidity conditions, on smaller diameter wires and on challenging wire jacket materials including Teflon, Silicone, Braided and traditional PVC
- The "all-white" parts are used for flagging cables

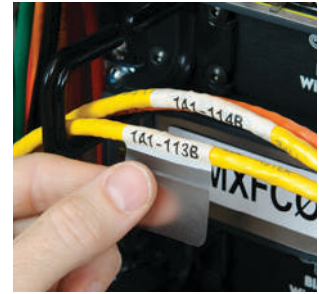
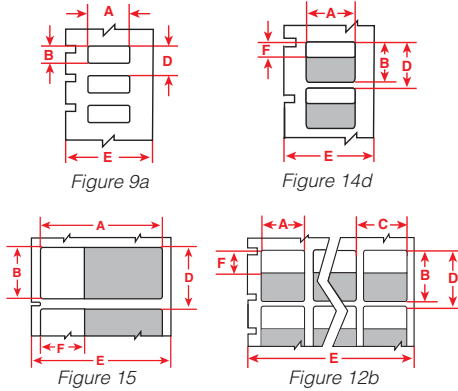

For Use with Printers:	Diagram	Catalog #	Color	Label width A inch (mm)	Label height B inch (mm)	Horiz. repeat C inch (mm)	Vert. repeat D inch (mm)	Web width E inch (mm)	"Print Area Height F inch (mm)"	Labels per row	Labels per roll	Rec. ribbon
Self-laminating vinyl (B-427)												
i3300, i5300, BBP33	Fig. 12b	B33-80-427	White/Clear	0.500 (12.7)	0.750 (19.1)	0.600 (15.2)	0.950 (24.1)	2.500 (63.5)	0.375 (9.5)	4	2500	B30-R4300
i3300, i5300, BBP33	Fig. 12b	B33-113-427	White/Clear	0.500 (12.7)	1.000 (25.4)	0.600 (15.2)	0.950 (24.1)	2.500 (63.5)	0.375 (9.5)	4	2500	B30-R4300
i3300, i5300, BBP33	Fig. 12b	B33-114-427	White/Clear	0.500 (12.7)	1.250 (31.8)	0.600 (15.2)	1.375 (34.9)	2.500 (63.5)	0.500 (12.7)	4	4000	B30-R4300
i3300, i5300, BBP33	Fig. 12b	B33-8-427	White/Clear	0.500 (12.7)	1.437 (36.5)	0.662 (16.8)	1.625 (41.3)	3.350 (85.1)	0.500 (12.7)	5	5000	B30-R4300
i3300, i5300, BBP33	Fig. 12b	B33-56-427	White/Clear	0.750 (19.1)	0.937 (23.8)	0.800 (20.3)	1.125 (28.6)	3.350 (85.1)	0.375 (9.5)	4	5000	B30-R4300
i3300, i5300, BBP33	Fig. 12b	B33-73-427	White/Clear	0.750 (19.1)	1.750 (44.6)	0.800 (20.3)	1.875 (47.6)	3.350 (85.1)	0.500 (12.7)	4	3500	B30-R4300
i3300, i5300, BBP33	Fig. 12b	B33-74-427	White/Clear	0.800 (20.3)	1.437 (36.5)	0.800 (20.3)	1.625 (41.3)	3.400 (86.4)	0.500 (12.7)	4	4000	B30-R4300
i3300, i5300, BBP33	Fig. 12b	B33-115-427	White/Clear	1.000 (25.4)	0.750 (19.1)	1.100 (27.9)	0.875 (22.2)	2.300 (58.4)	0.375 (9.5)	2	2500	B30-R4300
i3300, i5300, BBP33	Fig. 12b	B33-116-427	White/Clear	1.000 (25.4)	1.000 (25.4)	1.100 (27.9)	1.125 (28.6)	2.300 (58.4)	0.375 (9.5)	2	2500	B30-R4300
i3300, i5300, BBP33	Fig. 12b	B33-117-427	White/Clear	1.000 (25.4)	1.250 (31.8)	1.100 (27.9)	1.375 (34.9)	2.300 (58.4)	0.500 (12.7)	2	2000	B30-R4300
i3300, i5300, BBP33	Fig. 12b	B33-9-427	White/Clear	1.000 (25.4)	1.437 (36.5)	1.075 (27.3)	1.625 (41.3)	3.350 (85.1)	0.500 (12.7)	3	2500	B30-R4300
i3300, i5300, BBP33	Fig. 12b	B33-75-427	White/Clear	1.000 (25.4)	2.250 (57.2)	1.100 (27.9)	2.375 (60.3)	2.300 (58.4)	0.750 (19.1)	2	1400	B30-R4300
i3300, i5300, BBP33	Fig. 12b	B33-10-427	White/Clear	1.000 (25.4)	3.750 (95.3)	1.075 (27.3)	4.000 (101.6)	3.350 (85.1)	1.000 (25.4)	3	1200	B30-R4300
i3300, i5300, BBP33	Fig. 12b	B33-81-427	White/Clear	1.000 (25.4)	6.000 (152.4)	1.100 (27.9)	6.187 (157.1)	2.300 (58.4)	1.500 (38.1)	2	500	B30-R4300
i3300, i5300, BBP33	Fig. 14d	B33-118-427	White/Clear	1.500 (38.1)	1.000 (25.4)	-	1.125 (28.6)	1.700 (43.2)	0.375 (9.5)	1	1250	B30-R4300
i3300, i5300, BBP33	Fig. 14d	B33-119-427	White/Clear	1.500 (38.1)	1.500 (38.1)	-	1.625 (41.3)	1.700 (43.2)	0.500 (12.7)	1	1000	B30-R4300
i3300, i5300, BBP33	Fig. 14d	B33-272-427	White/Clear	1.500 (38.1)	2.250 (57.2)	-	2.500 (63.5)	1.700 (43.2)	0.750 (19.1)	1	700	B30-R4300
i3300, i5300, BBP33	Fig. 14d	B33-120-427	White/Clear	1.750 (44.5)	1.000 (25.4)	-	1.125 (28.6)	1.950 (49.5)	0.375 (9.5)	1	1250	B30-R4300
i3300, i5300, BBP33	Fig. 14d	B33-121-427	White/Clear	1.750 (44.5)	1.500 (38.1)	-	1.750 (44.6)	1.950 (49.5)	0.500 (12.7)	1	1000	B30-R4300
i3300, i5300, BBP33	Fig. 14d	B33-273-427	White/Clear	1.750 (44.5)	2.250 (57.2)	-	2.500 (63.5)	1.950 (49.5)	0.750 (19.1)	1	500	B30-R4300
i3300, i5300, BBP33	Fig. 14d	B33-27-427	White/Clear	2.000 (50.8)	3.750 (95.3)	-	4.000 (101.6)	2.200 (55.9)	1.000 (25.4)	1	400	B30-R4300
i3300, i5300, BBP33	Fig. 14d	B33-82-427	White/Clear	2.000 (50.8)	6.000 (152.4)	-	6.187 (157.1)	2.200 (55.9)	1.500 (38.1)	1	200	B30-R4300
i3300, i5300, BBP33	Fig. 14d	B33-26-427	White/Clear	2.500 (63.5)	2.250 (57.2)	-	2.438 (61.9)	2.700 (68.8)	0.750 (19.1)	1	500	B30-R4300
i3300, i5300, BBP33	Fig. 15	B33-131-427	White/Clear	2.625 (66.7)	1.000 (25.4)	-	1.125 (28.6)	2.825 (71.8)	1.000 (25.4)	1	1500	B30-R4300
i3300, i5300, BBP33	Fig. 9a	B33-137-427AW	White	2.000 (50.8)	1.000 (25.4)	-	1.125 (28.6)	2.200 (55.9)	-	1	1500	B30-R4300
i3300, i5300, BBP33	Fig. 9a	B33-135-427AW	White	1.500 (38.1)	0.750 (19.1)	-	0.875 (22.2)	1.700 (43.2)	-	1	1500	B30-R4300
High Adhesion self-laminating vinyl (B-417)												
i3300, i5300, BBP33	Fig. 12b	B33-80-417	White/Clear	0.500 (12.7)	0.750 (19.1)	0.600 (15.2)	0.950 (24.1)	2.500 (63.5)	0.375 (9.5)	4	2500	B30-R4300
i3300, i5300, BBP33	Fig. 12b	B33-114-417	White/Clear	0.500 (12.7)	1.250 (31.8)	0.600 (15.2)	1.375 (34.9)	2.500 (63.5)	0.500 (12.7)	4	4000	B30-R4300
i3300, i5300, BBP33	Fig. 12b	B33-8-417	White/Clear	0.500 (12.7)	1.437 (36.5)	0.662 (16.8)	1.625 (41.3)	3.350 (85.1)	0.500 (12.7)	5	5000	B30-R4300
i3300, i5300, BBP33	Fig. 12b	B33-56-417	White/Clear	0.750 (19.1)	0.937 (23.8)	0.800 (20.3)	1.125 (28.6)	3.350 (85.1)	0.375 (9.5)	4	5000	B30-R4300
i3300, i5300, BBP33	Fig. 12b	B33-73-417	White/Clear	0.750 (19.1)	1.750 (44.6)	0.800 (20.3)	1.875 (47.6)	3.350 (85.1)	0.500 (12.7)	4	3500	B30-R4300
i3300, i5300, BBP33	Fig. 12b	B33-116-417	White/Clear	1.000 (25.4)	1.000 (25.4)	1.100 (27.9)	1.125 (28.6)	2.300 (58.4)	0.375 (9.5)	2	2500	B30-R4300
i3300, i5300, BBP33	Fig. 12b	B33-117-417	White/Clear	1.000 (25.4)	1.250 (31.8)	1.100 (27.9)	1.375 (34.9)	2.300 (58.4)	0.500 (12.7)	2	2000	B30-R4300
i3300, i5300, BBP33	Fig. 12b	B33-9-417	White/Clear	1.000 (25.4)	1.437 (36.5)	1.075 (27.3)	1.625 (41.3)	3.350 (85.1)	0.500 (12.7)	3	2500	B30-R4300
i3300, i5300, BBP33	Fig. 12b	B33-75-417	White/Clear	1.000 (25.4)	2.250 (57.2)	1.100 (27.9)	2.375 (60.3)	2.300 (58.4)	0.750 (19.1)	2	1400	B30-R4300
i3300, i5300, BBP33	Fig. 12b	B33-10-417	White/Clear	1.000 (25.4)	3.750 (95.3)	1.075 (27.3)	4.000 (101.6)	3.350 (85.1)	1.000 (25.4)	3	1200	B30-R4300
i3300, i5300, BBP33	Fig. 12b	B33-81-417	White/Clear	1.000 (25.4)	6.000 (152.4)	1.100 (27.9)	6.187 (157.1)	2.300 (58.4)	1.500 (38.1)	2	500	B30-R4300
i3300, i5300, BBP33	Fig. 14d	B33-119-417	White/Clear	1.500 (38.1)	1.500 (38.1)	-	1.625 (41.3)	1.700 (43.2)	0.500 (12.7)	1	1000	B30-R4300
i3300, i5300, BBP33	Fig. 14d	B33-27-417	White/Clear	2.000 (50.8)	3.750 (95.3)	-	4.000 (101.6)	2.200 (55.9)	1.000 (25.4)	1	400	B30-R4300
i3300, i5300, BBP33	Fig. 14d	B33-26-417	White/Clear	2.500 (63.5)	2.250 (57.2)	-	2.438 (61.9)	2.700 (68.8)	0.750 (19.1)	1	500	B30-R4300

Rotating Self-Laminating Wire and Cable Wraps (B-427)

- Allows rotation of an over-laminated label on the cable to prevent cable damage and allow viewing of entire label from any angle
- Increases print area due to improved viewing ability
- Final installed label has over-laminated text and spins freely on the cable
- Use B dimension when considering label length for "cable diameter fit"

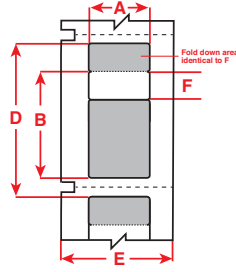

Figure 87

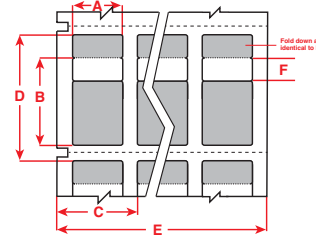
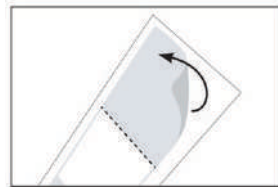
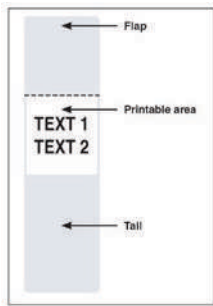

Figure 87b



For Use with Printers:	Diagram	Catalog #	Color	Label width A inch (mm)	Label height B inch (mm)	Horiz. repeat C inch (mm)	Vert. repeat D inch (mm)	Web width E inch (mm)	Print Area Height F inch (mm)	Labels per row	Labels per roll	Rec. ribbon
i3300, i5300, BBP33	Fig. 87b	B33RO-292-427	White/Clear	0.500 (12.7)	1.750 (44.4)	0.700 (17.7)	2.575 (65.4)	2.100 (53.3)	0.700 (17.7)	3	1500	B30-R4300
i3300, i5300, BBP33	Fig. 87b	B33RO-293-427	White/Clear	0.500 (12.7)	2.750 (69.9)	0.700 (17.7)	4.063 (103.2)	2.100 (53.3)	1.100 (27.9)	3	900	B30-R4300
i3300, i5300, BBP33	Fig. 87b	B33RO-294-427	White/Clear	1.000 (25.4)	1.750 (44.4)	1.250 (31.8)	2.575 (65.4)	2.450 (62.2)	0.700 (17.7)	2	1000	B30-R4300
i3300, i5300, BBP33	Fig. 87b	B33RO-295-427	White/Clear	1.000 (25.4)	2.750 (69.9)	1.250 (31.8)	4.063 (103.2)	2.450 (62.2)	1.100 (27.9)	2	700	B30-R4300
i3300, i5300, BBP33	Fig. 87b	B33RO-296-427	White/Clear	1.000 (25.4)	3.125 (79.3)	1.250 (31.8)	4.563 (115.9)	2.450 (62.2)	1.250 (31.8)	2	600	B30-R4300
i3300, i5300, BBP33	Fig. 87b	B33RO-297-427	White/Clear	1.000 (25.4)	1.200 (30.4)	1.250 (31.8)	1.825 (46.4)	2.450 (62.2)	0.500 (12.7)	2	600	B30-R4300
i3300, i5300, BBP33	Fig. 87	B33RO-299-427	White/Clear	2.000 (50.8)	3.125 (79.3)	-	4.563 (115.9)	2.200 (55.9)	1.250 (31.8)	1	250	B30-R4300

Rotating Self-Laminating Wrap Application:



1. Peel label partially from liner, after printing

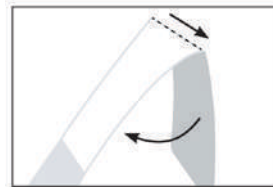

2. Fold flap behind printable area at perforated line



3. Wrap so printable area overlaps, continue wrapping tail around label

BradyGrip™ Print-on Hook Material featuring VELCRO® Brand Hook for cable/cord bundle Identification (B-414)

- Print your hook label, apply to VELCRO® Brand ONE-WRAP® roll and apply the complete solution to your cable or wire bundle
- Won't damage cables or wires the way nylon cable ties can
- A quick, repositionable and size-flexible identification solution for cable bundles that may need to be accessed and changed over time
- VELCRO® Brand ONE-WRAP® product not included with purchase

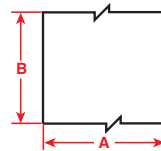

Figure 3b

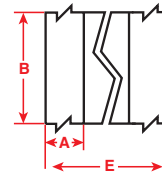

Figure 3c



For Use with Printers:	Diagram	Catalog #	Color	Label width A inch (mm)	Roll Length B feet (m)	Web width E inch (mm)	Quantity of Strips	Labels per roll	Rec. ribbon
i3300, i5300, BBP33	Fig. 3c	B33C-250-414	Gloss White	0.250 (6.4)	50 (15.2)	0.750 (19.1)	3	1 roll (cont.)	B30-R6000
i3300, i5300, BBP33	Fig. 3c	B33C-500-414	Gloss White	0.500 (12.7)	50 (15.2)	1.000 (25.4)	2	1 roll (cont.)	B30-R6000
i3300, i5300, BBP33	Fig. 3b	B33C-750-414	Gloss White	0.750 (19.1)	50 (15.2)	n/a	1	1 roll (cont.)	B30-R6000

Cloth Wire and Cable Wraps (B-498, B-499)

- Flexible materials conform very well to tightly curved surfaces
- B-498 has unique adhesive that provides excellent holding power to tightly curved surfaces and still allows for clean removal and multiple reapplications – an ideal choice for marking both ends of a wire that may need to be cut shorter before final termination
- Both multi-purpose materials are also excellent for labeling inside-of-panel components

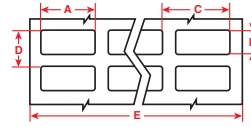

Figure 1

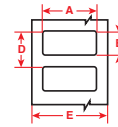

Figure 2



For Use with Printers:	Diagram	Catalog #	Color	Label width A inch (mm)	Label height B inch (mm)	Horiz. repeat C inch (mm)	Vert. repeat D inch (mm)	Web width E inch (mm)	Labels per row	Labels per roll	Rec. ribbon
Repositionable vinyl cloth wire wraps (B-498)											
i3300, i5300, BBP33	Fig. 1	B33-90-498	Matte White	0.250 (6.4)	1.437 (36.5)	0.350 (8.9)	1.562 (39.7)	2.200 (55.9)	6	2500	B30-R6200
i3300, i5300, BBP33	Fig. 1	B33-68-498	Matte White	0.500 (12.7)	0.750 (19.1)	0.600 (15.2)	0.875 (22.2)	2.500 (63.5)	4	5000	B30-R6200
i3300, i5300, BBP33	Fig. 1	B33-87-498	Matte White	0.500 (12.7)	1.437 (36.5)	0.600 (15.2)	1.562 (39.7)	3.700 (94.0)	6	2500	B30-R6200
i3300, i5300, BBP33	Fig. 1	B33-1-498	Matte White	0.750 (19.1)	0.250 (6.4)	0.800 (20.3)	0.350 (8.9)	3.350 (85.1)	4	5000	B30-R6200
i3300, i5300, BBP33	Fig. 2	B33-254-498	Matte White	0.750 (19.1)	0.750 (19.1)	-	0.850 (21.6)	1.000 (25.4)	1	1000	B30-R6200
i3300, i5300, BBP33	Fig. 1	B33-91-498	Matte White	0.750 (19.1)	0.937 (23.8)	0.850 (21.6)	1.062 (27.0)	3.500 (88.9)	4	2500	B30-R6200
i3300, i5300, BBP33	Fig. 1	B33-95-498	Matte White	0.800 (20.3)	1.437 (36.5)	0.900 (22.9)	1.562 (39.7)	2.800 (71.1)	3	2300	B30-R6200
i3300, i5300, BBP33	Fig. 1	B33-5-498	Matte White	1.000 (25.4)	0.500 (12.7)	1.075 (27.3)	0.600 (15.2)	3.350 (85.1)	3	5000	B30-R6200
i3300, i5300, BBP33	Fig. 1	B33-88-498	Matte White	1.000 (25.4)	0.750 (19.1)	1.100 (27.9)	0.875 (22.2)	2.300 (58.4)	2	2500	B30-R6200
i3300, i5300, BBP33	Fig. 1	B33-89-498	Matte White	1.000 (25.4)	1.437 (36.5)	1.100 (27.9)	1.562 (39.7)	3.400 (86.4)	3	2300	B30-R6200
i3300, i5300, BBP33	Fig. 1	B33-325-498	Matte White	1.000 (25.4)	2.500 (63.5)	1.150 (29.2)	2.625 (66.7)	2.350 (59.7)	2	700	B30-R6200
i3300, i5300, BBP33	Fig. 1	B33-326-498	Matte White	1.000 (25.4)	4.000 (101.6)	1.150 (29.2)	4.125 (104.8)	2.350 (59.7)	2	450	B30-R6200
i3300, i5300, BBP33	Fig. 1	B33-327-498	Matte White	1.500 (38.1)	4.000 (101.6)	1.650 (41.9)	4.125 (104.8)	3.350 (85.1)	2	450	B30-R6200
i3300, i5300, BBP33	Fig. 1	B33-328-498	Matte White	1.500 (38.1)	6.000 (152.4)	1.650 (41.9)	6.125 (155.6)	3.350 (85.1)	2	300	B30-R6200
Permanent adhesive nylon cloth wire wraps (B-499)											
i3300, i5300, BBP33	Fig. 1	B33-90-499	White	0.250 (6.4)	1.437 (36.4)	0.350 (8.9)	1.562 (39.7)	2.200 (55.9)	6	2500	B30-R6000
i3300, i5300, BBP33	Fig. 1	B33-68-499	White	0.500 (12.7)	0.750 (19.1)	0.600 (15.2)	0.875 (22.2)	2.500 (63.5)	4	1500	B30-R6200
i3300, i5300, BBP33	Fig. 1	B33-87-499	White	0.500 (12.7)	1.437 (36.4)	0.600 (15.2)	1.562 (39.7)	3.700 (94.0)	6	2500	B30-R6000
i3300, i5300, BBP33	Fig. 1	B33-1-499	White	0.750 (19.1)	0.250 (6.4)	0.800 (20.3)	0.350 (8.9)	3.350 (85.1)	4	10000	B30-R6000
i3300, i5300, BBP33	Fig. 2	B33-254-499	White	0.750 (19.1)	0.750 (19.1)	-	0.850 (21.6)	1.000 (25.4)	1	1000	B30-R6000
i3300, i5300, BBP33	Fig. 1	B33-91-499	White	0.750 (19.1)	0.937 (23.7)	0.850 (21.6)	1.062 (27.0)	3.500 (88.9)	4	2500	B30-R6000
i3300, i5300, BBP33	Fig. 1	B33-5-499	White	1.000 (25.4)	0.500 (12.7)	1.075 (27.3)	0.600 (15.2)	3.350 (85.1)	3	5000	B30-R6000
i3300, i5300, BBP33	Fig. 1	B33-88-499	White	1.000 (25.4)	0.750 (19.1)	1.100 (27.9)	0.875 (22.2)	2.300 (58.4)	2	2500	B30-R6000
i3300, i5300, BBP33	Fig. 1	B33-89-499	White	1.000 (25.4)	1.440 (36.5)	1.100 (27.9)	1.562 (39.7)	3.400 (86.4)	3	2300	B30-R6000
i3300, i5300, BBP33	Fig. 1	B33-325-499	White	1.000 (25.4)	2.500 (63.5)	1.150 (29.2)	2.625 (66.7)	2.350 (59.7)	2	700	B30-R6000
i3300, i5300, BBP33	Fig. 1	B33-326-499	White	1.000 (25.4)	4.000 (101.6)	1.150 (29.2)	4.125 (104.8)	2.350 (59.7)	2	450	B30-R6000
i3300, i5300, BBP33	Fig. 1	B33-327-499	White	1.500 (38.1)	4.000 (101.6)	1.650 (41.9)	4.125 (104.8)	3.350 (85.1)	2	450	B30-R6000
i3300, i5300, BBP33	Fig. 1	B33-328-499	White	1.500 (38.1)	6.000 (152.4)	1.650 (41.9)	6.125 (155.6)	3.350 (85.1)	2	300	B30-R6000

High-Temp Self-Extinguishing Tedlar® Wire Wraps (B-437)

- Top-coated polyvinylfluoride label for wire and cable marking where high temperature and self-extinguishing features are required
- Heavy-duty performance with excellent resistance to water, oil and other fluids and meets MIL-M-87958 Standard
- Upper temp limit of up to 275°F – consult technical data sheet for full performance details

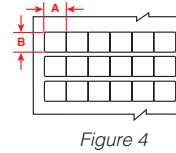
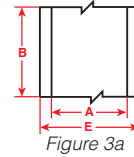
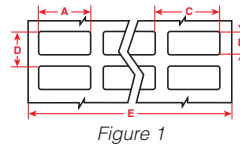

For Use with Printers:	Diagram	Catalog #	Color	Label width A inch (mm)	Label height B inch (mm)	Horiz. repeat C inch (mm)	Vert. repeat D inch (mm)	Web width E inch (mm)	Labels per row	Labels per roll	Rec. ribbon
i3300, i5300, BBP33	Fig. 4	B33-11-437	Matte White	0.250 (6.4)	0.250 (6.4)	0.250 (6.4)	0.375 (9.5)	3.200 (81.3)	12	15000	B30-R4300
i3300, i5300, BBP33	Fig. 1	B33-1-437	Matte White	0.750 (19.1)	0.250 (6.4)	0.800 (20.3)	0.350 (8.9)	3.350 (85.1)	4	5000	B30-R4300
i3300, i5300, BBP33	Fig. 1	B33-2-437	Matte White	0.900 (22.9)	0.250 (6.4)	1.125 (28.6)	0.350 (8.9)	3.350 (85.1)	3	5000	B30-R4300
i3300, i5300, BBP33	Fig. 1	B33-5-437	Matte White	1.000 (25.4)	0.500 (12.7)	1.075 (27.3)	0.600 (15.2)	3.350 (85.1)	3	5000	B30-R4300
i3300, i5300, BBP33	Fig. 1	B33-29-437	Matte White	1.250 (31.8)	0.375 (9.5)	1.300 (33.0)	0.475 (12.1)	2.750 (69.9)	2	5000	B30-R4300
i3300, i5300, BBP33	Fig. 1	B33-5-437YL	Matte Yellow	1.000 (25.4)	0.500 (12.7)	1.075 (27.3)	0.600 (15.2)	3.350 (85.1)	3	5000	B30-R4300
i3300, i5300, BBP33	Fig. 1	B33-29-437YL	Matte Yellow	1.250 (31.8)	0.375 (9.5)	1.300 (33.0)	0.475 (12.1)	2.750 (69.9)	2	5000	B30-R4300
Continuous rolls											
i3300, i5300, BBP33	Fig. 3a	B33C-1000-437	Matte White	1.000 (25.4)	85 ft. (25.9m)	-	-	1.200 (30.5)	1 roll (cont.)		B30-R4300
i3300, i5300, BBP33	Fig. 3a	B33C-1500-437	Matte White	1.500 (38.1)	85 ft. (25.9m)	-	-	1.900 (48.3)	1 roll (cont.)		B30-R4300
i3300, i5300, BBP33	Fig. 3a	B33C-2000-437	Matte White	2.000 (50.8)	85 ft. (25.9m)	-	-	2.200 (55.9)	1 roll (cont.)		B30-R4300
i3300, i5300, BBP33	Fig. 3a	B33C-3000-437	Matte White	3.000 (76.2)	85 ft. (25.9m)	-	-	3.400 (86.4)	1 roll (cont.)		B30-R4300
i3300, i5300, S3000, S3100, BBP30, BBP31, BBP33, BBP35, BBP37	Fig. 3a	B30C-4000-437	Matte White	4.000 (101.6)	100 ft. (30.5 m)	-	-	4.000 (101.6)	1 roll (cont.)		B30-R4300
i3300, i5300, BBP33	Fig. 3a	B33C-1000-437YL	Matte Yellow	1.000 (25.4)	85 ft. (25.9m)	-	-	1.200 (30.5)	1 roll (cont.)		B30-R4300
i3300, i5300, BBP33	Fig. 3a	B33C-1500-437YL	Matte Yellow	1.500 (38.1)	85 ft. (25.9m)	-	-	1.900 (48.3)	1 roll (cont.)		B30-R4300
i3300, i5300, BBP33	Fig. 3a	B33C-2000-437YL	Matte Yellow	2.000 (50.8)	85 ft. (25.9m)	-	-	2.200 (55.9)	1 roll (cont.)		B30-R4300
i3300, i5300, BBP33	Fig. 3a	B33C-3000-437YL	Matte Yellow	3.000 (76.2)	85 ft. (25.9m)	-	-	3.400 (86.4)	1 roll (cont.)		B30-R4300

High-Temp Flame-Retardant Polyimide Wire Wraps (B-472)

- Top-coated polyimide label for wire and cable marking where high temperature and self-extinguishing features are required
- Heavy-duty performance with excellent resistance to water, oil and other fluids
- Upper temp limit of up to 320°F – consult technical data sheet for full performance details

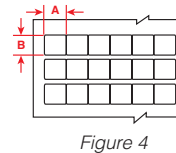
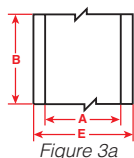
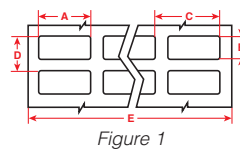

For Use with Printers:	Diagram	Catalog #	Color	Label width A inch (mm)	Label height B inch (mm)	Horiz. repeat C inch (mm)	Vert. repeat D inch (mm)	Web width E inch (mm)	Labels per row	Labels per roll	Rec. ribbon
i3300, i5300, BBP33	Fig. 4	B33-11-472	Matte White	0.250 (6.4)	0.250 (6.4)	0.250 (6.4)	0.375 (9.5)	3.200 (81.3)	12	15000	B30-R4300
i3300, i5300, BBP33	Fig. 1	B33-1-472	Matte White	0.750 (19.1)	0.250 (6.4)	0.800 (20.3)	0.350 (8.9)	3.350 (85.1)	4	5000	B30-R4300
i3300, i5300, BBP33	Fig. 1	B33-2-472	Matte White	0.900 (22.9)	0.250 (6.4)	1.125 (28.6)	0.350 (8.9)	3.350 (85.1)	3	5000	B30-R4300
i3300, i5300, BBP33	Fig. 1	B33-5-472	Matte White	1.000 (25.4)	0.500 (12.7)	1.075 (27.3)	0.600 (15.2)	3.350 (85.1)	3	5000	B30-R4300
i3300, i5300, BBP33	Fig. 1	B33-29-472	Matte White	1.250 (31.8)	0.375 (9.5)	1.300 (33.0)	0.475 (12.1)	2.750 (69.9)	2	5000	B30-R4300
i3300, i5300, BBP33	Fig. 1	B33-5-472YL	Matte Yellow	1.000 (25.4)	0.500 (12.7)	1.075 (27.3)	0.600 (15.2)	3.350 (85.1)	3	5000	B30-R4300
i3300, i5300, BBP33	Fig. 1	B33-29-472YL	Matte Yellow	1.250 (31.8)	0.375 (9.5)	1.300 (33.0)	0.475 (12.1)	2.750 (69.9)	2	5000	B30-R4300
Continuous rolls											
i3300, i5300, BBP33	Fig. 3a	B33C-1000-472	Matte White	1.000 (25.4)	85ft (25.9m)	-	-	1.200 (30.5)	1 roll (cont.)		B30-R4300
i3300, i5300, BBP33	Fig. 3a	B33C-1500-472	Matte White	1.500 (38.1)	85ft (25.9m)	-	-	1.900 (48.3)	1 roll (cont.)		B30-R4300
i3300, i5300, BBP33	Fig. 3a	B33C-2000-472	Matte White	2.000 (50.8)	85ft (25.9m)	-	-	2.200 (55.9)	1 roll (cont.)		B30-R4300
i3300, i5300, BBP33	Fig. 3a	B33C-3000-472	Matte White	3.000 (76.2)	85ft (25.9m)	-	-	3.400 (86.4)	1 roll (cont.)		B30-R4300
i3300, i5300, BBP33	Fig. 3a	B33C-1000-472YL	Matte Yellow	1.000 (25.4)	85ft (25.9m)	-	-	1.200 (30.5)	1 roll (cont.)		B30-R4300
i3300, i5300, BBP33	Fig. 3a	B33C-1500-472YL	Matte Yellow	1.500 (38.1)	85ft (25.9m)	-	-	1.900 (48.3)	1 roll (cont.)		B30-R4300
i3300, i5300, BBP33	Fig. 3a	B33C-2000-472YL	Matte Yellow	2.000 (50.8)	85ft (25.9m)	-	-	2.200 (55.9)	1 roll (cont.)		B30-R4300
i3300, i5300, BBP33	Fig. 3a	B33C-3000-472YL	Matte Yellow	3.000 (76.2)	85ft (25.9m)	-	-	3.400 (86.4)	1 roll (cont.)		B30-R4300

PermaSleeve® Heat-Shrink Sleeves (B-342)

- Standard military / industrial grade heat-shrinkable wire marker with 3:1 shrink ratio
- Can be used for identification or wire protection
- Fade-resistant and flame-retardant
- Meets SAE-AS-23053/5 and SAE-AS-81531 specs
- Tested per ASTM E162, ASTM E662 and MIL-STD-202

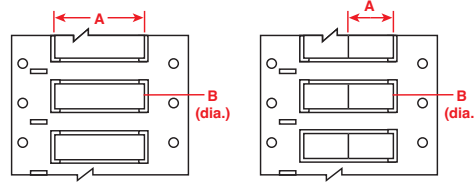
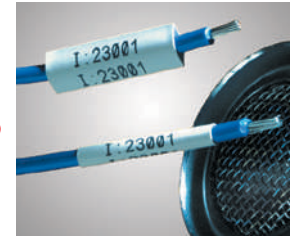

Figure 21

Figure 21-2



For Use with Printers:	Diagram	Catalog #	Color	For Wire Gauge (approx.)	For Wire Diameters Inch (mm) Min - Max.	Supplied Diameter B Inch (mm)	Recovered Diameter Inch (mm)	Recovered Wall Thickness Inch (mm)	Qty per Row	Qty per Roll	Rec. ribbon
3:1 Shrink ratio, single-side printable, 2" sleeve width (dimension A)											
i3300, i5300, BBP33	Fig. 21	B33-94-2-342	White	28 to 20	0.023 (0.6) - 0.080 (2.0)	0.094 (2.4)	0.024 (0.6)	.024 (0.6) +/- .003 (0.07)	1	1000	B30-R4300
i3300, i5300, BBP33	Fig. 21	B33-125-2-342	White	22 to 16	0.046 (1.2) - 1.110 (2.8)	0.125 (3.2)	0.047 (1.2)	.020 (0.5) +/- .003 (0.07)	1	1000	B30-R4300
i3300, i5300, BBP33	Fig. 21	B33-187-2-342	White	20 to 10	0.062 (1.6) - 0.150 (3.8)	0.187 (4.7)	0.062 (1.6)	.020 (0.5) +/- .003 (0.07)	1	750	B30-R4300
i3300, i5300, BBP33	Fig. 21	B33-250-2-342	White	16 to 8	0.094 (2.4) - 0.215 (5.5)	0.250 (6.4)	0.093 (2.4)	.025 (0.6) +/- .003 (0.07)	1	500	B30-R4300
i3300, i5300, BBP33	Fig. 21	B33-375-2-342	White	12 to 4	0.125 (3.2) - 0.320 (8.1)	0.375 (9.5)	0.125 (3.1)	.025 (0.6) +/- .003 (0.07)	1	500	B30-R4300
i3300, i5300, BBP33	Fig. 21	B33-500-2-342	White	8 to 1	0.187 (4.8) - 0.450 (11.4)	0.500 (12.7)	0.187 (4.7)	.025 (0.6) +/- .003 (0.07)	1	350	B30-R4300
i3300, i5300, BBP33	Fig. 21	B33-750-2-342	White	6 to 4/0	0.250 (6.4) - 0.700 (17.8)	0.750 (19.1)	0.250 (6.4)	.025 (0.6) +/- .003 (0.07)	1	250	B30-R4300
i3300, i5300, BBP33	Fig. 21	B33-1000-2-342	White	2 to 0.950 dia	0.333 (8.5) - 0.950 (24.1)	1.000 (25.4)	0.375 (9.5)	.036 (0.9) +/- .003 (0.07)	1	250	B30-R4300
i3300, i5300, BBP33	Fig. 21	B33-1500-2-342	White	n/a	0.500 (12.7) - 1.400 (35.6)	1.500 (38.1)	0.500 (12.7)	.035 (0.9) +/- .003 (0.07)	1	150	B30-R4300
i3300, i5300, BBP33	Fig. 21	B33-94-2-342YL	Yellow	28 to 20	0.023 (0.6) - 0.080 (2.0)	0.094 (2.4)	0.024 (0.6)	.024 (0.6) +/- .003 (0.07)	1	1000	B30-R4300
i3300, i5300, BBP33	Fig. 21	B33-125-2-342YL	Yellow	22 to 16	0.046 (1.2) - 1.110 (2.8)	0.125 (3.2)	0.047 (1.2)	.020 (0.5) +/- .003 (0.07)	1	1000	B30-R4300
i3300, i5300, BBP33	Fig. 21	B33-187-2-342YL	Yellow	20 to 10	0.062 (1.6) - 0.150 (3.8)	0.187 (4.7)	0.062 (1.6)	.020 (0.5) +/- .003 (0.07)	1	750	B30-R4300
i3300, i5300, BBP33	Fig. 21	B33-250-2-342YL	Yellow	16 to 8	0.094 (2.4) - 0.215 (5.5)	0.250 (6.4)	0.093 (2.4)	.025 (0.6) +/- .003 (0.07)	1	500	B30-R4300
i3300, i5300, BBP33	Fig. 21	B33-375-2-342YL	Yellow	12 to 4	0.125 (3.2) - 0.320 (8.1)	0.375 (9.5)	0.125 (3.1)	.025 (0.6) +/- .003 (0.07)	1	500	B30-R4300
i3300, i5300, BBP33	Fig. 21	B33-500-2-342YL	Yellow	8 to 1	0.187 (4.8) - 0.450 (11.4)	0.500 (12.7)	0.187 (4.7)	.025 (0.6) +/- .003 (0.07)	1	350	B30-R4300
i3300, i5300, BBP33	Fig. 21	B33-750-2-342YL	Yellow	6 to 4/0	0.250 (6.4) - 0.700 (17.8)	0.750 (19.1)	0.250 (6.4)	.025 (0.6) +/- .003 (0.07)	1	250	B30-R4300
i3300, i5300, BBP33	Fig. 21	B33-1000-2-342YL	Yellow	2 to 0.950 dia	0.333 (8.5) - 0.950 (24.1)	1.000 (25.4)	0.375 (9.5)	.036 (0.9) +/- .003 (0.07)	1	250	B30-R4300
i3300, i5300, BBP33	Fig. 21	B33-1500-2-342YL	Yellow	n/a	0.500 (12.7) - 1.400 (35.6)	1.500 (38.1)	0.500 (12.7)	.035 (0.9) +/- .003 (0.07)	1	150	B30-R4300
i3300, i5300, BBP33	Fig. 21	B33-1500-2-342BK	Black	n/a	0.500 (12.7) - 1.400 (35.6)	1.500 (38.1)	0.500 (12.7)	.035 (0.9) +/- .003 (0.07)	1	150	B30-R4500-SV
3:1 Shrink ratio, single-side printable, 1" sleeve width in "2-across precut" configuration (dimension A)											
i3300, i5300, BBP33	Fig. 21-2	B33-94-2-342-2	White	28 to 20	0.023 (0.6) - 0.080 (2.0)	0.094 (2.4)	0.024 (0.6)	.024 (0.6) +/- .003 (0.07)	2	2000	B30-R4300
i3300, i5300, BBP33	Fig. 21-2	B33-125-2-342-2	White	22 to 16	0.046 (1.2) - 0.111 (2.8)	0.125 (3.2)	0.047 (1.2)	.020 (0.5) +/- .003 (0.07)	2	2000	B30-R4300
i3300, i5300, BBP33	Fig. 21-2	B33-187-2-342-2	White	20 to 10	0.062 (1.6) - 0.150 (3.8)	0.187 (4.7)	0.062 (1.6)	.020 (0.5) +/- .003 (0.07)	2	1500	B30-R4300
i3300, i5300, BBP33	Fig. 21-2	B33-250-2-342-2	White	16 to 8	0.094 (2.4) - 0.215 (5.5)	0.250 (6.4)	0.093 (2.4)	.025 (0.6) +/- .003 (0.07)	2	1000	B30-R4300
i3300, i5300, BBP33	Fig. 21-2	B33-375-2-342-2	White	12 to 4	0.125 (3.2) - 0.320 (8.1)	0.375 (9.5)	0.125 (3.1)	.025 (0.6) +/- .003 (0.07)	2	1000	B30-R4300
i3300, i5300, BBP33	Fig. 21-2	B33-500-2-342-2	White	8 to 1	0.187 (4.8) - 0.450 (11.4)	0.500 (12.7)	0.119 (3.0)	.025 (0.6) +/- .003 (0.07)	2	700	B30-R4300
i3300, i5300, BBP33	Fig. 21-2	B33-750-2-342-2	White	6 to 4/0	0.250 (6.4) - 0.700 (17.8)	0.750 (19.1)	0.250 (6.35)	.025 (0.6) +/- .003 (0.07)	2	500	B30-R4300
i3300, i5300, BBP33	Fig. 21-2	B33-1000-2-342-2	White	2 to 0.950 dia	0.333 (8.5) - 0.950 (24.1)	1.000 (25.4)		.036 (0.9) +/- .003 (0.07)	2	500	B30-R4300
i3300, i5300, BBP33	Fig. 21-2	B33-1500-2-342-2	White	n/a	0.500 (12.7) - 1.400 (35.6)	1.500 (38.1)	0.500 (12.7)	.035 (0.9) +/- .003 (0.07)	2	150	B30-R4300
i3300, i5300, BBP33	Fig. 21-2	B33-94-2-342YL-2	Yellow	28 to 20	0.023 (0.6) - 0.080 (2.0)	0.094 (2.4)	0.024 (0.6)	.024 (0.6) +/- .003 (0.07)	2	2000	B30-R4300
i3300, i5300, BBP33	Fig. 21-2	B33-125-2-342YL-2	Yellow	22 to 16	0.046 (1.2) - 0.111 (2.8)	0.125 (3.2)	0.047 (1.2)	.020 (0.5) +/- .003 (0.07)	2	2000	B30-R4300
i3300, i5300, BBP33	Fig. 21-2	B33-750-2-342YL-2	Yellow	6 to 4/0	0.250 (6.4) - 0.700 (17.8)	0.750 (19.1)	0.250 (6.35)	.025 (0.6) +/- .003 (0.07)	2	500	B30-R4300
i3300, i5300, BBP33	Fig. 21-2	B33-500-2-342YL-2	Yellow	8 to 1	0.187 (4.8) - 0.450 (11.4)	0.500 (12.7)	0.119 (3.0)	.025 (0.6) +/- .003 (0.07)	2	700	B30-R4300
i3300, i5300, BBP33	Fig. 21-2	B33-1000-2-342YL-2	Yellow	2 to 0.950 dia	0.333 (8.5) - 0.950 (24.1)	1.000 (25.4)	0.375 (9.5)	.036 (0.9) +/- .003 (0.07)	2	500	B30-R4300
i3300, i5300, BBP33	Fig. 21-2	B33-1500-2-342YL-2	Yellow	n/a	0.500 (12.7) - 1.400 (35.6)	1.500 (38.1)	0.500 (12.7)	.035 (0.9) +/- .003 (0.07)	2	300	B30-R4300

For Use with Printers:	Diagram	Catalog #	Color	For Wire Gauge (approx.)	For Wire Diameters Inch (mm) Min - Max.	Supplied Diameter B Inch (mm)	Recovered Diameter Inch (mm)	Recovered Wall Thickness Inch (mm)	Qty per Row	Qty per Roll	Rec. ribbon
3:1 Shrink ratio, Double-side printable, 2" sleeve width (dimension A)											
i3300, i5300, BBP33	Fig. 21	B33D-94-2-342	White	28 to 20	0.023 (0.6) - 0.080 (2.0)	0.094 (2.4)	0.024 (0.6)	.024 (0.6) +/- .003 (0.07)	1	1000	B30-R4300
i3300, i5300, BBP33	Fig. 21	B33D-94-2-342	White	22 to 16	0.046 (1.2) - 1.110 (2.8)	0.125 (3.2)	0.047 (1.2)	.020 (0.5) +/- .003 (0.07)	1	1000	B30-R4300
i3300, i5300, BBP33	Fig. 21	B33D-125-2-342	White	22 to 16	0.046 (1.2) - 1.110 (2.8)	0.125 (3.2)	0.047 (1.2)	.020 (0.5) +/- .003 (0.07)	1	1000	B30-R4300
i3300, i5300, BBP33	Fig. 21	B33D-187-2-342	White	20 to 10	0.062 (1.6) - 0.150 (3.8)	0.187 (4.7)	0.062 (1.6)	.020 (0.5) +/- .003 (0.07)	1	750	B30-R4300
i3300, i5300, BBP33	Fig. 21	B33D-250-2-342	White	16 to 8	0.094 (2.4) - 0.215 (5.5)	0.250 (6.4)	0.093 (2.4)	.025 (0.6) +/- .003 (0.07)	1	500	B30-R4300
i3300, i5300, BBP33	Fig. 21	B33D-375-2-342	White	12 to 4	0.125 (3.2) - 0.320 (8.1)	0.375 (9.5)	0.125 (3.1)	.025 (0.6) +/- .003 (0.07)	1	500	B30-R4300
i3300, i5300, BBP33	Fig. 21	B33D-500-2-342	White	8 to 1	0.187 (4.8) - 0.450 (11.4)	0.500 (12.7)	0.187 (4.7)	.025 (0.6) +/- .003 (0.07)	1	350	B30-R4300
i3300, i5300, BBP33	Fig. 21	B33D-750-2-342	White	6 to 4/0	0.250 (6.4) - 0.700 (17.8)	0.750 (19.1)	0.250 (6.4)	.025 (0.6) +/- .003 (0.07)	1	250	B30-R4300
i3300, i5300, BBP33	Fig. 21	B33D-1000-2-342	White	2 to 0.950 dia	0.333 (8.5) - 0.950 (24.1)	1.000 (25.4)	0.375 (9.5)	.036 (0.9) +/- .003 (0.07)	1	250	B30-R4300
i3300, i5300, BBP33	Fig. 21	B33D-1500-2-342	White	n/a	0.500 (12.7) - 1.400 (35.6)	1.500 (38.1)	0.500 (12.7)	.035 (0.9) +/- .003 (0.07)	1	150	B30-R4300
i3300, i5300, BBP33	Fig. 21	B33D-94-2-342YL	Yellow	28 to 20	0.023 (0.6) - 0.080 (2.0)	0.094 (2.4)	0.024 (0.6)	.024 (0.6) +/- .003 (0.07)	1	1000	B30-R4300
i3300, i5300, BBP33	Fig. 21	B33D-125-2-342YL	Yellow	22 to 16	0.046 (1.2) - 1.110 (2.8)	0.125 (3.2)	0.047 (1.2)	.020 (0.5) +/- .003 (0.07)	1	1000	B30-R4300
i3300, i5300, BBP33	Fig. 21	B33D-187-2-342YL	Yellow	20 to 10	0.062 (1.6) - 0.150 (3.8)	0.187 (4.7)	0.062 (1.6)	.020 (0.5) +/- .003 (0.07)	1	750	B30-R4300
i3300, i5300, BBP33	Fig. 21	B33D-250-2-342YL	Yellow	16 to 8	0.094 (2.4) - 0.215 (5.5)	0.250 (6.4)	0.093 (2.4)	.025 (0.6) +/- .003 (0.07)	1	500	B30-R4300
i3300, i5300, BBP33	Fig. 21	B33D-375-2-342YL	Yellow	12 to 4	0.125 (3.2) - 0.320 (8.1)	0.375 (9.5)	0.125 (3.1)	.025 (0.6) +/- .003 (0.07)	1	500	B30-R4300
i3300, i5300, BBP33	Fig. 21	B33D-500-2-342YL	Yellow	8 to 1	0.187 (4.8) - 0.450 (11.4)	0.500 (12.7)	0.187 (4.7)	.025 (0.6) +/- .003 (0.07)	1	350	B30-R4300
i3300, i5300, BBP33	Fig. 21	B33D-750-2-342YL	Yellow	6 to 4/0	0.250 (6.4) - 0.700 (17.8)	0.750 (19.1)	0.250 (6.4)	.025 (0.6) +/- .003 (0.07)	1	250	B30-R4300
i3300, i5300, BBP33	Fig. 21	B33D-1000-2-342YL	Yellow	2 to 0.950 dia	0.333 (8.5) - 0.950 (24.1)	1.000 (25.4)	0.375 (9.5)	.036 (0.9) +/- .003 (0.07)	1	250	B30-R4300
i3300, i5300, BBP33	Fig. 21	B33D-1500-2-342YL	Yellow	n/a	0.500 (12.7) - 1.400 (35.6)	1.500 (38.1)	0.500 (12.7)	.035 (0.9) +/- .003 (0.07)	1	150	B30-R4300
i3300, i5300, BBP33	Fig. 21	B33D-94-2-342BK	Black	28 to 20	0.023 (0.6) - 0.080 (2.0)	0.094 (2.4)	0.024 (0.6)	.024 (0.6) +/- .003 (0.07)	1	1000	B30-R4500-SV
i3300, i5300, BBP33	Fig. 21	B33D-125-2-342BK	Black	22 to 16	0.046 (1.2) - 1.110 (2.8)	0.125 (3.2)	0.047 (1.2)	.020 (0.5) +/- .003 (0.07)	1	1000	B30-R4500-SV
i3300, i5300, BBP33	Fig. 21	B33D-187-2-342BK	Black	20 to 10	0.062 (1.6) - 0.150 (3.8)	0.187 (4.7)	0.062 (1.6)	.020 (0.5) +/- .003 (0.07)	1	750	B30-R4500-SV
i3300, i5300, BBP33	Fig. 21	B33D-250-2-342BK	Black	16 to 8	0.094 (2.4) - 0.215 (5.5)	0.250 (6.4)	0.093 (2.4)	.025 (0.6) +/- .003 (0.07)	1	500	B30-R4500-SV
i3300, i5300, BBP33	Fig. 21	B33D-375-2-342BK	Black	12 to 4	0.125 (3.2) - 0.320 (8.1)	0.375 (9.5)	0.125 (3.1)	.025 (0.6) +/- .003 (0.07)	1	500	B30-R4500-SV
i3300, i5300, BBP33	Fig. 21	B33D-500-2-342BK	Black	8 to 1	0.187 (4.8) - 0.450 (11.4)	0.500 (12.7)	0.187 (4.7)	.025 (0.6) +/- .003 (0.07)	1	350	B30-R4500-SV
i3300, i5300, BBP33	Fig. 21	B33D-750-2-342BK	Black	6 to 4/0	0.250 (6.4) - 0.700 (17.8)	0.750 (19.1)	0.250 (6.4)	.025 (0.6) +/- .003 (0.07)	1	250	B30-R4500-SV
i3300, i5300, BBP33	Fig. 21	B33D-1000-2-342BK	Black	2 to 0.950 dia	0.333 (8.5) - 0.950 (24.1)	1.000 (25.4)	0.375 (9.5)	.036 (0.9) +/- .003 (0.07)	1	250	B30-R4500-SV
i3300, i5300, BBP33	Fig. 21	B33D-1500-2-342BK	Black	n/a	0.500 (12.7) - 1.400 (35.6)	1.500 (38.1)	0.500 (12.7)	.035 (0.9) +/- .003 (0.07)	1	150	B30-R4500-SV

2-pass double-side sleeve printing with no wasted sleeves using i5300 printer and Brady Workstation

- Use double-sided sleeve module in Brady workstation
- Change text content, size and even rotation for each side!
- See a demo at BradyId.com



PermaSleeve® Fluid-Resistant Heat-Shrink Sleeves (B-344)

- Designed for labeling wires with exposure to fuels, lubricants and harsh chemicals such as in the installation of hydrogen fuel cells in aerospace
- Resistant to harsh chemicals including JP8 Jet Fuel, Skydrol® and DOT 3 brake fluid
- Meets SAE-AS23053/5
- Tested per: ASTM E162, ASTM E662, MIL-STD-202G

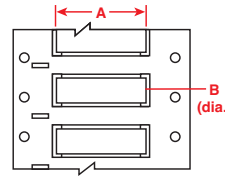
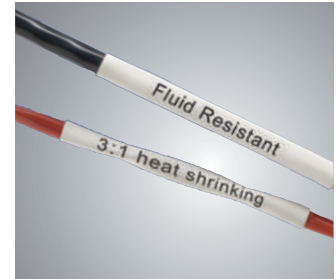

Figure 21



For Use with Printers:	Diagram	Catalog #	Color	For Wire Gauge (approx.)	For Wire Diameters Inch (mm) Min - Max.	Supplied Diameter B Inch (mm)	Recovered Diameter Inch (mm)	Recovered Wall Thickness Inch (mm)	Qty per Row	Qty per Roll	Rec. ribbon
3:1 Shrink ratio, Double-side printable, 2" sleeve width (dimension A)											
i3300, i5300, BBP33	Fig. 21	B33D-94-2-344	White	28 to 20	0.023 (0.6) - 0.080 (2.0)	0.094 (2.4)	0.024 (0.6)	0.024 (0.6) +/- 0.003 (0.1)	1	1000	B30-R6600
i3300, i5300, BBP33	Fig. 21	B33D-125-2-344	White	22 to 16	0.046 (1.2) - 0.111 (2.8)	0.125 (3.1)	0.047 (1.2)	0.020 (0.5) +/- 0.003 (0.1)	1	1000	B30-R6600
i3300, i5300, BBP33	Fig. 21	B33D-187-2-344	White	20 to 10	0.062 (1.6) - 0.15 (3.81)	0.187 (4.8)	0.062 (1.6)	0.020 (0.5) +/- 0.003 (0.1)	1	750	B30-R6600
i3300, i5300, BBP33	Fig. 21	B33D-250-2-344	White	16 to 8	0.094 (2.4) - 0.215 (5.5)	0.250 (6.35)	0.093 (2.4)	0.025 (0.6) +/- 0.003 (0.1)	1	500	B30-R6600
i3300, i5300, BBP33	Fig. 21	B33D-375-2-344	White	12 to 4	0.125 (3.2) - 0.320 (8.1)	0.375 (9.5)	0.125 (3.2)	0.025 (0.6) +/- 0.003 (0.1)	1	500	B30-R6600
i3300, i5300, BBP33	Fig. 21	B33D-500-2-344	White	8 to 1	0.187 (4.8) - 0.450 (11.4)	0.500 (12.7)	0.119 (3.0)	0.025 (0.6) +/- 0.003 (0.1)	1	350	B30-R6600
i3300, i5300, BBP33	Fig. 21	B33D-750-2-344	White	6 to 4/0	0.250 (6.4) - 0.700 (17.8)	0.750 (19.05)	0.250 (6.35)	0.025 (0.6) +/- 0.003 (0.1)	1	250	B30-R6600
i3300, i5300, BBP33	Fig. 21	B33D-1000-2-344	White	2 to 0.950 dia	0.333 (8.5) - 0.950 (24.1)	1.000 (25.4)	0.375 (9.5)	0.036 (0.9) +/- 0.003 (0.1)	1	250	B30-R6600
i3300, i5300, BBP33	Fig. 21	B33D-1500-2-344	White	n/a	0.500 (12.7) - 1.400 (35.6)	1.500 (38.1)	0.500 (12.7)	0.035 (0.9) +/- 0.003 (0.1)	1	150	B30-R6600
i3300, i5300, BBP33	Fig. 21	B33D-94-2-344YL	Yellow	28 to 20	0.023 (0.6) - 0.080 (2.0)	0.094 (2.4)	0.024 (0.6)	0.024 (0.6) +/- 0.003 (0.1)	1	1000	B30-R6600
i3300, i5300, BBP33	Fig. 21	B33D-125-2-344YL	Yellow	22 to 16	0.046 (1.2) - 0.111 (2.8)	0.125 (3.1)	0.047 (1.2)	0.020 (0.5) +/- 0.003 (0.1)	1	1000	B30-R6600
i3300, i5300, BBP33	Fig. 21	B33D-187-2-344YL	Yellow	20 to 10	0.062 (1.6) - 0.15 (3.81)	0.187 (4.8)	0.062 (1.6)	0.020 (0.5) +/- 0.003 (0.1)	1	750	B30-R6600
i3300, i5300, BBP33	Fig. 21	B33D-250-2-344YL	Yellow	16 to 8	0.094 (2.4) - 0.215 (5.5)	0.250 (6.35)	0.093 (2.4)	0.025 (0.6) +/- 0.003 (0.1)	1	500	B30-R6600
i3300, i5300, BBP33	Fig. 21	B33D-375-2-344YL	Yellow	12 to 4	0.125 (3.2) - 0.320 (8.1)	0.375 (9.5)	0.125 (3.2)	0.025 (0.6) +/- 0.003 (0.1)	1	500	B30-R6600
i3300, i5300, BBP33	Fig. 21	B33D-500-2-344YL	Yellow	8 to 1	0.187 (4.8) - 0.450 (11.4)	0.500 (12.7)	0.119 (3.0)	0.025 (0.6) +/- 0.003 (0.1)	1	350	B30-R6600
i3300, i5300, BBP33	Fig. 21	B33D-750-2-344YL	Yellow	6 to 4/0	0.250 (6.4) - 0.700 (17.8)	0.750 (19.05)	0.250 (6.35)	0.025 (0.6) +/- 0.003 (0.1)	1	250	B30-R6600
i3300, i5300, BBP33	Fig. 21	B33D-1000-2-344YL	Yellow	2 to 0.950 dia	0.333 (8.5) - 0.950 (24.1)	1.000 (25.4)	0.375 (9.5)	0.036 (0.9) +/- 0.003 (0.1)	1	250	B30-R6600
i3300, i5300, BBP33	Fig. 21	B33D-1500-2-344YL	Yellow	n/a	0.500 (12.7) - 1.400 (35.6)	1.500 (38.1)	0.500 (12.7)	0.035 (0.9) +/- 0.003 (0.1)	1	150	B30-R6600
i3300, i5300, BBP33	Fig. 21	B33D-94-2-344BK	Black	28 to 20	0.023 (0.6) - 0.080 (2.0)	0.094 (2.4)	0.024 (0.6)	0.024 (0.6) +/- 0.003 (0.1)	1	1000	B30-R6700-WT
i3300, i5300, BBP33	Fig. 21	B33D-125-2-344BK	Black	22 to 16	0.046 (1.2) - 0.111 (2.8)	0.125 (3.1)	0.047 (1.2)	0.020 (0.5) +/- 0.003 (0.1)	1	1000	B30-R6700-WT
i3300, i5300, BBP33	Fig. 21	B33D-187-2-344BK	Black	20 to 10	0.062 (1.6) - 0.15 (3.81)	0.187 (4.8)	0.062 (1.6)	0.020 (0.5) +/- 0.003 (0.1)	1	750	B30-R6700-WT
i3300, i5300, BBP33	Fig. 21	B33D-250-2-344BK	Black	16 to 8	0.094 (2.4) - 0.215 (5.5)	0.250 (6.35)	0.093 (2.4)	0.025 (0.6) +/- 0.003 (0.1)	1	500	B30-R6700-WT
i3300, i5300, BBP33	Fig. 21	B33D-375-2-344BK	Black	12 to 4	0.125 (3.2) - 0.320 (8.1)	0.375 (9.5)	0.125 (3.2)	0.025 (0.6) +/- 0.003 (0.1)	1	500	B30-R6700-WT
i3300, i5300, BBP33	Fig. 21	B33D-500-2-344BK	Black	8 to 1	0.187 (4.8) - 0.450 (11.4)	0.500 (12.7)	0.119 (3.0)	0.025 (0.6) +/- 0.003 (0.1)	1	350	B30-R6700-WT
i3300, i5300, BBP33	Fig. 21	B33D-750-2-344BK	Black	6 to 4/0	0.250 (6.4) - 0.700 (17.8)	0.750 (19.05)	0.250 (6.35)	0.025 (0.6) +/- 0.003 (0.1)	1	250	B30-R6700-WT
i3300, i5300, BBP33	Fig. 21	B33D-1000-2-344BK	Black	2 to 0.950 dia	0.333 (8.5) - 0.950 (24.1)	1.000 (25.4)	0.375 (9.5)	0.036 (0.9) +/- 0.003 (0.1)	1	250	B30-R6700-WT
i3300, i5300, BBP33	Fig. 21	B33D-1500-2-344BK	Black	n/a	0.500 (12.7) - 1.400 (35.6)	1.500 (38.1)	0.500 (12.7)	0.035 (0.9) +/- 0.003 (0.1)	1	150	B30-R6700-WT

PermaSleeve® High-Temp Heat-Shrink Sleeves (B-345)

- A 2:1 shrink ratio wire marker sleeve specifically designed for high-temperature and low-vacuum outgassing applications
- Made from irradiated high-temp polyvinylidene fluoride (PVDF) heat-shrink tubing
- Fade-resistant and flame-retardant
- Meets NASA SP-R-0022A Outgassing Performance
- Meets SAE-AS-81531
- Tested per ASTM E162, ASTM E662 and MIL-STD-202

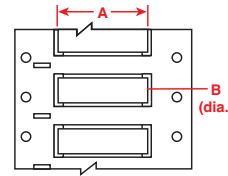

Figure 21



For Use with Printers:	Diagram	Catalog #	Color	For Wire Gauge (approx.)	For Wire Diameters Inch (mm) Min - Max.	Supplied Diameter B Inch (mm)	Recovered Diameter Inch (mm)	Recovered Wall Thickness Inch (mm)	Qty per Row	Qty per Roll	Rec. ribbon
3:1 Shrink ratio double-side printable, 2 in. sleeve width (dimension A)											
i3300, i5300, BBP33	Fig. 21	B33D-94-2-345	White	26 to 20	0.031 (0.8) - 0.080 (2.0)	0.094 (2.4)	0.031 (0.8)	.015 (0.4) +/- .003 (0.07)	1	1000	B30-R6000
i3300, i5300, BBP33	Fig. 21	B33D-94-2-345BK	Black	26 to 20	0.031 (0.8) - 0.080 (2.0)	0.094 (2.4)	0.031 (0.8)	.015 (0.4) +/- .003 (0.07)	1	1000	B30-R4400-WT
2:1 Shrink ratio double-side printable, 2 in. sleeve width (dimension A)											
i3300, i5300, BBP33	Fig. 21	B33D-125-2-345	White	20 to 16	0.063 (1.6) - 0.110 (2.8)	0.125 (3.2)	0.062 (1.6)	.015 (0.4) +/- .003 (0.07)	1	1000	B30-R6000
i3300, i5300, BBP33	Fig. 21	B33D-187-2-345	White	16 to 10	0.094 (2.4) - 0.150 (3.8)	0.187 (4.7)	0.093 (2.4)	.015 (0.4) +/- .003 (0.07)	1	750	B30-R6000
i3300, i5300, BBP33	Fig. 21	B33D-250-2-345	White	12 to 8	0.125 (3.2) - 0.215 (5.5)	0.250 (6.4)	0.125 (3.2)	.015 (0.4) +/- .003 (0.07)	1	500	B30-R6000
i3300, i5300, BBP33	Fig. 21	B33D-375-2-345	White	8 to 4	0.187 (3.2) - 0.320 (8.1)	0.375 (9.5)	0.187 (4.7)	.015 (0.4) +/- .003 (0.07)	1	500	B30-R6000
i3300, i5300, BBP33	Fig. 21	B33D-500-2-345	White	6 to 1	0.250 (6.4) - 0.450 (11.4)	0.500 (12.7)	0.250 (6.4)	.015 (0.4) +/- .003 (0.07)	1	350	B30-R6000
i3300, i5300, BBP33	Fig. 21	B33D-750-2-345	White	2 to 4/0	0.375 (9.5) - 0.700 (17.8)	0.750 (19.1)	0.375 (9.5)	.015 (0.4) +/- .003 (0.07)	1	250	B30-R6000
i3300, i5300, BBP33	Fig. 21	B33D-1000-2-345	White	2/0 to 0.950 dia	0.450 (11.4) - 0.950 (24.1)	1.000 (25.4)	0.500 (12.7)	.017 (0.4) +/- .004 (0.1)	1	250	B30-R6000
i3300, i5300, BBP33	Fig. 21	B33D-1500-2-345	White	N/A	0.750 (19.1) - 1.400 (35.6)	1.500 (38.1)	0.750 (19.1)	.024 (0.6) +/- .004 (0.1)	1	150	B30-R6000
i3300, i5300, BBP33	Fig. 21	B33D-125-2-345BK	Black	20 to 16	0.063 (1.6) - 0.110 (2.8)	0.125 (3.2)	0.062 (1.6)	.015 (0.4) +/- .003 (0.07)	1	1000	B30-R4400-WT
i3300, i5300, BBP33	Fig. 21	B33D-187-2-345BK	Black	16 to 10	0.094 (2.4) - 0.150 (3.8)	0.187 (4.7)	0.093 (2.4)	.015 (0.4) +/- .003 (0.07)	1	750	B30-R4400-WT
i3300, i5300, BBP33	Fig. 21	B33D-250-2-345BK	Black	12 to 8	0.125 (3.2) - 0.215 (5.5)	0.250 (6.4)	0.125 (3.2)	.015 (0.4) +/- .003 (0.07)	1	500	B30-R4400-WT
i3300, i5300, BBP33	Fig. 21	B33D-375-2-345BK	Black	8 to 4	0.187 (3.2) - 0.320 (8.1)	0.375 (9.5)	0.187 (4.7)	.015 (0.4) +/- .003 (0.07)	1	500	B30-R4400-WT
i3300, i5300, BBP33	Fig. 21	B33D-500-2-345BK	Black	6 to 1	0.250 (6.4) - 0.450 (11.4)	0.500 (12.7)	0.250 (6.4)	.015 (0.4) +/- .003 (0.07)	1	350	B30-R4400-WT
i3300, i5300, BBP33	Fig. 21	B33D-750-2-345BK	Black	3 to 4/0	0.375 (9.5) - 0.700 (17.8)	0.750 (19.1)	0.375 (9.5)	.015 (0.4) +/- .003 (0.07)	1	250	B30-R4400-WT
i3300, i5300, BBP33	Fig. 21	B33D-1000-2-345BK	Black	2/0 to 0.950 dia	0.450 (11.4) - 0.950 (24.1)	1.000 (25.4)	0.500 (12.7)	.017 (0.4) +/- .004 (0.1)	1	250	B30-R4400-WT
i3300, i5300, BBP33	Fig. 21	B33D-1500-2-345BK	Black	N/A	0.750 (19.1) - 1.400 (35.6)	1.500 (38.1)	0.750 (19.1)	.024 (0.6) +/- .004 (0.1)	1	150	B30-R4400-WT

PermaSleeve® Low Smoke Zero Halogen Heat-Shrink Sleeves (B-7641)

- Low halogen wire marking sleeves offer outstanding fire safety properties and minimal smoke emission
- Meets SAE-AS-81531 and EN45545-2
- Tested per ASTM E162, ASTM E662 and MIL-STD-202

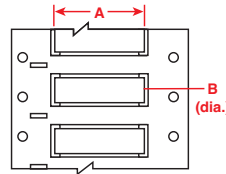

Figure 21



For Use with Printers:	Diagram	Catalog #	Color	For Wire Gauge (approx.)	For Wire Diameters Inch (mm) Min - Max.	Supplied Diameter B Inch (mm)	Recovered Diameter Inch (mm)	Recovered Wall Thickness Inch (mm)	Qty per Row	Qty per Roll	Rec. ribbon
2:1 Shrink ratio double-side printable, 2 in. sleeve width (dimension A)											
i3300, i5300, BBP33	Fig. 21	B33D-94-2-7641	White	24 to 20	0.047 (1.2) - 0.080 (2.0)	0.094 (2.4)	0.047 (1.2)	.020 (0.5) +/- .003 (0.07)	1	500	B30-R6000
i3300, i5300, BBP33	Fig. 21	B33D-125-2-7641	White	20 to 16	0.062 (1.6) - 0.110 (2.8)	0.125 (3.2)	0.063 (1.6)	.020 (0.5) +/- .003 (0.07)	1	500	B30-R6000
i3300, i5300, BBP33	Fig. 21	B33D-187-2-7641	White	16 to 10	0.094 (2.4) - 0.151 (3.8)	0.187 (4.8)	0.094 (2.4)	.020 (0.5) +/- .003 (0.07)	1	450	B30-R6000
i3300, i5300, BBP33	Fig. 21	B33D-250-2-7641	White	12 to 8	0.125 (3.2) - 0.215 (5.5)	0.250 (6.4)	0.126 (3.2)	.025 (0.6) +/- .003 (0.07)	1	400	B30-R6000
i3300, i5300, BBP33	Fig. 21	B33D-375-2-7641	White	8 to 4	0.188 (4.8) - .0320 (8.1)	0.375 (9.5)	0.189 (4.8)	.025 (0.6) +/- .003 (0.07)	1	250	B30-R6000
i3300, i5300, BBP33	Fig. 21	B33D-500-2-7641	White	6 to 1	0.250 (6.4) - 0.450 (11.4)	0.500 (12.7)	0.252 (6.4)	.025 (0.6) +/- .003 (0.07)	1	225	B30-R6000
i3300, i5300, BBP33	Fig. 21	B33D-750-2-7641	White	2 to 4/0	0.375 (9.5) - 0.700 (17.8)	0.750 (19.1)	0.374 (9.5)	.030 (0.8) +/- .003 (0.07)	1	150	B30-R6000
i3300, i5300, BBP33	Fig. 21	B33D-1000-2-7641	White	2/0 to 0.950 dia	0.450 (11.4) - 0.950 (24.1)	1.000 (25.4)	0.500 (12.7)	.035 (0.9) +/- .005 (0.1)	1	150	B30-R6000
i3300, i5300, BBP33	Fig. 21	B33D-1500-2-7641	White	N/A	0.750 (19.1) - 1.400 (35.6)	1.500 (38.1)	0.752 (19.1)	.040 (1.0) +/- .006 (0.2)	1	50	B30-R6000
i3300, i5300, BBP33	Fig. 21	B33D-94-2-7641Y	Yellow	24 to 20	0.047 (1.2) - 0.080 (2.0)	0.094 (2.4)	0.047 (1.2)	.020 (0.5) +/- .003 (0.07)	1	500	B30-R6000
i3300, i5300, BBP33	Fig. 21	B33D-125-2-7641Y	Yellow	20 to 16	0.062 (1.6) - 0.110 (2.8)	0.125 (3.2)	0.063 (1.6)	.020 (0.5) +/- .003 (0.07)	1	500	B30-R6000
i3300, i5300, BBP33	Fig. 21	B33D-187-2-7641Y	Yellow	16 to 10	0.094 (2.4) - 0.151 (3.8)	0.187 (4.8)	0.094 (2.4)	.020 (0.5) +/- .003 (0.07)	1	450	B30-R6000
i3300, i5300, BBP33	Fig. 21	B33D-250-2-7641Y	Yellow	12 to 8	0.125 (3.2) - 0.215 (5.5)	0.250 (6.4)	0.126 (3.2)	.025 (0.6) +/- .003 (0.07)	1	450	B30-R6000
i3300, i5300, BBP33	Fig. 21	B33D-375-2-7641Y	Yellow	8 to 4	0.188 (4.8) - .0320 (8.1)	0.375 (9.5)	0.189 (4.8)	.025 (0.6) +/- .003 (0.07)	1	250	B30-R6000
i3300, i5300, BBP33	Fig. 21	B33D-500-2-7641Y	Yellow	6 to 1	0.250 (6.4) - 0.450 (11.4)	0.500 (12.7)	0.252 (6.4)	.025 (0.6) +/- .003 (0.07)	1	225	B30-R6000
i3300, i5300, BBP33	Fig. 21	B33D-750-2-7641Y	Yellow	2 to 4/0	0.375 (9.5) - 0.700 (17.8)	0.750 (19.1)	0.374 (9.5)	.030 (0.8) +/- .003 (0.07)	1	150	B30-R6000
i3300, i5300, BBP33	Fig. 21	B33D-1000-2-7641Y	Yellow	2/0 to 0.950 dia	0.450 (11.4) - 0.950 (24.1)	1.000 (25.4)	0.500 (12.7)	.035 (0.9) +/- .005 (0.1)	1	150	B30-R6000
i3300, i5300, BBP33	Fig. 21	B33D-1500-2-7641Y	Yellow	N/A	0.750 (19.1) - 1.400 (35.6)	1.500 (38.1)	0.752 (19.1)	.040 (1.0) +/- .006 (0.2)	1	50	B30-R6000

PermaSleeve® 2:1 Heat-Shrink Sleeves (B-7642)

- Flame retardant and high-temp rated but not as high-temp as B-345 PermaSleeve
- Meets SAE-AS23053/5 and SAE-AS-81531
- Tested per ASTM E162, ASTM E662 and MIL-STD-202

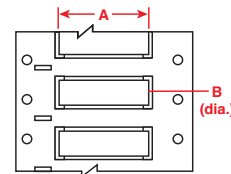

Figure 21



For Use with Printers:	Diagram	Catalog #	Color	For Wire Gauge (approx.)	For Wire Diameters Inch (mm) Min - Max.	Supplied Diameter B Inch (mm)	Recovered Diameter Inch (mm)	Recovered Wall Thickness Inch (mm)	Qty per Row	Qty per Roll	Rec. ribbon
2:1 Shrink ratio single-side printable, 2 in. sleeve width (dimension A)											
i3300, i5300, BBP33	Fig. 21	B33-94-2-7642	White	24 to 20	0.047 (1.2) - 0.080 (2.0)	0.094 (2.4)	0.047 (1.2)	.020 (0.5) +/- .003 (0.07)	1	500	B30-R4300
i3300, i5300, BBP33	Fig. 21	B33-125-2-7642	White	20 to 16	0.062 (1.6) - 0.110 (2.8)	0.125 (3.2)	0.063 (1.6)	.020 (0.5) +/- .003 (0.07)	1	500	B30-R4300
i3300, i5300, BBP33	Fig. 21	B33-187-2-7642	White	16 to 10	0.094 (2.4) - 0.151 (3.8)	0.187 (4.8)	0.094 (2.4)	.020 (0.5) +/- .003 (0.07)	1	450	B30-R4300
i3300, i5300, BBP33	Fig. 21	B33-250-2-7642	White	12 to 8	0.125 (3.2) - 0.215 (5.5)	0.250 (6.4)	0.126 (3.2)	.025 (0.6) +/- .003 (0.07)	1	400	B30-R4300
i3300, i5300, BBP33	Fig. 21	B33-375-2-7642	White	8 to 4	0.188 (4.8) - .0320 (8.1)	0.375 (9.5)	0.189 (4.8)	.025 (0.6) +/- .003 (0.07)	1	250	B30-R4300
i3300, i5300, BBP33	Fig. 21	B33-500-2-7642	White	6 to 1	0.250 (6.4) - 0.450 (11.4)	0.500 (12.7)	0.252 (6.4)	.025 (0.6) +/- .003 (0.07)	1	225	B30-R4300
i3300, i5300, BBP33	Fig. 21	B33-750-2-7642	White	2 to 4/0	0.375 (9.5) - 0.700 (17.8)	0.750 (19.1)	0.374 (9.5)	.030 (0.8) +/- .003 (0.07)	1	150	B30-R4300
i3300, i5300, BBP33	Fig. 21	B33-1000-2-7642	White	2/0 to 0.950 dia	0.450 (11.4) - 0.950 (24.1)	1.000 (25.4)	0.500 (12.7)	.035 (0.9) +/- .005 (0.1)	1	150	B30-R4300
i3300, i5300, BBP33	Fig. 21	B33-1500-2-7642	White	N/A	0.750 (19.1) - 1.400 (35.6)	1.500 (38.1)	0.752 (19.1)	.040 (1.0) +/- .006 (0.2)	1	50	B30-R4300
i3300, i5300, BBP33	Fig. 21	B33-2000-2-7642	White	N/A	1.000 (25.4) - 1.900 (48.3)	2.000 (50.8)	1.000 (25.4)	.045 (1.1) +/- .007 (0.2)	1	50	B30-R4300
2:1 Shrink ratio, Double-side printable, 2 in. sleeve width (dimension A)											
i3300, i5300, BBP33	Fig. 21	B33D-94-2-7642	White	24 to 20	0.047 (1.2) - 0.080 (2.0)	0.094 (2.4)	0.047 (1.2)	.020 (0.5) +/- .003 (0.07)	1	500	B30-R4300
i3300, i5300, BBP33	Fig. 21	B33D-125-2-7642	White	20 to 16	0.062 (1.6) - 0.110 (2.8)	0.125 (3.2)	0.063 (1.6)	.020 (0.5) +/- .003 (0.07)	1	500	B30-R4300
i3300, i5300, BBP33	Fig. 21	B33D-187-2-7642	White	16 to 10	0.094 (2.4) - 0.151 (3.8)	0.187 (4.8)	0.094 (2.4)	.020 (0.5) +/- .003 (0.07)	1	450	B30-R4300
i3300, i5300, BBP33	Fig. 21	B33D-250-2-7642	White	12 to 8	0.125 (3.2) - 0.215 (5.5)	0.250 (6.4)	0.126 (3.2)	.025 (0.6) +/- .003 (0.07)	1	400	B30-R4300
i3300, i5300, BBP33	Fig. 21	B33D-375-2-7642	White	8 to 4	0.188 (4.8) - 0.0320 (8.1)	0.375 (9.5)	0.189 (4.8)	.025 (0.6) +/- .003 (0.07)	1	250	B30-R4300
i3300, i5300, BBP33	Fig. 21	B33D-500-2-7642	White	6 to 1	0.250 (6.4) - 0.450 (11.4)	0.500 (12.7)	0.252 (6.4)	.025 (0.6) +/- .003 (0.07)	1	225	B30-R4300
i3300, i5300, BBP33	Fig. 21	B33D-750-2-7642	White	2 to 4/0	0.375 (9.5) - 0.700 (17.8)	0.750 (19.1)	0.374 (9.5)	.030 (0.8) +/- .003 (0.07)	1	150	B30-R4300
i3300, i5300, BBP33	Fig. 21	B33D-1000-2-7642	White	2/0 to 0.950 dia	0.450 (11.4) - 0.950 (24.1)	1.000 (25.4)	0.500 (12.7)	.035 (0.9) +/- .005 (0.1)	1	150	B30-R4300
i3300, i5300, BBP33	Fig. 21	B33D-1500-2-7642	White	N/A	0.750 (19.1) - 1.400 (35.6)	1.500 (38.1)	0.752 (19.1)	.040 (1.0) +/- .006 (0.2)	1	50	B30-R4300
i3300, i5300, BBP33	Fig. 21	B33D-2000-2-7642	White	N/A	1.000 (25.4) - 1.900 (48.3)	2.000 (50.8)	1.000 (25.4)	.045 (1.1) +/- .007 (0.2)	1	50	B30-R4300

QuickSleeve Handheld Sleeve Applicator

The QuickSleeve Handheld Sleeve Applicator is an intuitive multi-tool designed to help you quickly apply sleeves on to wires in three simple steps – just pick, slip and apply. This tool includes:

- Four specially designed slanted tubes sized for sleeve sizes 0.094, 0.125, 0.187 and 0.250 inches
- Built-in LED flashlight for use in low-lit conditions
- Terminal block sized screwdriver



Catalog #	Description	Qty.
QS	QuickSleeve multi-tool	1 Tool

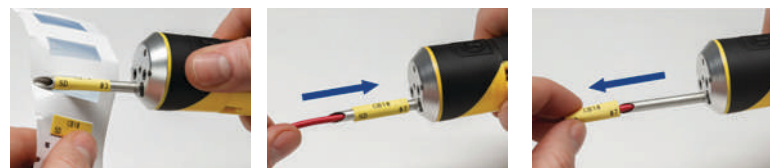

Pick

Slip

Apply

Zero-Halogen Polyurethane Cable Markers (B-7643)

- Thermoplastic polyether polyurethane is a zero-halogen high-density, thermoplastic cable marker
- The non-adhesive tag is pre-cut with 4 holes and tag is fastened to cable or wire harness bundle with cable ties
- Meets the requirements of a halogen-free material per IEC 61249-2-21 (2003-11)
- Excellent chemical, oil and water resistance

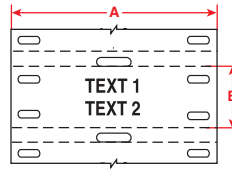

Figure 86



For Use with Printers:	Diagram	Catalog #	Color	Label width A inch (mm)	Label height B inch (mm)	Labels per row	Labels per roll	Rec. ribbon
i3300, i5300	Fig. 86	B33-60X10-7643-WT	White	2.36 (60)	0.39 (9.91)	1	1000	B30-R6000
i3300, i5300	Fig. 86	B33-75X10-7643-WT	White	2.95 (75)	0.39 (9.91)	1	750	B30-R6000
i3300, i5300	Fig. 86	B33-75X15-7643-WT	White	2.95 (75)	0.59 (14.9)	1	500	B30-R6000
i3300, i5300	Fig. 86	B33-75X25-7643-WT	White	2.95 (75)	0.98 (24.9)	1	250	B30-R6000
i3300, i5300	Fig. 86	B33-60X10-7643-YL	Yellow	2.36 (60)	0.39 (9.91)	1	1000	B30-R6000
i3300, i5300	Fig. 86	B33-75X10-7643-YL	Yellow	2.95 (75)	0.39 (9.91)	1	750	B30-R6000
i3300, i5300	Fig. 86	B33-75X15-7643-YL	Yellow	2.95 (75)	0.59 (14.9)	1	500	B30-R6000
i3300, i5300	Fig. 86	B33-75X25-7643-YL	Yellow	2.95 (75)	0.98 (24.9)	1	250	B30-R6000

Pre-Printed Pre-Cut Blank Sign Headers (B-595)

- Allows printer to create multicolor signs fast in a single print pass
- Headers meet NFPA 70E, OSHA 1910.145 and ASME / ANSI Z535 standards
- Indoor / outdoor grade material conforms to rough, highly textured and difficult-to-adhere-to surfaces

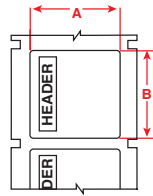

Figure 70a



Diagram	Catalog #	B#	Material	Header	Label Height A Inch (mm)	Label Width B Inch (mm)	Labels Per Row	Labels Per Roll	Rec. Ribbon
Fig. 70a	B30-241-595-OSHADADA	B-595	Vinyl		2.250 (57.5)	3.000 (76.2)	1	300	B30-R10000
Fig. 70a	B30-25-595-OSHADADA	B-595	Vinyl		4.000 (101.6)	6.000 (152.4)	1	175	B30-R10000
Fig. 70a	B30-241-595-OSHACA	B-595	Vinyl		2.250 (57.5)	3.000 (76.2)	1	300	B30-R10000
Fig. 70a	B30-25-595-OSHACA	B-595	Vinyl		4.000 (101.6)	6.000 (152.4)	1	175	B30-R10000
Fig. 70a	B30-241-595-ANSICA	B-595	Vinyl		2.250 (57.5)	3.000 (76.2)	1	300	B30-R10000
Fig. 70a	B30-25-595-ANSICA	B-595	Vinyl		4.000 (101.6)	6.000 (152.4)	1	175	B30-R10000
Fig. 70a	B30-241-595-ANSIDA	B-595	Vinyl		2.250 (57.5)	3.000 (76.2)	1	300	B30-R10000
Fig. 70a	B30-25-595-ANSIDA	B-595	Vinyl		4.000 (101.6)	6.000 (152.4)	1	175	B30-R10000
Fig. 70a	B30-241-595-ANSIWA	B-595	Vinyl		2.250 (57.5)	3.000 (76.2)	1	300	B30-R10000
Fig. 70a	B30-25-595-ANSIWA	B-595	Vinyl		4.000 (101.6)	6.000 (152.4)	1	175	B30-R10000
Fig. 70a	B30-241-595-ANSINO	B-595	Vinyl		2.250 (57.5)	3.000 (76.2)	1	300	B30-R10000
Fig. 70a	B30-25-595-ANSINO	B-595	Vinyl		4.000 (101.6)	6.000 (152.4)	1	175	B30-R10000
Fig. 70a	B30-25-595-PREC	B-595	Vinyl		4.000 (101.6)	6.000 (152.4)	1	175	B30-R10000
Fig. 70a	B30-25-595-PEL	B-595	Vinyl		4.000 (101.6)	6.000 (152.4)	1	175	B30-R10000
Fig. 70a	B30-242-595-BLNKWT	B-595	Vinyl		1.125 (28.6)	2.750 (69.9)	300	B30-R10000	B30-R10000
Fig. 70a	B30-241-595-BLNKWT	B-595	Vinyl		2.250 (57.5)	3.000 (76.2)	300	B30-R10000	B30-R10000
Fig. 70a	B30-219-595-BLNKWT	B-595	Vinyl		2.250 (57.5)	3.750 (95.3)	250	B30-R10000	B30-R10000
Fig. 70a	B30-25-595-BLNKWT	B-595	Vinyl		4.000 (101.6)	6.000 (152.4)	175	B30-R10000	B30-R10000
Fig. 70a	B30-241-595-BLNKYL	B-595	Vinyl		2.250 (57.5)	3.000 (76.2)	1	300	B30-R10000
Fig. 70a	B30-25-595-BLNKYL	B-595	Vinyl		4.000 (101.6)	6.000 (152.4)	1	175	B30-R10000

Non-Adhesive Tags (B-551)

- Non-adhesive semi-rigid card stock in pre-cut and continuous styles
- Tags are pre-cut with hole or easy to hole punch, are micro-perforated between tags to separate cleanly and some feature chamfered corners
- Snap-in plastic grommets available for extra strength around mounting hole (Catalog #20596, 100/bag)

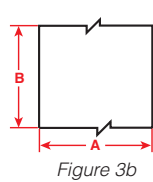

Figure 3b

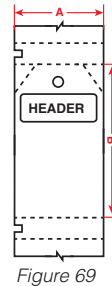

Figure 69



Diagram	Catalog #	B#	Header	Tag Width A Inch (mm)	Tag Height B Inch (mm)	Tags Per Row	Tags Per Roll	Rec. Ribbon
Fig. 69	B30-255-551-ANSIDA	B-551		3.250 (82.6)	5.750 (146.1)	1	100	B30-R10000
Fig. 69	B30-255-551-OSHADADA	B-551		3.250 (82.6)	5.750 (146.1)	1	100	B30-R10000
Fig. 69	B30-255-551-ANSICA	B-551		3.250 (82.6)	5.750 (146.1)	1	100	B30-R10000
Fig. 69	B30-255-551-WHT	B-551		3.250 (82.6)	5.750 (146.1)	1	100	B30-R10000
Fig. 3b	B30C-2500-551-WT	B-551		2.500 (63.5)	50 ft. (15.2 m)	1 roll (cont.)		B30-R10000
Fig. 3b	B30C-3250-551-WT	B-551		3.250 (82.6)	50 ft. (15.2 m)	1 roll (cont.)		B30-R10000
Fig. 3b	B30C-4250-551-WT	B-551		4.250 (107.9)	50 ft. (15.2 m)	1 roll (cont.)		B30-R10000

All part numbers above are compatible with BradyPrinter i3300 and BBP®33. Parts may also be compatible with BradyPrinter S3000, BradyPrinter S3100, BBP®30, BBP®31, BBP®35 and BBP®37 printers. Visit BradyID.com to confirm compatibility.

All-Weather Vinyl (B-595)

- For general facility and safety identification
- Durable, low-shrink vinyl with our most aggressive adhesive
- Conforms to irregular, curved, rough and highly textured surfaces (painted cinder blocks, uneven wood, textured plastics, paper-jacketed pipes, powder-coated surfaces)
- Adheres to difficult low-surface energy items (PVC piping, blow-molded equipment cases, ABS plastics, recycled plastics)

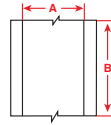
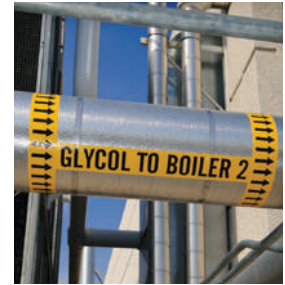

Figure 3



For Use with Printers:	Diagram	Catalog #	Color	Label Width A Inch (mm)	Roll Length B Feet (m)	Labels Per Roll	Rec. Ribbon
i3300, i5300, S3000, S3100, BBP30, BBP31, BBP33, BBP35, BBP37	Fig. 3	B30C-500-595-WT	White	0.500 (12.7)	100 (30.5)	1 roll (cont.)	B30-R10000
i3300, i5300, S3000, S3100, BBP30, BBP31, BBP33, BBP35, BBP37	Fig. 3	B30C-1125-595-WT	White	1.125 (28.6)	100 (30.5)	1 roll (cont.)	B30-R10000
i3300, i5300, S3000, S3100, BBP30, BBP31, BBP33, BBP35, BBP37	Fig. 3	B30C-2250-595-WT	White	2.250 (57.5)	100 (30.5)	1 roll (cont.)	B30-R10000
i3300, i5300, S3000, S3100, BBP30, BBP31, BBP33, BBP35, BBP37	Fig. 3	B30C-3000-595-WT	White	3.000 (76.2)	100 (30.5)	1 roll (cont.)	B30-R10000
i3300, i5300, S3000, S3100, BBP30, BBP31, BBP33, BBP35, BBP37	Fig. 3	B30C-4000-595-WT	White	4.000 (101.6)	100 (30.5)	1 roll (cont.)	B30-R10000
i3300, i5300, S3000, S3100, BBP30, BBP31, BBP33, BBP35, BBP37	Fig. 3	B30C-500-595-YL	Yellow	0.500 (12.7)	100 (30.5)	1 roll (cont.)	B30-R10000
i3300, i5300, S3000, S3100, BBP30, BBP31, BBP33, BBP35, BBP37	Fig. 3	B30C-1125-595-YL	Yellow	1.125 (28.6)	100 (30.5)	1 roll (cont.)	B30-R10000
i3300, i5300, S3000, S3100, BBP30, BBP31, BBP33, BBP35, BBP37	Fig. 3	B30C-2250-595-YL	Yellow	2.250 (57.5)	100 (30.5)	1 roll (cont.)	B30-R10000
i3300, i5300, S3000, S3100, BBP30, BBP31, BBP33, BBP35, BBP37	Fig. 3	B30C-3000-595-YL	Yellow	3.000 (76.2)	100 (30.5)	1 roll (cont.)	B30-R10000
i3300, i5300, S3000, S3100, BBP30, BBP31, BBP33, BBP35, BBP37	Fig. 3	B30C-4000-595-YL	Yellow	4.000 (101.6)	100 (30.5)	1 roll (cont.)	B30-R10000
i3300, i5300, S3000, S3100, BBP30, BBP31, BBP33, BBP35, BBP37	Fig. 3	B30C-500-595-RD	Red	0.500 (12.7)	100 (30.5)	1 roll (cont.)	B30-R10000-WT
i3300, i5300, S3000, S3100, BBP30, BBP31, BBP33, BBP35, BBP37	Fig. 3	B30C-1125-595-RD	Red	1.125 (28.6)	100 (30.5)	1 roll (cont.)	B30-R10000-WT
i3300, i5300, S3000, S3100, BBP30, BBP31, BBP33, BBP35, BBP37	Fig. 3	B30C-2250-595-RD	Red	2.250 (57.5)	100 (30.5)	1 roll (cont.)	B30-R10000-WT
i3300, i5300, S3000, S3100, BBP30, BBP31, BBP33, BBP35, BBP37	Fig. 3	B30C-4000-595-RD	Red	4.000 (101.6)	100 (30.5)	1 roll (cont.)	B30-R10000-WT
i3300, i5300, S3000, S3100, BBP30, BBP31, BBP33, BBP35, BBP37	Fig. 3	B30C-500-595-BL	Blue	0.500 (12.7)	100 (30.5)	1 roll (cont.)	B30-R10000-WT
i3300, i5300, S3000, S3100, BBP30, BBP31, BBP33, BBP35, BBP37	Fig. 3	B30C-1125-595-BL	Blue	1.125 (28.6)	100 (30.5)	1 roll (cont.)	B30-R10000-WT
i3300, i5300, S3000, S3100, BBP30, BBP31, BBP33, BBP35, BBP37	Fig. 3	B30C-2250-595-BL	Blue	2.250 (57.5)	100 (30.5)	1 roll (cont.)	B30-R10000-WT
i3300, i5300, S3000, S3100, BBP30, BBP31, BBP33, BBP35, BBP37	Fig. 3	B30C-4000-595-BL	Blue	4.000 (101.6)	100 (30.5)	1 roll (cont.)	B30-R10000-WT
i3300, i5300, S3000, S3100, BBP30, BBP31, BBP33, BBP35, BBP37	Fig. 3	B30C-500-595-GN	Green	0.500 (12.7)	100 (30.5)	1 roll (cont.)	B30-R10000-WT
i3300, i5300, S3000, S3100, BBP30, BBP31, BBP33, BBP35, BBP37	Fig. 3	B30C-1125-595-GN	Green	1.125 (28.6)	100 (30.5)	1 roll (cont.)	B30-R10000-WT
i3300, i5300, S3000, S3100, BBP30, BBP31, BBP33, BBP35, BBP37	Fig. 3	B30C-2250-595-GN	Green	2.250 (57.5)	100 (30.5)	1 roll (cont.)	B30-R10000-WT
i3300, i5300, S3000, S3100, BBP30, BBP31, BBP33, BBP35, BBP37	Fig. 3	B30C-4000-595-GN	Green	4.000 (101.6)	100 (30.5)	1 roll (cont.)	B30-R10000-WT
i3300, i5300, S3000, S3100, BBP30, BBP31, BBP33, BBP35, BBP37	Fig. 3	B30C-500-595-OR	Orange	0.500 (12.7)	100 (30.5)	1 roll (cont.)	B30-R10000
i3300, i5300, S3000, S3100, BBP30, BBP31, BBP33, BBP35, BBP37	Fig. 3	B30C-1125-595-OR	Orange	1.125 (28.6)	100 (30.5)	1 roll (cont.)	B30-R10000
i3300, i5300, S3000, S3100, BBP30, BBP31, BBP33, BBP35, BBP37	Fig. 3	B30C-2250-595-OR	Orange	2.250 (57.5)	100 (30.5)	1 roll (cont.)	B30-R10000
i3300, i5300, S3000, S3100, BBP30, BBP31, BBP33, BBP35, BBP37	Fig. 3	B30C-4000-595-OR	Orange	4.000 (101.6)	100 (30.5)	1 roll (cont.)	B30-R10000
i3300, i5300, S3000, S3100, BBP30, BBP31, BBP33, BBP35, BBP37	Fig. 3	B30C-500-595-BK	Black	0.500 (12.7)	100 (30.5)	1 roll (cont.)	B30-R10000-WT
i3300, i5300, S3000, S3100, BBP30, BBP31, BBP33, BBP35, BBP37	Fig. 3	B30C-1125-595-BK	Black	1.125 (28.6)	100 (30.5)	1 roll (cont.)	B30-R10000-WT
i3300, i5300, S3000, S3100, BBP30, BBP31, BBP33, BBP35, BBP37	Fig. 3	B30C-2250-595-BK	Black	2.250 (57.5)	100 (30.5)	1 roll (cont.)	B30-R10000-WT
i3300, i5300, S3000, S3100, BBP30, BBP31, BBP33, BBP35, BBP37	Fig. 3	B30C-4000-595-BK	Black	4.000 (101.6)	100 (30.5)	1 roll (cont.)	B30-R10000-WT
i3300, i5300, S3000, S3100, BBP30, BBP31, BBP33, BBP35, BBP37	Fig. 3	B30C-500-595-BR	Brown	0.500 (12.7)	100 (30.5)	1 roll (cont.)	B30-R10000-WT
i3300, i5300, S3000, S3100, BBP30, BBP31, BBP33, BBP35, BBP37	Fig. 3	B30C-1125-595-BR	Brown	1.125 (28.6)	100 (30.5)	1 roll (cont.)	B30-R10000-WT
i3300, i5300, S3000, S3100, BBP30, BBP31, BBP33, BBP35, BBP37	Fig. 3	B30C-2250-595-BR	Brown	2.250 (57.5)	100 (30.5)	1 roll (cont.)	B30-R10000-WT
i3300, i5300, S3000, S3100, BBP30, BBP31, BBP33, BBP35, BBP37	Fig. 3	B30C-4000-595-BR	Brown	4.000 (101.6)	100 (30.5)	1 roll (cont.)	B30-R10000-WT
i3300, i5300, S3000, S3100, BBP30, BBP31, BBP33, BBP35, BBP37	Fig. 3	B30C-500-595-GD	Gold	0.500 (12.7)	100 (30.5)	1 roll (cont.)	B30-R10000
i3300, i5300, S3000, S3100, BBP30, BBP31, BBP33, BBP35, BBP37	Fig. 3	B30C-1125-595-GD	Gold	1.125 (28.6)	100 (30.5)	1 roll (cont.)	B30-R10000
i3300, i5300, S3000, S3100, BBP30, BBP31, BBP33, BBP35, BBP37	Fig. 3	B30C-2250-595-GD	Gold	2.250 (57.5)	100 (30.5)	1 roll (cont.)	B30-R10000
i3300, i5300, S3000, S3100, BBP30, BBP31, BBP33, BBP35, BBP37	Fig. 3	B30C-4000-595-GD	Gold	4.000 (101.6)	100 (30.5)	1 roll (cont.)	B30-R10000
i3300, i5300, S3000, S3100, BBP30, BBP31, BBP33, BBP35, BBP37	Fig. 3	B30C-500-595-GY	Gray	0.500 (12.7)	100 (30.5)	1 roll (cont.)	B30-R10000
i3300, i5300, S3000, S3100, BBP30, BBP31, BBP33, BBP35, BBP37	Fig. 3	B30C-1125-595-GY	Gray	1.125 (28.6)	100 (30.5)	1 roll (cont.)	B30-R10000
i3300, i5300, S3000, S3100, BBP30, BBP31, BBP33, BBP35, BBP37	Fig. 3	B30C-2250-595-GY	Gray	2.250 (57.5)	100 (30.5)	1 roll (cont.)	B30-R10000
i3300, i5300, S3000, S3100, BBP30, BBP31, BBP33, BBP35, BBP37	Fig. 3	B30C-4000-595-GY	Gray	4.000 (101.6)	100 (30.5)	1 roll (cont.)	B30-R10000
i3300, i5300, S3000, S3100, BBP30, BBP31, BBP33, BBP35, BBP37	Fig. 3	B30C-500-595-PL	Purple	0.500 (12.7)	100 (30.5)	1 roll (cont.)	B30-R10000-WT
i3300, i5300, S3000, S3100, BBP30, BBP31, BBP33, BBP35, BBP37	Fig. 3	B30C-1125-595-PL	Purple	1.125 (28.6)	100 (30.5)	1 roll (cont.)	B30-R10000-WT
i3300, i5300, S3000, S3100, BBP30, BBP31, BBP33, BBP35, BBP37	Fig. 3	B30C-2250-595-PL	Purple	2.250 (57.5)	100 (30.5)	1 roll (cont.)	B30-R10000-WT
i3300, i5300, S3000, S3100, BBP30, BBP31, BBP33, BBP35, BBP37	Fig. 3	B30C-4000-595-PL	Purple	4.000 (101.6)	100 (30.5)	1 roll (cont.)	B30-R10000-WT
i3300, i5300, S3000, S3100, BBP30, BBP31, BBP33, BBP35, BBP37	Fig. 3	B30C-500-595-CL	Clear	0.500 (12.7)	100 (30.5)	1 roll (cont.)	B30-R10000
i3300, i5300, S3000, S3100, BBP30, BBP31, BBP33, BBP35, BBP37	Fig. 3	B30C-1125-595-CL	Clear	1.125 (28.6)	100 (30.5)	1 roll (cont.)	B30-R10000
i3300, i5300, S3000, S3100, BBP30, BBP31, BBP33, BBP35, BBP37	Fig. 3	B30C-2250-595-CL	Clear	2.250 (57.5)	100 (30.5)	1 roll (cont.)	B30-R10000
i3300, i5300, S3000, S3100, BBP30, BBP31, BBP33, BBP35, BBP37	Fig. 3	B30C-4000-595-CL	Clear	4.000 (101.6)	100 (30.5)	1 roll (cont.)	B30-R10000

U.S. Patent Nos. 5,823,689; 6,570,602. Additional Patents Pending.

ToughWash® Washdown Resistant Labels (B-854, B-855)

- Withstands high pressure, heat, harsh chemicals and numerous washdown cycles
- Legible and long-lasting for even the toughest washdown cycles
- Ideal for use in the food and beverage industry
- B-854 offers metal detectable layer to allow detection in food stream

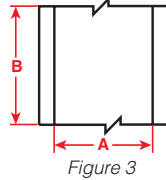

Figure 3

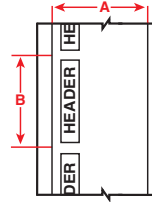

Figure 73



Diagram	Catalog #	B#	Color/ Header	Label Width A Inch (mm)	Length B Inch (mm)	Labels Per Roll	Rec. Ribbon
ToughWash Metal Detectable Material (B-854):							
Fig. 3	B30C-4000-854-YL	B-854		4.000 (101.06)	50 ft. (15.2 m)	1 roll (cont.)	B30-R6000
Fig. 3	B30C-4000-854-WT	B-854		4.000 (101.06)	50 ft. (15.2 m)	1 roll (cont.)	B30-R6000
Fig. 73	B30-25-854-OSHADA	B-854		4.000 (101.06)	6.250 (158.8)	100	B30-R6000
Fig. 73	B30-25-854-ANSIWA	B-854		4.000 (101.06)	6.250 (158.8)	100	B30-R6000
Fig. 73	B30-25-854-ANSIDA	B-854		4.000 (101.06)	6.250 (158.8)	100	B30-R6000
Fig. 73	B30-25-854-ANSICA	B-854		4.000 (101.06)	6.250 (158.8)	100	B30-R6000
Fig. 73	B30-25-854-PEL	B-854		4.000 (101.06)	6.250 (158.8)	100	B30-R6000
Fig. 73	B30-25-854-PREC	B-854		4.000 (101.06)	6.250 (158.8)	100	B30-R6000
ToughWash Material (B-855):							
Fig. 3	B30C-1125-855-YL	B-855		1.125 (28.6)	50 ft. (15.2 m)	1 roll (cont.)	B30-R6000
Fig. 3	B30C-2250-855-YL	B-855		2.250 (57.5)	50 ft. (15.2 m)	1 roll (cont.)	B30-R6000
Fig. 3	B30C-4000-855-YL	B-855		4.000 (101.06)	50 ft. (15.2 m)	1 roll (cont.)	B30-R6000
Fig. 3	B30C-1125-855-WT	B-855		1.125 (28.6)	50 ft. (15.2 m)	1 roll (cont.)	B30-R6000
Fig. 3	B30C-2250-855-WT	B-855		2.250 (57.5)	50 ft. (15.2 m)	1 roll (cont.)	B30-R6000
Fig. 3	B30C-4000-855-WT	B-855		4.000 (101.06)	50 ft. (15.2 m)	1 roll (cont.)	B30-R6000
Fig. 73	B30-25-855-OSHADA	B-855		4.000 (101.06)	6.250 (158.8)	100	B30-R6000
Fig. 73	B30-25-855-ANSIWA	B-855		4.000 (101.06)	6.250 (158.8)	100	B30-R6000
Fig. 73	B30-25-855-ANSIDA	B-855		4.000 (101.06)	6.250 (158.8)	100	B30-R6000
Fig. 73	B30-25-855-ANSICA	B-855		4.000 (101.06)	6.250 (158.8)	100	B30-R6000
Fig. 73	B30-25-855-PEL	B-855		4.000 (101.06)	6.250 (158.8)	100	B30-R6000
Fig. 73	B30-25-855-PREC	B-855		4.000 (101.06)	6.250 (158.8)	100	B30-R6000

All part numbers above are compatible with BradyPrinter i3300, i5300, S3000, S3100, and BBP30, 31, 33, 35, 37 models. Visit BradyID.com to confirm compatibility.

Chemical and Solvent Resistant Matte Polypropylene Labels (B-425A)

- Excellent solvent, fuel oil and liquids resistance
- Also has write-on ability for printed labels that require future hand-written data be added
- Flexible material conforms to irregular surfaces better than traditional polyesters
- Consult technical data sheet for UL / CSA ratings and complete performance and testing details

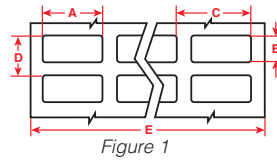

Figure 1

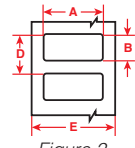

Figure 2



For Use with Printers:	Diagram	Catalog #	Color	Label width A inch (mm)	Label height B inch (mm)	Horiz. repeat C inch (mm)	Vert. repeat D inch (mm)	Web width E inch (mm)	Labels per row	Labels per roll	Rec. ribbon
i3300, i5300, BBP33	Fig. 1	B33-5-425	White	1.000 (25.4)	0.500 (12.7)	1.075 (27.3)	0.600 (15.2)	3.350 (85.1)	3	5000	B30-R4300
i3300, i5300, BBP33	Fig. 1	B33-6-425	White	1.500 (38.1)	0.750 (19.1)	1.650 (41.9)	0.875 (22.2)	3.350 (85.1)	2	3300	B30-R4300
i3300, i5300, BBP33	Fig. 2	B33-53-425	White	2.000 (50.8)	0.500 (12.7)	-	0.600 (15.2)	2.200 (55.9)	1	2000	B30-R4300
i3300, i5300, BBP33	Fig. 2	B33-17-425	White	2.000 (50.8)	1.000 (25.4)	-	1.125 (28.6)	2.200 (55.9)	1	1500	B30-R4300
i3300, i5300, BBP33	Fig. 2	B33-7-425	White	2.750 (69.9)	1.250 (31.8)	-	1.375 (34.9)	2.950 (74.9)	1	1000	B30-R4300
i3300, i5300, BBP33	Fig. 2	B33-18-425	White	3.000 (76.2)	1.000 (25.4)	-	1.125 (28.6)	3.200 (81.3)	1	1500	B30-R4300
i3300, i5300, BBP33	Fig. 2	B33-19-425	White	3.000 (76.2)	2.000 (50.8)	-	2.125 (54.0)	3.200 (81.3)	1	500	B30-R4300
i3300, i5300, BBP33	Fig. 2	B33-20-425	White	3.000 (76.2)	5.000 (127.0)	-	5.125 (130.1)	3.200 (81.3)	1	250	B30-R4300
i3300, i5300, BBP33	Fig. 2	B33-55-425	White	4.000 (101.6)	2.000 (50.8)	-	2.125 (53.9)	4.200 (106.7)	1	600	B30-R4300
i3300, i5300, BBP33	Fig. 2	B33-76-425	White	4.000 (101.6)	3.000 (76.2)	-	3.125 (79.3)	4.200 (106.7)	1	400	B30-R4300

Retro Reflective Labels (B-584)

- Highly reflective material shines back brightly when struck by light
- Ideal for labeling outdoor utility pedestals, hard hats, jobsite equipment and roof-top equipment
- Recommended for low light or inclement weather conditions

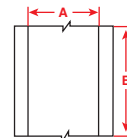

Figure 3



For Use with Printers:	Diagram	Catalog #	Color	Label Width A Inch (mm)	Roll Length B Feet (m)	Labels Per Roll	Rec. Ribbon
i3300, i5300, S3000, S3100, BBP30, BBP31, BBP33, BBP35, BBP37	Fig. 3	B30C-1125-584-SL	Silver	1.125 (28.6)	50 (15.2)	1 roll (cont.)	B30-R10000
i3300, i5300, S3000, S3100, BBP30, BBP31, BBP33, BBP35, BBP37	Fig. 3	B30C-2250-584-SL	Silver	2.250 (57.5)	50 (15.2)	1 roll (cont.)	B30-R10000
i3300, i5300, S3000, S3100, BBP30, BBP31, BBP33, BBP35, BBP37	Fig. 3	B30C-4000-584-SL	Silver	4.000 (101.6)	50 (15.2)	1 roll (cont.)	B30-R10000
i3300, i5300, S3000, S3100, BBP30, BBP31, BBP33, BBP35, BBP37	Fig. 3	B30C-1125-584-YL	Yellow	1.125 (28.6)	50 (15.2)	1 roll (cont.)	B30-R10000
i3300, i5300, S3000, S3100, BBP30, BBP31, BBP33, BBP35, BBP37	Fig. 3	B30C-2250-584-YL	Yellow	2.250 (57.5)	50 (15.2)	1 roll (cont.)	B30-R10000
i3300, i5300, S3000, S3100, BBP30, BBP31, BBP33, BBP35, BBP37	Fig. 3	B30C-4000-584-YL	Yellow	4.000 (101.6)	50 (15.2)	1 roll (cont.)	B30-R10000
i3300, i5300, S3000, S3100, BBP30, BBP31, BBP33, BBP35, BBP37	Fig. 3	B30C-1125-584-OR	Orange	1.125 (28.6)	50 (15.2)	1 roll (cont.)	B30-R10000
i3300, i5300, S3000, S3100, BBP30, BBP31, BBP33, BBP35, BBP37	Fig. 3	B30C-2250-584-OR	Orange	2.250 (57.5)	50 (15.2)	1 roll (cont.)	B30-R10000
i3300, i5300, S3000, S3100, BBP30, BBP31, BBP33, BBP35, BBP37	Fig. 3	B30C-4000-584-OR	Orange	4.000 (101.6)	50 (15.2)	1 roll (cont.)	B30-R10000

BradyGlo™ High-Intensity Glow-in-the-Dark Labels (B-526)

- For glow-in-the-dark identification up to 10 hours
- Designed for directional, evacuation and equipment marking. Ideal for marking emergency utility shut-offs, fire extinguishers, alarm pulls and vital equipment controls
- Complies with indoor use requirements specified in RS 6-1 and 6-1A of New York Local Law 26

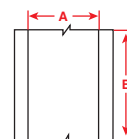

Figure 3



For Use with Printers:	Diagram	Catalog #	Color	Label Width A Inch (mm)	Roll Length B Feet (m)	Labels Per Roll	Rec. Ribbon
i3300, i5300, S3000, S3100, BBP30, BBP31, BBP33, BBP35, BBP37	Fig. 3	B30C-1125-526	Luminous Green	1.125 (28.6)	50 (15.2)	1 roll (cont.)	B30-R10000
i3300, i5300, S3000, S3100, BBP30, BBP31, BBP33, BBP35, BBP37	Fig. 3	B30C-2250-526	Luminous Green	2.250 (57.5)	50 (15.2)	1 roll (cont.)	B30-R10000
i3300, i5300, S3000, S3100, BBP30, BBP31, BBP33, BBP35, BBP37	Fig. 3	B30C-4000-526	Luminous Green	4.000 (101.6)	50 (15.2)	1 roll (cont.)	B30-R10000

Printable Magnetic Labels

(B-509)

- Easiest and quickest material for removing and repositioning
- Non-adhesive magnetic material that can be printed on directly
- Ideal for changing shelf storage locations, and reusable/repositionable Lean / 5S applications

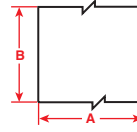

Figure 3b



For Use with Printers:	Diagram	Catalog #	Color	Label Width A Inch (mm)	Roll Length B Feet (m)	Labels Per Roll	Rec. Ribbon
i3300, i5300, S3000, S3100, BBP30, BBP31, BBP33, BBP35, BBP37	Fig. 3b	B30C-2500-509-WT	White	2.500 (63.5)	25 (7.62)	1 roll (cont.)	B30-R10000
i3300, i5300, S3000, S3100, BBP30, BBP31, BBP33, BBP35, BBP37	Fig. 3b	B30C-4250-509-WT	White	4.250 (107.8)	25 (7.62)	1 roll (cont.)	B30-R10000
i3300, i5300, S3000, S3100, BBP30, BBP31, BBP33, BBP35, BBP37	Fig. 3b	B30C-2500-509-YL	Yellow	2.500 (63.5)	25 (7.62)	1 roll (cont.)	B30-R10000
i3300, i5300, S3000, S3100, BBP30, BBP31, BBP33, BBP35, BBP37	Fig. 3b	B30C-4250-509-YL	Yellow	4.250 (107.8)	25 (7.62)	1 roll (cont.)	B30-R10000

Repositionable Multi-Purpose Vinyl

(B-581)

- Aggressive adhesive stays in place but removes cleanly without leaving adhesive residue
- Ideal for temporary, removable and repositionable facility labels, such as Lean / 5S inventory labels

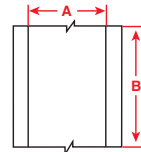

Figure 3



For Use with Printers:	Diagram	Catalog #	Color	Label Width A Inch (mm)	Roll Length B Feet (m)	Labels Per Roll	Rec. Ribbon
i3300, i5300, S3000, S3100, BBP30, BBP31, BBP33, BBP35, BBP37	Fig. 3	B30C-500-581-WT	White	0.500 (12.7)	100 (30.5)	1 roll (cont.)	B30-R10000
i3300, i5300, S3000, S3100, BBP30, BBP31, BBP33, BBP35, BBP37	Fig. 3	B30C-1125-581-WT	White	1.125 (28.6)	100 (30.5)	1 roll (cont.)	B30-R10000
i3300, i5300, S3000, S3100, BBP30, BBP31, BBP33, BBP35, BBP37	Fig. 3	B30C-2250-581-WT	White	2.250 (57.5)	100 (30.5)	1 roll (cont.)	B30-R10000
i3300, i5300, S3000, S3100, BBP30, BBP31, BBP33, BBP35, BBP37	Fig. 3	B30C-4000-581-WT	White	4.000 (101.6)	100 (30.5)	1 roll (cont.)	B30-R10000
i3300, i5300, S3000, S3100, BBP30, BBP31, BBP33, BBP35, BBP37	Fig. 3	B30C-500-581-YL	Yellow	0.500 (12.7)	100 (30.5)	1 roll (cont.)	B30-R10000
i3300, i5300, S3000, S3100, BBP30, BBP31, BBP33, BBP35, BBP37	Fig. 3	B30C-1125-581-YL	Yellow	1.125 (28.6)	100 (30.5)	1 roll (cont.)	B30-R10000
i3300, i5300, S3000, S3100, BBP30, BBP31, BBP33, BBP35, BBP37	Fig. 3	B30C-2250-581-YL	Yellow	2.250 (57.5)	100 (30.5)	1 roll (cont.)	B30-R10000
i3300, i5300, S3000, S3100, BBP30, BBP31, BBP33, BBP35, BBP37	Fig. 3	B30C-4000-581-YL	Yellow	4.000 (101.6)	100 (30.5)	1 roll (cont.)	B30-R10000

Cold Temperature Application Labels

(B-549)

- Special adhesive permanently adheres to extremely cold surfaces
- Can be applied in -10° F and lasts in -40° F
- Ideal for cold storage warehouses, coolers, freezers and short-term winter outdoor use

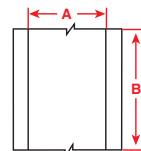

Figure 3



For Use with Printers:	Diagram	Catalog #	Color	Label Width A Inch (mm)	Roll Length B Feet (m)	Labels Per Roll	Rec. Ribbon
i3300, i5300, S3000, S3100, BBP30, BBP31, BBP33, BBP35, BBP37	Fig. 3	B30C-1125-549-WT	White	1.125 (28.6)	100 (30.5)	1 roll (cont.)	B30-R10000
i3300, i5300, S3000, S3100, BBP30, BBP31, BBP33, BBP35, BBP37	Fig. 3	B30C-2250-549-WT	White	2.250 (57.5)	100 (30.5)	1 roll (cont.)	B30-R10000
i3300, i5300, S3000, S3100, BBP30, BBP31, BBP33, BBP35, BBP37	Fig. 3	B30C-4000-549-WT	White	4.000 (101.6)	100 (30.5)	1 roll (cont.)	B30-R10000
i3300, i5300, S3000, S3100, BBP30, BBP31, BBP33, BBP35, BBP37	Fig. 3	B30C-1125-549-YL	Yellow	1.125 (28.6)	100 (30.5)	1 roll (cont.)	B30-R10000
i3300, i5300, S3000, S3100, BBP30, BBP31, BBP33, BBP35, BBP37	Fig. 3	B30C-2250-549-YL	Yellow	2.250 (57.5)	100 (30.5)	1 roll (cont.)	B30-R10000
i3300, i5300, S3000, S3100, BBP30, BBP31, BBP33, BBP35, BBP37	Fig. 3	B30C-4000-549-YL	Yellow	4.000 (101.6)	100 (30.5)	1 roll (cont.)	B30-R10000

Pre-Printed GHS / CLP Chemical Labels (B-569, B-7569)

- Blank labels with pre-printed red diamonds allow the printer to produce 2-color GHS / CLP labels in one print pass
- Three sizes of labels, each with six diamond layouts that match templates in the printer app (if applicable) or in the Brady Workstation GHS App
- Indoor / outdoor vinyl material and durable inks withstand exposure to moisture, chemicals and handling



Catalog #	B#	Material	Legend		Label Height Inch (mm)	Label Width Inch (mm)	Labels Per Row	Labels Per Roll	Rec. Ribbon
B30-260-7569-CLP1	B-7569	Vinyl		L1 Diamond + Text	2.170 (55.0)	3.350 (85.1)	1	340	B30-R10000
B30-261-7569-CLP1	B-7569	Vinyl		L1 Diamond + Text	2.950 (75.0)	4.330 (110.0)	1	270	B30-R10000
B30-262-7569-CLP1	B-7569	Vinyl		L1 Diamond + Text	4.130 (105.0)	6.100 (155.0)	1	200	B30-R10000
B30-260-7569-CLP2	B-7569	Vinyl		L2 Diamond + Text	2.170 (55.0)	3.350 (85.1)	1	340	B30-R10000
B30-261-7569-CLP2	B-7569	Vinyl		L2 Diamond + Text	2.950 (75.0)	4.330 (110.0)	1	270	B30-R10000
B30-262-7569-CLP2	B-7569	Vinyl		L2 Diamond + Text	4.130 (105.0)	6.100 (155.0)	1	200	B30-R10000
B30-260-7569-CLP3A	B-7569	Vinyl		L3A Diamond + Text	2.170 (55.0)	3.350 (85.1)	1	340	B30-R10000
B30-261-7569-CLP3A	B-7569	Vinyl		L3A Diamond + Text	2.950 (75.0)	4.330 (110.0)	1	270	B30-R10000
B30-262-7569-CLP3A	B-7569	Vinyl		L3A Diamond + Text	4.130 (105.0)	6.100 (155.0)	1	200	B30-R10000
B30-260-7569-CLP3B	B-7569	Vinyl		L3B Diamond + Text	2.170 (55.0)	3.350 (85.1)	1	340	B30-R10000
B30-261-7569-CLP3B	B-7569	Vinyl		L3B Diamond + Text	2.950 (75.0)	4.330 (110.0)	1	270	B30-R10000
B30-262-7569-CLP3B	B-7569	Vinyl		L3B Diamond + Text	4.130 (105.0)	6.100 (155.0)	1	200	B30-R10000
B30-260-7569-CLP4A	B-7569	Vinyl		L4A Diamond + Text	2.170 (55.0)	3.350 (85.1)	1	340	B30-R10000
B30-261-7569-CLP4A	B-7569	Vinyl		L4A Diamond + Text	2.950 (75.0)	4.330 (110.0)	1	270	B30-R10000
B30-262-7569-CLP4A	B-7569	Vinyl		L4A Diamond + Text	4.130 (105.0)	6.100 (155.0)	1	200	B30-R10000
B30-260-569-CLP4B	B-569	Polyester		L4B Diamond + Text	2.170 (55.0)	3.350 (85.1)	1	340	B30-R10000
B30-260-7569-CLP4B	B-7569	Vinyl		L4B Diamond + Text	2.170 (55.0)	3.350 (85.1)	1	340	B30-R10000
B30-261-569-CLP4B	B-569	Polyester		L4B Diamond + Text	2.950 (75.0)	4.330 (110.0)	1	270	B30-R10000
B30-261-7569-CLP4B	B-7569	Vinyl		L4B Diamond + Text	2.950 (75.0)	4.330 (110.0)	1	270	B30-R10000
B30-262-569-CLP4B	B-569	Polyester		L4B Diamond + Text	4.130 (105.0)	6.100 (155.0)	1	200	B30-R10000
B30-262-7569-CLP4B	B-7569	Vinyl		L4B Diamond + Text	4.130 (105.0)	6.100 (155.0)	1	200	B30-R10000
B30-18-7569-CLP4C	B-7569	Vinyl		L4C Diamond + Text	1.000 (25.4)	3.000 (76.2)	1	1000	B30-R10000

▶ Easily create your GHS labels with Brady Workstation GHS App

- Use built-in pre-formatted label layouts with approved GHS symbols
- Search the built-in chemical database by CAS number to auto-populate your label, then edit to meet your specific SDS
- Print any of the six template sizes
- No driver required when using the BradyPrinter i5300



All part numbers above are compatible with BradyPrinter i3300, i5300, S3000, S3100, and BBP30, 31, 33, 35, 37 models. Visit BradyID.com to confirm compatibility.

General Identification Die Cut Labels for Bins, Shelves, Tools and Production Areas

(B-439, B-498, B-499, B-595)

- These labels are all highly conforming to irregular, angled or rough surfaces frequently found in industrial production line areas
- Die-cut labels are an ideal choice when pre-cut labels are preferred or consistent label sizing is required
- B-595 is a convenient cut-to-length continuous material that reduces the need to stock multiple parts when inconsistent label lengths are expected

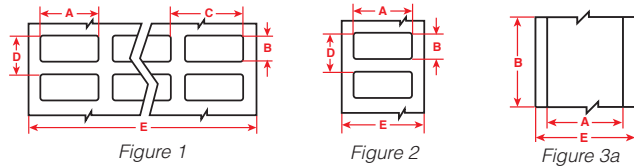

For Use with Printers:	Diagram	Catalog #	Color	Label width A inch (mm)	Label height B inch (mm)	Horiz. repeat C inch (mm)	Vert. repeat D inch (mm)	Web width E inch (mm)	Labels per row	Labels per roll	Rec. ribbon
Vinyl - Highly pliable and conforming with aggressive permanent adhesive and excellent chemical resistance (B-439)											
i3300, i5300, BBP33	Fig. 1	B33-5-439	White	1.000 (25.4)	0.500 (12.7)	1.075 (27.3)	0.600 (15.2)	3.350 (85.1)	3	7000	B30-R6000
i3300, i5300, BBP33	Fig. 1	B33-37-439	White	1.500 (38.1)	0.500 (12.7)	1.650 (41.9)	0.600 (15.2)	3.350 (85.1)	2	5000	B30-R6000
i3300, i5300, BBP33	Fig. 2	B33-53-439	White	2.000 (50.8)	0.500 (12.7)	-	0.600 (15.2)	2.200 (55.9)	1	2500	B30-R6000
i3300, i5300, BBP33	Fig. 2	B33-17-439	White	2.000 (50.8)	1.000 (25.4)	-	1.125 (28.5)	2.200 (55.9)	1	1000	B30-R6000
i3300, i5300, BBP33	Fig. 2	B33-18-439	White	3.000 (76.2)	1.000 (25.4)	-	1.125 (28.5)	3.350 (85.1)	1	1000	B30-R6000
i3300, i5300, BBP33	Fig. 2	B33-19-439	White	3.000 (76.2)	2.000 (50.8)	-	2.125 (53.9)	3.200 (81.3)	1	700	B30-R6000
i3300, i5300, BBP33	Fig. 2	B33-55-439	White	4.000 (101.6)	2.000 (50.8)	-	2.125 (53.9)	4.200 (106.7)	1	700	B30-R6000
i3300, i5300, BBP33	Fig. 2	B33-76-439	White	4.000 (101.6)	3.000 (76.2)	-	3.125 (79.3)	4.200 (106.7)	1	500	B30-R6000
Flexible Vinyl Cloth - Pliable with aggressive hold adhesive that can be removed and reapplied (B-498)											
i3300, i5300, BBP33	Fig. 1	B33-68-498	White	0.500 (12.7)	0.750 (19.1)	0.600 (15.2)	0.875 (22.2)	2.500 (63.5)	4	5000	B30-R6200
i3300, i5300, BBP33	Fig. 1	B33-87-498	White	0.500 (12.7)	1.437 (36.5)	0.600 (15.2)	1.562 (39.7)	3.700 (94.0)	6	2500	B30-R6200
i3300, i5300, BBP33	Fig. 1	B33-5-498	White	1.000 (25.4)	0.500 (12.7)	1.075 (27.3)	0.600 (15.2)	3.350 (85.1)	3	5000	B30-R6200
i3300, i5300, BBP33	Fig. 1	B33-88-498	White	1.000 (25.4)	0.750 (19.1)	1.100 (27.9)	0.875 (22.2)	2.300 (58.4)	2	2500	B30-R6200
i3300, i5300, BBP33	Fig. 1	B33-89-498	White	1.000 (25.4)	1.437 (36.5)	1.100 (27.9)	1.562 (39.7)	3.400 (86.4)	3	2300	B30-R6200
Flexible Nylon Cloth - Permanent adhesive (B-499)											
i3300, i5300, BBP33	Fig. 1	B33-68-499	White	0.500 (12.7)	0.750 (19.1)	0.600 (15.2)	0.875 (22.2)	2.500 (63.5)	4	1500	B30-R6000
i3300, i5300, BBP33	Fig. 1	B33-165-499	White	0.800 (20.3)	1.437 (36.5)	0.900 (22.9)	1.562 (39.7)	3.700 (94.0)	4	2500	B30-R6000
i3300, i5300, BBP33	Fig. 1	B33-5-499	White	1.000 (25.4)	0.500 (12.7)	1.075 (27.3)	0.600 (15.2)	3.350 (85.1)	3	5000	B30-R6000
i3300, i5300, BBP33	Fig. 1	B33-88-499	White	1.000 (25.4)	0.750 (19.1)	1.100 (27.9)	0.875 (22.2)	2.300 (58.4)	2	2500	B30-R6000
i3300, i5300, BBP33	Fig. 2	B33-136-499	White	1.500 (38.1)	0.750 (19.1)	-	0.875 (22.2)	1.770 (45.0)	1	1500	B30-R6000
i3300, i5300, BBP33	Fig. 2	B33-137-499	White	2.000 (50.8)	1.000 (25.4)	-	1.125 (28.6)	2.200 (55.9)	1	1100	B30-R6000
Glossy Polyester - Ultra-aggressive adhesive for flat but highly textured surfaces (B-483)											
i3300, i5300, BBP33	Fig. 1	B33-149-483	Gloss White	0.500 (12.7)	0.500 (12.7)	0.600 (15.2)	0.600 (15.2)	2.500 (63.5)	4	5000	B30-R6000
i3300, i5300, BBP33	Fig. 1	B33-5-483	Gloss White	1.000 (25.4)	0.500 (12.7)	1.075 (27.3)	0.600 (15.2)	3.350 (85.1)	3	5000	B30-R6000
i3300, i5300, BBP33	Fig. 2	B33-17-483	Gloss White	2.000 (50.8)	1.000 (25.4)	-	1.125 (28.6)	2.200 (55.9)	1	1500	B30-R6000
i3300, i5300, BBP33	Fig. 2	B33-7-483	Gloss White	2.750 (69.9)	1.250 (31.8)	-	1.375 (34.9)	2.950 (74.9)	1	1000	B30-R6000
i3300, i5300, BBP33	Fig. 2	B33-18-483	Gloss White	3.000 (76.2)	1.000 (25.4)	-	1.125 (28.6)	3.200 (81.3)	1	1500	B30-R6000
i3300, i5300, BBP33	Fig. 2	B33-19-483	Gloss White	3.000 (76.2)	2.000 (50.8)	-	2.125 (54.0)	3.200 (81.3)	1	500	B30-R6000
i3300, i5300, BBP33	Fig. 2	B33-55-483	Gloss White	4.000 (101.6)	2.000 (50.8)	-	2.125 (54.0)	4.200 (106.7)	1	750	B30-R6000
Cut-to-Length Vinyl - Highly pliable all weather with aggressive permanent adhesive (B-595)											
i3300, i5300, S3000, S3100, BBP30, BBP31, BBP33, BBP35, BBP37	Fig. 3a	B30C-500-595-WT	White	0.500 (12.7)	100 ft. (30.5 m)	-	-	0.700 (17.8)	1 roll (cont.)		B30-R10000
i3300, i5300, S3000, S3100, BBP30, BBP31, BBP33, BBP35, BBP37	Fig. 3a	B30C-1125-595-WT	White	1.125 (28.6)	100 ft. (30.5 m)	-	-	1.375 (34.9)	1 roll (cont.)		B30-R10000
i3300, i5300, S3000, S3100, BBP30, BBP31, BBP33, BBP35, BBP37	Fig. 3a	B30C-500-595-YL	Yellow	0.500 (12.7)	100 ft. (30.5 m)	-	-	0.700 (17.8)	1 roll (cont.)		B30-R10000
i3300, i5300, S3000, S3100, BBP30, BBP31, BBP33, BBP35, BBP37	Fig. 3a	B30C-1125-595-YL	Yellow	1.125 (28.6)	100 ft. (30.5 m)	-	-	1.375 (34.9)	1 roll (cont.)		B30-R10000

ToughStripe® Printable Floor Marking Tape (B-483A with overlamine)

- Revolutionary B-483A material has ultra-aggressive adhesive
- Withstands forklift and pallet jack traffic without tearing or lifting
- Each roll ships with a roll of clear overlamine which must be applied over printed label and onto appropriate surface for best performance

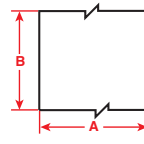

Figure 3b



Diagram	Catalog #	B#	Color	Label Width A Inch (mm)	Roll Length B Feet (m)	Labels Per Roll	Rec. Ribbon
Fig. 3b	B30C-1125-483WT-KT	B-483	White	1.125 (28.6)	100 (30.5)	1 roll (cont.)	B30-R6000
Fig. 3b	B30C-2250-483WT-KT	B-483	White	2.250 (57.5)	100 (30.5)	1 roll (cont.)	B30-R6000
Fig. 3b	B30C-3000-483WT-KT	B-483	White	3.000 (76.2)	100 (30.5)	1 roll (cont.)	B30-R6000
Fig. 3b	B30C-4000-483WT-KT	B-483	White	4.000 (101.6)	100 (30.5)	1 roll (cont.)	B30-R6000
Fig. 3b	B30C-1125-483YL-KT	B-483	Yellow	1.125 (28.6)	100 (30.5)	1 roll (cont.)	B30-R6000
Fig. 3b	B30C-2250-483YL-KT	B-483	Yellow	2.250 (57.5)	100 (30.5)	1 roll (cont.)	B30-R6000
Fig. 3b	B30C-3000-483YL-KT	B-483	Yellow	3.000 (76.2)	100 (30.5)	1 roll (cont.)	B30-R6000
Fig. 3b	B30C-4000-483YL-KT	B-483	Yellow	4.000 (101.6)	100 (30.5)	1 roll (cont.)	B30-R6000
Fig. 3b	B30C-1125-483RD-KT	B-483	Red	1.125 (28.6)	100 (30.5)	1 roll (cont.)	B30-R4400-WT
Fig. 3b	B30C-2250-483RD-KT	B-483	Red	2.250 (57.5)	100 (30.5)	1 roll (cont.)	B30-R4400-WT
Fig. 3b	B30C-4000-483RD-KT	B-483	Red	4.000 (101.6)	100 (30.5)	1 roll (cont.)	B30-R4400-WT
Fig. 3b	B30C-1125-483BL-KT	B-483	Blue	1.125 (28.6)	100 (30.5)	1 roll (cont.)	B30-R4400-WT
Fig. 3b	B30C-2250-483BL-KT	B-483	Blue	2.250 (57.5)	100 (30.5)	1 roll (cont.)	B30-R4400-WT
Fig. 3b	B30C-4000-483BL-KT	B-483	Blue	4.000 (101.6)	100 (30.5)	1 roll (cont.)	B30-R4400-WT
Fig. 3b	B30C-1125-483GN-KT	B-483	Green	1.125 (28.6)	100 (30.5)	1 roll (cont.)	B30-R4400-WT
Fig. 3b	B30C-2250-483GN-KT	B-483	Green	2.250 (57.5)	100 (30.5)	1 roll (cont.)	B30-R4400-WT
Fig. 3b	B30C-4000-483GN-KT	B-483	Green	4.000 (101.6)	100 (30.5)	1 roll (cont.)	B30-R4400-WT
Fig. 3b	B30C-1125-483BK-KT	B-483	Black	1.125 (28.6)	100 (30.5)	1 roll (cont.)	B30-R4400-WT
Fig. 3b	B30C-2250-483BK-KT	B-483	Black	2.250 (57.5)	100 (30.5)	1 roll (cont.)	B30-R4400-WT
Fig. 3b	B30C-4000-483BK-KT	B-483	Black	4.000 (101.6)	100 (30.5)	1 roll (cont.)	B30-R4400-WT
Fig. 3b	B30C-1125-483OR-KT	B-483	Orange	1.125 (28.6)	100 (30.5)	1 roll (cont.)	B30-R6000
Fig. 3b	B30C-2250-483OR-KT	B-483	Orange	2.250 (57.5)	100 (30.5)	1 roll (cont.)	B30-R6000
Fig. 3b	B30C-4000-483OR-KT	B-483	Orange	4.000 (101.6)	100 (30.5)	1 roll (cont.)	B30-R6000

ToughStripe part numbers above are compatible with BradyPrinter i3300, i5300, BradyPrinter S3000, BradyPrinter S3100, and BBP®35 and BBP®37 printers. **ToughStripe material is not compatible with BBP®30, BBP®33 and BBP®31 printers.**

Microscope Slide Labels (B-481)

- Designed specifically to identify slides and to resist exposure to harsh chemicals during the slide-staining process
- Performs well in stains such as hematoxylin and eosin
- Extreme chemical resistance withstands the rigors of typical deparaffinization, including ethanol, xylene and H&E staining processes

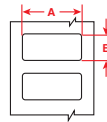

Figure 2

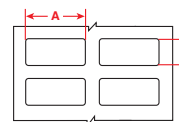

Figure 25



For Use with Printers:	Diagram	Catalog #	B#	Color	Label Width A Inch (mm)	Label Height B Inch (mm)	Labels Per Row	Labels Per Roll	Rec. Ribbon
i3300, i5300, BBP33	Fig. 2	B33-194-481	B-481	White	0.900 (22.9)	0.750 (19.1)	1	2000	B30-R6400
i3300, i5300, BBP33	Fig. 25	B33-141-481	B-481	White	0.900 (22.9)	0.900 (22.9)	2	1500	B30-R6400
i3300, i5300, BBP33	Fig. 2	B33-195-481	B-481	White	0.900 (22.9)	0.375 (9.5)	1	3000	B30-R6400

Cryogenic Tube and Vial Labels (B-461, B-490, B-492, B-7425)

FreezerBondz™ labels can be applied to room temperature or already frozen samples, with a small overlap. The label remains legible and will stick to the tube during processing, even when immersed in liquid or vapor phase nitrogen and ultra-low temperature freezer storage.

- **B-461 Self-Laminating Polyester:** Ultra-thin polyester label with clear overlaminated tail that protects print and allows liquid levels to be visible
- **B-490 Polyester:** White FreezerBondz label ideal for flat frozen surfaces. Adheres to frozen tubes and vials when wrapped around itself by at least 1/8 in.
- **B-492 Polyester:** FreezerBondz ultra-thin white polyester label for labeling of frosted/frozen or room temperature vials, tubes and canes. Superior chemical and abrasion resistance
- **B-7425 Polypropylene:** Ideal for labeling dry, room temperature specimen containers. Material withstands temperature ranges from -320° to 248° F (-196° to 121° C). Chemical resistance to ethanol, DMSO, IPS, short-term xylene, 10% formalin, 50% acetic acid and toluene

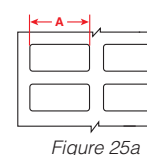
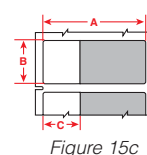
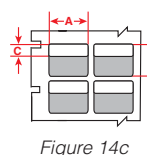
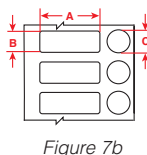
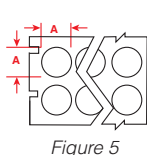
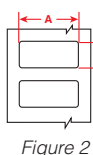

For Use with Printers:	Diagram	Catalog #	B#	Color	Label Width A Inch (mm)	Label Height B Inch (mm)	Print-On Height C Inch (mm)	Labels Per Row	Labels Per Roll	Rec. Ribbon
Self-Laminating Polyester (B-461):										
i3300, i5300, BBP33	Fig. 15c	B33-127-461	B-461	White/Clear	0.500 (12.7)	2.200 (55.9)	0.750 (19.1)	1	1500	B30-R4300
i3300, i5300, BBP33	Fig. 15c	B33-133-461	B-461	White/Clear	0.600 (15.2)	1.625 (41.3)	1.000 (25.4)	1	1500	B30-R4300
i3300, i5300, BBP33	Fig. 14c	B33-139-461	B-461	White/Clear	1.000 (25.4)	5.250 (133.4)	1.500 (38.1)	2	650	B30-R4300
i3300, i5300, BBP33	Fig. 15c	B33-123-461	B-461	White/Clear	1.800 (45.7)	0.375 (9.5)	0.750 (19.1)	1	1500	B30-R4300
i3300, i5300, BBP33	Fig. 15c	B33-122-461	B-461	White/Clear	1.800 (45.7)	0.500 (12.7)	0.750 (19.1)	1	1500	B30-R4300
i3300, i5300, BBP33	Fig. 14c	B33-276-461	B-461	White/Clear	2.625 (66.7)	1.000 (25.4)	1.000 (25.4)	1	1500	B30-R4300
i3300, i5300, BBP33	Fig. 15c	B33-134-461	B-461	White/Clear	3.500 (88.9)	1.500 (38.1)	1.250 (31.8)	1	1000	B30-R4300
Polyester (B-490):										
i3300, i5300, BBP33	Fig. 7b	B33-126-490	B-490	White	0.900 (22.9)	0.500 (12.7)	0.500 (12.7) dia.	1	2500	B30-R4300
i3300, i5300, BBP33	Fig. 2	B33-154-490	B-490	White	1.250 (31.8)	0.375 (9.5)	-	1	1500	B30-R4300
i3300, i5300, BBP33	Fig. 2	B33-155-490	B-490	White	1.625 (41.3)	0.600 (15.2)	-	1	1500	B30-R4300
i3300, i5300, BBP33	Fig. 2	B33-156-490	B-490	White	1.900 (48.2)	1.000 (25.4)	-	1	1500	B30-R4300
i3300, i5300, BBP33	Fig. 2	B33-157-490	B-490	White	2.200 (55.9)	1.500 (38.1)	-	1	1000	B30-R4300
i3300, i5300, BBP33	Fig. 2	B33-158-490	B-490	White	3.750 (95.3)	1.750 (44.4)	-	1	1100	B30-R4300
Polyester (B-492):										
i3300, i5300, BBP33	Fig. 5	B33-143-492	B-492	White	0.375 (9.5) dia.	-	-	4	1500	B30-R6400
i3300, i5300, BBP33	Fig. 7b	B33-182-492	B-492	White	0.500 (12.7)	1.000 (25.4)	0.44 (11.17) dia.	1	1500	B30-R6400
i3300, i5300, BBP33	Fig. 2	B33-180-492	B-492	White	0.900 (22.9)	1.000 (25.4)	-	1	1500	B30-R6400
i3300, i5300, BBP33	Fig. 25a	B33-152-492	B-492	White	1.000 (25.4)	0.375 (9.5)	-	2	2500	B30-R6400
i3300, i5300, BBP33	Fig. 7b	B33-163-492	B-492	White	1.000 (25.4)	0.375 (9.5)	0.375 (9.5) dia.	1	1500 sets	B30-R6400
i3300, i5300, BBP33	Fig. 7b	B33-181-492	B-492	White	1.000 (25.4)	0.500 (12.7)	0.375 (9.5) dia.	1	1500 sets	B30-R6400
i3300, i5300, BBP33	Fig. 2	B33-59-492	B-492	White	1.000 (25.4)	0.500 (12.7)	-	1	2500	B30-R6400
i3300, i5300, BBP33	Fig. 2	B33-179-492	B-492	White	1.000 (25.4)	1.000 (25.4)	-	1	1900	B30-R6400
i3300, i5300, BBP33	Fig. 2	B33-156-492	B-492	White	1.900 (48.3)	1.000 (25.4)	-	1	1500	B30-R6400
Polypropylene (B-7425):										
i3300, i5300, BBP33	Fig. 2	B33-257-7425	B-7425	White	0.825 (21.0)	0.250 (6.4)	-	1	1500	B30-R4300
i3300, i5300, BBP33	Fig. 25a	B33-152-7425	B-7425	White	1.000 (25.4)	0.375 (9.5)	-	2	2000	B30-R4300
i3300, i5300, BBP33	Fig. 2	B33-59-7425	B-7425	White	1.000 (25.4)	0.500 (12.7)	-	1	2000	B30-R4300
i3300, i5300, BBP33	Fig. 25a	B33-88-7425	B-7425	White	1.000 (25.4)	0.750 (19.1)	-	2	2000	B30-R4300
i3300, i5300, BBP33	Fig. 2	B33-256-7425	B-7425	White	1.300 (33.0)	0.600 (15.2)	-	1	1500	B30-R4300
i3300, i5300, BBP33	Fig. 25a	B33-37-7425	B-7425	White	1.500 (38.1)	0.500 (12.7)	-	2	1500	B30-R4300

Centrifuge and PCR Tube Labels (B-499, B-7425)

Designed with ultra-thin material that prevents vials from jamming in centrifuges or racks, these labels withstand harsh temperatures and chemicals without falling off, fading or smearing.

- **B-499 Nylon Cloth:** Thick white nylon cloth for easy handling and conformability
- **B-7425 Polypropylene:** Moderate chemical resistance, ideal for labeling dry, room-temperature specimen containers that withstand temperature ranges from -320° to 248° F (-196° to 121° C). Chemical resistance to ethanol, DMSO, IPS, short-term xylene, 10% formalin, 50% acetic acid and toluene

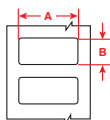

Figure 2

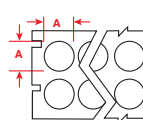

Figure 5

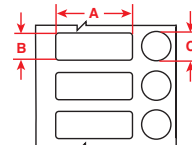

Figure 7b



For Use with Printers:	Diagram	Catalog #	B#	Color	Label Width A Inch (mm)	Label Height B Inch (mm)	Vial Top Dia. C Inch (mm)	Labels Per Row	Labels Per Roll	Rec. Ribbon
Nylon Cloth (B-499):										
i3300, i5300, BBP33	Fig. 5	B33-143-499	B-499	White	0.375 (9.5)	-	-	4	1500	B30-R6000
i3300, i5300, BBP33	Fig. 5	B33-144-499	B-499	White	0.500 (12.7)	-	-	3	1500	B30-R6000
Polypropylene (B-7425):										
i3300, i5300, BBP33	Fig. 2	B33-257-7425	B-7425	White	0.825 (21.0)	0.250 (6.4)	-	1	1500	B30-R4300
i3300, i5300, BBP33	Fig. 2	B33-152-7425	B-7425	White	1.000 (25.4)	0.375 (9.5)	-	2	2000	B30-R4300
i3300, i5300, BBP33	Fig. 7b	B33-249-7425	B-7425	White	1.000 (25.4)	0.375 (9.5)	0.375 (9.5) dia.	1	1500	B30-R4300
i3300, i5300, BBP33	Fig. 2	B33-59-7425	B-7425	White	1.000 (25.4)	0.500 (12.7)	-	1	2000	B30-R4300
i3300, i5300, BBP33	Fig. 7b	B33-251-7425	B-7425	White	1.000 (25.4)	0.500 (12.7)	0.440 (11.1) dia.	1	1500	B30-R4300
i3300, i5300, BBP33	Fig. 2	B33-179-7425	B-7425	White	1.000 (25.4)	1.000 (25.4)	-	1	1500	B30-R4300
i3300, i5300, BBP33	Fig. 2	B33-256-7425	B-7425	White	1.300 (33.0)	0.600 (15.2)	-	1	1500	B30-R4300
i3300, i5300, BBP33	Fig. 2	B33-37-7425	B-7425	White	1.500 (38.1)	0.500 (12.7)	-	2	1500	B30-R4300
i3300, i5300, BBP33	Fig. 2	B33-136-7425	B-7425	White	1.500 (38.1)	0.750 (19.1)	-	1	1500	B30-R4300
i3300, i5300, BBP33	Fig. 2	B33-258-7425	B-7425	White	1.500 (38.1)	1.750 (44.5)	-	1	900	B30-R4300
i3300, i5300, BBP33	Fig. 2	B33-137-7425	B-7425	White	2.000 (50.8)	1.000 (25.4)	-	1	1500	B30-R4300

Color-Stripe Polyester Lab Labels (B-494)

White labels with preprinted color borders for color-coding samples. Ultra-thin material that prevents vials from jamming in centrifuges or racks, these labels withstand harsh temperatures and chemicals without falling off, fading or smearing. The colored border is non-printable, but the colored vial top is printable.

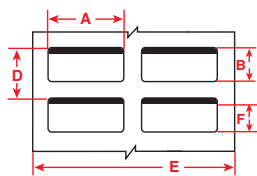

Figure 25c

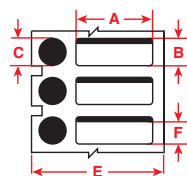

Figure 24b

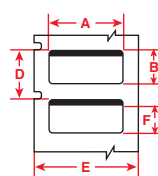

Figure 2e



For Use with Printers:	Diagram	Catalog #	Border Color	Label width A inch (mm)	Label height B inch (mm)	Print-On Height C inch (mm)	Print-On Height F inch (mm)	Labels per row	Labels per roll	Rec. ribbon
i3300, i5300, BBP33	Fig. 25c	B33-152-494-BL	Blue	1.000 (25.4)	0.375 (9.5)	-	0.250 (6.4)	2	1,500	B30-R6400
i3300, i5300, BBP33	Fig. 25c	B33-152-494-GN	Green	1.000 (25.4)	0.375 (9.5)	-	0.250 (6.4)	2	1,500	B30-R6400
i3300, i5300, BBP33	Fig. 25c	B33-152-494-OR	Orange	1.000 (25.4)	0.375 (9.5)	-	0.250 (6.4)	2	1,500	B30-R6400
i3300, i5300, BBP33	Fig. 25c	B33-152-494-PK	Pink	1.000 (25.4)	0.375 (9.5)	-	0.250 (6.4)	2	1,500	B30-R6400
i3300, i5300, BBP33	Fig. 25c	B33-152-494-RD	Red	1.000 (25.4)	0.375 (9.5)	-	0.250 (6.4)	2	1,500	B30-R6400
i3300, i5300, BBP33	Fig. 25c	B33-152-494-YL	Yellow	1.000 (25.4)	0.375 (9.5)	-	0.250 (6.4)	2	1,500	B30-R6400
i3300, i5300, BBP33	Fig. 24b	B33-250-494-BL	Blue	1.000 (25.4)	0.500 (12.7)	0.375 (9.5) dia.	0.375 (9.5)	1	1,500	B30-R6400
i3300, i5300, BBP33	Fig. 24b	B33-250-494-GN	Green	1.000 (25.4)	0.500 (12.7)	0.375 (9.5) dia.	0.375 (9.5)	1	1,500	B30-R6400
i3300, i5300, BBP33	Fig. 24b	B33-250-494-OR	Orange	1.000 (25.4)	0.500 (12.7)	0.375 (9.5) dia.	0.375 (9.5)	1	1,500	B30-R6400
i3300, i5300, BBP33	Fig. 24b	B33-250-494-PK	Pink	1.000 (25.4)	0.500 (12.7)	0.375 (9.5) dia.	0.375 (9.5)	1	1,500	B30-R6400
i3300, i5300, BBP33	Fig. 24b	B33-250-494-RD	Red	1.000 (25.4)	0.500 (12.7)	0.375 (9.5) dia.	0.375 (9.5)	1	1,500	B30-R6400
i3300, i5300, BBP33	Fig. 24b	B33-250-494-YL	Yellow	1.000 (25.4)	0.500 (12.7)	0.375 (9.5) dia.	0.375 (9.5)	1	1,500	B30-R6400
i3300, i5300, BBP33	Fig. 2e	B33-179-494-BL	Blue	1.000 (25.4)	1.000 (25.4)	-	0.875 (22.2)	1	1,500	B30-R6400
i3300, i5300, BBP33	Fig. 2e	B33-179-494-GN	Green	1.000 (25.4)	1.000 (25.4)	-	0.875 (22.2)	1	1,500	B30-R6400
i3300, i5300, BBP33	Fig. 2e	B33-179-494-OR	Orange	1.000 (25.4)	1.000 (25.4)	-	0.875 (22.2)	1	1,500	B30-R6400
i3300, i5300, BBP33	Fig. 2e	B33-179-494-PK	Pink	1.000 (25.4)	1.000 (25.4)	-	0.875 (22.2)	1	1,500	B30-R6400
i3300, i5300, BBP33	Fig. 2e	B33-179-494-RD	Red	1.000 (25.4)	1.000 (25.4)	-	0.875 (22.2)	1	1,500	B30-R6400
i3300, i5300, BBP33	Fig. 2e	B33-179-494-YL	Yellow	1.000 (25.4)	1.000 (25.4)	-	0.875 (22.2)	1	1,500	B30-R6400

Dissolvable Paper Labels

(B-403)

- Designed for temporary applications where easy removal, re-identification or waste reduction are valued
- Ideal for labeling vials, tubes or general glassware, temporary asset tracking, animal housing identification, and general use
- Completely dissolves in warm water within 30 seconds, leaving no adhesive residue

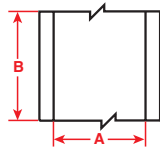

Figure 3



For Use with Printers:	Diagram	Catalog #	B#	Color	Label Width A Inch (mm)	Roll Length B Inch (mm)	Labels Per Roll	Rec. Ribbon
i3300, i5300, BBP33	Fig. 3	B30C-1125-403-WT	B-403	White	1.125 (28.575)	100 (30.5)	1 (cont.)	B30-R4300
i3300, i5300, BBP33	Fig. 3	B30C-2250-403-WT	B-403	White	2.250 (57.15)	100 (30.5)	1 (cont.)	B30-R4300
i3300, i5300, BBP33	Fig. 3	B30C-3000-403-WT	B-403	White	3.000 (76.2)	100 (30.5)	1 (cont.)	B30-R4300
i3300, i5300, BBP33	Fig. 3	B30C-4000-403-WT	B-403	White	4.000 (101.6)	100 (30.5)	1 (cont.)	B30-R4300

Sterilization Indicating Labels

(B-7425-AC)

- Specially designed with a pre-printed “sterilized” header that indicates steam sterilization with a color-changing pre-printed header when autoclaved at 250.7° F (121.5° C) for 10 minutes
- Withstands temperature ranges from -320° to 248° F (-196° to 121° C)
- For use in LN2, freezers, autoclave and hot water baths
- Chemical resistance to ethanol, DMSO, IPS, short-term xylene, 10% formalin, 50% acetic acid and toluene

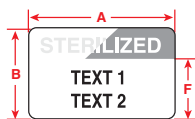

Figure 29a



For Use with Printers:	Diagram	Catalog #	B#	Color	Label Width A Inch (mm)	Label Height B Inch (mm)	Print Area Height F Inch (mm)	Labels Per Row	Labels Per Roll	Rec. Ribbon
i3300, i5300, BBP33	Fig. 29a	B33-235-7425-AC	B-7425-AC	White	1.500 (38.1)	1.000 (25.4) *	0.750 (19.1)	1	1250	B30-R4300
i3300, i5300, BBP33	Fig. 29a	B33-137-7425-AC	B-7425-AC	White	2.000 (50.8)	1.000 (25.4) *	0.750 (19.1)	1	1500	B30-R4300

Tissue Cassette Labels

(B-481)

- White polyester label with superior resistance to tissue processing chemicals and embedding procedures. Use with the BSP™31 Label Attachment system for pre-process tissue cassette identification

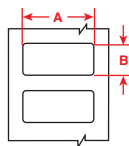

Figure 2



For Use with Printers:	Diagram	Catalog #	B#	Color	Label Width A Inch (mm)	Label Height B Inch (mm)	Labels Per Row	Labels Per Roll	Rec. Ribbon
i3300, i5300, BBP33	Fig. 2	B33-199-481	B-481	White	1.050 (26.7)	0.250 (6.4)	1	3000	B30-R6400
i3300, i5300, BBP33	Fig. 2	B33-213-481	B-481	White	1.050 (26.7)	0.313 (8)	1	3000	B30-R6400

General Identification for Laboratory Storage, Equipment and Safety Labels

(B-499, B-595, B-7569)

- Super strong adhesives and colors ideal for marking laboratory equipment, containers, hoses and lab storage cabinets, shelves and drawers
- GHS labels available for marking chemicals in the lab and shipment boxes when collaborating with other labs
- Pre-printed sign header labels make your safety and housekeeping reminders stand out and stay put!

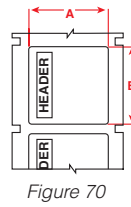
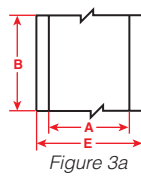
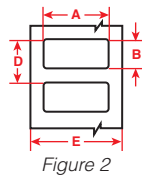
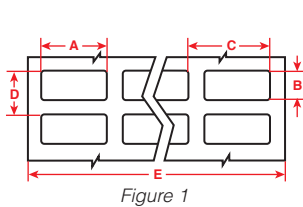

Diagram	Catalog #	Color / Legend	Label Width A Inch (mm)	Label Height B Inch (mm)	Horiz. Repeat C Inch (mm)	Vert. Repeat D Inch (mm)	Web Width E Inch (mm)	Roll Length B Feet (m)	Labels Per Row	Labels Per Roll	Rec. Ribbon
Nylon Cloth - Permanent Adhesive (B-499):											
Fig. 1	B33-68-499	White	0.500 (12.7)	0.750 (19.1)	0.600 (15.2)	0.875 (22.2)	2.500 (63.5)	–	4	1500	B30-R6000
Fig. 1	B33-165-499	White	0.800 (20.3)	1.437 (36.5)	0.900 (22.9)	1.562 (39.7)	3.700 (94.0)	–	4	2500	B30-R6000
Fig. 2	B33-125-499	White	0.900 (22.9)	0.500 (12.7)	–	–	–	–	1	1500	B30-R6000
Fig. 1	B33-126-499	White	0.900 (22.9)	0.500 (12.7)	–	–	–	–	2	1500	B30-R6000
Fig. 2	B33-163-499	White	1.000 (25.4)	0.375 (9.5)	–	–	–	–	1	1500	B30-R6000
Fig. 1	B33-152-499	White	1.000 (25.4)	0.375 (9.5)	–	–	–	–	2	1500	B30-R6000
Fig. 2	B33-136-499	White	1.500 (38.1)	0.750 (19.1)	–	0.875 (22.2)	1.770 (45.0)	–	1	1500	B30-R6000
Fig. 2	B33-137-499	White	2.000 (50.8)	1.000 (25.4)	–	1.125 (28.6)	2.200 (55.9)	–	1	1100	B30-R6000
Fig. 2	B33-125-499	White	2.000 (50.8)	0.250 (6.4)	–	–	–	–	1	1500	B30-R6000
Indoor/Outdoor Vinyl (B-595):											
Fig. 3a	B30C-500-595-WT	White	0.500 (12.7)	–	–	–	–	100 (30.5)	–	1 roll (cont.)	B30-R10000
Fig. 3a	B30C-1125-595-WT	White	1.125 (28.6)	–	–	–	–	100 (30.5)	–	1 roll (cont.)	B30-R10000
Fig. 3a	B30C-500-595-YL	Yellow	0.500 (12.7)	–	–	–	–	100 (30.5)	–	1 roll (cont.)	B30-R10000
Fig. 3a	B30C-1125-595-YL	Yellow	1.125 (28.6)	–	–	–	–	100 (30.5)	–	1 roll (cont.)	B30-R10000
Fig. 3a	B30C-500-595-RD	Red	0.500 (12.7)	–	–	–	–	100 (30.5)	–	1 roll (cont.)	B30-R10000-WT
Fig. 3a	B30C-1125-595-RD	Red	1.125 (28.6)	–	–	–	–	100 (30.5)	–	1 roll (cont.)	B30-R10000-WT
Fig. 3a	B30C-500-595-BL	Blue	0.500 (12.7)	–	–	–	–	100 (30.5)	–	1 roll (cont.)	B30-R10000-WT
Fig. 3a	B30C-1125-595-BL	Blue	1.125 (28.6)	–	–	–	–	100 (30.5)	–	1 roll (cont.)	B30-R10000-WT
Fig. 3a	B30C-500-595-GN	Green	0.500 (12.7)	–	–	–	–	100 (30.5)	–	1 roll (cont.)	B30-R10000-WT
Fig. 3a	B30C-1125-595-GN	Green	1.125 (28.6)	–	–	–	–	100 (30.5)	–	1 roll (cont.)	B30-R10000-WT
Pre-Printed Pre-Cut Blank Sign Headers (B-595):											
Fig. 70	B30-241-595-ANSIDA		2.250 (57.5)	3.000 (76.2)	–	–	–	–	1	300	B30-R10000
Fig. 70	B30-25-595-ANSIDA		4.000 (101.6)	6.000 (152.4)	–	–	–	–	1	175	B30-R10000
Fig. 70	B30-241-595-ANSINO		2.250 (57.5)	3.000 (76.2)	–	–	–	–	1	300	B30-R10000
Fig. 70	B30-25-595-ANSINO		4.000 (101.6)	6.000 (152.4)	–	–	–	–	1	175	B30-R10000
Pre-Printed GHS/CLP Chemical (B-7569):											
L4B Diamond + Text	B30-260-7569-CLP4B		2.170 (55.0)	3.350 (85.1)	–	–	–	–	1	340	B30-R10000
L4B Diamond + Text	B30-261-7569-CLP4B		2.950 (75.0)	4.330 (110.0)	–	–	–	–	1	270	B30-R10000
L4C Diamond + Text	B30-18-7569-CLP4C		1.000 (25.4)	3.000 (76.2)	–	–	–	–	1	1000	B30-R10000

(B-595) U.S. Patent Nos. 5,823,689; 6,570,602. Additional Patents Pending.

All part numbers above are compatible with BradyPrinter i3300, i5300, and BBP®33. Parts may also be compatible with BradyPrinter S3000, BradyPrinter S3100, BBP®30, BBP®31, BBP®35 and BBP®37 printers. Visit BradyID.com to confirm compatibility.

Print Ribbons

Drop and Click print ribbons for 5-second ribbon supply changes

- Tough, smear-proof ribbons that produce long-lasting printed text and can withstand years in industrial areas and outdoor conditions
- Self-contained cartridges drop straight into printer with a “click”
- No calibrating, no threading, no wasted feeding, no hassles and the ink will always be facing the right direction!
- Printer notifies user if installed ribbon is not recommended for installed labels



Installs in 5 seconds...just snap into place!

Single-Color Print Ribbons

Catalog #	Color	Size Inch (mm)	Length Feet (m)
B30-R10000	Black	4.330 (109.9)	200 ft. (60.9 m)
B30-R4300	Black	4.330 (109.9)	200 ft. (60.9 m)
B30-R4900	Black	4.330 (109.9)	200 ft. (60.9 m)
B30-R6000	Black	4.330 (109.9)	200 ft. (60.9 m)
B30-R6200	Black	4.330 (109.9)	200 ft. (60.9 m)
B30-R6300	Black	4.330 (109.9)	200 ft. (60.9 m)
B30-R6400	Black	4.330 (109.9)	200 ft. (60.9 m)
B30-R6600	Black	4.330 (109.9)	200 ft. (60.9 m)
B30-R10000-WT	White	4.330 (109.9)	200 ft. (60.9 m)
B30-R4400-WT	White	4.330 (109.9)	200 ft. (60.9 m)
B30-R6700-WT	White*	4.330 (109.9)	200 ft. (60.9 m)
B30-R6800-WT	White***	4.330 (109.9)	200 ft. (60.9 m)
B30-R4500-SV	Silver*	4.330 (109.9)	200 ft. (60.9 m)
B30-R10000-RD	Red****	4.330 (109.9)	200 ft. (60.9 m)
B30-R10000-GN	Green****	4.330 (109.9)	200 ft. (60.9 m)
B30-R10000-BL	Blue****	4.330 (109.9)	200 ft. (60.9 m)
B30-R10000-YL	Yellow** / ****	4.330 (109.9)	200 ft. (60.9 m)
B30-R10000-YL2	Yellow** / ****	4.330 (109.9)	200 ft. (60.9 m)
B30-R10000-OR	Orange****	4.330 (109.9)	200 ft. (60.9 m)
B30-R10000-MA	Magenta****	4.330 (109.9)	200 ft. (60.9 m)

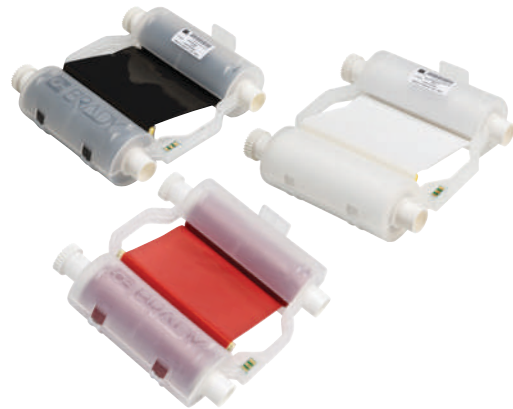

* B30-R4500-SV ribbon for use with B-342 black and B-345 black sleeves only; B30-R6700-WT ribbon for use with B-345 black sleeves only.

** B30-R10000-YL for printing yellow onto white. B30-R10000-YL2 for printing yellow onto other colors of B-595.

*** B30-R6800-WT for use with B-8117 black labels only.

**** Colored ribbons optimized for use on white material. Test use on other material colors for suitability to your application.

Print Ribbon / Label Material Compatibility

To ensure the best legend permanence, all ribbons have been developed to meet the requirements of the materials to be printed on. Use the guide below to determine which ribbon series is recommended with your print materials.



●	Recommended ribbon for use with respective material.
▲	Acceptable ribbon for use with respective material.
UL	Materials are UL recognized with its respective ribbon.
CSA	Materials are CSA approved with its respective ribbon.

B-# material		B30-R4300	B30-R4900	B30-R6000	B30-R6200	B30-R6300	B30-R6400	B30-R6600	B30-R10000	B30-R4500-SV*	B30-R4400-WT	B30-R6700-WT*	B30-R6800-WT***	B30-R10000-WT	B30-R10000-YL**	B30-R10000-YL2**	B30-R10000****	
B-342	Polyolefin	●	-	-	-	-	-	●	-	-	-	-	-	-	-	-	-	-
B-342 BLK	Polyolefin	-	-	-	-	-	-	-	-	●	-	-	-	-	-	-	-	-
B-344	Polyolefin	-	-	-	-	-	-	●	-	-	-	-	-	-	-	-	-	-
B-344 YEL	Polyolefin	●	-	-	-	-	-	●	-	-	-	-	-	-	-	-	-	-
B-344 BLK	Polyolefin	-	-	-	-	-	-	-	-	-	●	-	-	-	-	-	-	-
B-345	Polyolefin	-	-	▲	-	-	-	●	-	-	-	-	-	-	-	-	-	-
B-345 BLK	Polyolefin	-	-	-	-	-	-	-	-	●	●	-	-	-	-	-	-	-
B-403	Paper	●	-	-	-	-	-	-	-	-	-	-	-	-	-	-	-	-
B-413	Polyester	-	-	● UL	-	-	-	-	-	-	-	-	-	-	-	-	-	-
B-414	Printable VELCRO® Hook	-	-	●	●	-	-	-	-	-	-	-	-	-	-	-	-	-
B-417	Vinyl	● UL	-	-	-	-	-	-	-	-	-	-	-	-	-	-	-	-
B-422	Polyester	-	-	● UL / CSA	●	-	-	-	-	-	-	-	-	-	-	-	-	-
B-423	Polyester	-	-	● UL / CSA	▲	-	-	-	-	-	-	-	-	-	-	-	-	-
B-424	Paper	●	-	-	-	-	-	-	-	-	-	-	-	-	-	-	-	-
B-425	Polypropylene	● UL / CSA	-	-	-	-	● UL / CSA	-	-	-	-	-	-	-	-	-	-	-
B-427	Vinyl	● UL	-	-	-	-	-	-	-	-	-	-	-	-	-	-	-	-
B-428	Metallized Polyester	● UL / CSA	-	-	-	-	-	-	-	-	-	-	-	-	-	-	-	-
B-430	Polyester	-	-	● UL / CSA	-	-	-	-	-	-	-	-	-	-	-	-	-	-
B-432	Clear Polyester	-	▲ UL	● UL / CSA	-	-	-	-	-	-	-	-	-	-	-	-	-	-
B-434A	Metallized Polyester	-	-	● UL / CSA	-	-	-	-	-	-	-	-	-	-	-	-	-	-
B-435	Metallized Polyester	-	-	● UL / CSA	-	-	-	-	-	-	-	-	-	-	-	-	-	-
B-437	Polyvinylfluoride	●	-	-	-	-	-	-	-	-	-	-	-	-	-	-	-	-
B-437 YEL	Polyvinylfluoride	●	-	-	●	-	-	-	-	-	-	-	-	-	-	-	-	-
B-438	Metallized Polyester	● UL / CSA	-	-	-	-	-	-	-	-	-	-	-	-	-	-	-	-
B-439	Vinyl	-	-	●	-	-	-	-	-	-	-	-	-	-	-	-	-	-
B-443	Polyester	-	-	-	-	-	● UL / CSA	-	-	-	-	-	-	-	-	-	-	-
B-461	Polyester	●	-	-	▲	-	-	-	-	-	-	-	-	-	-	-	-	-
B-472	Polyimide	●	-	-	●	-	-	-	-	-	-	-	-	-	-	-	-	-
B-473	Polyester	-	-	● UL / CSA	-	-	-	-	-	-	-	-	-	-	-	-	-	-
B-481	Polyester	-	-	-	-	-	●	-	-	-	-	-	-	-	-	-	-	-
B-483	Polyester	-	-	● UL / CSA	-	-	-	-	-	-	-	-	-	-	-	-	-	-
B-483A	ToughStripe® Polyester	-	-	●	-	-	-	-	-	-	●	-	-	-	-	-	-	-
B-484A	Polyester	-	-	● UL	-	-	-	-	-	-	-	-	-	-	-	-	-	-
B-486B	Metallized Polyester	● UL / CSA	-	-	-	-	-	-	-	-	-	-	-	-	-	-	-	-

For further material compatibility related to UL/CSA, see pages 18-22 or refer to Brady Tech Data Sheet for complete material performance specifications

Print Ribbon / Label Material Compatibility

●	Recommended ribbon for use with respective material.
▲	Acceptable ribbon for use with respective material.
UL	Materials are UL recognized with its respective ribbon.
CSA	Materials are CSA approved with its respective ribbon.

B-# material		B30-R4300	B30-R4900	B30-R6000	B30-R6200	B30-R6300	B30-R6400	B30-R6600	B30-R10000	B30-R4500-SV*	B30-R4400-WT	B30-R6700-WT*	B30-R6800-WT***	B30-R10000-WT	B30-R10000-YL***	B30-R10000-YL2***	B30-R10000-****
B-489A	Polyester	● UL / CSA	-	-	-	-	-	-	-	-	-	-	-	-	-	-	-
B-490	Polyester	●	-	-	-	-	-	-	-	-	-	-	-	-	-	-	-
B-492	Polyester	-	-	-	-	-	●	-	-	-	-	-	-	-	-	-	-
B-494	Polyester	-	-	-	-	-	●	-	-	-	-	-	-	-	-	-	-
B-498	Repos Cloth	▲ UL	-	-	● UL	-	-	-	-	-	-	-	-	-	-	-	-
B-499	Nylon Cloth	▲ UL / CSA	-	● UL	-	-	-	-	-	-	-	-	-	-	-	-	-
B-509	Printable Magnetic	-	-	●	-	-	-	-	●	-	-	-	-	-	-	-	●
B-526	Photoluminescent Polyester	-	-	●	-	-	-	-	●	-	-	-	-	-	-	-	●
B-549	Polyester	-	-	●	-	-	-	-	●	-	-	-	-	-	-	-	●
B-551	Non-Adhesive Tag	-	-	●	-	-	-	-	●	-	-	-	-	-	-	-	●
B-569	Polyester	-	-	●	-	-	-	-	●	-	-	-	-	●	-	-	●
B-581	Repos Vinyl	-	-	●	-	-	-	-	●	-	-	-	-	-	-	-	●
B-584	Reflective	-	-	●	-	-	-	-	●	-	-	-	-	-	-	-	●
B-593	Polyester	-	-	●	-	-	-	-	-	-	●	-	-	-	-	-	-
B-595	Outdoor Vinyl	-	-	●	-	-	-	-	●	-	-	-	-	●	-	●	●
B-618	Polyester	-	● UL	● UL	-	-	-	-	-	-	-	-	-	-	-	-	-
B-717	Polyimide	-	-	● UL	-	-	-	-	-	-	-	-	-	-	-	-	-
B-718	Polyimide	-	-	● UL	-	-	-	-	-	-	-	-	-	-	-	-	-
B-719	Polyimide	-	-	● UL	-	-	-	-	-	-	-	-	-	-	-	-	-
B-724	Polyimide	●	-	-	-	-	-	-	-	-	-	-	-	-	-	-	-
B-727	Polyimide	-	-	● UL	-	-	-	-	-	-	-	-	-	-	-	-	-
B-728	Polyimide	-	-	● UL	-	-	-	-	-	-	-	-	-	-	-	-	-
B-729	Polyimide	-	-	● UL	-	-	-	-	-	-	-	-	-	-	-	-	-
B-777	Polyimide	-	-	●	-	● UL / CSA	-	-	-	-	-	-	-	-	-	-	-
B-854	ToughWash® Metal Detectable	-	-	●	-	-	-	-	-	-	-	-	-	-	-	-	-
B-855	ToughWash	-	-	●	-	-	-	-	-	-	-	-	-	-	-	-	-
B-7425	Polypropylene	▲	-	-	-	-	●	-	-	-	-	-	-	-	-	-	-
B-7425-AC	Polypropylene	▲	-	-	-	-	●	-	-	-	-	-	-	-	-	-	-
B-7569	Vinyl Film	-	-	●	-	-	-	-	●	-	-	-	-	-	-	-	-
B-7641	Polyolefin	-	-	●	-	-	-	●	-	-	-	-	-	-	-	-	-
B-7642	Polyolefin	●	-	-	-	-	●	-	-	-	-	-	-	-	-	-	-
B-7643	Polyurethane	-	-	●	-	-	-	-	-	-	-	-	-	-	-	-	-
B-8117	Black Polyester	-	-	-	-	-	-	-	-	-	▲ UL	-	● UL	-	-	-	-
B-8591	Outdoor Polyester	-	-	● UL	-	-	-	● UL	-	-	-	-	-	-	-	-	-
B-8591 SLV	Outdoor Polyester	-	-	-	-	-	-	● UL	-	-	●	-	-	-	-	-	-
B-8591 BLK	Outdoor Polyester	-	-	-	-	-	-	-	-	-	● UL	-	-	-	-	-	-

For further material compatibility related to UL/CSA, see pages 18-22 or refer to Brady Tech Data Sheet for complete material performance specifications

Printer Specifications

Model(s):	
Model name	BradyPrinter i5300 Industrial Label Printer
Media alignment	Center justified
Volume guidelines*	5,000+ labels per day. 5 days per week
Printhead / Printing Characteristics:	
Print resolution	300 dpi model 600 dpi model
Print method	Thermal transfer, direct transfer
Cutter type / Auto cutter	Auto cutter built-in (all models)
Print color capability	Single color
Print speed	up to 7 in. / sec – die cuts (300 dpi) up to 10 in. / sec – continuous (300 dpi) up to 3 in. / sec – die cuts (600 dpi) up to 5 in. / sec – continuous (600 dpi)
Print width (max, cross-web)	4.015 in.
Print length (max, down-web)	5.0 ft.
Print job interrupt options	Resume print job where pause or interruption occurs, or select specific label in job
Printhead replacement	Field replaceable (with same dpi only)
Print roller replacement	Field replaceable (T10 wrench required)
Print on demand	Yes
Print pause	Yes
Print job list on stand-alone printer	Yes - BradyWorkstation print jobs can be saved to printer for later on-printer selection and placement into a print queue. This function also write-protects the print jobs from unwanted editing.
Interface:	
Display type	Color LCD touchscreen
Display size (diagonal)	7.0 in.
Display resolution (H x W)	600 x 1024 pixels
Display languages	Bahasa Indonesia, Bahasa Melayu, Bulgarian, Chinese (simplified), Chinese (traditional), Croatian, Czech, Danish, Dutch, Estonian, Finnish, French, German, Hungarian, Italian, Japanese, Korean, Norwegian, Polish, Portuguese, Romanian, Russian, Slovakian, Slovenian, Spanish, Swedish, Turkish, Thai, Vietnamese
Display status bar	Installed ribbon and label part numbers, amount of supplies remaining, Wi-Fi connection, Bluetooth connection, receiving data icon, ready state / error state
Media Characteristics:	
Label width (cross-web)	0.25 in. to 4.25 in. (continuous linerless media) 0.25 in. to 4.015 in. (other media)
Label length (down-web)**	0.20 in. minimum (die-cut media) 0.50 in. minimum (continuous media)
Media roll o.d. (max)	4.30 in.
Media roll core i.d.	n/a (media roll integrated into drop-in cartridge)
Media width (cross-web, including liner)	0.71 in. to 4.25 in.
Media thickness	0.0024 in. to 0.031 in. max (label media) 0.070 in. max (B-593 push-button media) 0.043 in. max (heat-shrink sleeves)
Media roll winding	n/a
PrintSmart technology	Yes - Reads datachip on supplies for no-waste printing, requires no calibration, has pre-optimized energy and speed settings and features auto label setup in Brady software
Sensor and energy setting adjustments	No calibration required, no wasted labels, sensor; speed and heat settings are auto-set
Media loading / handling	Labels: In cartridge, drops into place, 15-second changeover Ribbon: In cartridge, snaps into place, 5-second changeover
Media parts offering	1,300+ stock parts and custom (made-to-request) parts. All B30- and B33- series parts are compatible in the BradyPrinter i5300
Media styles	All media is on an integrated cartridge roll with part data on the smart cell. Die-cut media, continuous media, tagstock liner-mounted, tagstock linerless, perforated materials, adhesive labels, heat-shrink sleeves size 0.940 in. and larger (single- and double-sided with 2-pass print), self-laminating cable labels, cable ties and tags, raised panel push-button labels, rapido-style cable tags, PermaShield-style labels, pre-printed GHS labels, SFID outdoor-grade labels, direct thermal labels
Media material types	PE (polyethylene), PET (polyester), PET (metallized), PU (polyurethane), PVC (vinyl), PVF (polyvinyl fluoride), PVDF (polyvinylidene fluoride), PP (polypropylene), PI (polyimide), polyamide, polyether polyurethane (Heatex™), raised panel push-button material, paper, tamper-evident and tamper-resistant materials, 8-10 year outdoor vinyl, 10-hour glow-in-the-dark material, retroreflective labels, printable floor marking tape, nylon and vinyl cloth, wash-down materials, extreme temperature laboratory materials, slides / lab-staining materials, other materials not listed

Ribbon Characteristics:	
Ribbon length (max)	200 ft.
Ribbon roll o.d. (max)	n/a (ribbon roll integrated into drop-in cartridge)
Ribbon roll core i.d.	n/a (ribbon roll integrated into drop-in cartridge)
Ribbon width (cross-web)	4.33 in.
Ink side	n/a (ribbon integrated in cartridge — guaranteed correct orientation to printhead)
Software and Firmware:	
Label Creation Software	Brady Workstation (v4.12 or newer) and Brady Workstation apps (latest updates)
WHQL certified Windows® drivers	Windows 7, 8, 8.1, 10, server 2008, 2008 R2, 2012, 2012 R2, 2017
Printer command language	BPL – scripting commands for sending scripts to the printer
Connectivity:	
PC connection port	1 x USB 2.0 hi-speed device port
Serial port	No
Ethernet	1 x Ethernet 100 BASE-T
USB host ports	3 x USB 2.0 type A host port (1 front, 2 back)
SD card slot	No
Wireless	Wi-Fi 802.11b/g/n (wireless model only)
Bluetooth	Internal Bluetooth module (future functionality)
Electronics:	
Processor	32-bit 800 MHz clock rate
Memory (RAM)	512 MB
Data storage (IFFS)	195 MB
Internal battery	For internal date and time (RTC)
Data storage when power Off	Yes
Physical / Operational Characteristics:	
Dimensions (closed) (HxWxD)	11.0 in. x 11.2 in. x 15.8 in.
Weight (empty)	31 lbs
Power supply	101-240 VAC, 50/60 Hz, 3.5A
Power consumption	20W standby / 80W operating / 200W max
Operating environment	50 - 104°F / 10 - 85% RH non condensing
Storage environment	-4 - 122°F / 15 - 90% RH non condensing
Transport environment	-4 - 122°F / 15 - 90% RH non condensing
Agency approvals	CE, FCC class A, cUL. Contact Brady for up-to-date list of environmental compliance information and agency approvals and / or marks covering over 75 countries (awarded or applied for)
Fonts and Graphics:	
Character sets	ASCII character set
Font types (resident)	Arial, Courier New, MS Gothic, Malgun Gothic, MingLiU, SimSun, Tahoma, Times New Roman, Trebuchet MS, Verdana
Font types (storable to printer)	TrueType fonts storable to printer via jump drive
Font attributes	Bold, italic, underlined
Graphic elements	Arrow, line, rectangle, square, circle, ellipse, diamond, dot, star, triangle, seal, cross
Graphic formats	BMP, GIF, JPEG, PNG
Barcodes:	
Barcode symbologies — 2D	Aztec, DataMatrix, QR Code, PDF-417
Barcode attributes	Sizing: variable in height and ratio Rotation: 0°, 90°, 180°, 270° human-readable and human-readable location density
Barcode symbologies — linear	Code 39, Code 93, Code 128 A, B, C, Codabar, EAN-8, EAN-13, JAN-8, JAN-13, HIBC, Interleaved 2 of 5, Interleaved 2 of 5 with check digit, MSI Plessey, UPC-A
Options / Accessories:	
Replacement printheads	User replaceable (to same dpi)
Replacement print rollers	115 mm width, user replaceable (T10 wrench required)
Auto cutter	Built-in

* General volume levels for directional model comparison purposes only. Assumes basic text on 1-in. x 2-in. polyester labels. Actual results vary depending on combination of material, burn and speed settings, label content, ambient temperature and length of print run.

**User should test to the application. Print performance on small parts or parts smaller than a printer's minimum label dimension spec is dependent on multiple factors including print speed, quantity in print run, heat setting, and the size / layout of the printed elements. Windows® is a registered trademark of Microsoft Corporation.

We identify and protect premises, products and people.

For more information or to learn more about our innovative products, visit BradyID.com or call 1-888-272-3946.



Y5079978 MS5079978

USA
Customer Service: 1-888-272-3946
BradyID.com

Canada
Customer Service: 1-800-263-6179
BradyCanada.ca

Mexico
Customer Service: 1-800-262-7777
Inside Sales: 1-800-262-7777 ext 177
BradyID.com.mx

