



BP-PR PLUS & BBP72 Series

Auto Cutter Operator's Manual

Edition 04/10
Y1147483

Information on the scope of delivery, appearance, performance, dimensions and weight reflect our knowledge at the time of printing. We reserve the right to make modifications.

All rights, including those regarding the translation, are reserved. The replication, conversion, duplication or divulgement of the whole manual or parts of it for other intentions than its original intended purpose demand the previous written authorization by **Brady Corporation**.

Edition 04/10



Brady Worldwide
6555 W. Good Hope Road
PO Box 2131
Milwaukee, WI 53201 U.S.A.
Phone: 1-800-537-8791 Fax: 1-800-292-2289



WH Brady
Lindestraat 21
Industriepark C3
9240 Zele Belgium
Tel.: +32 52 457 811
e-mail: support@brady.be

Approval

The transfer printers comply with the following safety guidelines:

- CE** EC Low-Voltage Directive (73/23/EEC) EC Machine Directive (98/37/EC) EC Electromagnetic Compatibility Directive (89/336/EEC)
- FCC** Conditions from Part 15 of the FCC Regulations for Class A computing devices. Operation of these devices may cause radio or television interference under unfavorable conditions, which would need to be remedied by the operator using countermeasures.

Batteries Directive 2006/66/EC



This product contains a lithium battery. The crossed-out wheeled bin is used to indicate 'separate collection' for all batteries and accumulators in accordance with European Directive 2006/66/EC. Users of batteries must not dispose of batteries as unsorted municipal waste. This Directive determines the framework for the return and recycling of used batteries and accumulators that are to be collected separately and recycled at end of life. Please dispose of the battery according to your local regulations.

Notice to Recyclers

To remove the lithium battery:

1. Disassemble printer and locate the lithium cell battery located on the main circuit board.
2. To remove, slide the battery from the coin cell retainer, remove the battery from the board, and dispose of properly.

Contents

Introduction

1-1-Intended Use	1
1-2-Safety Instructions	2
1-3-Environment	3
1-4-Technical Data	3

Mounting

2-1-Mounting the Cutter Tray	4
2-2-Mounting the Cutter	4

Printer Configuration

Loading Material

Operation

5-1-Standard Operation	9
5-2-Operation with External Control	10

Maintenance

6-1-Cleaning	11
6-2-Changing the Blades	13
6-3-Setting Initial State of the Cutter	15

Peripheral Interface

7-1-Pin Assignment	17
7-2-Explanation of Signals	18
7-3-Circuit Diagram of Inputs	20
7-4-Circuit Diagram of Outputs	21

Compliance

8-1-UNITED STATES & CANADA	22
8-2-EU Conformity Declaration	23

1 Introduction

1-1 Intended Use

The device is intended exclusively as an option for the printers of the PR PLUS printer series (serial number 83761+) and BBP72 printer for cutting suitable materials that have been approved by the manufacturer. Any other use or use going beyond this shall be regarded as improper use. The manufacturer/supplier shall not be liable for damage resulting from unauthorized use; the user shall bear the risk alone.

Usage for the intended purpose also includes complying with the operating manual, including the manufacturer's maintenance recommendations and specifications.

The device is manufactured in accordance with the current technological status and the recognized safety rules. However, danger to the life and limb of the user or third parties and/or damage to the device and other tangible assets can arise during use.

The device may only be used for its intended purpose and if it is in perfect working order, and it must be used with regard to safety and dangers as stated in the operating manual.

1-2 Safety Instructions

- Disconnect the printer from the electrical outlet before mounting or removing the cutter.
- The cutter may only be operated when it is mounted on the printer.
- Risk of injury, particularly during maintenance, the cutter blades are sharp.

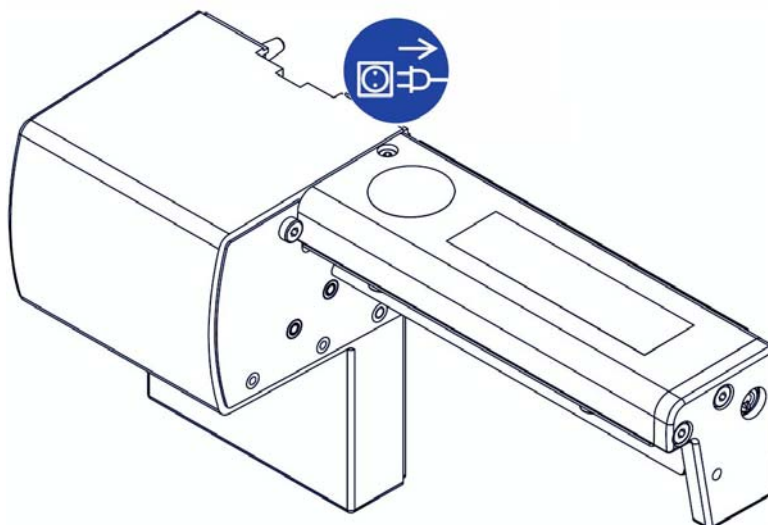

CAUTION!

Rotating knife. Do not touch or put fingers near knife.

- Only trained personnel or service technicians should perform maintenance.
- Unauthorized interference with electronic modules or their software can cause malfunctions. Other unauthorized work or modifications to the device can also endanger operational safety.
- Always have service work done in a qualified workshop, where the personnel have the technical knowledge and tools required to do the necessary work.
- Do not remove warning stickers, as then you and other people cannot be aware of dangers and may be injured.

1-3 Environment



Obsolete devices contain valuable recyclable materials that should be sent for recycling.

- Send to suitable collection points, separately from residual waste.

The modular construction of the printer enables it to be easily disassembled into its component parts.

- Send the parts for recycling.
- Take the electronic circuit boards to public waste disposal centers or to the distributor.

1-4 Technical Data

Standard Cutter	Catalog Number: PR+-AutoCutter-FI
Cutter with peripheral interface *	Catalog Number: PR+-PerfCutter-FI
For printer type	PR-300 PLUS PR-600 PLUS
Material width up to (in/mm)	4.7 / 120
Min. cut length (in/mm)	0.08 / 2
Material thickness (g/m²)	up to 500
Power supply	peripheral connector of the printer
* Interface for trigger switch or external control	

Note: The minimum cut length depends on the media, in particular its adhesive characteristics. Perform preliminary tests. Also test the media, if the media is very hard, very flexible or very thin.

The cutters have a durability of more than 500,000 cuts. Depending on the type of the cut material the blades could wear earlier and have to be replaced. Used blades are not designed regrinding.

An optional Cutter Tray is available:

Cutter Tray 4	Catalog Number: PR+-CutterTray
For printer type	PR 300/600 PLUS, BBP72
Material width (in/mm)	up to 4.7 / 120
Length of the cut pieces (in/mm)	up to 3.9 / 100
Stack height (in/mm)	up to 1.4 / 36

2 Mounting

2-1 Mounting the Cutter Tray

1. Loosen the screws [1].
2. Place the cutter tray [2] on the screws [1] in front of the tear-off plate or the dispense plate and slide it to the left until it stops.
3. Tighten the screws [1].
4. Adjust the length of the cutter tray [2] may by moving the slide [3].

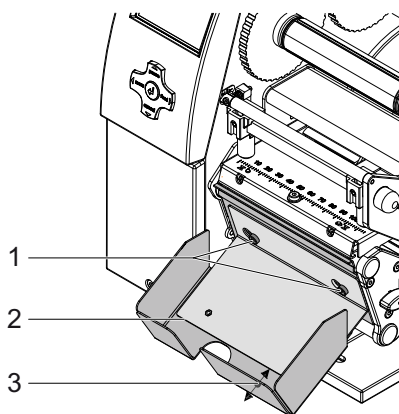

2-2 Mounting the Cutter

Note: Disconnect the printer from the electrical outlet before mounting or removing the cutter.

1. Loosen the screw [2].
2. Remove the front cover [1].

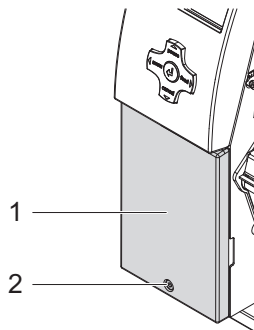

Note: For cutter operation with PR PLUS printer series and BBP72 printer, a tear-off plate or a dispense plate must be mounted on the printer to lead the material through the blades of the cutter.

3. Insert the pins [3] of the cutter [7] into the holes [4] of the printer.
4. Press the cutter against the printer. That way the plug of the cutter will be connected to the peripheral port [5] of the printer.
5. Secure the cutter [7] with the screw [6].

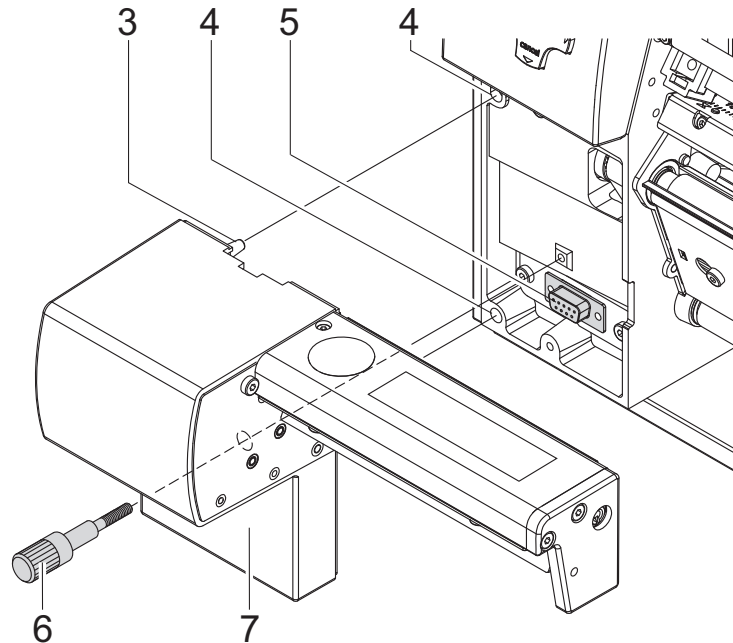

3 Printer Configuration

Once the cutter is connected to the printer, the printer will automatically recognize the cutter when it is turned on.

The printer can be configured to suit the individual requirements of cut mode in the *Setup* menu. When the cutter is installed, the *Cutter* menu will appear.

Note: For detailed configuration instructions see the printer User Manual.

Note: Print driver version v4.6.21 or higher is recommended.

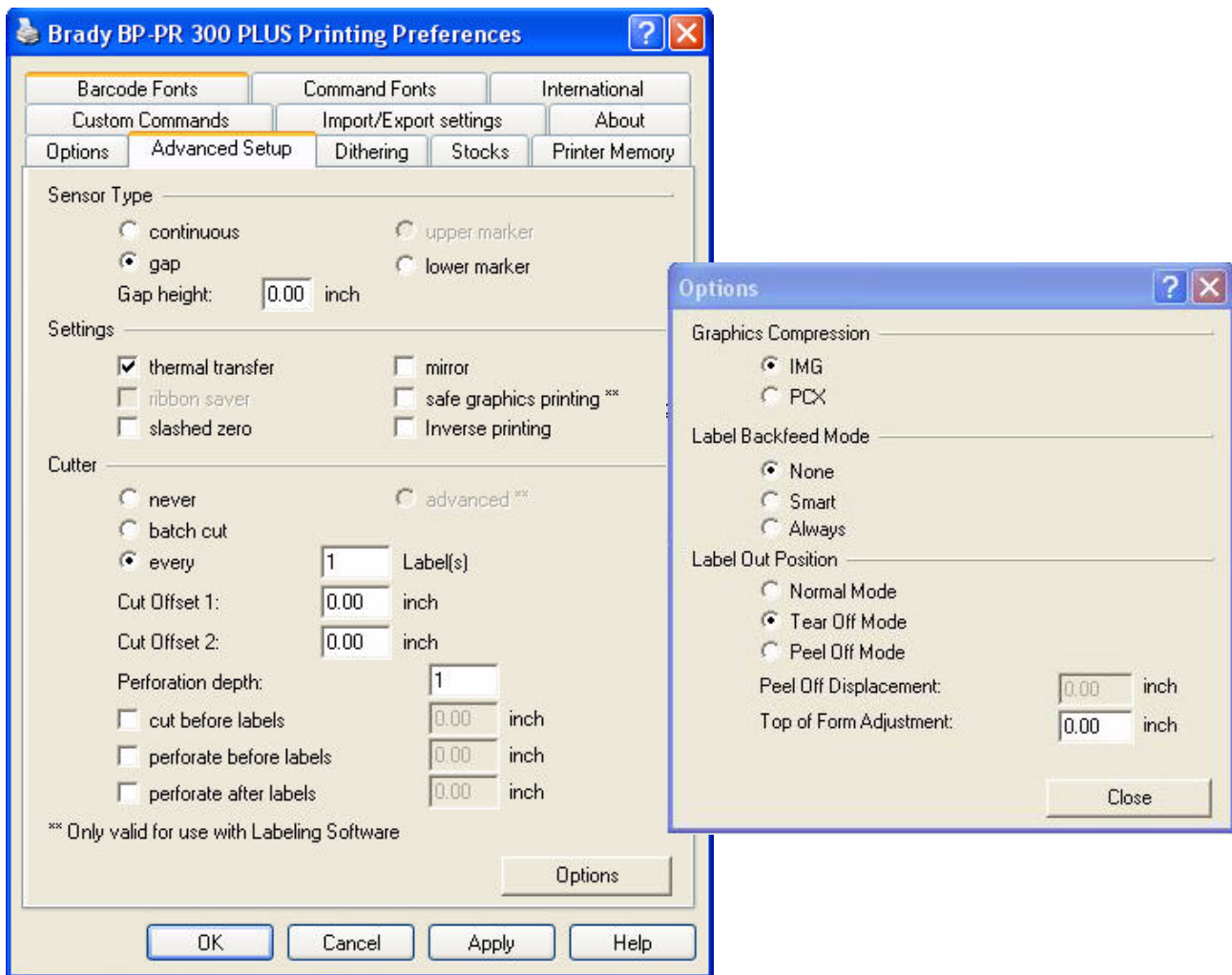

The cutter requires additional setup in the driver:

1. Select **Advanced Setup** tab and set the following options:
 - **Sensor Type:** Set to material used
 - **Cutter:** batch cut or every





1. For setting the cutter parameters select:



Setup  > Machine param.  > Cutter .

Parameter	Meaning	Default
 Cutter	Configuration of the cutter	
 > Cut position	Offset of the cut position relative to the printed image. Cut position with the initial offset value of “0” causes to cut in the middle of the gap between two labels. If the cut position value is positive, the media will be advanced before it is cut, that means the distance between the cut edge and the rear edge of the label increases.	0

Notes:

- The values of the setup are basic settings for the actual combination printer/ cutter. After changing the cutter or printer, a re-adjustment may be necessary.
- Changes required for processing different print jobs should be implemented in additional offsets available in the software.
- The offset values from setup and software are added together for execution.

2. Select the method for recognizing the material and the method of backfeed when using cut mode under **Setup**  -> **Print parameters** .

Parameter	Meaning	Default
 Label sensor	<p>Method for detecting the starting end of the label.</p> <p>Gap Sensor: Detection using changes in the transparency between the label and label gap.</p> <p>Bottom-Reflect: Detection using reflex marks on the bottom of the medium.</p> <p>Continuos media: Synchronization of the paper feed when using endless media in cutting mode.</p> <p>▶ After loading media press the feed key to recognize a short feed and synchronization cut.</p>	Gap sensor
 Backfeed	<p>Method for backfeeding the material.</p> <p>Backfeeding is necessary in the cutting mode since the front edge of a second section already passes the print line when the first label is moved to the cut position.</p> <p>always: Backfeeding occurs independently of print contents.</p> <p>smart: Backfeeding only occurs when the print contents of the next section is not yet fully prepared when cutting the current section. Otherwise, the second section is pushed on and completed after removal of the first section without backfeeding.</p>	smart

4 Loading Material

- Load transfer ribbon and endless material as described in the printer's Operator's Manual.
Use the tear-off mode information for loading endless material for cut mode.
- Place the media strip between the printhead and the drive roller, so that the front edge of the strip reaches through the cutter.

Note: To prevent jamming, we recommend that material is loaded so that it exits from the top of the roll.

5 Operation

5-1 Standard Operation

The printer is ready for operation when all connections have been made and all materials are loaded correctly.

Note: To operate the cutter with continuous material in the printer menu, select **Setup > Print parameters>Label sensor** the setting *Endless media*. Otherwise no synchronization cut is performed.

1. Switch on the printer. The cutter performs a cut.
2. Press the feed key. For synchronization the media will be moved forward and cut off.
Printers synchronization is not necessary when the printhead was not opened between print jobs, even if the printer was powered off between print jobs.
3. Activate the cut mode in the software.
For direct programming use the C-command (see the Programming Manual).
4. Send a print job.

All labels in the job will be printed without stopping and be cut as chosen in the software: after each label, after a specific quantity of labels, or at the end of a print job.

5-2 Operation with External Control

The auto cutters with peripheral interface additionally allow the mode “Cut on Demand”.

In this operating mode it is necessary to connect a trigger switch or an external control to the peripheral interface on the cutter.

Note: This operating mode requires that there is a connection between Pin 13 (STA) and Pin 12 (GND) at the peripheral interface (see chapter “Peripheral Interface”).

The printout of one label or a number of labels with the following cut will be executed if:

- a print job is available.
- the previous cut has finished.
- the trigger switch, or the external control sends the START signal.

6 Maintenance

6-1 Cleaning



WARNING

Disconnect the printer from the electrical outlet.



DANGER!

Risk of injury. The cutter blades are sharp.

1. Remove the cutter from the printer.
2. Loosen the screws [2,4] and remove the cover sheets [1,3].
3. Remove dust and paper particles with a soft brush or a vacuum.
4. For cleaning the circular blade it is possible to turn the axle [6] with a screwdriver for slotted head screws (slot width 7 mm). The rotation angle of the circular blade is limited to 120°.

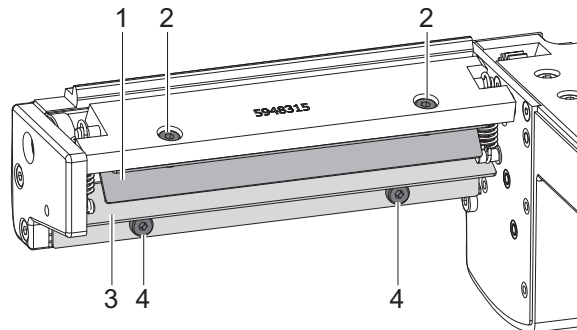

5. If it is necessary to turn the circular blade further, loosen the screw [5] about 5 mm. Now the circular blade can be turned completely.
6. Remove all deposits on cutter blades with isopropyl alcohol and a soft cloth.

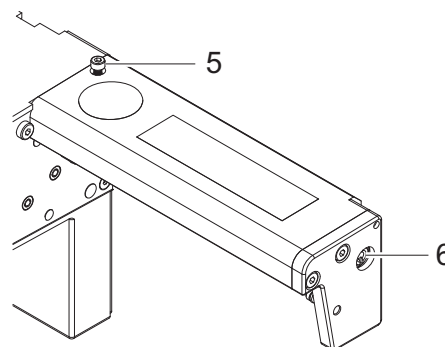

Note: When cutting through the label material instead of the label gap, remains of adhesive may accumulate on the blades. If operating in backfeed mode, such remains of adhesive may be deposited on the drive roller as well. Clean the drive roller (see Printer Operator's Manual) and the cutter blades often.

7. Grease the cylindrical area [7] of the circular blade [8] with an all-around high quality grease. For that hold a greased brush on the cylindrical area and turn the axle [6] with a screwdriver for slotted head screws (slot width 7 mm). During the turning the area is all-around greased.
8. If the screw [5] was loosened during cleaning, adjust the initial state of the cutter (see "6-3: Setting Initial State of the Cutter" on page 14) .
9. Re-mount the cover sheet [1] using the screws M4x6 [2] and cover sheet [3] using the screws M4x10 [4].

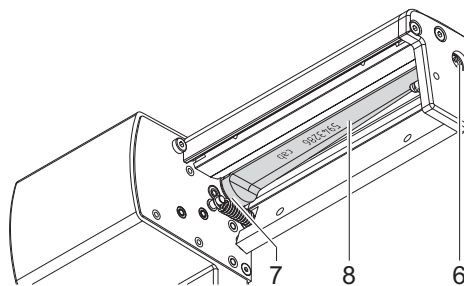

6-2 Changing the Blades



WARNING

Disconnect the printer from the electrical outlet.

1. Remove the cutter from the printer.
2. Remove the cover sheets (see "6-1: Cleaning" on page 10).
3. Turn the axle [3] of the circular blade [2] with a screwdriver for slotted head screws (slot width 7 mm) so that the inscription [1] of the blade points downward. In this position the set screw [4] on the gear wheel can be achieved from the rear of the cutter.
4. Loosen the set screw [4] a few turns.

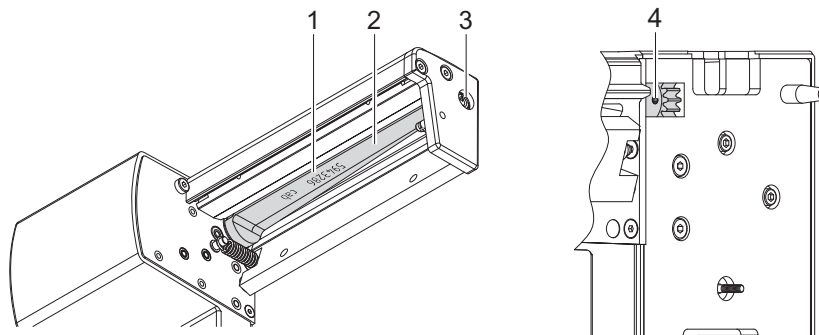

Note: Save the washers (A, B, C) for the circular blade [2] and the lineal blade [12] when dismantling the cutter.



CAUTION!

The springs [6, 15] are tense. Always hold lineal blade [12] in its position tightly and push its axle slightly to the mounting plate [9] of the cutter.

5. Loosen the screws [8] and remove the bearing plate [15]. The spring [13] becomes slack.
6. Remove spring [13] from the lineal blade.
7. Pull the circular blade [2] out of the bearing [5]. The spring [6] at the lineal blade becomes slack.

Note: If the lineal blade should not be changed, skip to step 11.

8. Remove spring [6] and lineal blade [12].
9. Insert the axle of the (new) lineal blade with the washer (B) in the bearing [10] of the mounting plate.
10. Hang in the slack spring [9] to the pins of the mounting plate [9] and the lineal blade [11].

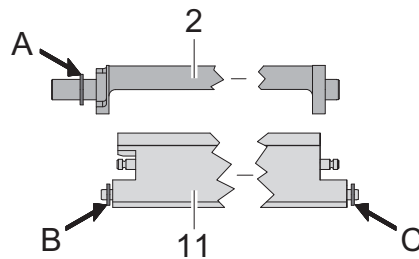
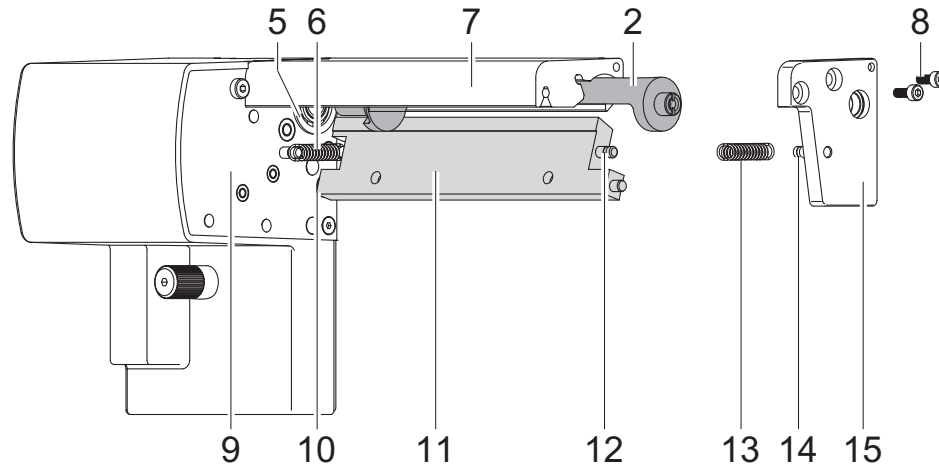

11. Turn the lineal blade [11] backwards. The spring [6] gets tense.
12. Insert the Axle of the (new) circular blade [2] with the washer (A) in the bearing [5] of the mounting plate.
13. Place the washer (C) on the axle of the lineal blade.
14. Hang in the slack spring [13] to the pins [12,14] of the lineal blade and the bearing plate.
15. Push the bearing plate [15] onto the blade axles [2, 11]. The spring [13] gets tense.
16. Append the bearing plate [15] to the profile [7] using the screws [8].
17. Attend on an accurate position of the bearing plate [15] to the profile [7] of the cutter and tighten the screws [8].
18. Tighten the set screw [4] at the gear wheel.
19. Lubricate the circular blade (see "6-1: Cleaning" on page 10) and adjust its initial state (see "6-3: Setting the Initial State of the Cutter" on page 14).
20. Re-mount the cover sheets (see "6-1: Cleaning" on page 10).

6-3 Setting Initial State of the Cutter

To operate the cutter correctly after cleaning or after changing the blades the circular blade [4] and the clock wheel [11] must be adjusted to each other.

1. Unscrew the screws [1], [3] and [6, at the rear].
2. Remove the cover [2].

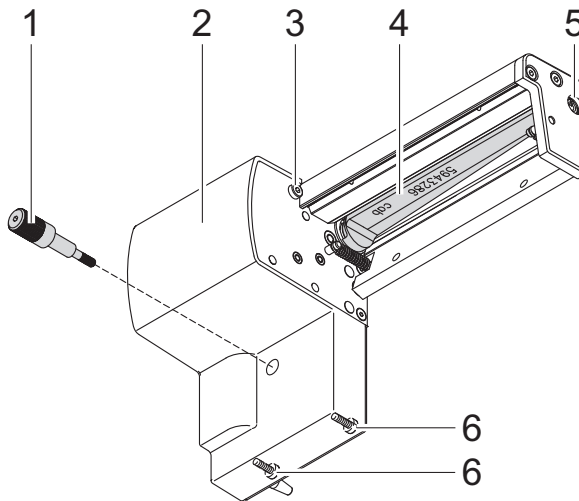

3. Turn the axle [5] of the circular blade with a screwdriver for slotted head screws (slot width 7 mm) so that the planar area [8] of the blade axle becomes parallel to the base plate [7].

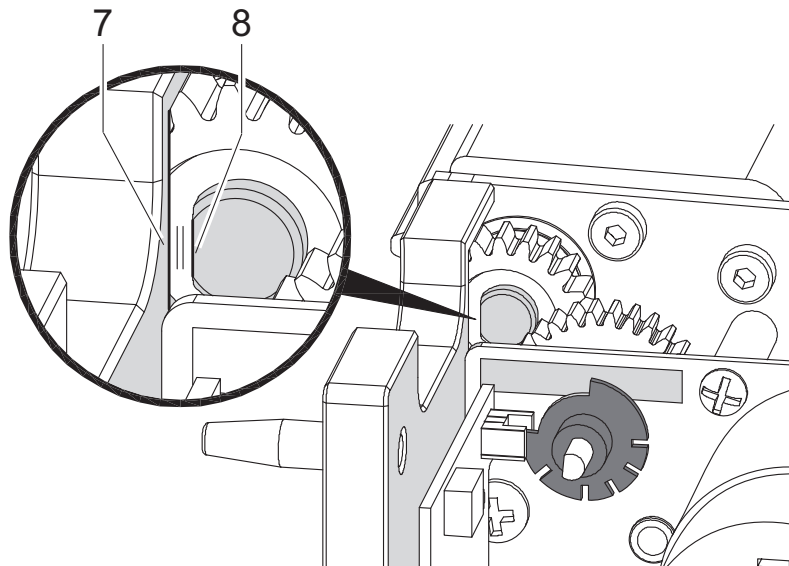

Maintenance

Setting Initial State of the Cutter

4. Check the position of the clock wheel [11].
 - If the clock wheel is in the right position 1, the edge [10] of the clock wheel [11] is located in the area of the marking [9].
 - If clock wheel is in position 2 or 3 turn the circular blade to reach position 1:

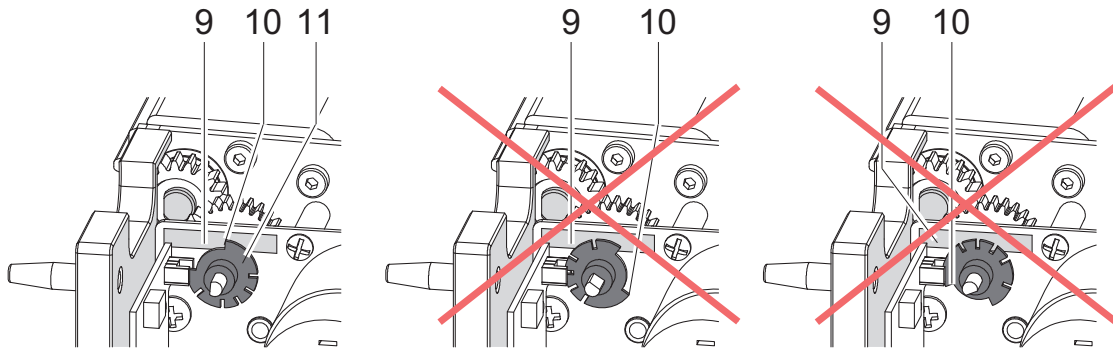

- Loosen screw [12] about 5 mm.
- Turn the circular blade by one or two full turns, until the planar area [8] of the blade axle becomes parallel to the base plate [7] again and the clock wheel reaches the position 1
- Tighten screw [12].

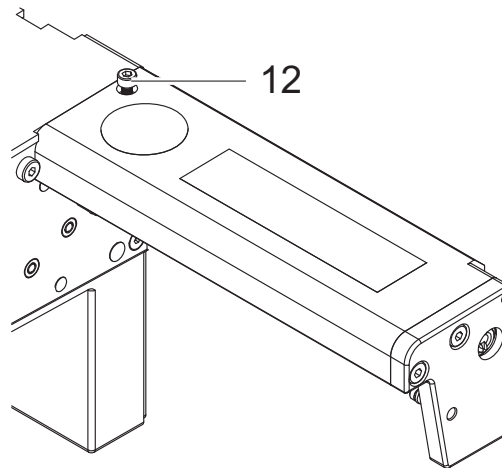

5. Mount the cover.

7 Peripheral Interface

7-1 Pin Assignment

For use in a network environment or with a switch, the auto cutters are equipped with a peripheral interface to allow control of the cutting process.



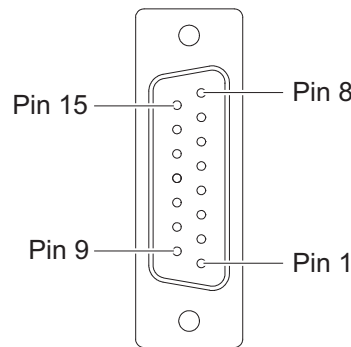





The interface has a 15 pin SUB-D connector [1].







Pin	Signal	Direction	System Function	User function
1	XSTART	Input	Start signal	
2	XFEH	Input	External error	
3	-		-	
4	-	Output	-	Control bit 3
5	XEDG	Output	No existing print job	Control bit 1
6	XDNB	Output	Printer is not ready	Control bit 2
7	XEGES	Output	Print of a label has started	Control bit 0
8	GND	(Output)	Ground (0V)	
9	RXSTART	(Input)	Start signal (reverse line)	
10	RXFEH	(Input)	External error (reverse line)	
11	-		-	
12	GND	(Output)	Ground (0V)	
13	STA	Input	Start signal is active	
14	RUEL	Output	Reverse line (for all output signals)	
15	24P	(Output)	Operating voltage +24V, 100mA	

Note: The description of system functions is included in this manual. For more information about user functions (see Programming Manual, Commands x and X.)

7-2 Explanation of Signals

Pin	Signal	Description	Activation/ Active State
1	XSTART 	Start signal Triggers the start of the print when using the “Cut on demand” operating mode, This signal is checked if there is a connection between signal STA and ground GND.	Switch on +24 V between Pin 1 and Pin 9
2	XFEH 	External error An error has occurred in an externally-controlled device. The label print is stopped and the display of the printer shows the message “External error”. After the error is corrected, it is possible to press the pause key and the print job will continue. The last label printed before the error occurred will be repeated. Pressing the cancel key will stop the print job and the printer will be reset.	Switch on +24 V between Pin 2 and Pin 10
3	-		-
4	-		-
5	XEDG 	No existing print job There is no print job currently available.	Contact between Pin 5 and Pin 14 is open
6	XDNB 	Printer is not ready An error has occurred on the printer. The label print is stopped and the details and type of error can be read from the printer display (‘Ribbon out’; ‘Paper out’; ‘No label’)	Contact between Pin 6 and Pin 14 is open
7	XEDST 	Print of label has started The printing of a label is indicated with a 20 ms pulse.	Contact between Pin 7 and Pin 14 is open
8	GND 	Ground (0 V)	
9	RXSTART 	Start signal (reverse line)	
10	RXFEH 	External error (reverse line)	

Pin	Signal	Description	Activation/ Active State
11	-		-
12	GND 	Ground (0 V)	
13	STA 	Start signal is active The signal enables the “Cut on demand” operating mode. In this case the XSTART signal is checked. With signal STA disabled the cutter is operated in the standard mode.	Connect Pin 13 with Pin 12 (GND)
14	RUEL 	Reverse line for all output signals	
15	24P 	Operating voltage +24 V, 100 mA <hr/>  CAUTION! <i>Output !!!</i> DO NOT connect any external voltage at Pin 15 ! <hr/>	

7-3 Circuit Diagram of Inputs

The XSTART and XFEH inputs are optocouplers with a current limiting resistor of 2.2kΩ giving a voltage of 24V in the input circuit.

For each signal X[IN] there is a separate reverse line X[IN]R via the plug connector. From that, the following matching pairs of signals result :

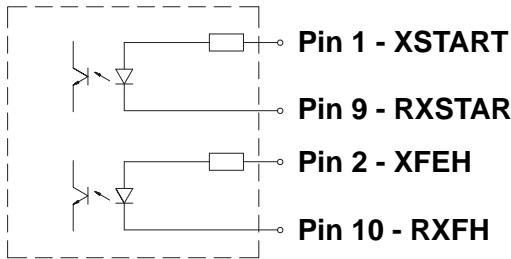

The input signal STA (PIN 13) is connected to GND (PIN 12) for the “Cut on Demand” operating mode.

For external control of cut mode, the connecting device (trigger switch, external control) must be equipped with a 15 pin SUB-D connector.

Example circuit diagram for a trigger switch :

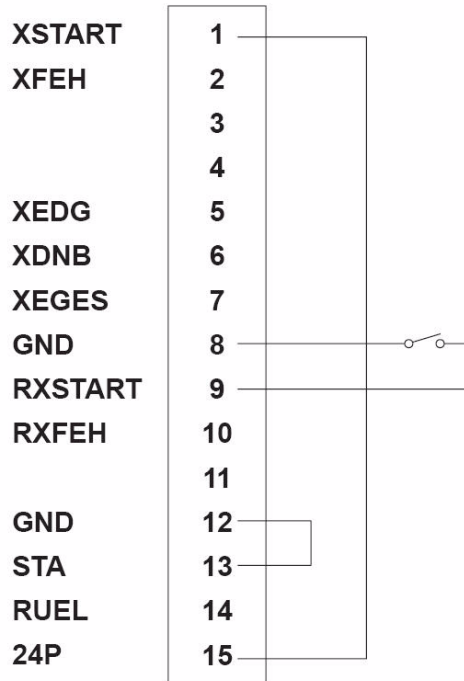

7-4 Circuit Diagram of Outputs

All outputs are established through solid-state relays. The outputs are connected to one another on one-side. The common line leads to the plug connector as a RUEL signal.

The switch function of the outputs is to open or close the contact between the joint line RUEL and the respective output.

Electrical requirements : $U_{\max} = 42 \text{ V}$, $I_{\max} = 100 \text{ mA}$

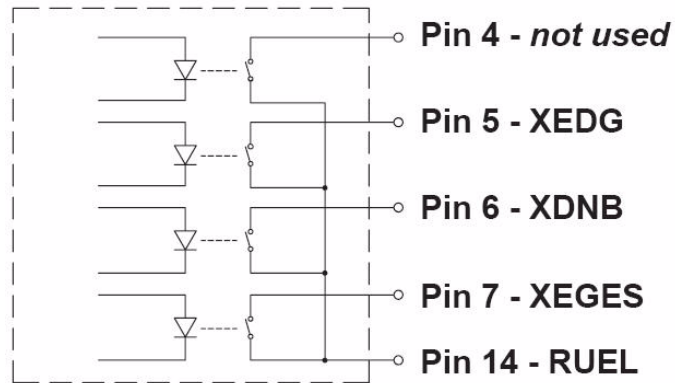

8 Compliance

8-1 UNITED STATES & CANADA

FCC Class A Notice (Printer with Optional Cutters, Type CU X, PCU X)

This device complies with Part 15 of the FCC Rules. Operation is subject to the following two conditions:

1. This device may not cause harmful interference.
2. This device must accept any interference received, including interference that may cause undesired operation.

Note: This equipment has been tested and found to comply with the limits for a Class A digital device, pursuant to Part 15 of the FCC Rules. These limits are designed to provide reasonable protection against harmful interference when the equipment is operated in a commercial environment. This equipment generates, uses, and can radiate radio frequency energy, and if it is not installed and used in accordance with the instruction manual, it may cause harmful interference to radio communications. Operation of this equipment in a residential area is likely to cause harmful interference, in which case the user will be required to correct the interference at his/her own expense.

Modifications: Any modifications made to this device that are not approved by the Brady Corporation may void the authority granted to the user by the FCC to operate this equipment.

ICES-003 Class A Notice, Classe A (Printer with Optional Cutters, Type CU X, PCU X)

This Class A digital apparatus meets all requirements of the Canadian Interference-Causing Equipment Regulations.

Cet appareil numérique de la classe A respecte toutes les exigences du Règlement sur le Matériel Brouilleur du Canada.

Safety Certification (Printer with Optional Cutters, Type CU X, PCU X)

This device complies with the UL60950-1 and CAN/CSA-C22.2 No. 60650-1 standards when used in conjunction with the Brady PR Plus Printer Series.

8-2 EU Conformity Declaration

EU Conformity Declaration

We declare herewith that as a result of the manner in which the device designated below was designed, the type of construction and the devices which, as a result have been brought on to the general market comply with the relevant fundamental regulations of the EU Rules for Safety and Health. In the event of any alteration which has not been approved by us being made to any device as designated below, this statement shall thereby be made invalid.

This declaration is valid only when the cutter is used together with printers of the PR PLUS or BBP72 series. Manufacturer: cab Karlsruhe.

Description	Cutter
Device	CU2, CU2-I, CU4, CU4-ICU6, CU6-I, CU8, CU8-I
Applied EU Regulations	Applied Norms
Directive 2004/108/EC relating to electromagnetic compatibility	<ul style="list-style-type: none"> • EN 55022:2006 • EN 55024:1998+A1:2001+A2:2003 • EN 61000-3-2:2006 • EN 61000-3-3:1995+A1:2001+A2:2005
Signed for, and on behalf of, the Manufacturer :	
cab Produkttechnik Sömmerda Gesellschaft für Computer-und Automationsbausteine mbH99610 Sömmerda	Sömmerda, 17.09.09 Erwin Fascher Managing Director