



## NG Guillotine Cutter Standard and Heavy Duty

USER MANUAL

## Table of Contents

<b>1</b>	<b>Licenses</b> .....	<b>4</b>
1.1	Reference to the EU Declaration of Conformity .....	4
1.2	FCC and Country-Specific Agency Approval Information.....	4
<b>2</b>	<b>Technical Support &amp; Repair</b> .....	<b>5</b>
<b>3</b>	<b>Introduction</b> .....	<b>6</b>
3.1	Instructions.....	6
3.2	Intended Use.....	6
3.3	Safety Instructions.....	7
3.4	Environment.....	7
3.5	Technical Data.....	7
<b>4</b>	<b>Mounting</b> .....	<b>8</b>
4.1	Removing Covers.....	8
4.2	Removing Anti-Static Brush .....	8
4.3	Mounting Cutter.....	9
4.4	Mounting Cutter Tray.....	9
<b>5</b>	<b>Operation</b> .....	<b>10</b>
5.1	Preparation.....	10
5.2	Standard Operation.....	11
5.3	Cutting on Demand .....	11
<b>6</b>	<b>Printer Configuration</b> .....	<b>12</b>
<b>7</b>	<b>Maintenance</b> .....	<b>13</b>
7.1	Removing the Blades for Cleaning and Replacement .....	13
7.2	Lubricating the Blades.....	14
7.3	Reassembling the Blades .....	14
7.4	Calibrating the cutter .....	15
<b>8</b>	<b>Error Messages</b> .....	<b>16</b>

## User Manual for the following products

Model	Configurations
NG Guillotine Cutter	Standard
	Heavy Duty

### Disclaimer

This manual, as well as translation hereof, is proprietary to Brady Worldwide, Inc. (hereafter "Brady"), and may be revised from time to time without notice. Brady disclaims any understanding to provide you with such revisions, if any.

This manual is copyrighted with all rights reserved. No portion of this manual may be copied or reproduced by any means without the prior written consent of Brady.

While every precaution has been taken in the preparation of this document, Brady assumes no liability to any party for any loss or damage caused by errors or omissions or by statements resulting from negligence, accident, or any other cause. Brady further assumes no liability arising out of the application or use of any product or system described, herein; nor any liability for incidental or consequential damages arising from the use of this document. Brady disclaims all warranties of merchantability of fitness for a particular purpose.

Brady reserves the right to make changes without further notice to any product or system described herein to improve reliability, function, or design.

### Trademark

All brand or product names referenced in this manual are trademarks (™) or registered trademarks (®) of their respective companies or organizations. ©2020 Brady Corporation. All rights reserved.

### Editor

Regarding questions or comments please contact Brady Technical Support.

### Topicality

Due to the constant further development of products discrepancies between documentation and product can occur. Please check BradyID.com for the latest update.

### Terms and conditions

Deliveries and performances are effected under the General conditions of sale of Brady.

### Brady Warranty

Our products are sold with the understanding that the buyer will test them in actual use and determine for him or herself their adaptability to his/her intended uses. Brady warrants to the buyer that its products are free from defects in material and workmanship, but limits its obligation under this warranty to replacement of the product shown to Brady's satisfaction to have been defective at the time Brady sold it. This warranty does not extend to any persons obtaining the product from the buyer.

THIS WARRANTY IS IN LIEU OF ANY OTHER WARRANTY, EXPRESS OR IMPLIED, INCLUDING, BUT NOT LIMITED TO, ANY IMPLIED WARRANTY OF MERCHANTABILITY OR FITNESS FOR A PARTICULAR PURPOSE, AND OF ANY OTHER OBLIGATIONS OR LIABILITY ON BRADY'S PART. UNDER NO CIRCUMSTANCES WILL BRADY BE LIABLE FOR ANY LOSS, DAMAGE, EXPENSE OR CONSEQUENTIAL DAMAGES OF ANY KIND ARISING IN CONNECTION WITH THE USE, OR INABILITY TO USE, BRADY'S PRODUCTS.

## 1 Licenses

### 1.1 Reference to the EU Declaration of Conformity

The cutters of the NG series comply with the relevant fundamental regulations of the EU Rules for Safety and Health:

- Directive 2014/30/EU relating to electromagnetic compatibility
- Directive 2011/65/EU on the restriction of the use of certain hazardous substances in electrical and electronic equipment

EU Declaration of Conformity [bradyeurope.com/conformity](http://bradyeurope.com/conformity)

### 1.2 FCC and Country-Specific Agency Approval Information

NOTE : This equipment has been tested and found to comply with the limits for a Class A digital device, pursuant to Part 15 of the FCC Rules. These limits are designed to provide reasonable protection against harmful interference when the equipment is operated in a commercial environment. The equipment generates, uses, and can radiate radio frequency and, if not installed and used in accordance with the instruction manual, may cause harmful interference to radio communications. Operation of this equipment in a residential area is likely to cause harmful interference in which case the user may be required to correct the interference at his own expense. Changes or modifications not expressly approved by the party responsible for compliance could void the user's authority to operate the equipment. This device complies with Part 15 of the FCC Rules. Operation is subject to the following two conditions: (1) This device may not cause harmful interference and, (2) this device must accept any interference received, including interference that may cause undesired operation.

#### Prop 65 Warning Statement

Prop 65 information related to this product is available at [BradyID.com/i7100compliance](http://BradyID.com/i7100compliance).

#### Canada

##### ICES-003 Class A Notice, Classe A

This Class A digital apparatus meets all requirements of the Canadian Interference-Causing Equipment Regulations. Cet appareil numérique de la classe A respecte toutes les exigences du Règlement sur le matériel brouilleur du Canada. CAN ICES-3 (A)/NMB-3(A)



#### Warning!

This is a class A product. In a domestic environment this product may cause radio interference in which case the user may be required to take adequate measures.

---

## 2 Technical Support & Repair

For repair or technical assistance, locate your regional Brady Technical Support office by going to:

- United States: [bradyid.com/techsupport](http://bradyid.com/techsupport)
- Europe: [bradyeurope.com/services](http://bradyeurope.com/services)
- Asia Pacific: [brady.co.uk/landing-pages/global-landing-page](http://brady.co.uk/landing-pages/global-landing-page)
- Australia: [bradyid.com.au/en-au/supportlanding](http://bradyid.com.au/en-au/supportlanding)
- Canada: [bradycanada.ca](http://bradycanada.ca)
- Latin America: [bradylatinamerica.com](http://bradylatinamerica.com)

### Registration Information

To register your printer go to:

- [bradycorp.com/register](http://bradycorp.com/register)

### Repair and Return

If for any reason you need to return the product for repair, please contact Brady Technical Support for repair and replacement information.

## 3 Introduction

### 3.1 Instructions

Important information and instructions in this documentation are designated as follows:



#### **Danger!**

Draws attention to an exceptionally great, imminent danger to your health or life due to hazardous voltages.



#### **Danger!**

Draws attention to danger with high risk which, if not avoided, may result in death or serious injury.



#### **Warning!**

Draws attention to danger with medium risk which, if not avoided, may result in death or serious injury.



#### **Caution!**

Draws attention to danger with low risk which, if not avoided, may result in minor or moderate injury.



#### **Attention!**

Draws attention to potential risks of property damage or loss of quality.



#### **Note!**

Advice to make work routine easier or on important steps to be carried out.



#### **Environment!**

Gives you tips on protecting the environment.



Handling instruction



Reference to section, position, illustration number or document.



Option (accessories, peripheral equipment, special fittings).

Time Information in the display.

### 3.2 Intended Use

- The device is intended exclusively as an option for the i7100 printer in the basic version for cutting suitable materials. Any other use or use going beyond this shall be regarded as improper use. The manufacturer/supplier shall not be liable for damage resulting from unauthorized use; the user shall bear the risk alone.
- Usage for the intended purpose also includes complying with that manual.
- The device is manufactured in accordance with the current technological status and the recognized safety rules. However, danger to the life and limb of the user or third parties and/or damage to the device and other tangible assets can arise during use.
- The device may only be used for its intended purpose and if it is in perfect working order, and it must be used with regard to safety and dangers as stated in that manual.



#### **Attention!**

For using the cutter the printer firmware version 5.29 or higher is needed.



#### **Note!**

All documentations can also currently be found in the Internet.



#### **Warning!**

This is a class A product. In a domestic environment this product may cause radio interference in which case the user may be required to take adequate measures.

### 3 Introduction

#### 3.3 Safety Instructions

- Disconnect the printer from the electrical outlet before mounting or removing the cutter.
- The cutter may only be operated when it is mounted on the printer.
- Risk of injury, particularly during maintenance, the cutter blades are sharp.
- Work going beyond this may only be performed by trained personnel or service technicians.
- Unauthorized interference with electronic modules or their software can cause malfunctions. Other unauthorized work on or modifications to the device can also endanger operational safety.
- Always have service work done in a qualified workshop, where the personnel have the technical knowledge and tools required to do the necessary work.
- Warning stickers must not be removed, as then you and other people cannot be aware of dangers and may be injured.



**Danger!**  
**Danger to life and limb from power supply.**  
 ► Do not open the device casing.

#### 3.4 Environment



Obsolete devices contain valuable recyclable materials that should be sent for recycling.

- Send to suitable collection points, separately from residual waste.

The modular construction of the device enables it to be easily disassembled into its component parts.

- Send the parts for recycling.
- Take the electronic circuit boards to public waste disposal centers or to the distributor.

#### 3.5 Technical Data

Technical data for printer type		NG Guillotine Cutter			
		Standard		Heavy Duty	
		i7100		i7100	
Material width	up to mm	120	114	120	114
weight cardboard	up to g/m <sup>2</sup>	200		300	
thickness	up to mm	1,1		1,5	
Cutting length	from mm	10		10	
Gap height	up to mm	2,5		2,5	
Cut frequency	about cuts/min.	120		60	
Cutter Tray for Cutting length	up to mm	100		100	
Monitoring		End position of the blade not reached Blade is swung off Blade cover removed			



**Attention!**  
 The minimum cut length is depending on the media, in particular its adhesive characteristics.  
 ► Perform preliminary tests. Test the media too, if the media is very hard, very flexible or very thin.

## 4 Mounting

### 4.1 Removing Covers

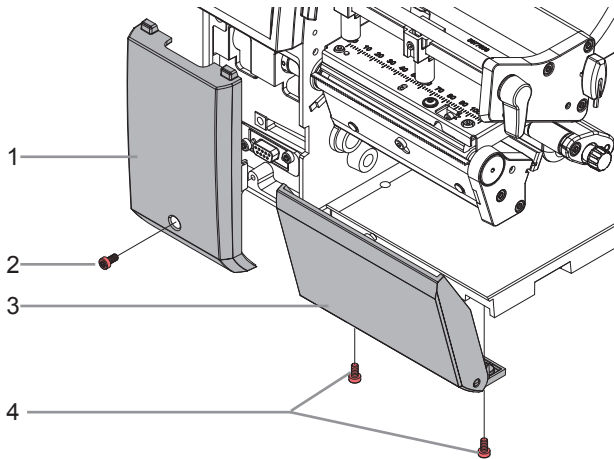

- ▶ Loosen screw (2) and remove cover (1).
- ▶ Loosen screws (4) and remove cover (3).

### 4.2 Removing Anti-Static Brush

The anti-static brush neutralizes the buildup of excess static electricity from the printer / printhead area. If the anti-static brush will be used, please be sure to use part number 170345 which is compatible with the cutter. This may require replacing the anti-static brush that came with the product.

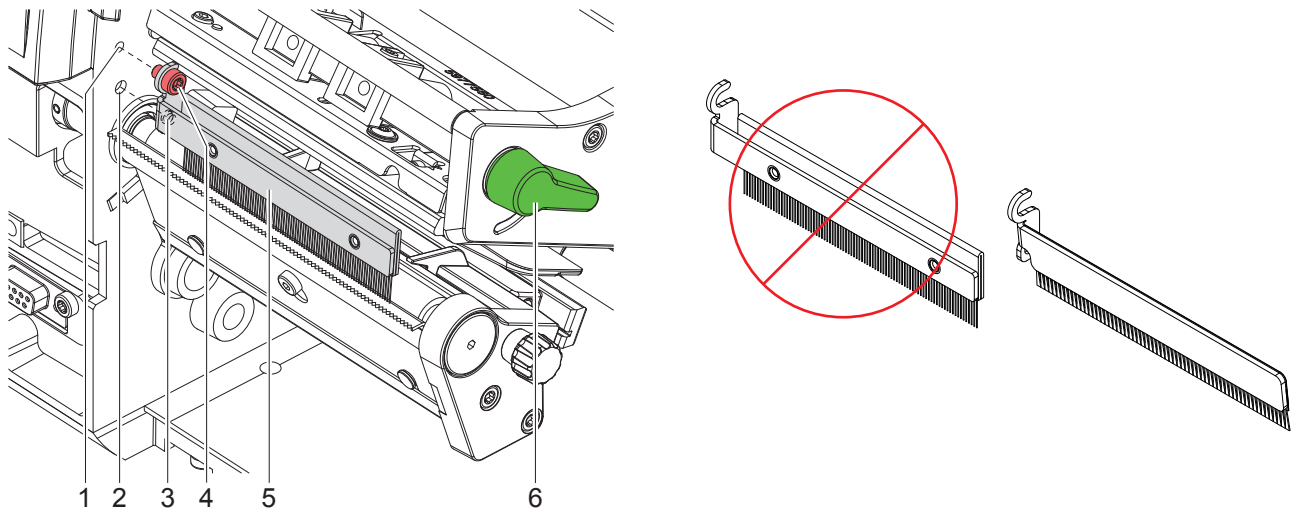

- ▶ Turn lever (6) counterclockwise to open the printhead.
- ▶ Remove the anti-static brush (5) from the printer by removing the screw (4) via the threaded hole (1).
- ▶ Ensure that the embossing (3) un-snaps from its counterpart (2) when loosening the screw.
- ▶ Close the printhead.



#### Attention!

For cutter operation there has to be mounted a tear-off plate or a dispense plate on the printer, to lead the material through the blades of the cutter.



## 4 Mounting

### 4.3 Mounting Cutter

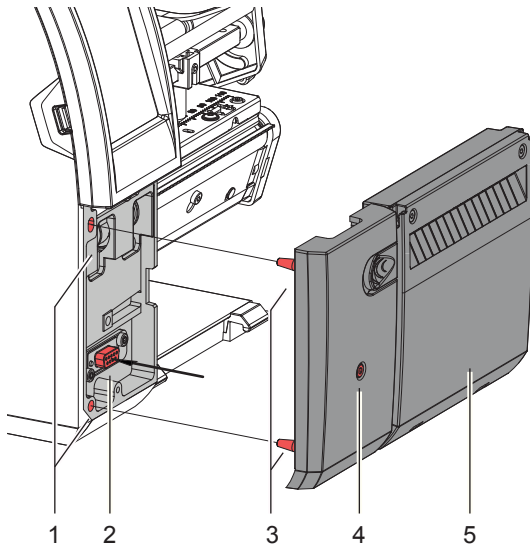

- ▶ Insert the pins (3) of the cutter (5) into the holes (1) of the printer.
- ▶ Press the cutter against the printer. That way the plug of the cutter will be connected to the peripheral port (2) of the printer.
- ▶ Secure the cutter (5) with the screw (4).

### 4.4 Mounting Cutter Tray

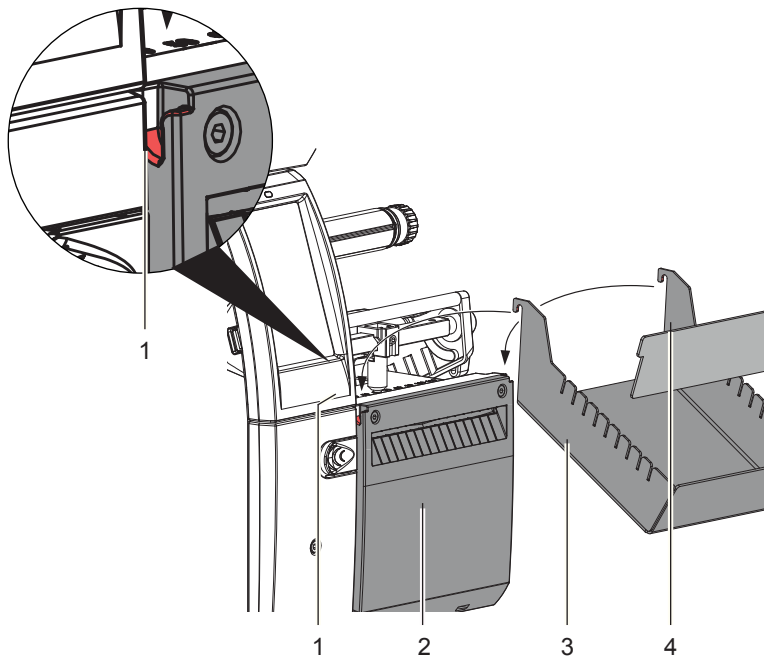

- ▶ Hook the cutter tray box (3) with the fixing brackets into the recesses (1) on the mounted cutter (2).
- ▶ Slide the divider (4) according to the label height into the corresponding groove in the cutter tray box. This ensures a correct stacking of the cut labels.

## 5 Operation

### 5.1 Preparation

- ▶ Slide lever to the left to fold down the cutter unit.

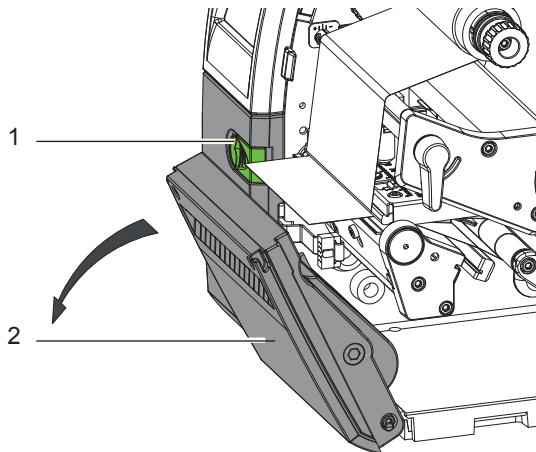

- ▶ Insert labels for tear-off mode ▷ Instructions of the printer.  
Place the media strip between the printhead and the drive roller, so that the front edge of the strip reaches through the cutter.
- ▶ Insert ribbon ▷ Instructions of the printer.
- ▶ Fold up and lock the cutter unit (2).
- ▶ Activate the cut mode in the software.  
In direct programming use the "C" command.  
▷ Programming Manual of the printer.
- ▶ Configure the cut parameters ▷ 6 Printer Configuration.

**Note!**

The cut parameters are only accessible with cutter installed.

## 5 Operation

### 5.2 Standard Operation

- ▶ Switch on the printer.  
The cutter performs a synchronization action.



**Note!**

**To operate the cutter with continuous material in the printer menu Setup -> Labels -> Label sensor the setting Continuous media has to be selected. Otherwise no synchronization cut is carried out.**

- ▶ Press . For synchronization the media will be moved forward and cut off.  
That synchronization is not necessary when the printhead was not opened between print jobs, even if the printer was powered off between print jobs.
- ▶ Send a print job.  
All labels in the job will be printed without stopping and be cut as chosen in the software : after each label, after a specific quantity of labels, or at the end of a print job.



**Note!**

**Between the print jobs a direct cut can be released by pressing  on the control panel.**





**Note!**

**In case the material do adhere in follow of electrostatic charge it's possible to mount an antistatic brush (Part No. 170345) on the printer.**

### 5.3 Cutting on Demand

In the "Cut on Demand" mode the print job will be split into steps, which can be released separately.

- ▶ Choose Printing > Print on demand = On.  
▷ 6 Printer Configuration.
- ▶ Send a print job.
- ▶ Press .  
The first label will be printed and cut.
- ▶ Press  again to print and cut the next label.



**Note!**

**The  function can be released alternatively by an external START signal when the I/O interface is installed on the printer.**

▷ **Configuration Manual of the printer.**

## 6 Printer Configuration



**Note!**

The values of the setup are basic settings for the current printer/cutter combination. After changing the cutter or printer a re-adjustment may be necessary.

Changes required for processing different print jobs should be implemented by additional offsets available in the software.

The offset values from setup and software are added together for execution.



For detailed instructions for configuration

▷ **Configuration Manual of the printer.**

**Cut Parameters**

▶ Start menu.

▶ Select  Setup >  Cutting.

Parameter	Meaning	Default
 Device info	Information to the device: Software version, counts of cuts and errors	
 Calibrate device	Calibration of the lower blade end position. ▷ 7.4 Calibrating the cutter	
 Cut position	Offset of the cut position relative to the rear label edge. The setting can also be adjusted by the software. The settings of configuration and software are added together.	0.0 mm

**Label Sensor**

▶ Start menu.

▶ Select  Setup >  Labels.

Parameter	Meaning	Default
 Label sensor	Method for detecting the starting end of the label. Gap Sensor: Detection using changes in the transparency between the label and label gap. Bottom-Reflect: Detection using reflex marks on the bottom of the medium. Continuous media: Checking the existence of media only.	Gap sensor

**Backfeed**

▶ Start menu.

▶ Select  Setup >  Printing.

Parameter	Meaning	Default
 Backfeed	Method for backfeeding the label medium. Backfeeding is necessary in the cutting and peel-off modes since a label is pushed out passed the front edge of the next label above the print line when peeling off/cutting. always: Backfeeding occurs independently of label contents. smart: Backfeeding only occurs when the next label is not yet completely prepared when peeling off/cutting the current label. Otherwise, the second label is pushed on and completed after removal of the first label without backfeeding.	smart

## 7 Maintenance

### 7.1 Removing the Blades for Cleaning and Replacement



#### Warning!

Disconnect the printer from the electrical outlet.



#### Caution!

Risk of injury. The cutter blades are sharp.

To clean the blades, they must be removed.

1. Disassemble the NG Guillotine Cutter from the printer.

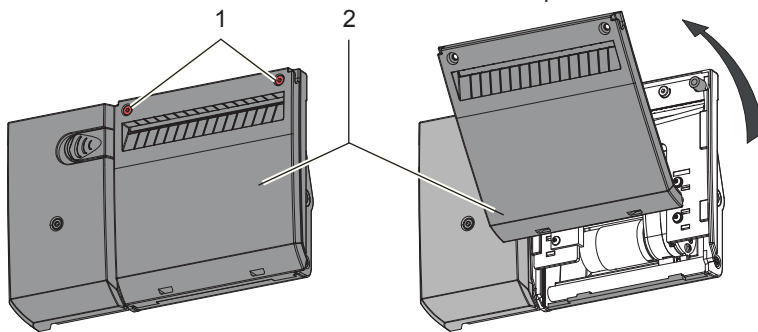

2. Loosen screws (1) and remove cover (2) towards the front.

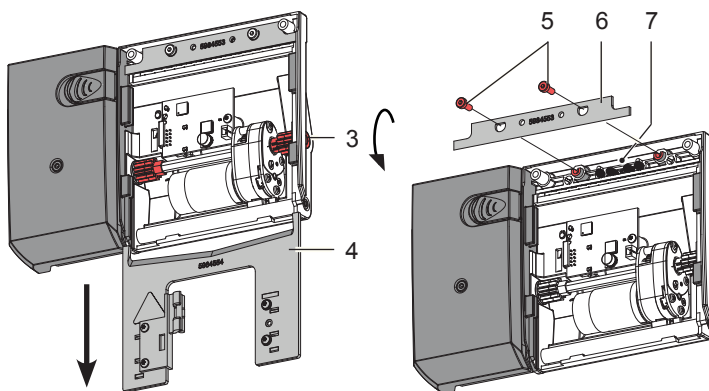

3. Using a 2.5mm hex wrench to turn the axle (3) counterclockwise. The lower blade (4) is moved down until it can be pulled out.
4. Loosen screws (5).
5. Fix the upper blade (6) while the springs (7) press against the upper blade (6). Remove the upper blade (6) and make sure that the springs (7) do not fall out.

## 7 Maintenance

### 7.2 Lubricating the Blades



**Note!**

When cutting through the label material instead of the label gap remains of adhesive may accumulate on the blades. If operating in backfeed mode, such remains of adhesive may be deposited on the drive roller as well.

- ▶ Clean often the drive roller (▷ Printer Instructions) and the cutter blades.

For a perfect function of the cutter, it is necessary to grease the blades and guides at selected areas. After each cleaning and before installing new blades, grease must be applied.



**Attention!**

Use only a plastic grease to grease the blades and running surfaces.

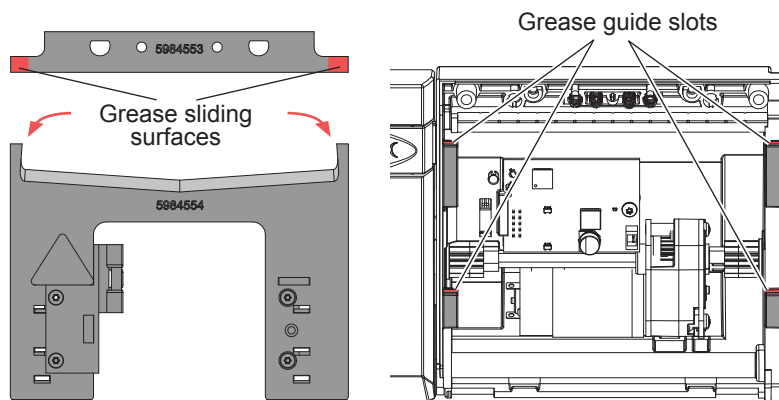

### 7.3 Reassembling the Blades

The assembly of the cleaned or new blades and the assembly of the cutter is carried out in the reverse order of disassembly.

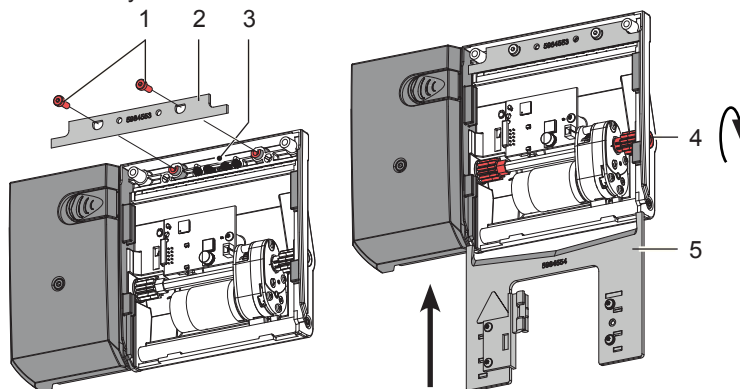

- ▶ Put on the upper blade(2) and make sure that the springs (3) should not be kinked and remain in the guides
- ▶ Fix the upper blade (2) with the screws (1).
- ▶ Push the lower blade (5) in the guides upward until the toothed rail on the upper blade (5) pushes against the gear wheels on the axle (4). Then turn the axle (4) clockwise with a 2.5 mm hex wrench until the lower blade (5) is just before the upper blade (2).

## 7 Maintenance

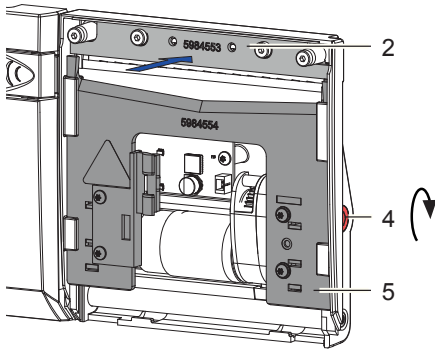



- ▶ Press the upper blade (2) inwardly and slide the lower blade (5) over the upper blade (2) by turning the axle (4) clockwise to the maximum top.
  - ▶ Mount the cover and attach the cutter to the printer.
- After turning on the printer, the lower blade automatically aligns.

### 7.4 Calibrating the cutter



#### Attention!

After every blade change and removal and installation of the blades for cleaning, the blades must be calibrated!

- ▶ Remove label material.
- ▶ Start menu.
- ▶ Select  Setup >  Cutting >  Calibrate device.
- ▶ Press Continue to start the calibration process.  
After a cutter movement the display shows *Device successfully calibrated*.  
If the calibration failed an error message will appear.
- ▶ Select Continue.

## 8 Error Messages

Error message	Cause	Remedy
<i>Cutter blocked</i>	The media cannot be cut and the blades cannot return in the home position.	<ul style="list-style-type: none"> <li>▶ Switch off the printer.</li> <li>▶ Remove trapped material.</li> <li>▶ Switch on the printer.</li> <li>▶ New start of the print job. Change material.</li> </ul>
	Cutter is without function.	<ul style="list-style-type: none"> <li>▶ Switch off and on the printer.</li> <li>▶ If it does occur again, contact service.</li> </ul>
<i>Cutter cover open</i>	Cover of cutter is not mounted.	▶ Mount the cover
<i>Device not locked</i>	Cutter is not in operating position.	▶ Fold up and lock the cutter unit.
	Tear-off Plate not mounted.	▶ Mount the Tear-off Plate.
<i>Device too hot</i>	Temperature of the cutter is not in the allowed range.	▶ Let cool down the cutter.
<i>Media too thick</i>	The media cannot be cut but the blades can return in the home position.	<ul style="list-style-type: none"> <li>▶ Press Cancel.</li> <li>▶ Change material.</li> </ul>

Warning message	Cause	Remedy
<i>Blades dirty or worn out</i>	Cleaning or blade-replacing necessary.	<ul style="list-style-type: none"> <li>▶ Clean the blades.</li> <li>▶ Change the blades.</li> </ul>

Warning messages can be acknowledged with Next and the printing and cutting process will be continued.



This page intentionally left blank.



**Brady Worldwide, Inc**  
6555 West Good Hope Road  
Milwaukee, WI 53223  
[bradyid.com](http://bradyid.com)

**Brady EMEA**  
Lindestraat 20  
9240 Zele  
Belgium  
[bradycorp.com/global](http://bradycorp.com/global)

**Brady Corporation Asia**  
1 Kaki Bukit Crescent  
Singapore 416236  
[bradycorp.com/global](http://bradycorp.com/global)