

Vial Label Applicator for BradyPrinter i7100

USER MANUAL

Table of Contents

1	Licenses	4
1.1	Reference to the EU Declaration of Conformity	4
1.2	FCC and Country-Specific Agency Approval Information	4
2	Technical Support & Repair	5
3	Application Engineering Services	6
4	Introduction	7
4.1	Instructions	7
4.2	Intended Use	7
4.3	Safety Instructions	8
4.4	Environment	8
5	Mounting	9
5.1	Removing the Cover	9
5.2	Replacing the Printer Roller	9
5.3	Replacing the Dispense Plate	10
5.4	Mounting the Applicator	10
5.5	Mounting the Tray	11
6	Settings	12
6.1	Adjusting the Swing Arms	12
6.2	Adjusting the Pressure Rollers	13
6.3	Adjusting the Transport Rollers	13
6.4	Printer Configuration	14
7	Operation	15
7.1	Preparation	15
7	Operation	16
7.2	Standard Operation	16
8	Fault Correction	17

Disclaimer

This manual, as well as translation hereof, is proprietary to Brady Worldwide, Inc. (hereafter "Brady"), and may be revised from time to time without notice. Brady disclaims any understanding to provide you with such revisions, if any.

This manual is copyrighted with all rights reserved. No portion of this manual may be copied or reproduced by any means without the prior written consent of Brady.

While every precaution has been taken in the preparation of this document, Brady assumes no liability to any party for any loss or damage caused by errors or omissions or by statements resulting from negligence, accident, or any other cause. Brady further assumes no liability arising out of the application or use of any product or system described, herein; nor any liability for incidental or consequential damages arising from the use of this document. Brady disclaims all warranties of merchantability of fitness for a particular purpose.

Brady reserves the right to make changes without further notice to any product or system described herein to improve reliability, function, or design.

Trademark

All brand or product names referenced in this manual are trademarks (™) or registered trademarks (®) of their respective companies or organizations. ©2020 Brady Corporation. All rights reserved.

Editor

Regarding questions or comments please contact Brady Technical Support.

Topicality

Due to the constant further development of products discrepancies between documentation and product can occur. Please check BradyID.com for the latest update.

Terms and conditions

Deliveries and performances are effected under the General conditions of sale of Brady.

Brady Warranty

Our products are sold with the understanding that the buyer will test them in actual use and determine for him or herself their adaptability to his/her intended uses. Brady warrants to the buyer that its products are free from defects in material and workmanship, but limits its obligation under this warranty to replacement of the product shown to Brady's satisfaction to have been defective at the time Brady sold it. This warranty does not extend to any persons obtaining the product from the buyer.

THIS WARRANTY IS IN LIEU OF ANY OTHER WARRANTY, EXPRESS OR IMPLIED, INCLUDING, BUT NOT LIMITED TO, ANY IMPLIED WARRANTY OF MERCHANTABILITY OR FITNESS FOR A PARTICULAR PURPOSE, AND OF ANY OTHER OBLIGATIONS OR LIABILITY ON BRADY'S PART. UNDER NO CIRCUMSTANCES WILL BRADY BE LIABLE FOR ANY LOSS, DAMAGE, EXPENSE OR CONSEQUENTIAL DAMAGES OF ANY KIND ARISING IN CONNECTION WITH THE USE, OR INABILITY TO USE, BRADY'S PRODUCTS.

1 Licenses

1.1 Reference to the EU Declaration of Conformity

The Vial Label Applicator complies with the relevant fundamental regulations of the EU Rules for Safety and Health:

- Directive 2006/42/EC on machinery
- Directive 2014/30/EU relating to electromagnetic compatibility
- Directive 2011/65/EU on the restriction of the use of certain hazardous substances in electrical and electronic equipment

EU Declaration of Conformity bradyeurope.com/conformity

1.2 FCC and Country-Specific Agency Approval Information

NOTE : This equipment has been tested and found to comply with the limits for a Class A digital device, pursuant to Part 15 of the FCC Rules. These limits are designed to provide reasonable protection against harmful interference when the equipment is operated in a commercial environment. The equipment generates, uses, and can radiate radio frequency and, if not installed and used in accordance with the instruction manual, may cause harmful interference to radio communications. Operation of this equipment in a residential area is likely to cause harmful interference in which case the user may be required to correct the interference at his own expense. Changes or modifications not expressly approved by the party responsible for compliance could void the user's authority to operate the equipment. This device complies with Part 15 of the FCC Rules. Operation is subject to the following two conditions: (1) This device may not cause harmful interference and, (2) this device must accept any interference received, including interference that may cause undesired operation.

Prop 65 Warning Statement

Prop 65 information related to this product is available at BradyID.com/i7100compliance.

Canada

ICES-003 Class A Notice, Classe A

This Class A digital apparatus meets all requirements of the Canadian Interference-Causing Equipment Regulations. Cet appareil numérique de la classe A respecte toutes les exigences du Règlement sur le matériel brouilleur du Canada. CAN ICES-3 (A)/NMB-3(A)



Warning!

This is a class A product. In a domestic environment this product may cause radio interference in which case the user may be required to take adequate measures.

2 Technical Support & Repair

For repair or technical assistance, locate your regional Brady Technical Support office by going to:

- United States: bradyid.com/techsupport
- Europe: bradyeurope.com/services
- Asia Pacific: brady.co.uk/landing-pages/global-landing-page
- Australia: bradyid.com.au/en-au/supportlanding
- Canada: bradycanada.ca
- Latin America: bradylatinamerica.com

Registration Information

To register your printer go to:

- bradycorp.com/register

Repair and Return

If for any reason you need to return the product for repair, please contact Brady Technical Support for repair and replacement information.

3 Application Engineering Services

Application Engineering Services

Brady offers fee-based application engineering services in some locations. If you need assistance with advanced integration of your Vial Label Applicator into a complex data flow scenario that is not supported under normal tech support capabilities, Brady's Application Engineering Team may be able to help. This team specializes in customized fee-based services that include:

- Custom software programming
- Custom front-end application software programming
- Software template creation
- Label file conversion
- Scan-to-print mapping assistance
- Advanced integration of printer & data flow



Note!

Application Engineering Services is not available in all Brady locations - contact the applications engineering email below or contact your local Brady Tech Support location for availability of these services in your area.

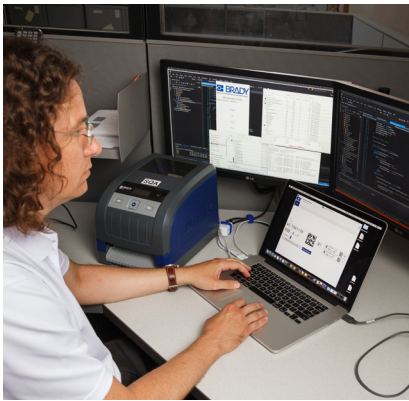

Application Engineering Services

Advanced integration and custom programming services to solve complex dataflow scenarios integrating printers, software, data collection devices and databases.

Contacting Brady Application Engineering

Contact Brady Application Engineering via email at application_engineering@bradycorp.com to discuss your application, or to learn about the availability of services in your location.

4 Introduction

4.1 Instructions

Important information and instructions in this documentation are designated as follows:



Danger!

Draws attention to an exceptionally great, imminent danger to your health or life due to hazardous voltages.



Danger!

Draws attention to danger with high risk which, if not avoided, may result in death or serious injury.



Warning!

Draws attention to danger with medium risk which, if not avoided, may result in death or serious injury.



Caution!

Draws attention to danger with low risk which, if not avoided, may result in minor or moderate injury.



Attention!

Draws attention to potential risks of property damage or loss of quality.



Note!

Advice to make work routine easier or on important steps to be carried out.



Environment!

Gives you tips on protecting the environment.



Handling instruction



Reference to section, position, illustration number or document.



Option (accessories, peripheral equipment, special fittings).

Time Information in the display.

4.2 Intended Use

- The device is intended exclusively as an option for the BradyPrinter i7100 series peel model printers. Any other use or use going beyond this shall be regarded as improper use. The manufacturer/supplier shall not be liable for damage resulting from unauthorized use; the user shall bear the risk alone.
- Usage for the intended purpose also includes complying with that manual.
- The device is manufactured in accordance with the current technological status and the recognized safety rules. However, danger to the life and limb of the user or third parties and/or damage to the device and other tangible assets can arise during use.
- The device may only be used for its intended purpose and if it is in perfect working order, and it must be used with regard to safety and dangers as stated in that manual.



Note!

All documentations can also currently be found in the Internet.

4 Introduction

4.3 Safety Instructions

- Disconnect the printer from the electrical outlet before mounting or removing the applicator.
- The applicator may only be operated when it is mounted on the printer.
- Work going beyond this may only be performed by trained personnel or service technicians.
- Unauthorized interference with electronic modules or their software can cause malfunctions. Other unauthorized work on or modifications to the device can also endanger operational safety.
- Always have service work done in a qualified workshop, where the personnel have the technical knowledge and tools required to do the necessary work.



Danger!

Danger to life and limb from power supply.

- ▶ **Do not open the device casing.**

4.4 Environment



Obsolete devices contain valuable recyclable materials that should be sent for recycling.

- ▶ Send to suitable collection points, separately from residual waste.

The modular construction of the device enables it to be easily disassembled into its component parts.

- ▶ Send the parts for recycling.
- ▶ Take the electronic circuit boards to public waste disposal centers or to the distributor.

5 Mounting



Attention!

- ▶ Disconnect the printer from the electrical outlet before mounting the scanner.

5.1 Removing the Cover

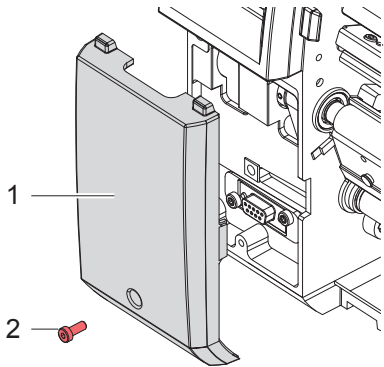

- ▶ Loosen screw (2) and remove cover (1).

5.2 Replacing the Printer Roller

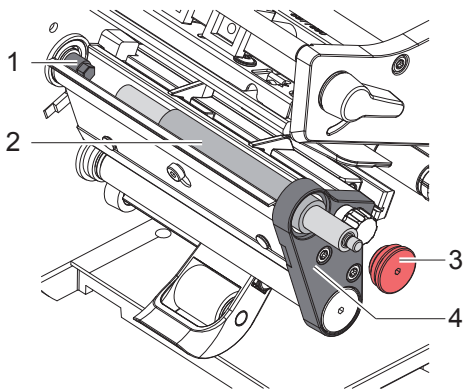

- ▶ Remove the roller bearing (3) with the 2.5 mm Allen key out of the side plate (4).
- ▶ Pull the original print roller from the shaft (1) through the side plate (4).
- ▶ Insert the new roller (2) and slide it onto the shaft(1). Turn the roller slightly until the hexagonal shaft engages the hexagonal socket of the roller.
- ▶ Put the roller bearing (3) onto the axle of the roller and screw it into the side plate (4).



Attention!

- ▶ Be certain the roller bearing is sitting cleanly in the side plate; do not allow bearing to cross-thread! If bearing does not screw smoothly into side plate, remove it and start again.

5 Mounting

5.3 Replacing the Dispense Plate

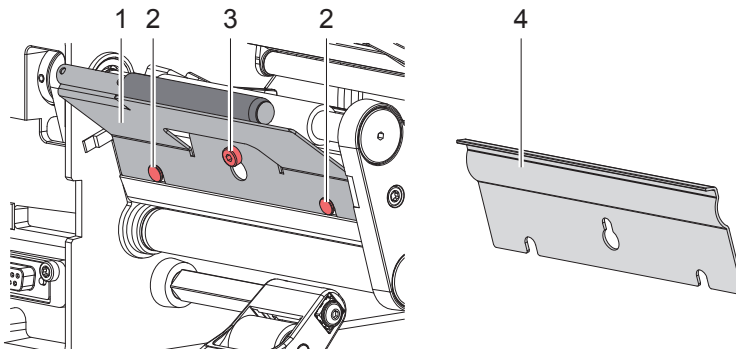

- ▶ Loosen the screw (3) several turns.
- ▶ Slide the original dispense plate (4) upwards and remove it.
- ▶ Place dispense plate of the applicator (1) onto the screw (3) and slide it downwards behind the pins (2).
- ▶ Tighten the screw (3).

5.4 Mounting the Applicator

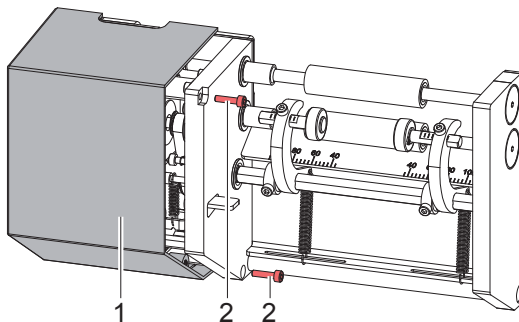

- ▶ Loosen two screws (2) and remove the cover (1).

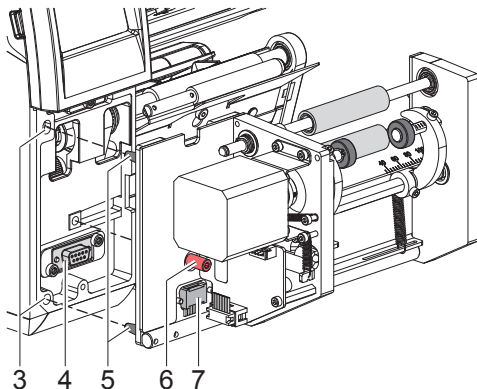

- ▶ Insert the pins (5) of the applicator into the holes (3) of the printer.
- ▶ Press the applicator against the printer. That way the plug (7) will be connected to the peripheral port (4) of the printer.
- ▶ Secure the applicator with the screw (6).
- ▶ Mount the cover of the applicator.

5 Mounting

5.5 Mounting the Tray

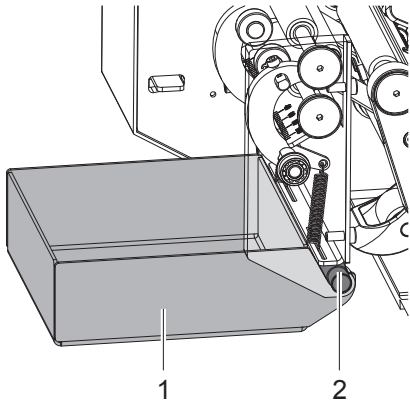

- ▶ Push the tray (1) under the applicator and fit it at the axle (2).

6 Settings

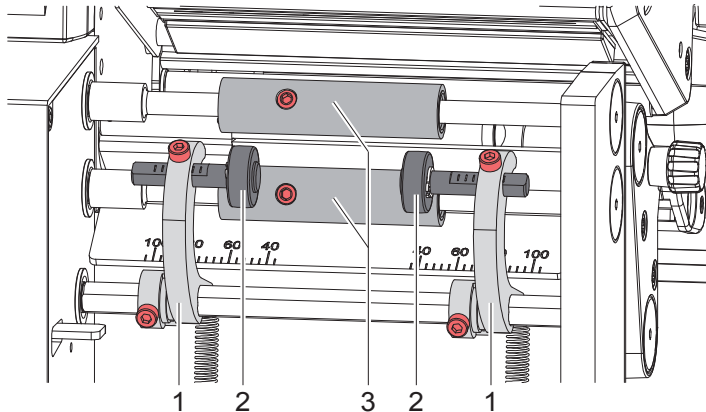

The applicator can be adjusted as follows:

- Adjusting the swing arms (1) to adapt the applicator to the length of the tube and the positioning of the label ▷ 6.1 on page 12
- Adjusting the pressure rollers (2) for guiding the cap or thread of the tube ▷ 6.2 on page 13
- Adjusting the transport rollers (3) for guiding the cap or thread of the tube ▷ 6.3 on page 13
- Teaching the applicator to the tube diameter ▷ 6.4 on page 14
- Setting further labelling parameters ▷ 6.4 on page 14

6.1 Adjusting the Swing Arms

The positioning of the swing arms is depending on the following dimensions:

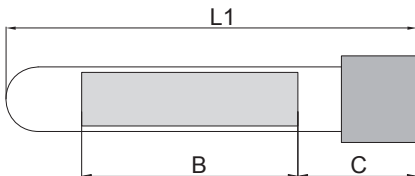

- L1 - Length of the tube
- B - Width of the label
- C - Distance of the label to the upper edge of the tube

On the applicator there is a scale (1) to position the swing arms.

- If dimension C is not defined the edges P1 and P2 can be set to the value L1.
- If dimension C is defined both swing arm must be displaced by the value $V = 2 \cdot C + B - L1$

From this follow the settings:

Cap side: $P1 = L1 + V$

other side: $P2 = L1 - V$

Example:

$L1 = 76, B = 40, C = 22 \rightarrow V = 8, P1 = 84, P2 = 68$

6 Settings

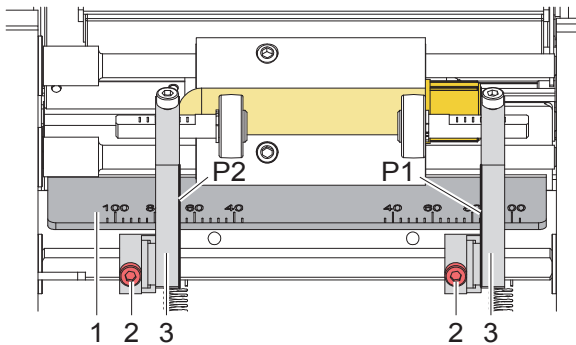

- ▶ Loosen the screws (2), shift the swing arms (3) to the positions P1 and P2 and tighten the screws.

6.2 Adjusting the Pressure Rollers

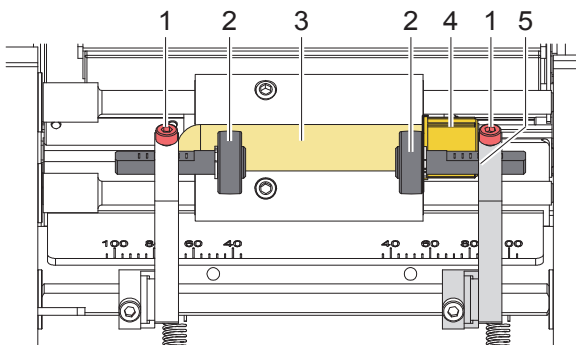

- Move the pressure roller at the cap side to such a position that the cap (4) will be guided by the swing arm (5) and the pressure roller (2).
- Adjust the pressure roller at the other side to the cylindrical zone of the tube (3).
- ▶ Loosen the screws (1), shift the holders of the pressure rollers (2) sideways and tighten the screws

6.3 Adjusting the Transport Rollers

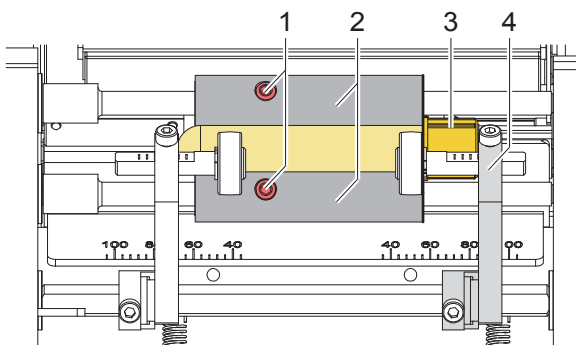

- Move the transport rollers to such a position that the cap (3) will be guided by the swing arm (4) and the transport rollers (2).
- ▶ Loosen the screws (1), shift the transport rollers (2) sideways on the axles and tighten the screws

6 Settings





6.4 Printer Configuration



Note!

In that chapter are described the specific applicator parameters of the menu *Labelling* only. For more information about the configuration ► **Configuration Manual** of the printer.

- Start menu.
- Select *Setup > Labelling*.

Parameter	Meaning	Default
 <i>Peel-off position</i>	Shift the position of the dispensed label relative to the dispensing edge. The setting can also be adjusted by the software. The settings of configuration and software are added together.	<i>0.0 mm</i>
 <i>Teach-in product</i>	Function to teach the applicator the tube diameter.	
 <i>Eject tube</i>	<i>Off</i> : The tube will be ejected after labelling <i>On</i> : The tube will be left in the labelling area after labelling	<i>Off</i>
 <i>Opening width</i>	Setting the distance between the transport rollers and pressure rollers for tube input	<i>1</i>
 <i>Check diam.</i>	Checking the tube diameter before labelling	<i>Off</i>

Teach-in product

- Select *Teach-in product*.
The display shows *Step 1/2 Remove tube*.
- Remove the tube from the applicator and select *Continue*.
After a short applicator movement the display shows *Step 2/2 Insert tube*.
- Insert a tube and select *Continue*.
After a next applicator movement the display shows *Product successfully taught-in*.
If the result is out of the specification an error message will appear.
- Select *Continue*.

7 Operation

7.1 Preparation

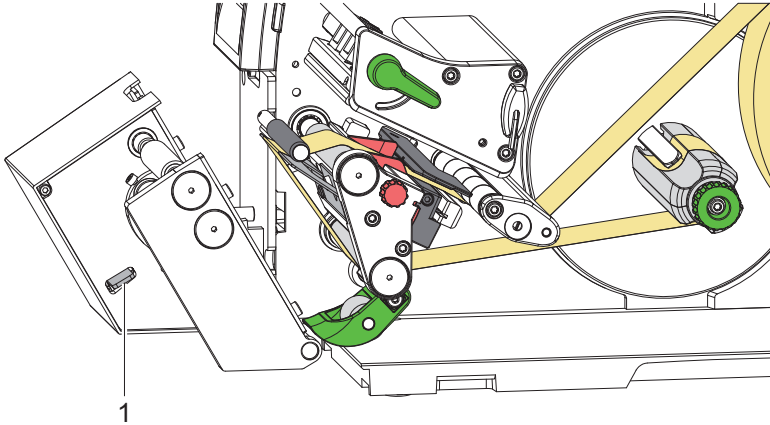

- ▶ Press down the locking lever (1) to unlock the applicator.
- ▶ Fold down the applicator.
- ▶ Load labels as shown the figure ▶ refer to Instructions of the printer for media strip rewind mode.
- ▶ Load transfer ribbon ▶ refer to Instructions of the printer.
- ▶ Fold up the applicator and press it against the printer.
The applicator will be locked automatically.
- ▶ Activate the peel-off mode in the software.
In direct programming use the "P" command.
▶ Programming Manual of the printer.
- ▶ Configure the labelling parameters ▶ 6.4. Printer Configuration

7 Operation

7.2 Standard Operation



Warning!

Risk of injury by rotating parts!

During operation, rotating parts are freely accessible.

Ensure that people's clothing, hair, jewelry etc. do not come into contact with the exposed rotating parts.

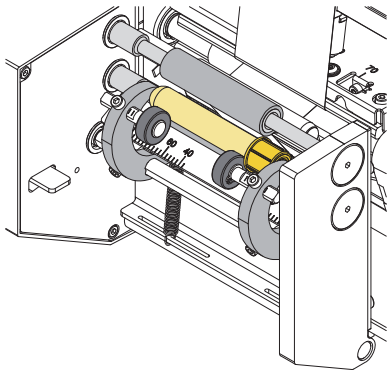

- ▶ Send a print job.
- ▶ Insert the first tube.

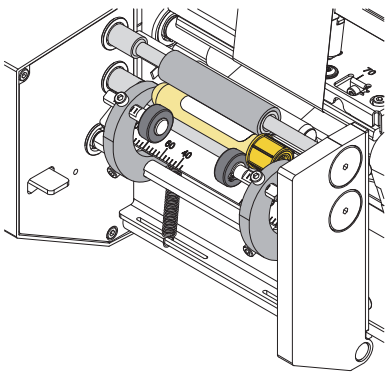

- ▶ Press .

The tube will be pressed against the transport rollers. The first label will be printed and applied onto the turning tube.

After about two turns the locking clamps will be opened. Depending on the configuration the tube will be ejected or left in the labelling area.

- ▶ Remove the tube.
- ▶ Insert the next tube.
- ▶ Press  again to start next cycle.

8 Fault Correction

Error message	Cause	Remedy
<i>Device not locked</i>	The tube applicator is not in operating position	Fold up the applicator.
<i>Initialization failed</i>	Hardware error tube applicator	Switch off and on the system. If error recurs call service.
<i>No tube detected</i>	No tube in the labelling area	Insert tube.
<i>Tube not ejected</i>	Tube was not ejected by the ejection movement.	Remove the tube by hand.
<i>Wrong tube diameter</i>	The tube label applicator has detected a tube with wrong diameter.	Insert a suitable tube.



Brady Worldwide, Inc
6555 West Good Hope Road
Milwaukee, WI 53223
bradyid.com

Brady EMEA
Lindestraat 20
9240 Zele
Belgium
bradycorp.com/global

Brady Corporation Asia
1 Kaki Bukit Crescent
Singapore 416236
bradycorp.com/global

User Manual (Printed-English):
Brady Part No. 151156