

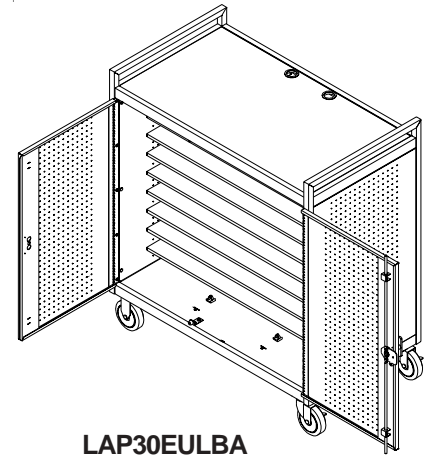

BRETFORD

**LAP30EULBA
LAP30EULFR
NOTEBOOK CART ASSEMBLY
WITH TIMER**

Assembly Instructions for:
**INTERIOR E-UNIT
REPOSITIONING / REPLACEMENT
AND
TIMER REPLACEMENT**



LAP30EULBA

**CAUTION: RISK OF ELECTRICAL SHOCK.
DO NOT PLUG INTO ANOTHER
RELOCATABLE POWER TAP.**

Parts List

Qty.	Part No.	Description
1	LAP30EULBA	Cart Assembly, e-units at back
	LAP30EULFR	Cart Assembly, e-units at front

**NO TV/MONITOR TO BE
USED ON TOP OF CART**

Tools Required

Philips screwdriver

**MAXIMUM WEIGHT OF ACCESSORIES
ON TOP OF CART: 25 LBS.**

The socket-outlet to be installed near the equipment and to be easily accessible.

Do not load each electrical unit with more than 12 A and do not load any receptacle with more than 12 A.

NOTE:

**UNPLUG CART (TIMER) POWER CORD FROM POWER
SOURCE BEFORE STARTING**

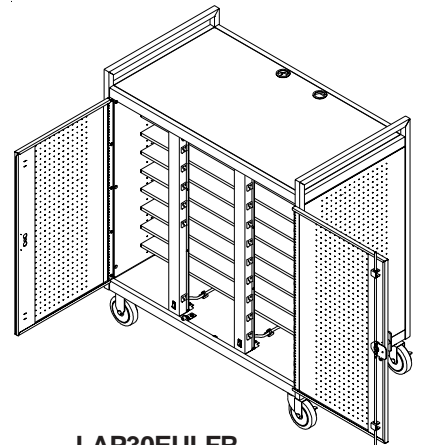

LAP30EULFR

**E-UNIT REPOSITIONING:
'FRONT TO REAR'**

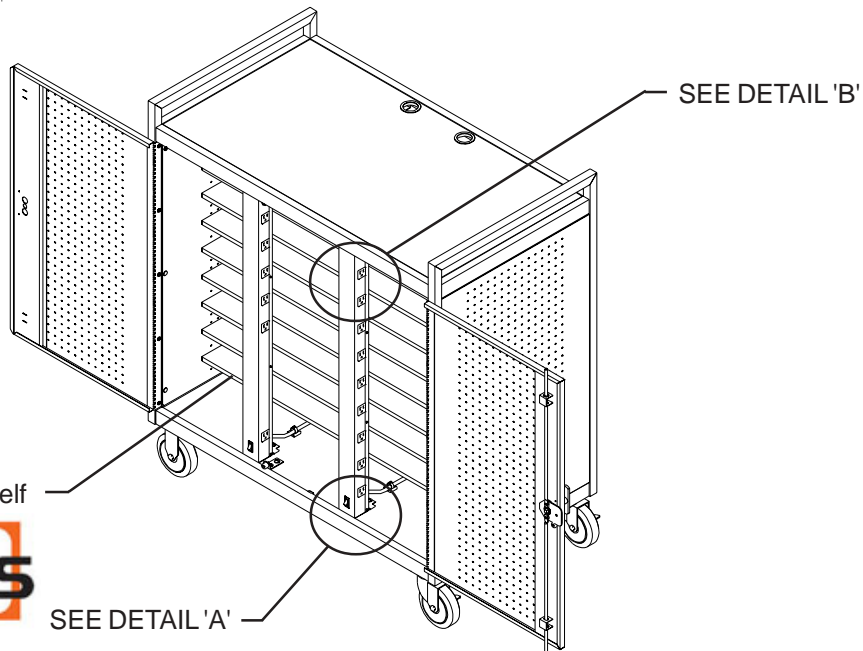

205 Westwood Ave, Long Branch, NJ 07740
Phone: 866-94 BOARDS (26273) / (732)-222-1511
Fax: (732)-222-7088 | E-mail: sales@touchboards.com

Step 1

Open both front doors of cart to access E-Units. From underneath the bottom shelf, carefully unplug the power cords of the E-Units from the timer assembly (see Front View) and unclip the power cords from the 4 clips located at the bottom panel of the cart. Loosen the screw holding the E-Unit bracket assembly and remove all 4 bracket assemblies (see DETAILS 'A' and 'B').

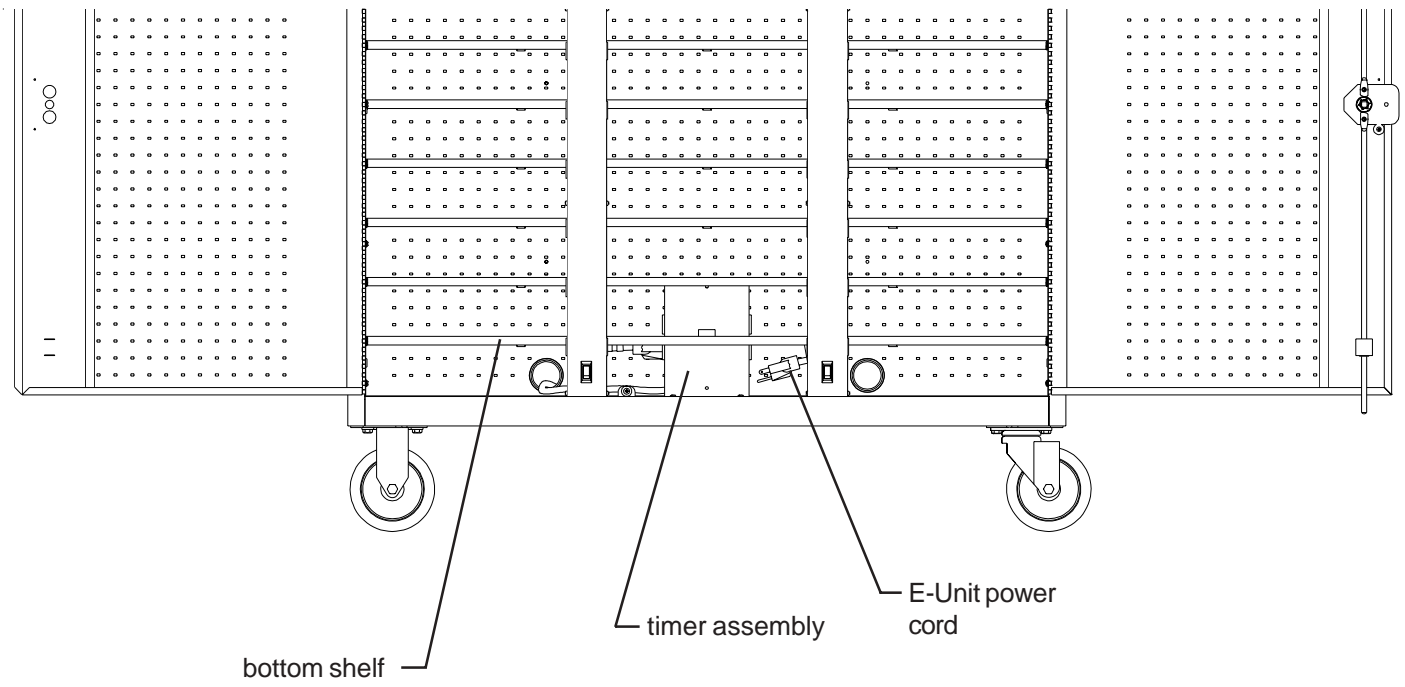

Front View

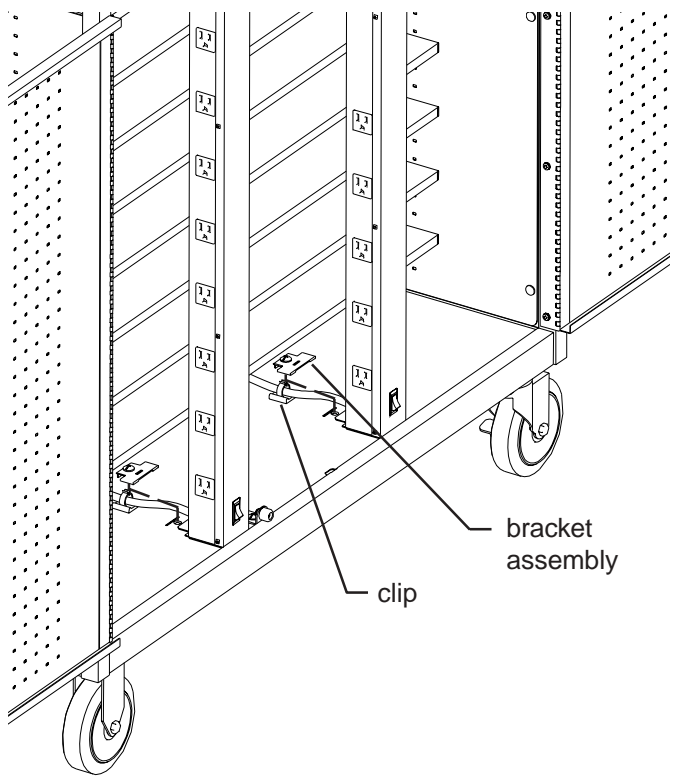

DETAIL 'A'

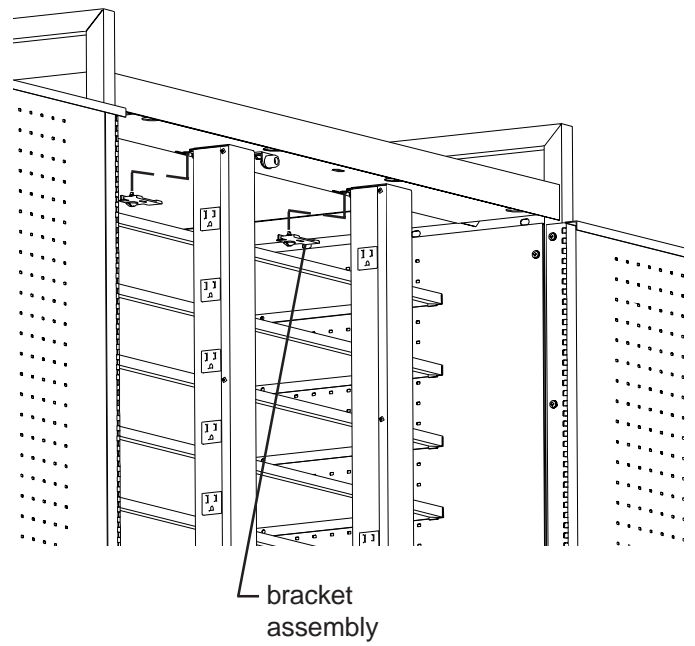

DETAIL 'B'

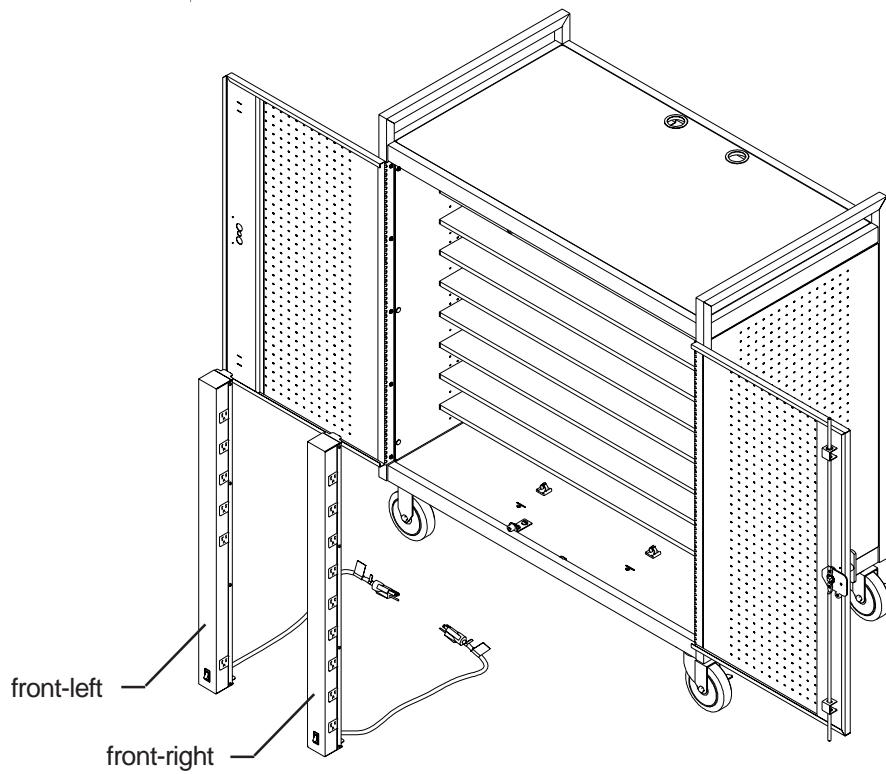

Step 2

Remove **front-left** E-Unit by gripping the top and tilt it side ways until it clears the underside of the cart interior shelf channel and set it aside.
 Remove **front-right** E-Unit by gripping the top and tilt it side ways until it clears the underside of the cart interior shelf channel and set it aside.

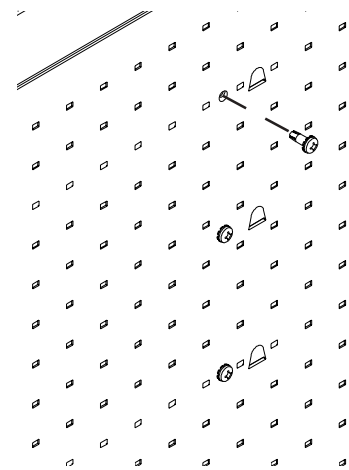
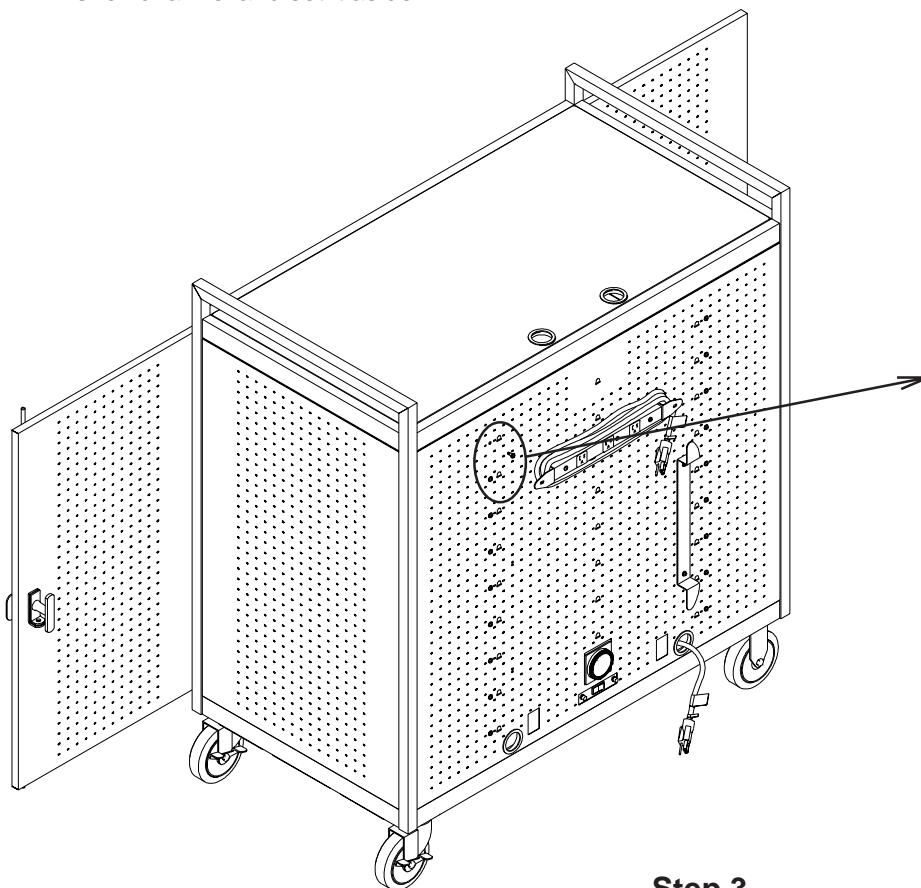

DETAIL 'C'

Step 3

Remove 18 screws (2 per shelf) from rear panel that secure the 9 interior shelves (see DETAIL 'C').

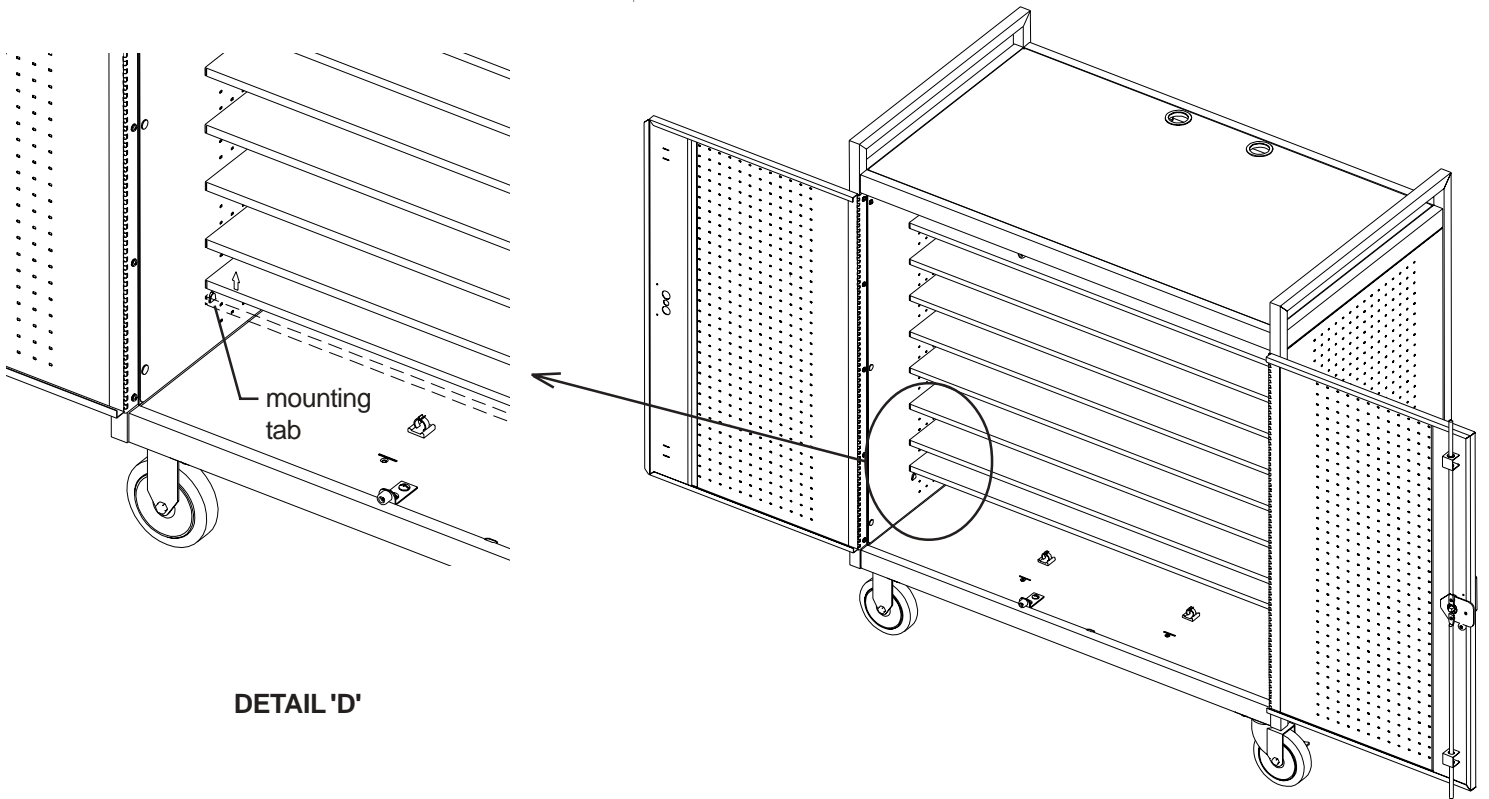

DETAIL 'D'

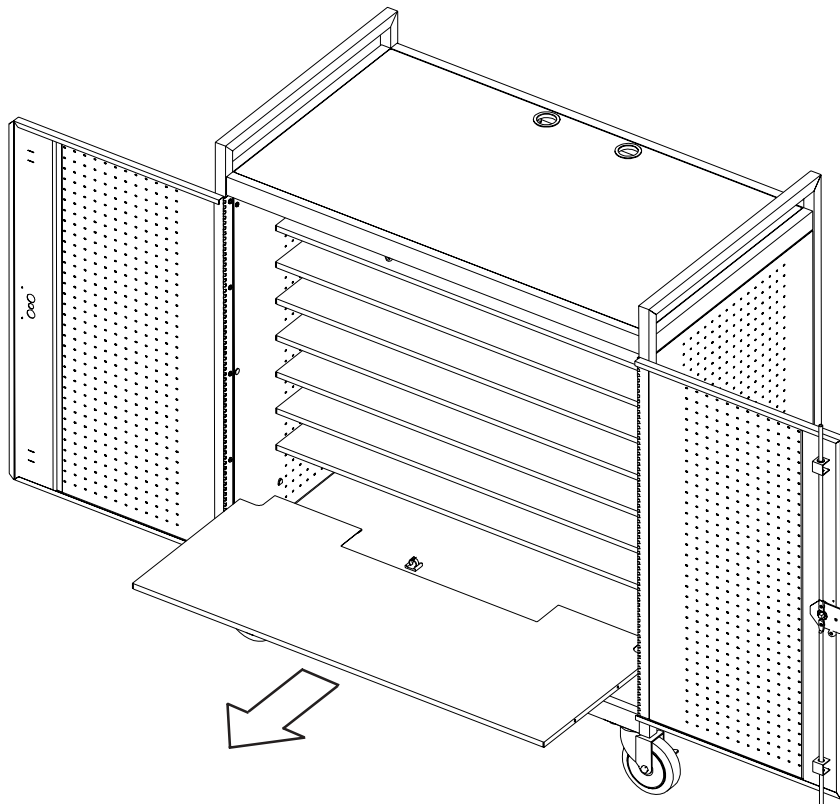

Step 4

Remove each interior shelf by carefully pushing upward (to release shelf from mounting tabs) shown in Detail 'D', then carefully sliding out. Set each shelf aside.

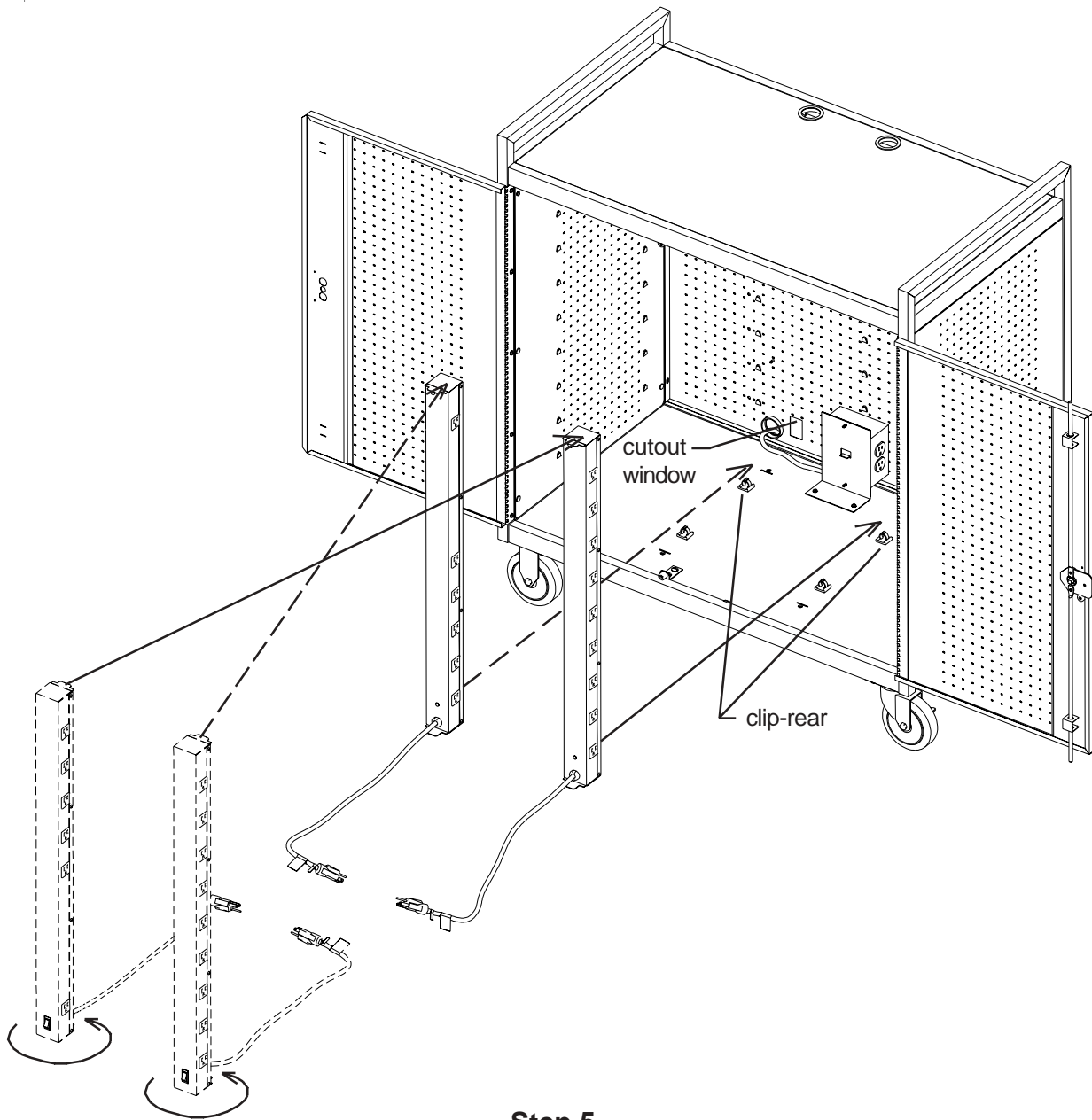

Step 5

Reinstall the E-Units (set aside from being removed from the front) as follows:

1. Rotate the E-Unit 180 degrees (from original position).
2. Cross over to the rear of cart.
3. Tilt in and set bottom in back, in front of rear panel cutout window.
4. Grip the top and tilt to the upright position, underneath top panel bracket.

When repositioned correctly, the E-Unit power switch should be visible from rear panel cutout window. Reinstall the E-Unit bracket assemblies (make sure that the top flange of the E-unit is aligned with the slot in the bracket assembly) and tighten screws securely. Plug in the E-Units power cords into the bottom outlets of the timer assembly. Press each E-Unit power cord into the single wire clip located at the rear/bottom of the cart only. Fold the power cords into a 'c' pattern loop on the bottom surface (see view in Step 6).

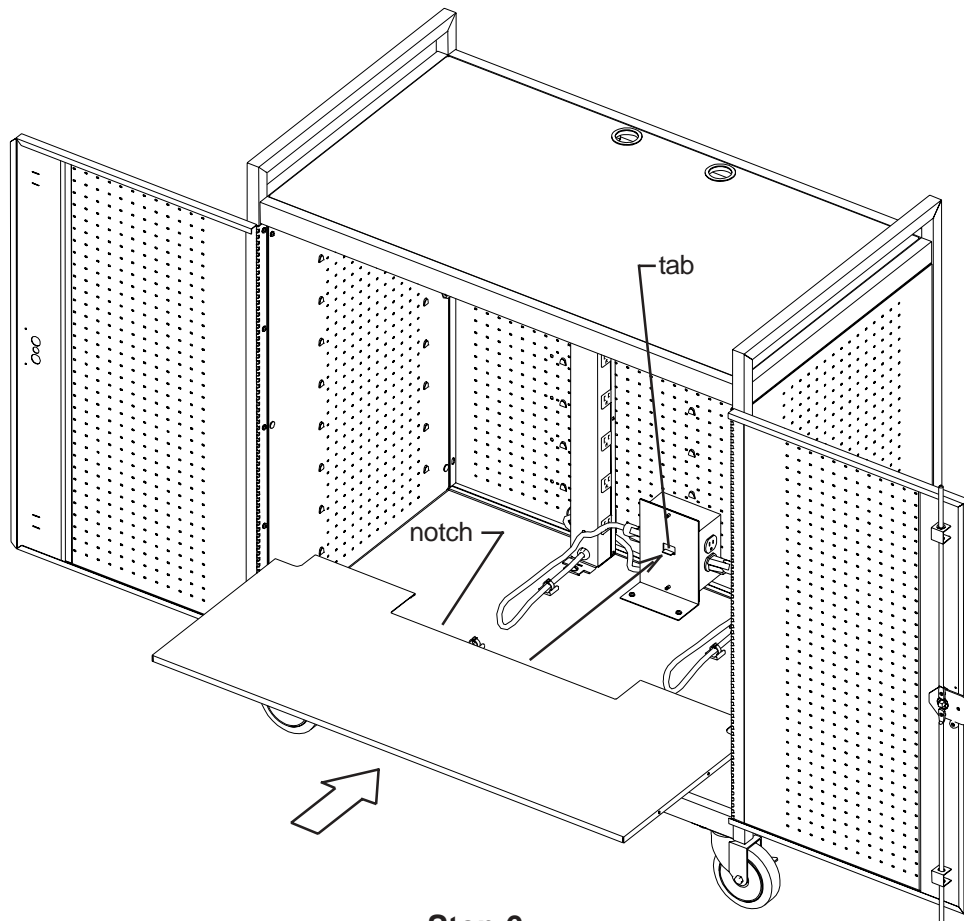

Step 6

Reinstall the 9 interior shelves as follows:

1. Carefully slide in the shelf with notch, at the **bottom** position (the notch will rest on the bracket tab).
(Make sure that the shelf flanges are ALL seated into the mounting tabs.)
2. Slide in all remaining shelves into position as the bottom shelf.

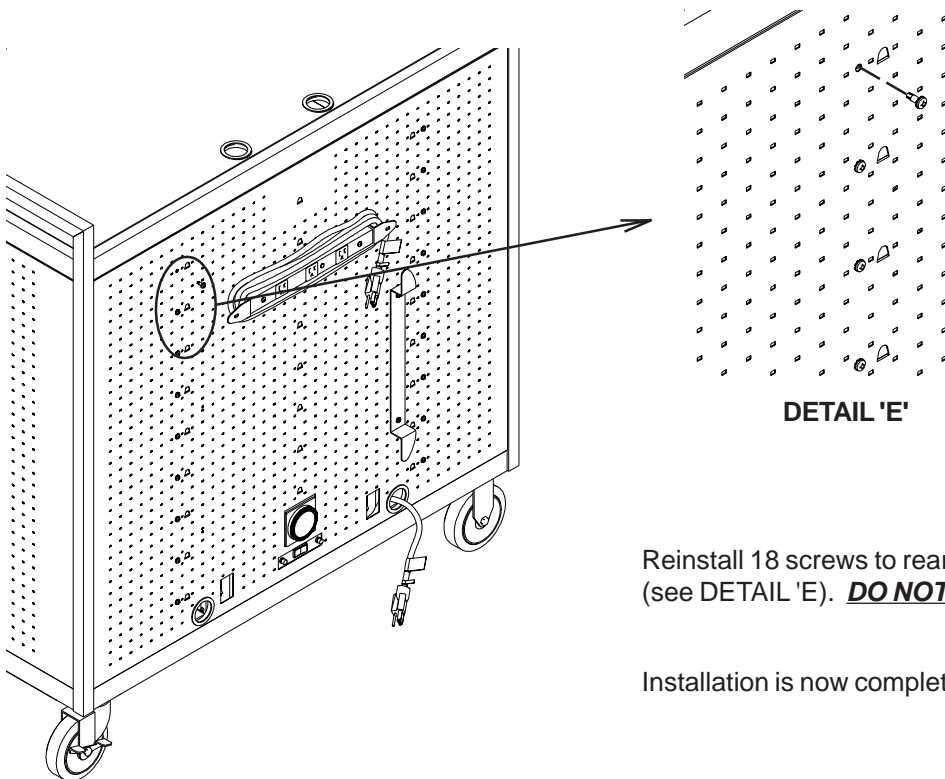

DETAIL 'E'

Step 7

Reinstall 18 screws to rear panel that will secure the 9 interior shelves (see DETAIL 'E'). **DO NOT OVER TIGHTEN SCREWS.**

Installation is now complete and ready for use.

NOTE:

**UNPLUG CART (TIMER) POWER CORD FROM
POWER SOURCE BEFORE STARTING**

**E-UNIT REPOSITIONING:
'REAR TO FRONT'**

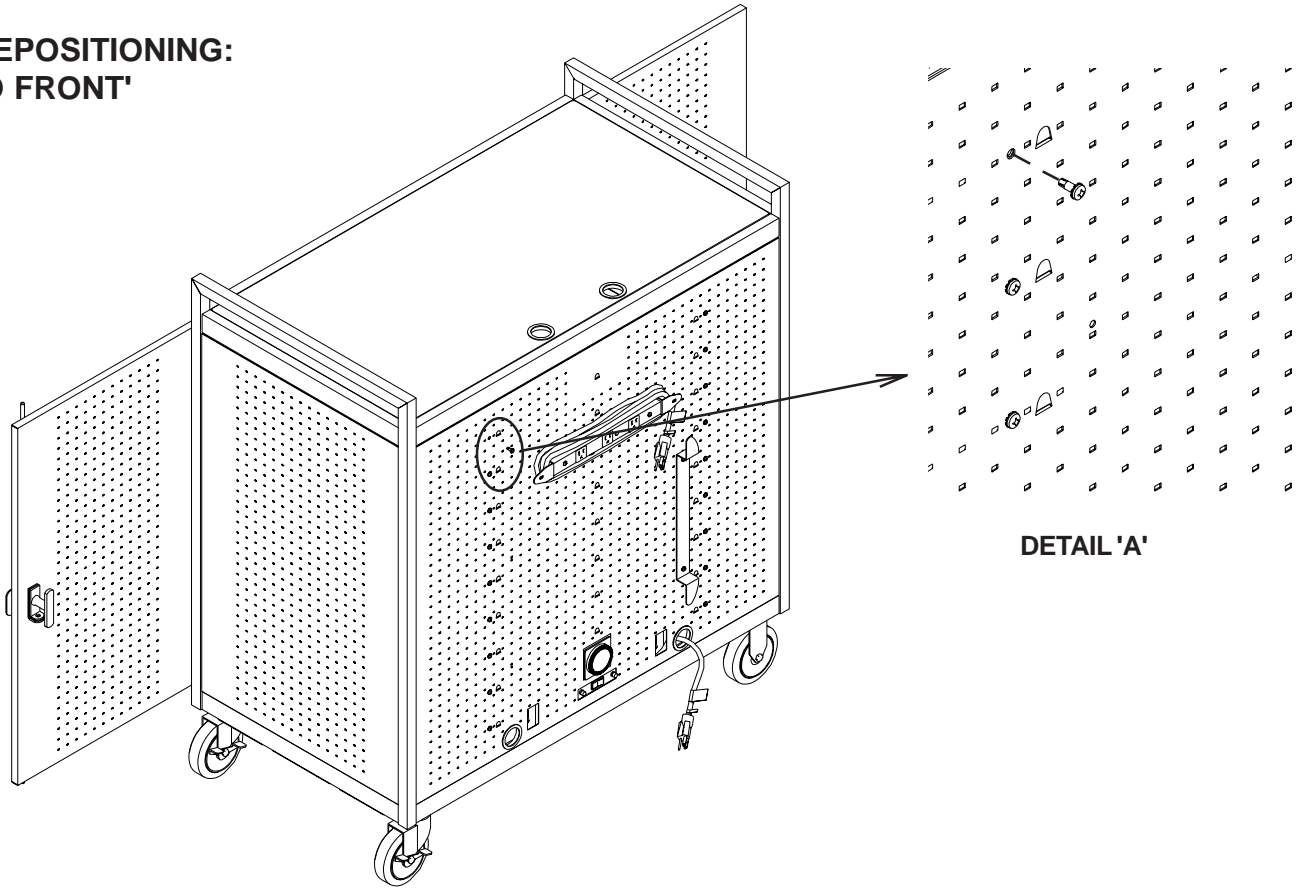

Step 1

Remove 18 screws (2 per shelf) from rear panel that secure the 9 interior shelves (see DETAIL 'A').

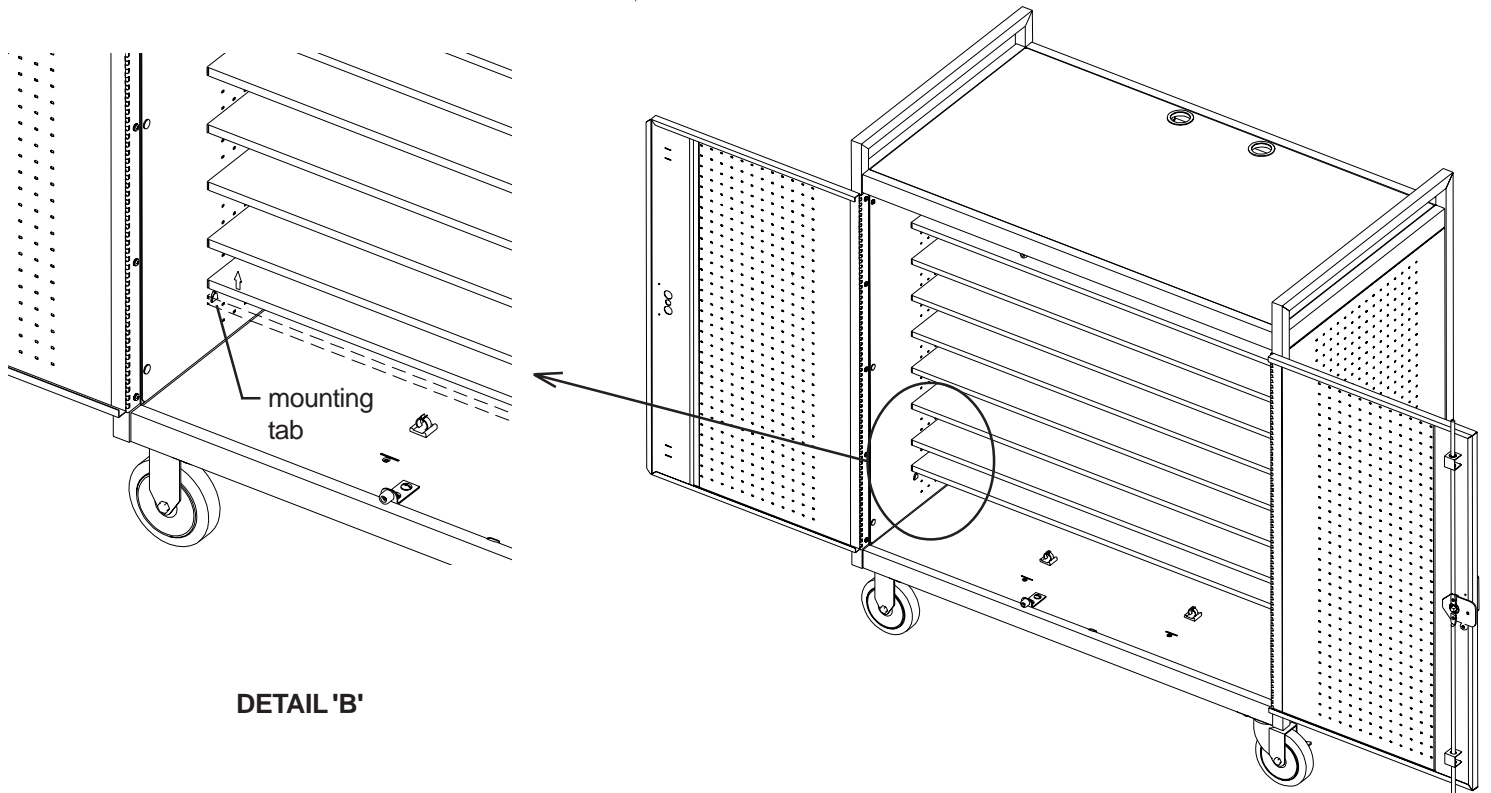

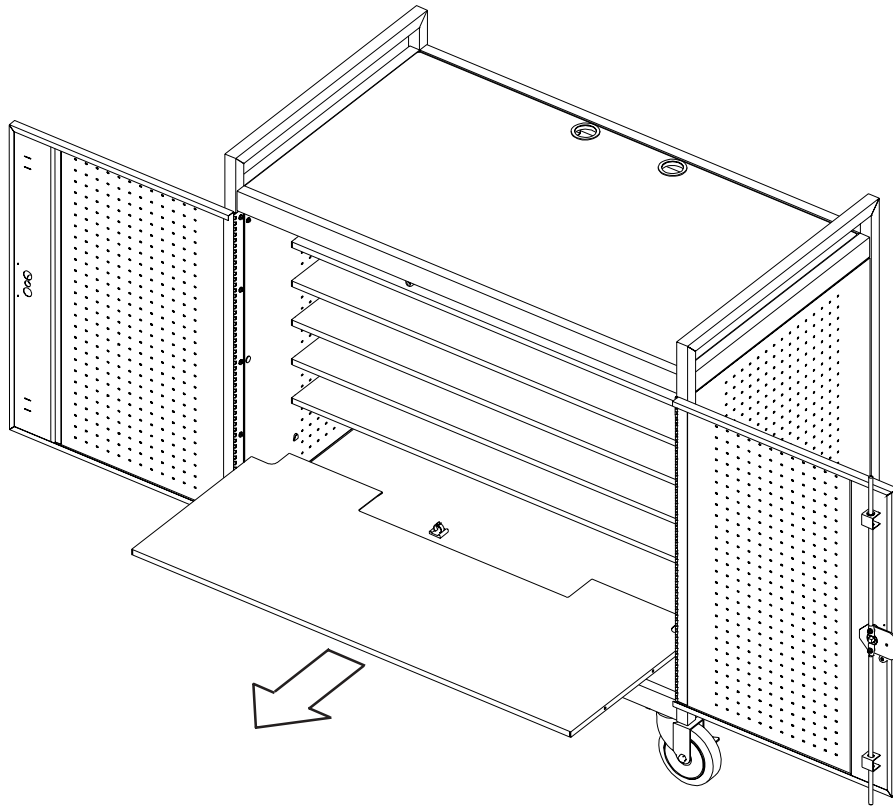

Step 2

With both doors open, remove each interior shelf by carefully pushing upward (to release shelf from mounting tabs) shown in Detail 'B', then carefully sliding out. Set each shelf aside.

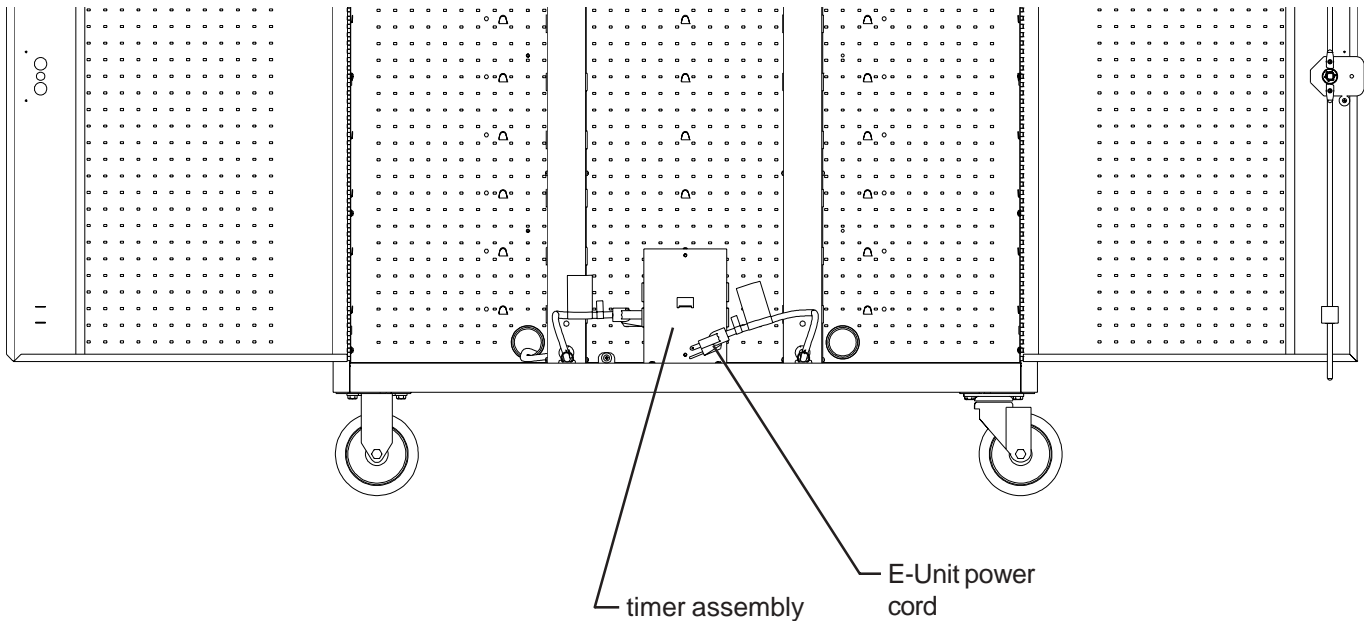

Front View

Carefully unplug the power cords of the E-Units from the timer assembly (see Front View) and unclip the power cords from the clips at the rear of cart. Loosen the screw holding the E-Unit bracket assembly and remove all 4 bracket assemblies (see DETAILS 'C' and 'D').

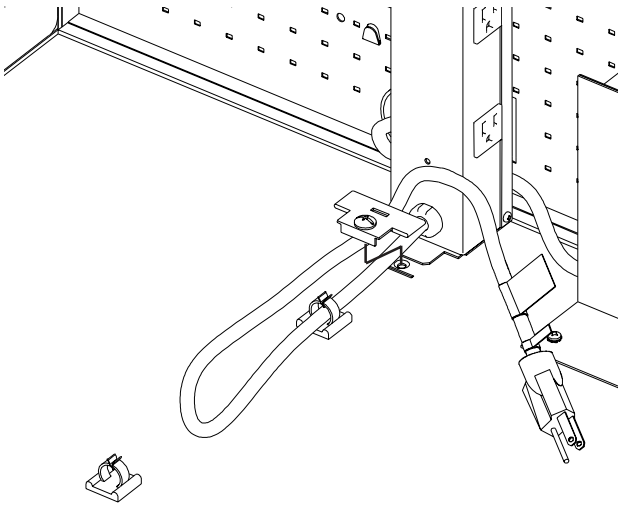

DETAIL 'C'

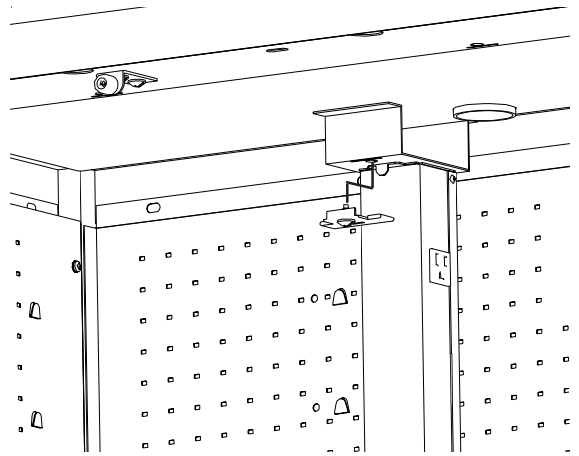

DETAIL 'D'

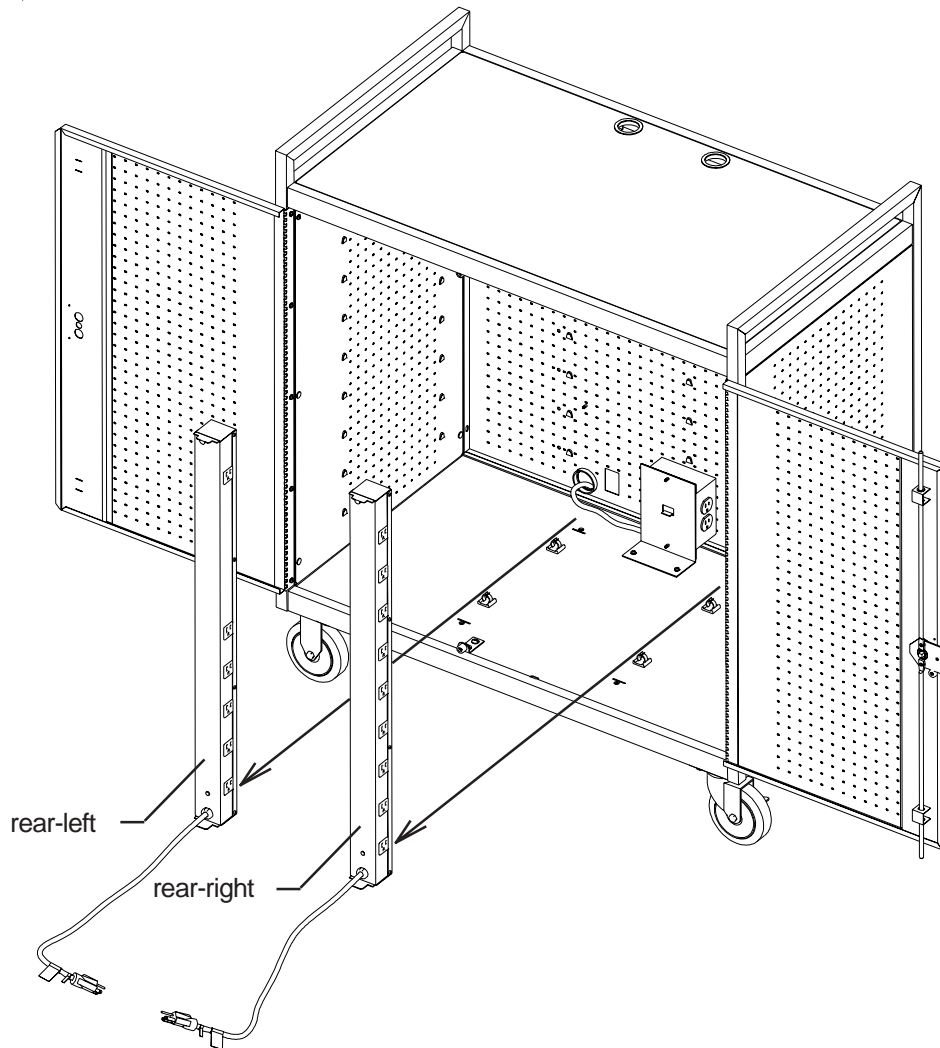

Step 3

Remove **rear-left** E-Unit by gripping the top and tilt it side ways until it clears the underside of the cart interior shelf bracket and set it aside.

Remove **rear-right** E-Unit by gripping the top and tilt it side ways until it clears the underside of the cart interior shelf bracket and set it aside.

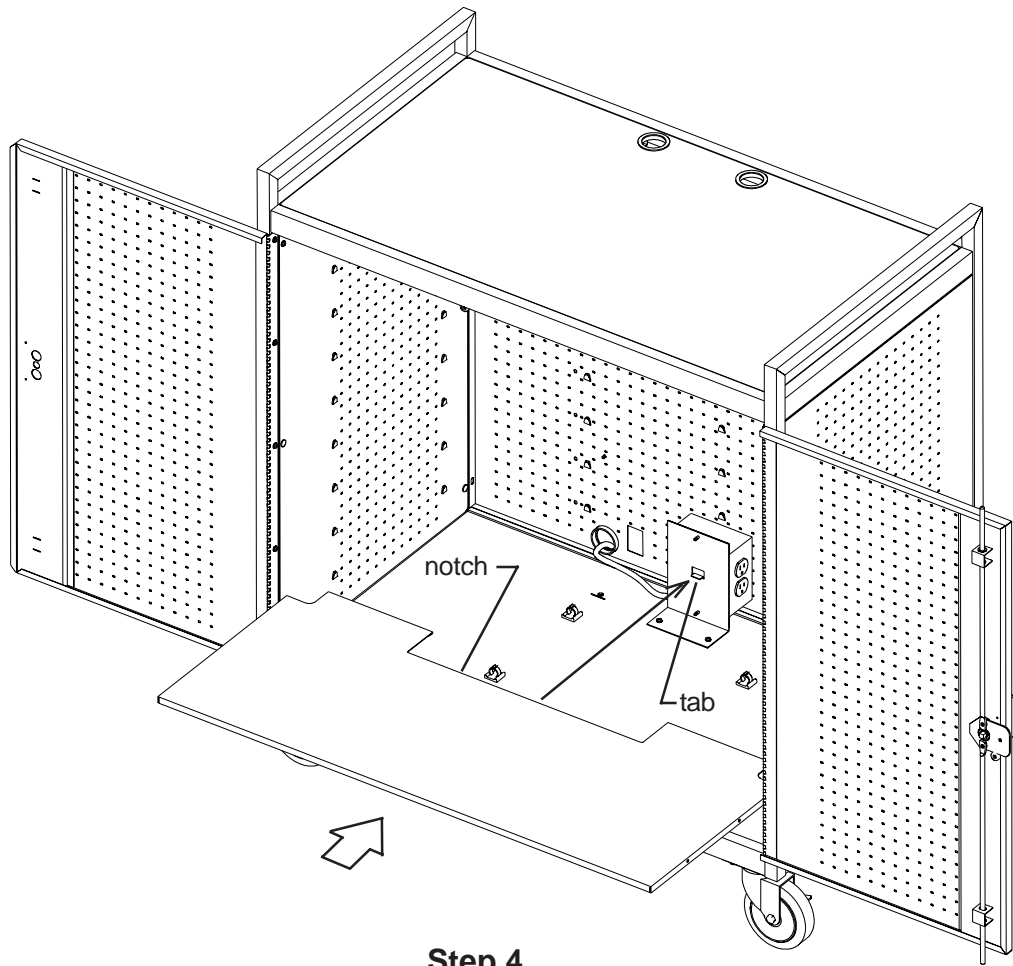

Step 4

Reinstall the 9 interior shelves as follows:

1. Carefully slide in the shelf with notch at the **bottom** position (the notch will rest on the bracket tab).
(Make sure that the shelf flanges are ALL seated into the mounting tabs.)
2. Slide in all remaining shelves into position as the bottom shelf.

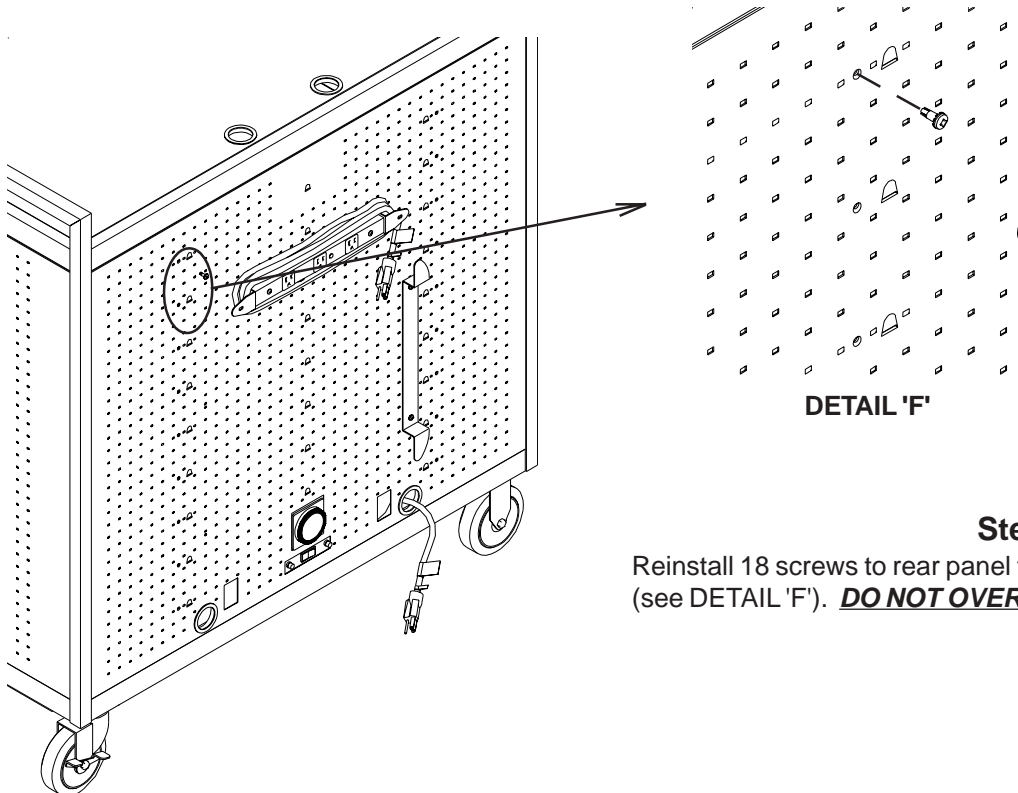

DETAIL 'F'

Step 5

Reinstall 18 screws to rear panel that will secure the 9 interior shelves (see DETAIL 'F'). **DO NOT OVER TIGHTEN SCREWS.**

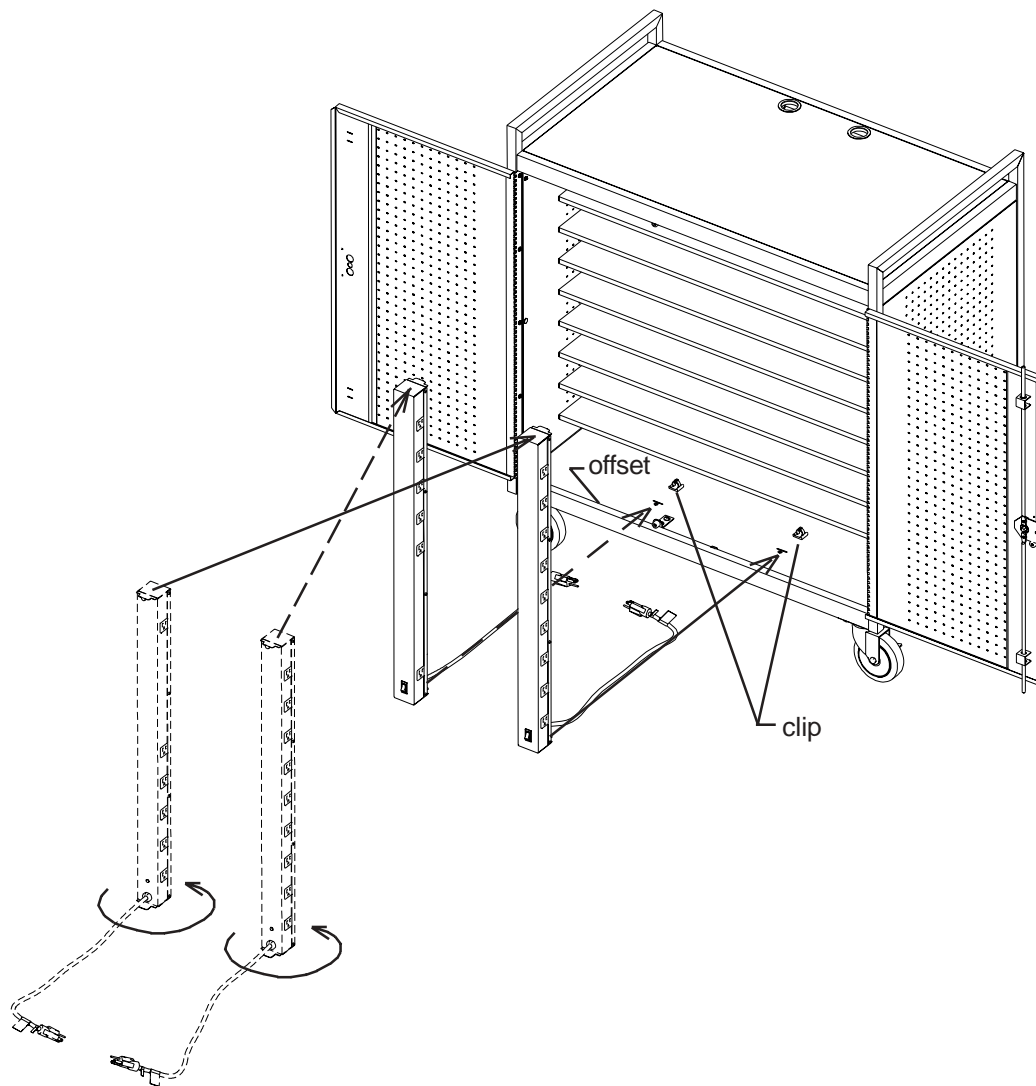

Step 6

Reinstall the E-Units (set aside from being removed from the rear) as follows:

1. Rotate the E-Unit 180 degrees (from original position).
2. Cross over to the front of cart.
3. Tilt in and set against offset of bottom panel (of cart).
4. Grip the top and tilt to the upright position.

When repositioned correctly, the E-Unit power switch should face the front.

Reinstall the E-Unit bracket assemblies (make sure that the top flange of the E-unit is aligned with the slot in the bracket assembly) and tighten screws securely.

Plug in the E-Units power cords into the bottom outlets of the timer assembly.

Press each E-Unit power cord into the two wire clips located (in line, behind E-Unit) on the bottom of cart.

Installation is now complete and ready for use.

NOTE:

**UNPLUG CART (TIMER) POWER CORD FROM
POWER SOURCE BEFORE STARTING**

**E-UNIT REPLACEMENT:
'REAR LOCATION'**

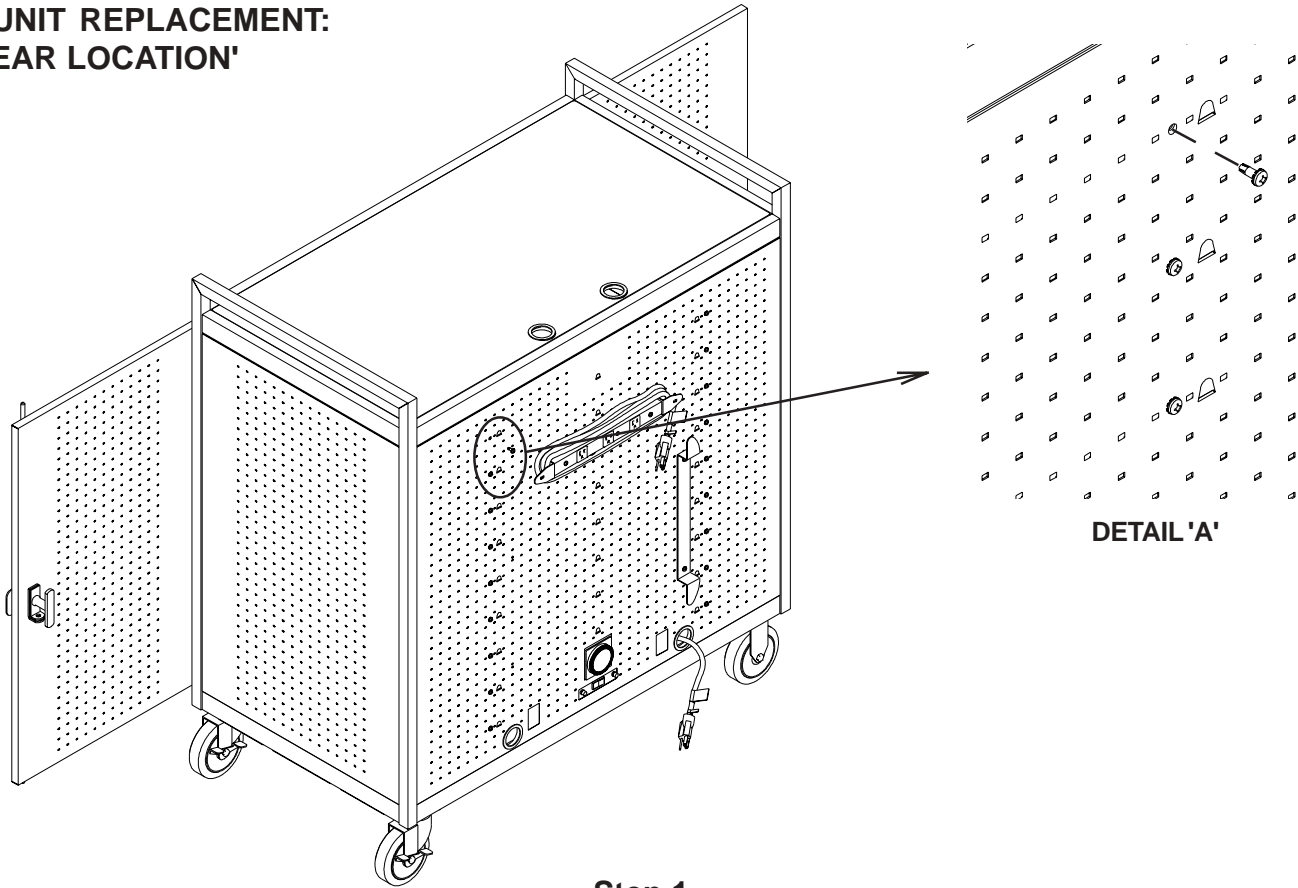

Step 1

Remove 18 screws (2 per shelf) from rear panel that secure the 9 interior shelves (see DETAIL 'A').

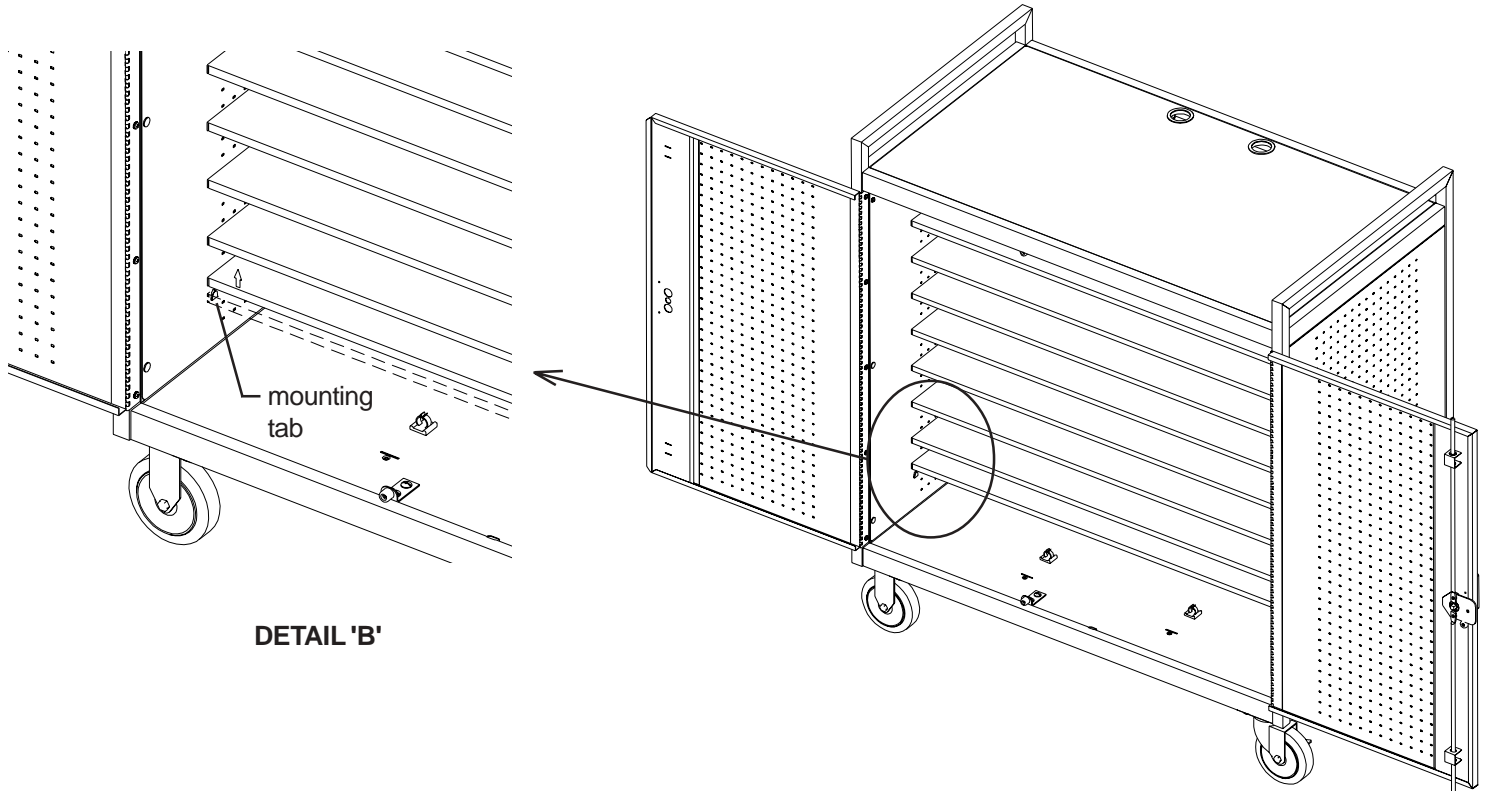

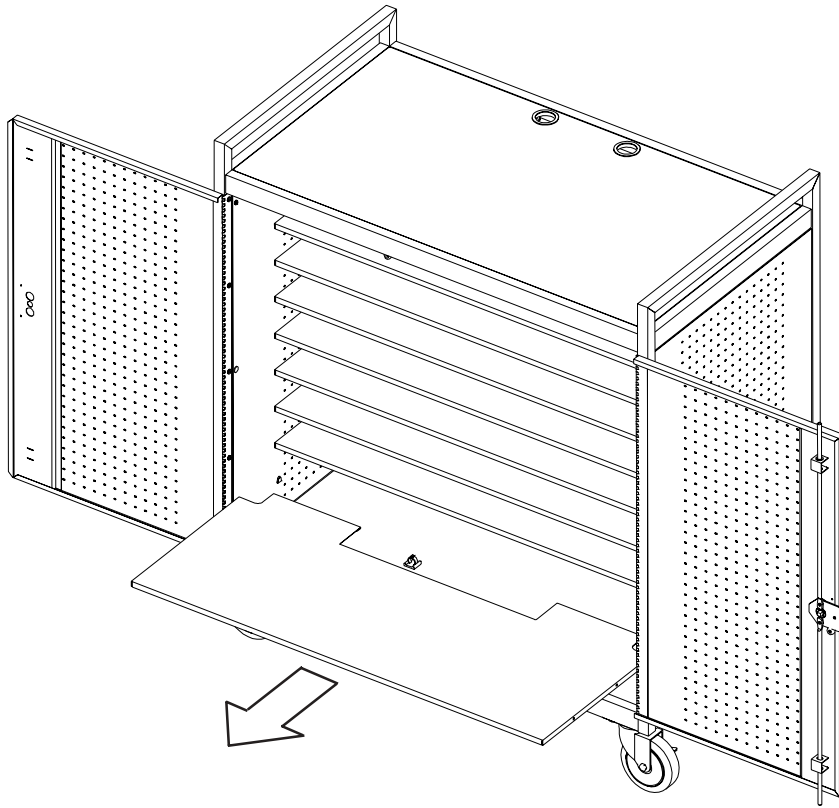

Step 2

With both doors open, remove each interior shelf by carefully pushing upward (to release shelf from mounting tabs) shown in Detail 'B', then carefully sliding out. Set each shelf aside.

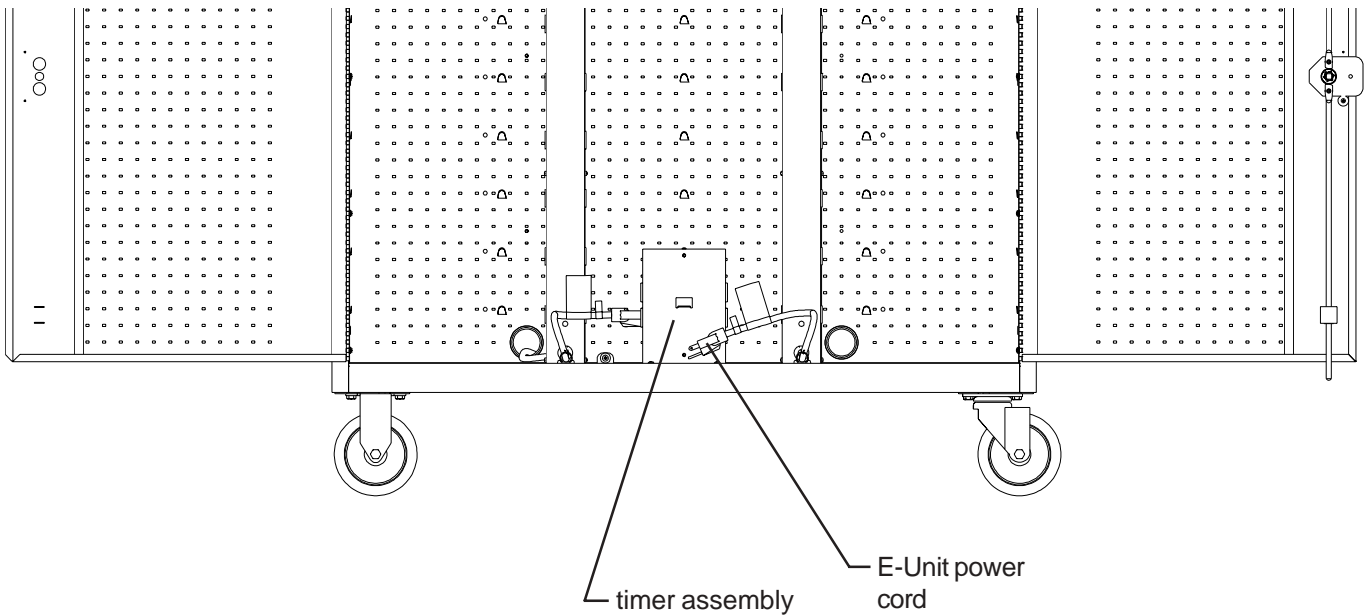

Front View

Carefully unplug the power cord(s) of the E-Unit(s) from the timer assembly (see Front View) and unclip the power cord(s) from the clip(s) at the rear of cart. Loosen the screw holding the E-Unit bracket assembly and remove each bracket assembly (see DETAILS 'C' and 'D').

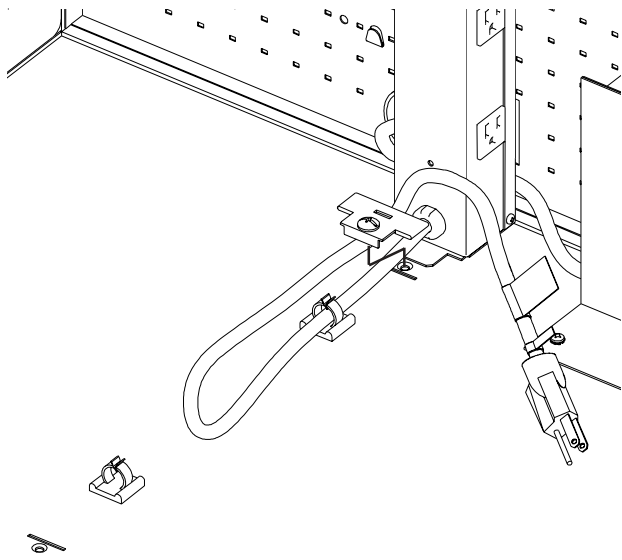

DETAIL 'C'

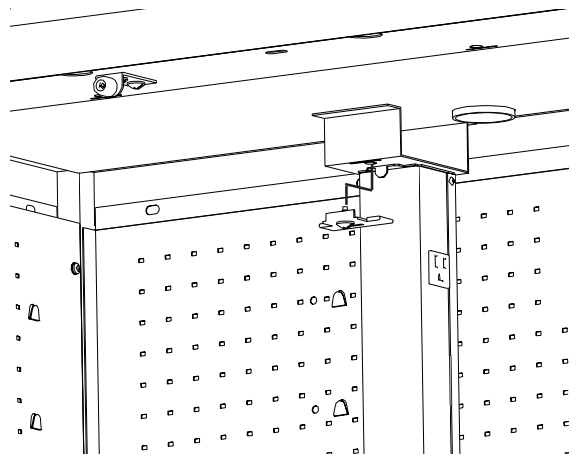

DETAIL 'D'

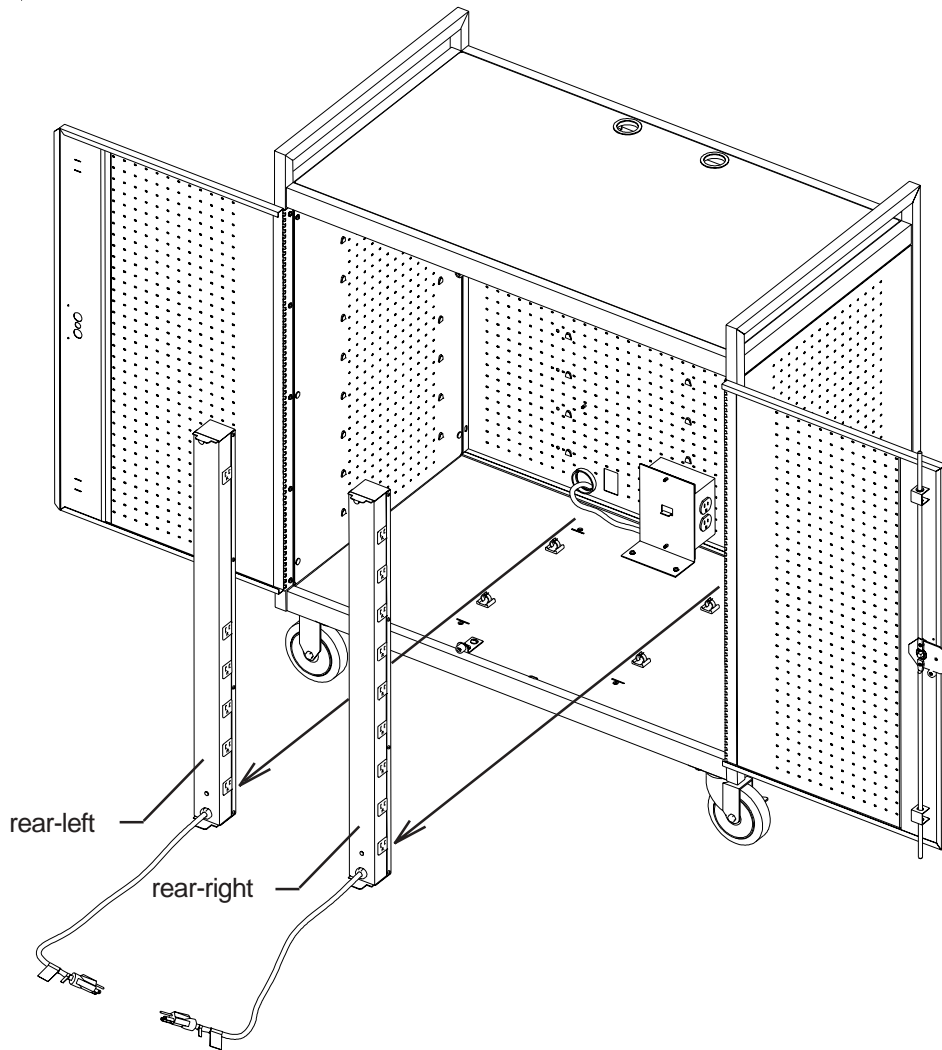

Step 3

Remove E-Unit(s) by gripping the top and tilt it side ways until it clears the underside of the cart interior shelf bracket and set it aside.

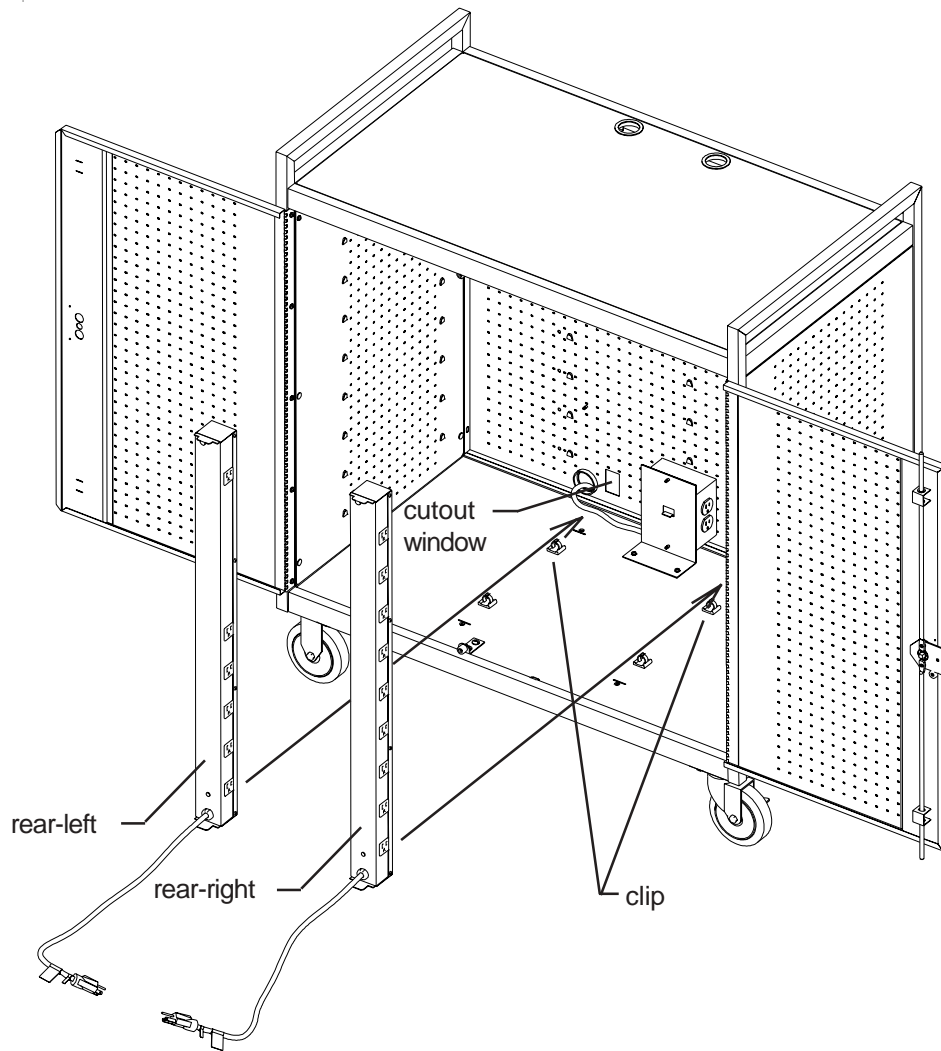

Step 4

Carefully install replacement E-Unit(s) into position by placing bottom in first and tilting in sideways to the top. When repositioned correctly, the E-Unit(s) power switch should be visible from rear panel cutout window. Reinstall the E-Unit bracket assemblies (make sure that the top flange of the E-unit is aligned with the slot in the bracket assembly) and tighten screws securely. Plug in the E-Unit(s) power cord(s) into the bottom outlet(s) of the timer assembly. Press E-Unit power cord(s) into the wire clip(s) located at the rear/bottom of the cart. Fold the power cords into a 'c' pattern, on the bottom surface (see view in Step 5).

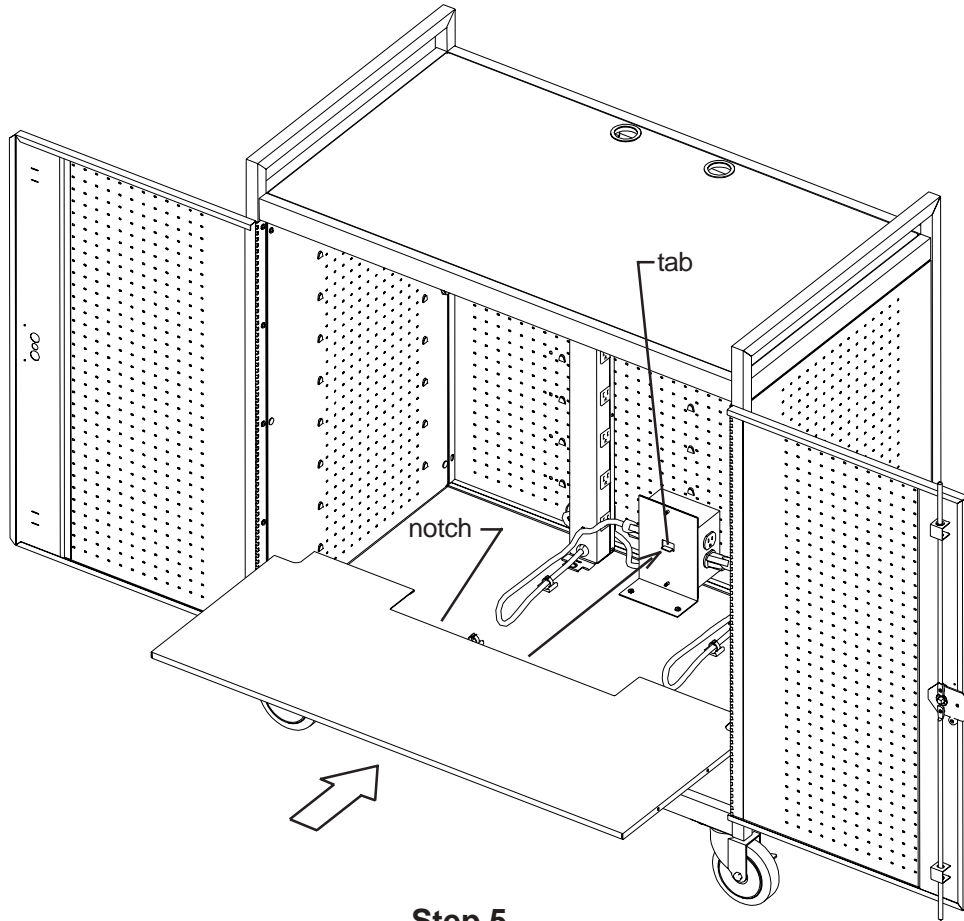

Step 5

Reinstall the 9 interior shelves as follows:

1. Carefully slide in the shelf with notch, at the **bottom** position (the notch will rest on the bracket tab).
(Make sure that the shelf flanges are ALL seated into the mounting tabs.)
2. Slide in all remaining shelves into position as the bottom shelf.

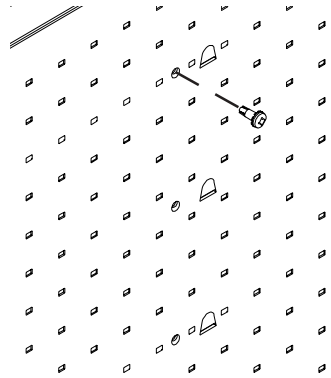
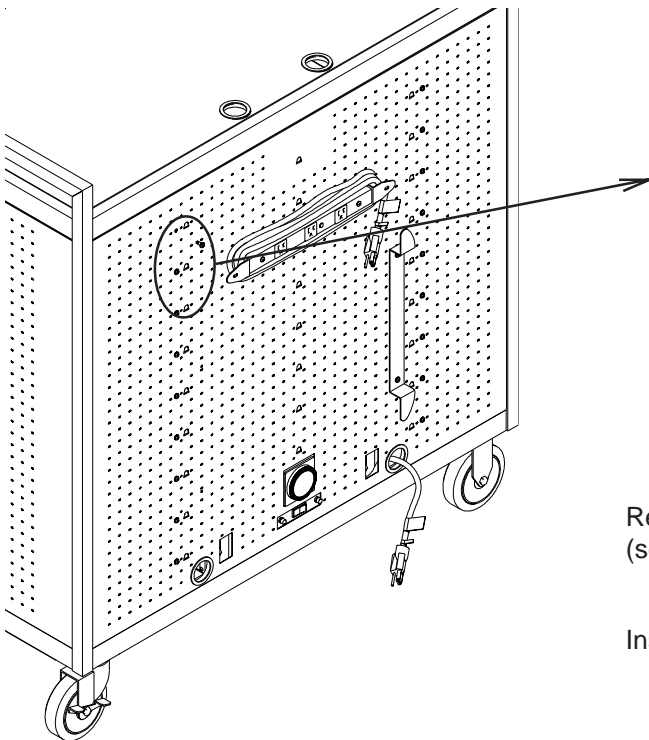

DETAIL 'E'

Step 6

Reinstall 18 screws to rear panel that will secure the 9 interior shelves (see DETAIL 'E'). **DO NOT OVER TIGHTEN SCREWS.**

Installation is now complete and ready for use.

NOTE:

**UNPLUG CART (TIMER) POWER CORD FROM
POWER SOURCE BEFORE STARTING**

**E-UNIT REPLACEMENT:
'FRONT LOCATION'**

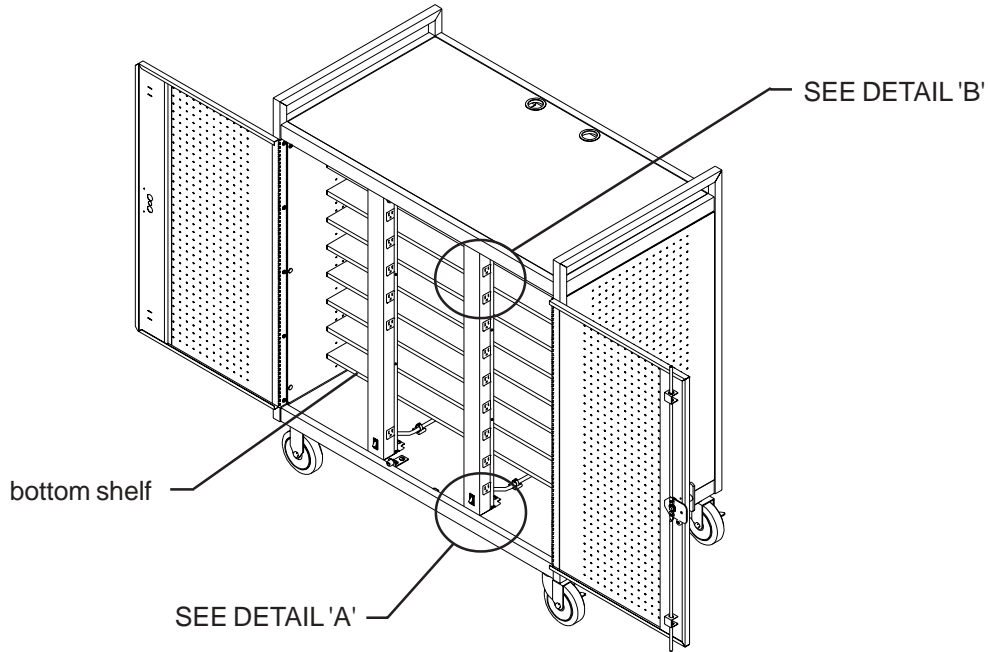

Step 1

Open both front doors of cart to access E-Unit(s). From underneath the bottom shelf, carefully unplug the power cord of the E-Unit(s) from the timer assembly (see Front View) and unclip the power cord(s) from the bottom of cart. Loosen the screw holding the E-Unit bracket assembly and remove (2) bracket assemblies of the E-Unit(s) to be replaced (see DETAILS 'A' and 'B').

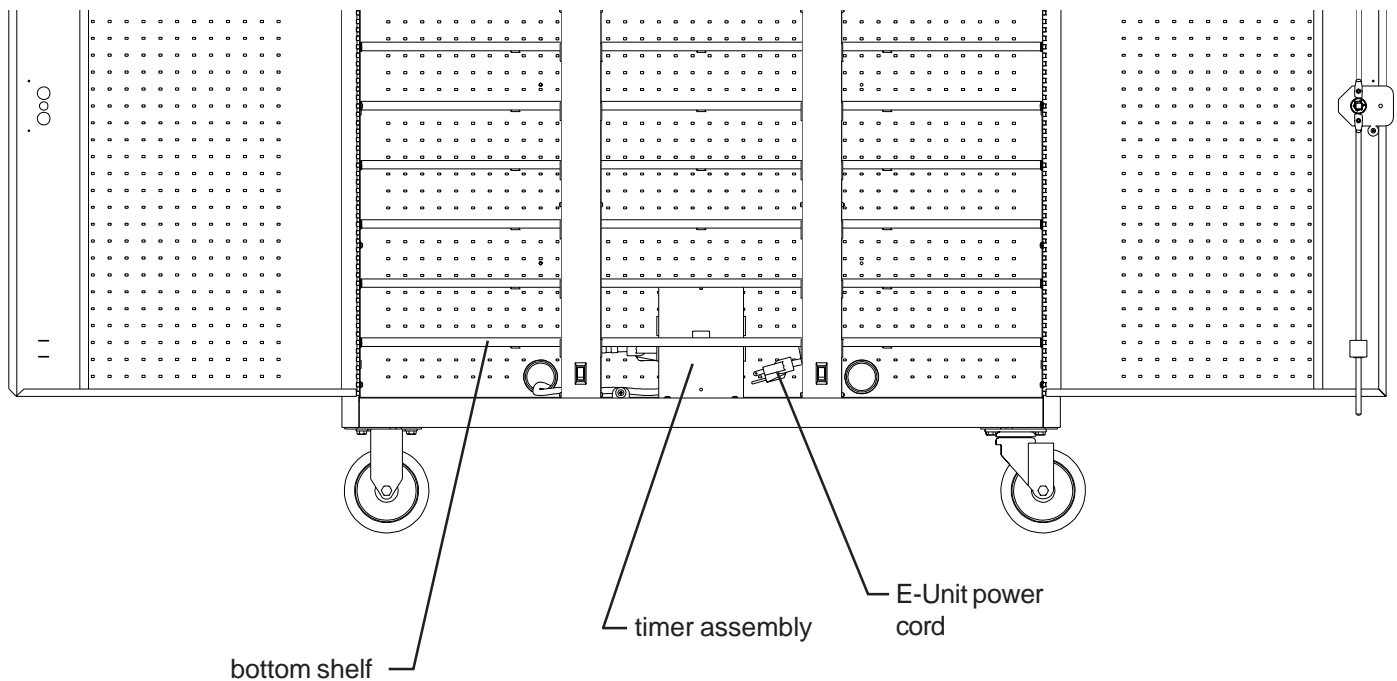

Front View

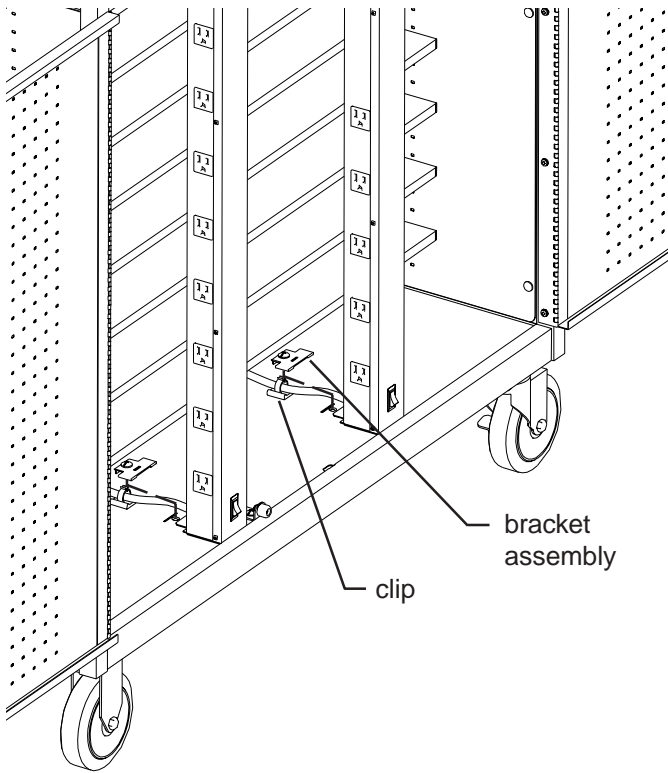

clip
bracket assembly

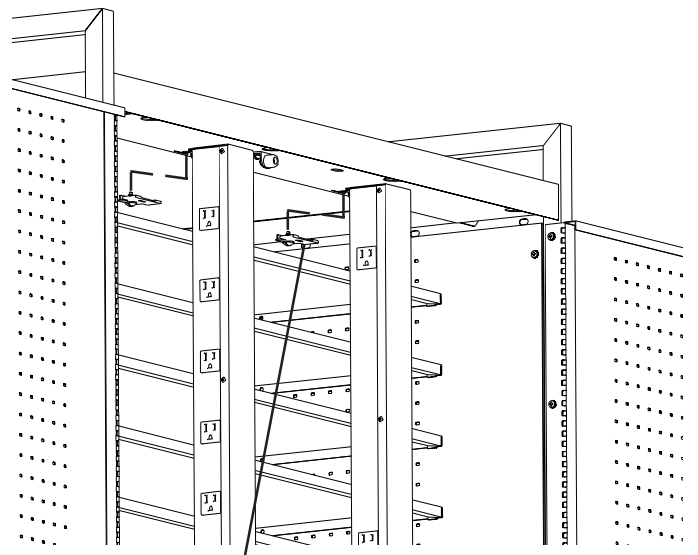

bracket assembly

DETAIL 'B'

DETAIL 'A'

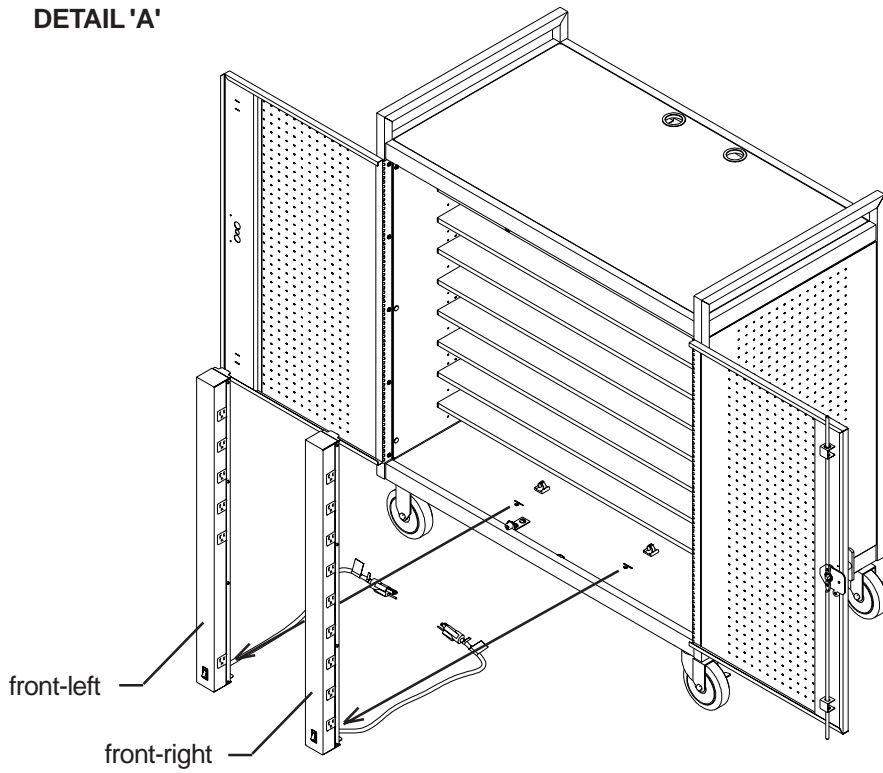

front-left

front-right

Step 2

Remove E-Unit(s) by gripping the top and tilt it side ways until it clears the underside of the cart interior shelf channel and set it aside.

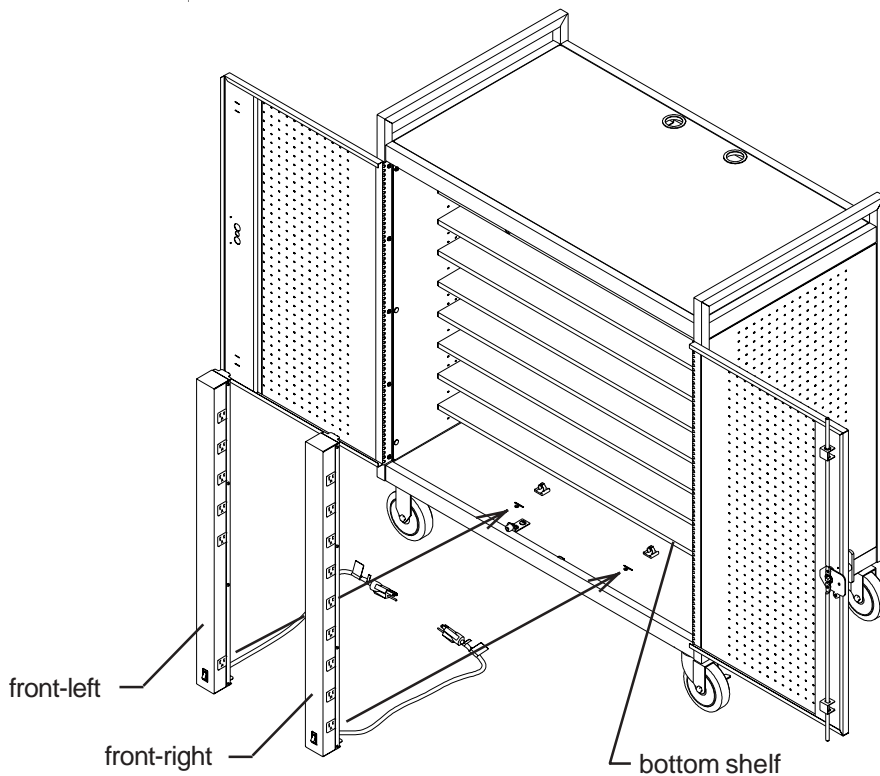

Step 3

Carefully install replacement E-Unit(s) into position by placing bottom in first and tilting it in sideways to the top. When repositioned correctly, the E-Unit(s) power switch should face the front. Reinstall the E-Unit bracket assemblies (make sure that the top flange of the E-unit is aligned with the slot in the bracket assembly) and tighten screws securely. Plug in the E-Unit power cord(s) into the bottom outlet(s) of the timer assembly (located underneath bottom shelf). Press E-Unit power cord(s) into the two wire clips located [in line, behind E-Unit(s)] on the bottom of cart.

Installation is now complete and ready for use.

Touchboards

205 Westwood Ave, Long Branch, NJ 07740

Phone: 866-94 BOARDS (26273) / (732)-222-1511

Fax: (732)-222-7088 | E-mail: sales@touchboards.com

NOTE:
UNPLUG CART (TIMER) POWER CORD FROM
POWER SOURCE BEFORE STARTING

TIMER REPLACEMENT:
'E-UNIT AT REAR LOCATION'

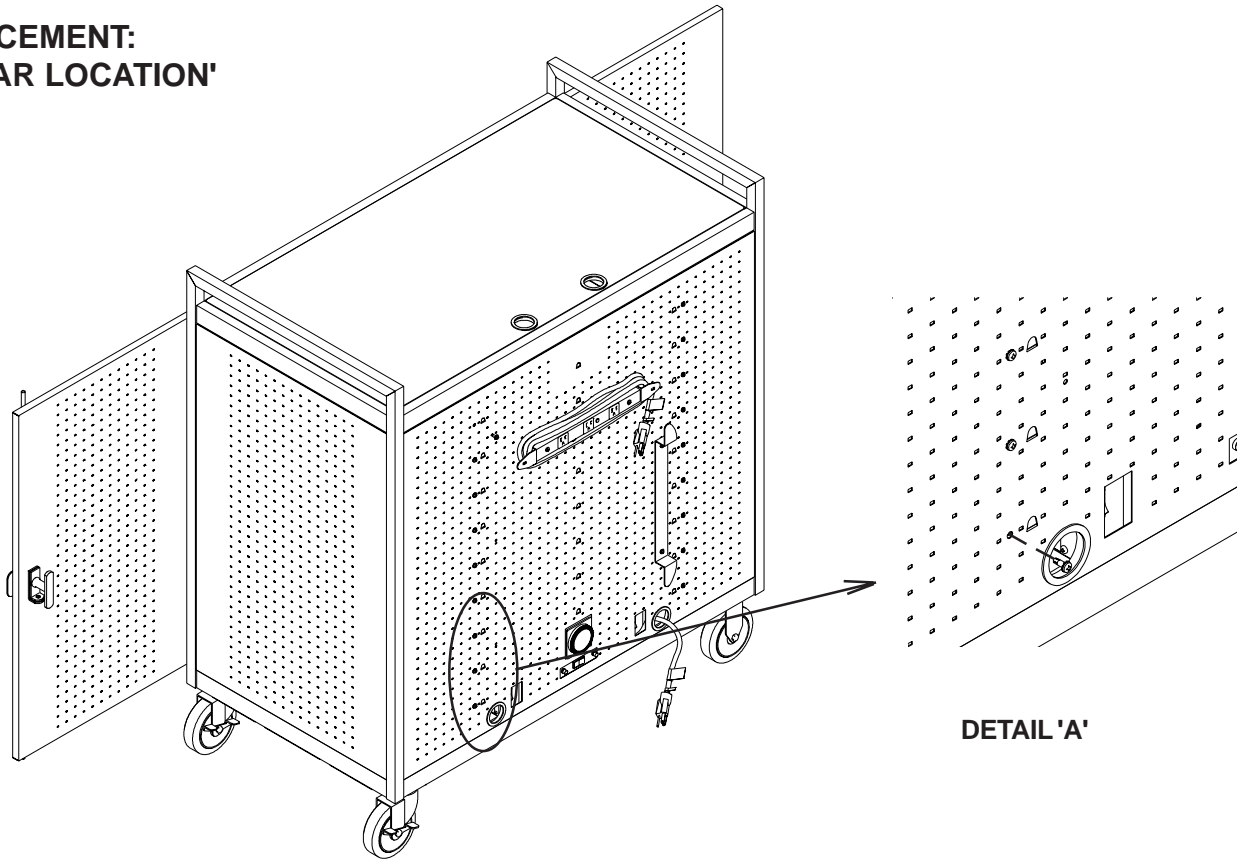

DETAIL 'A'

Step 1

Remove 6 screws (2 per shelf) from rear panel that secure the 3 **bottom** interior shelves (see DETAIL 'A').

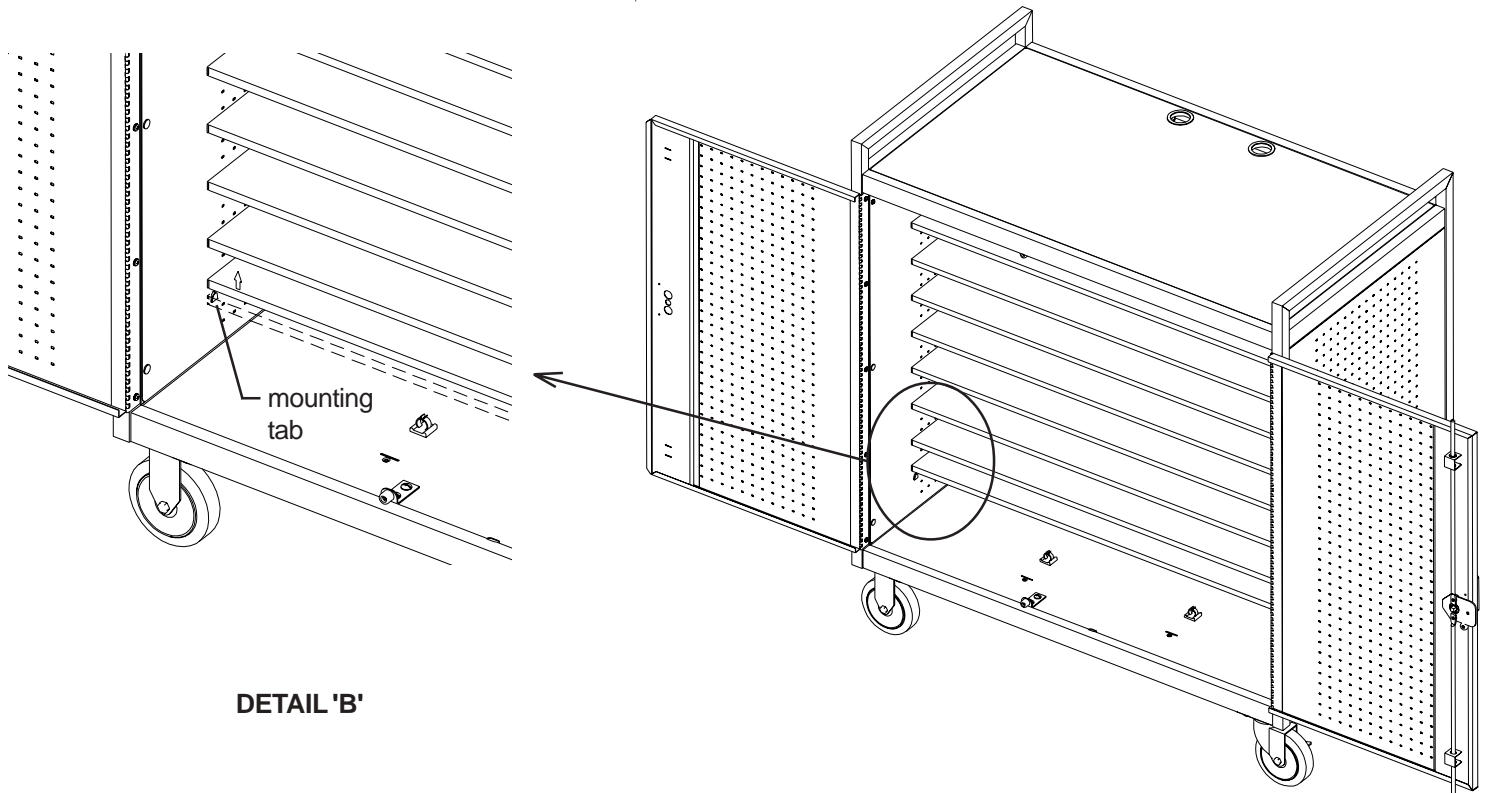

DETAIL 'B'

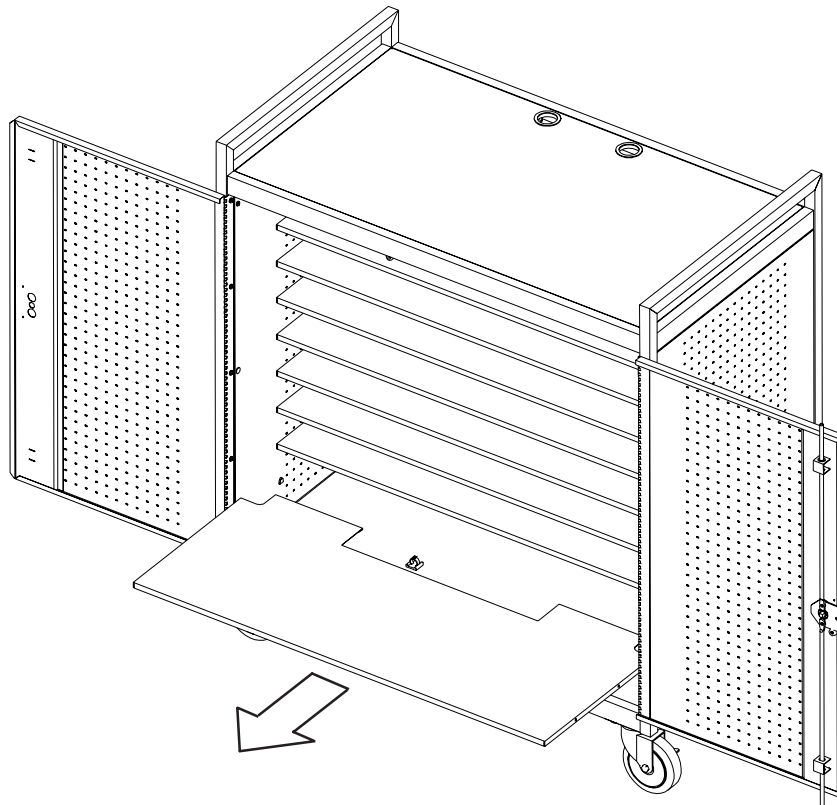

Step 2

With both doors open, remove the 3 bottom interior shelves by carefully pushing upward (to release shelf from mounting tabs) shown in Detail 'B', then carefully sliding out. Set each shelf aside.

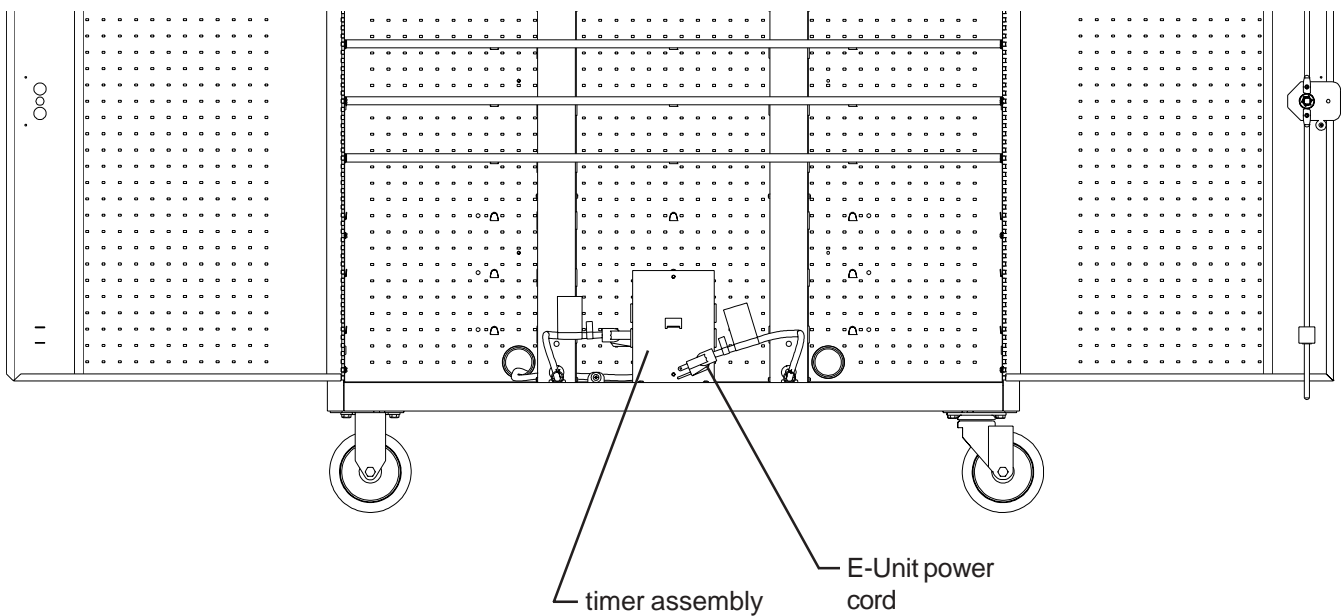

Front View

Carefully unplug the power cords of the E-Units from the timer assembly (see Front View).

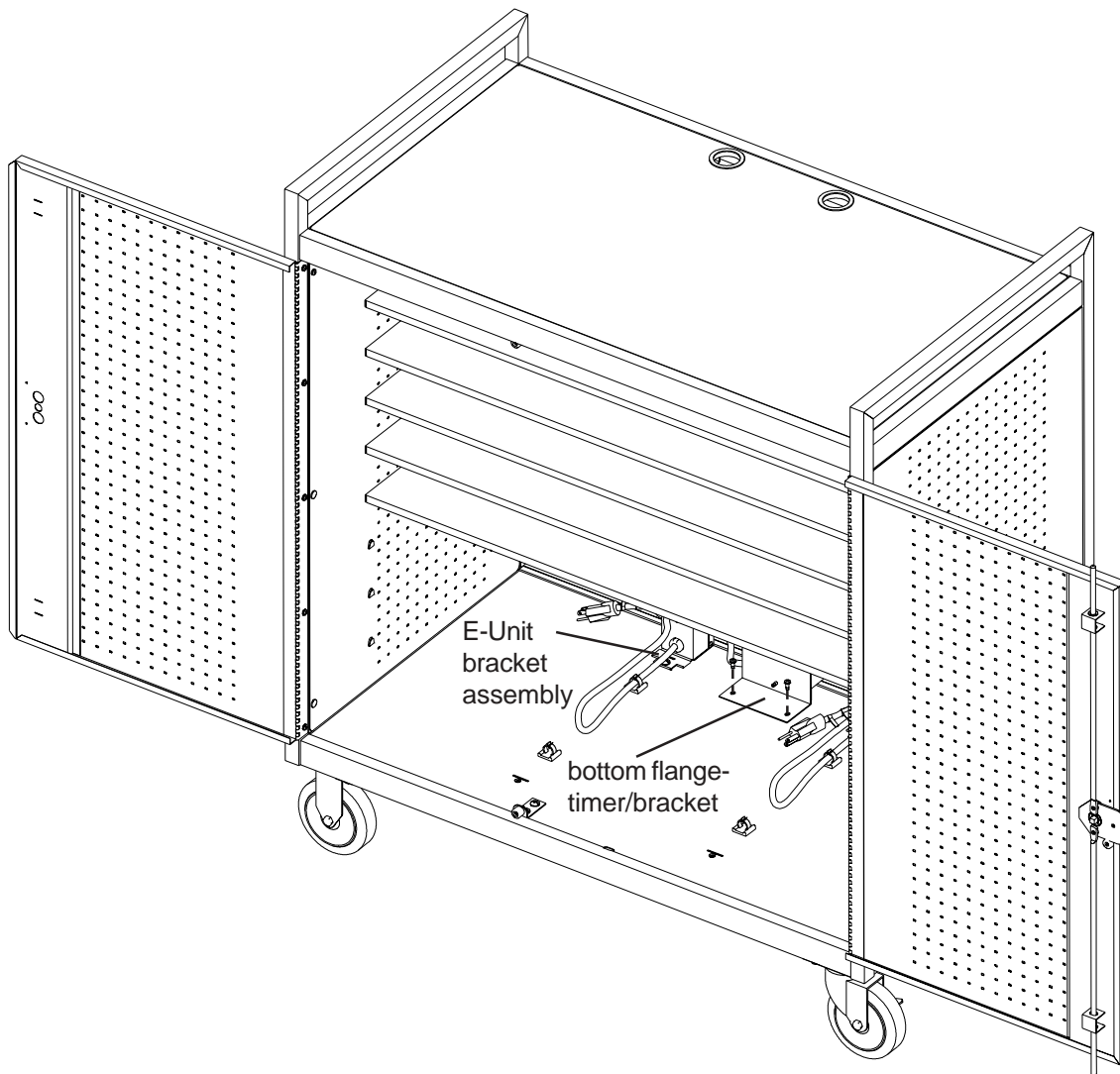

Step 3

Remove 2 screws from bottom flange (securing bracket to bottom of cart) and remove timer/bracket assembly. The E-Unit bracket assembly shown above, will need to be removed (with a philips screwdriver) to allow the E-Unit to swing back. This will allow the timer cord plug to pass between the E-Unit and rear panel.

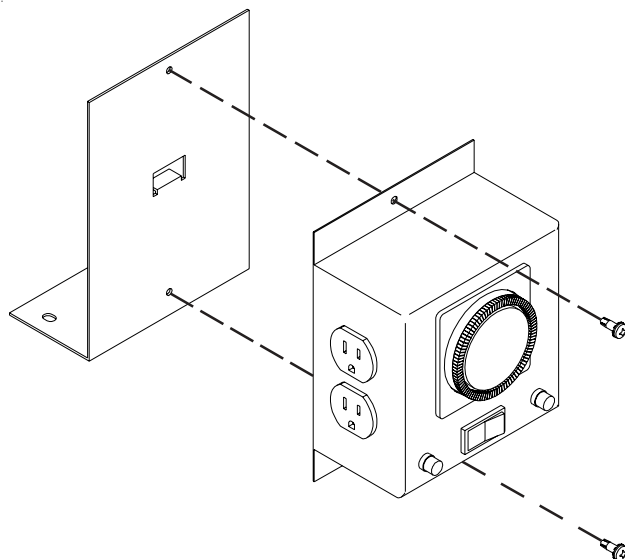

Step 4

Remove 2 screws that secure timer to bracket.



Timer vents & bracket must be attached as shown.

Step 5

Install bracket to replacement timer with 2 nuts. Adjust timer dial to current time. If necessary, adjust timer charging times to match the original timer.

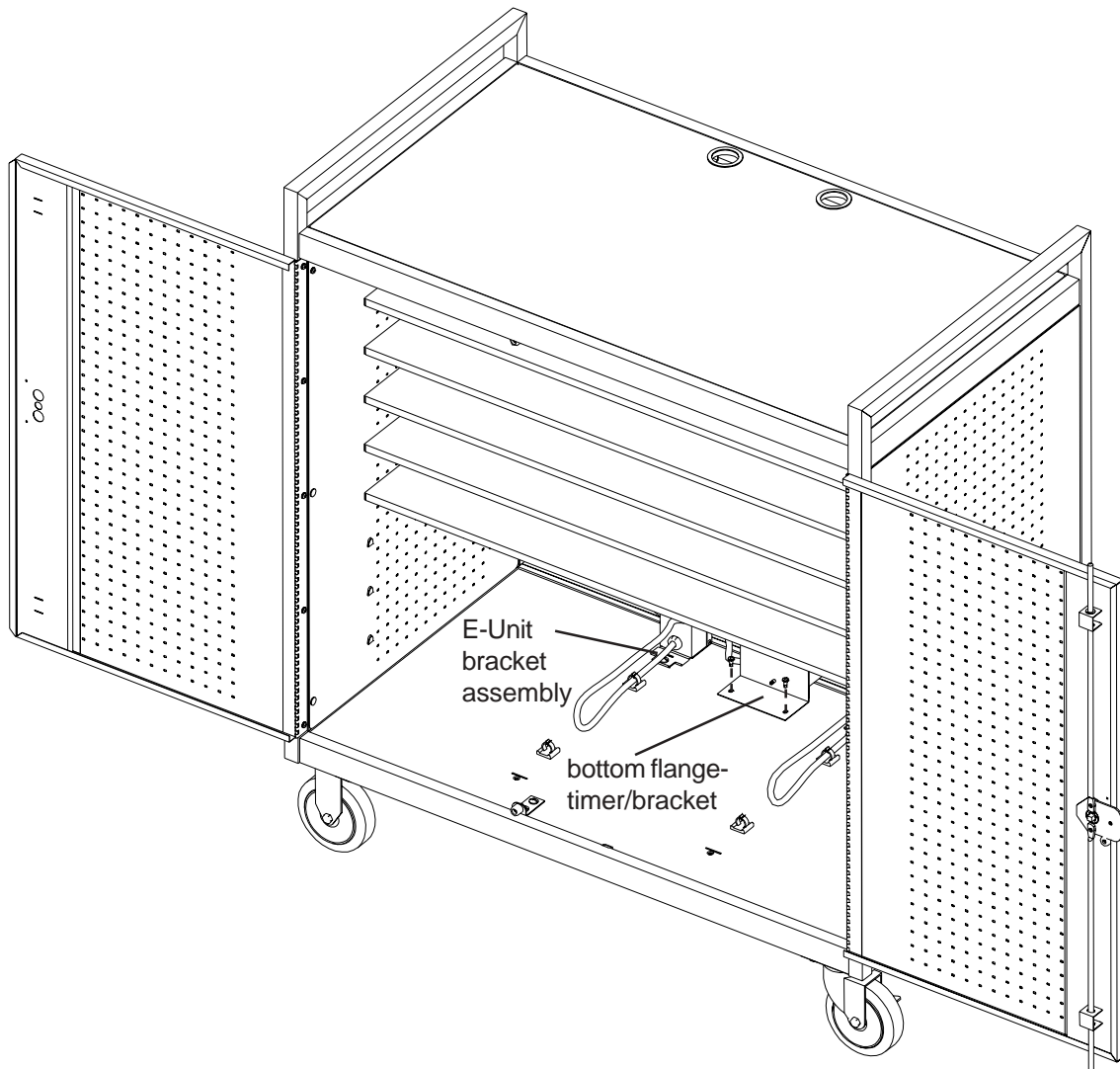

Step 6

Install replacement timer/bracket assembly onto bottom, rear of cart with 2 screws. Feed the power cord from the timer out the grommated hole (with cord wrap bracket located above cutout). Make sure timer face is aligned with rear panel cutouts. Swing the E-Unit back into position and reinstall bracket assembly. Plug in the E-Units power cords into the bottom outlets of the timer assembly.

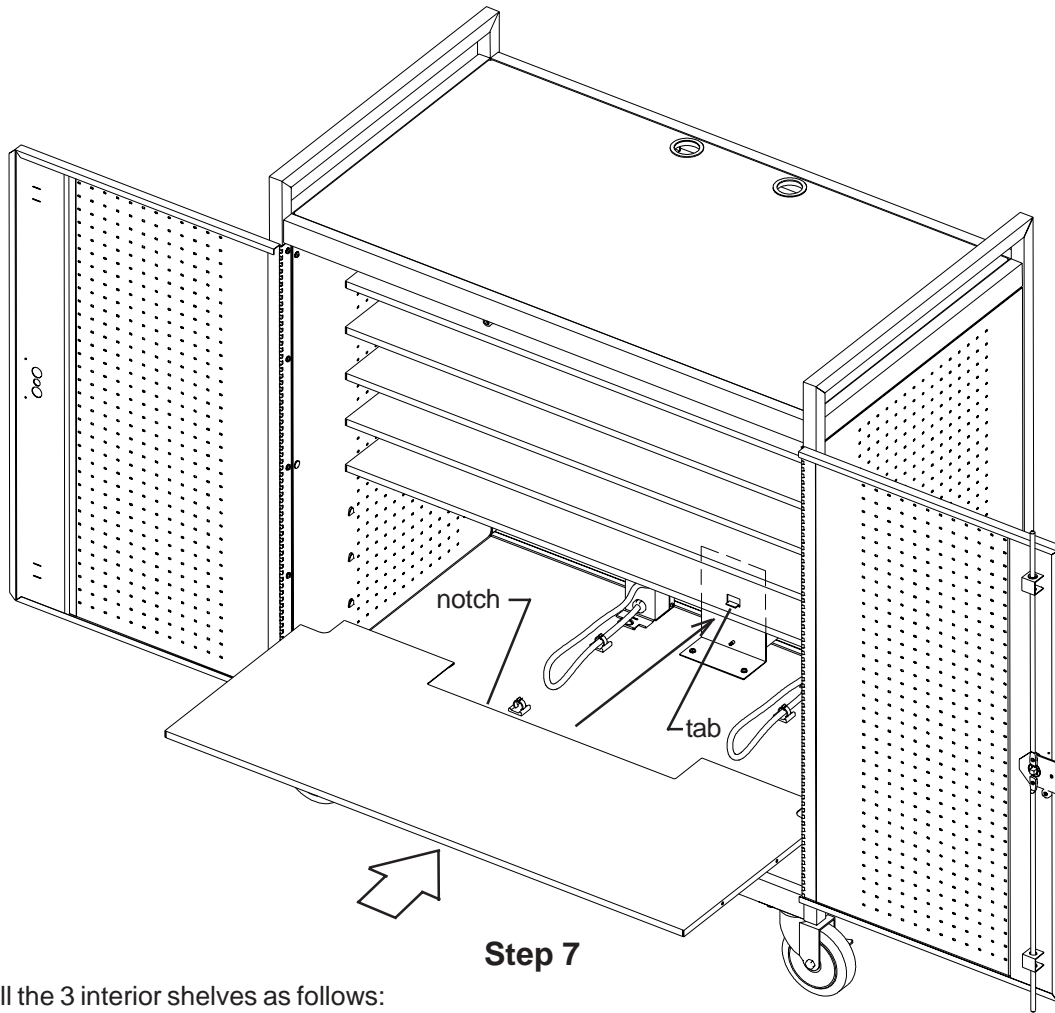

Step 7

Reinstall the 3 interior shelves as follows:

1. Carefully slide in the shelf with notch at the **bottom** position (the notch will rest on the bracket tab).
(Make sure that the shelf flanges are ALL seated into the mounting tabs.)
2. Slide in remaining 2 shelves into position as the bottom shelf.

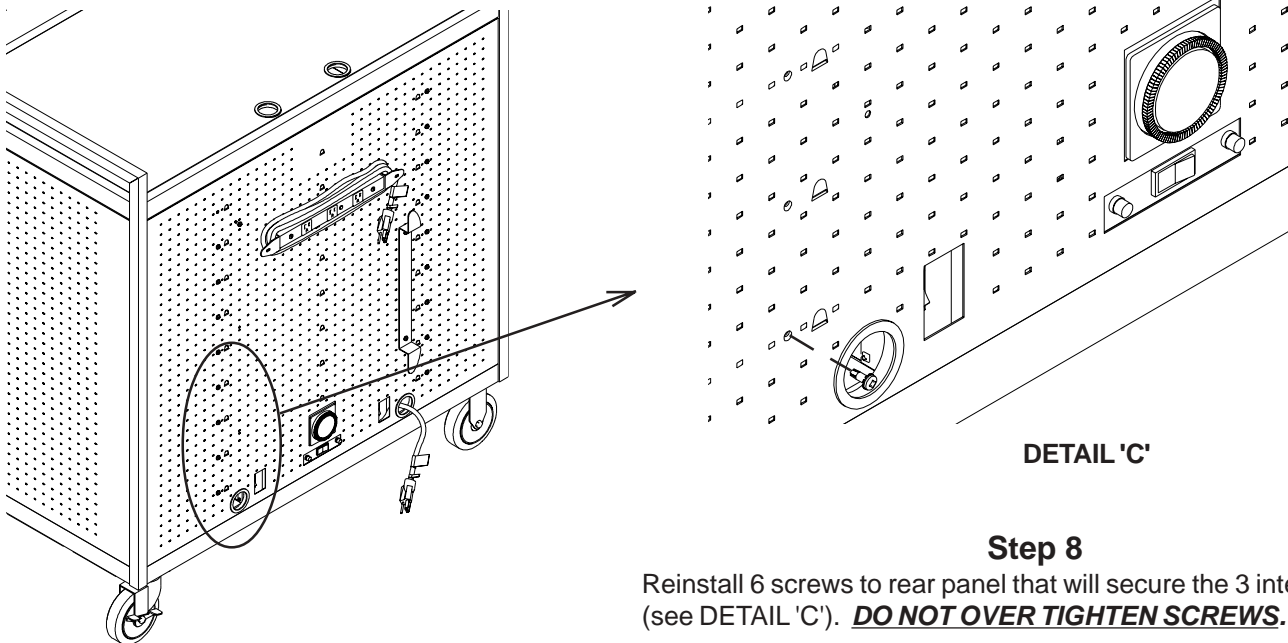

DETAIL 'C'

Step 8

Reinstall 6 screws to rear panel that will secure the 3 interior shelves (see DETAIL 'C'). ***DO NOT OVER TIGHTEN SCREWS.***

Installation is now complete and ready for use.

NOTE:

**UNPLUG CART (TIMER) POWER CORD FROM
POWER SOURCE BEFORE STARTING**

**TIMER REPLACEMENT:
'E-UNIT AT FRONT LOCATION'**

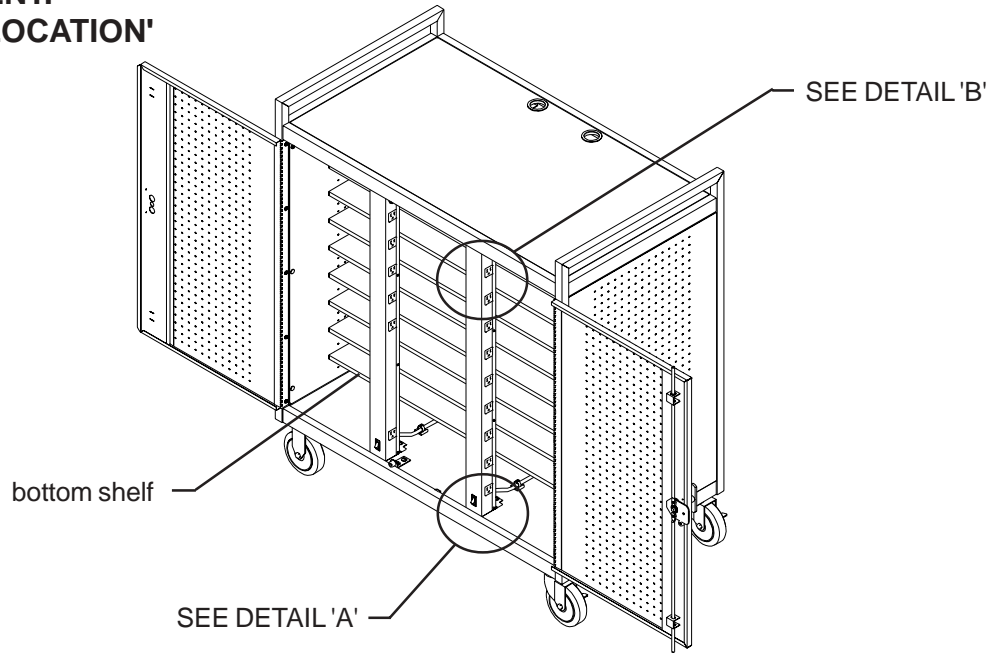

Step 1

Open both front doors of cart to access E-Units. From underneath the bottom shelf, carefully unplug the power cords of the E-Units from the timer assembly (see Front View) and unclip the power cords from the 4 clips located at the bottom panel of the cart. Loosen the screw holding the E-Unit bracket assembly and remove all 4 bracket assemblies (see DETAILS 'A' and 'B').

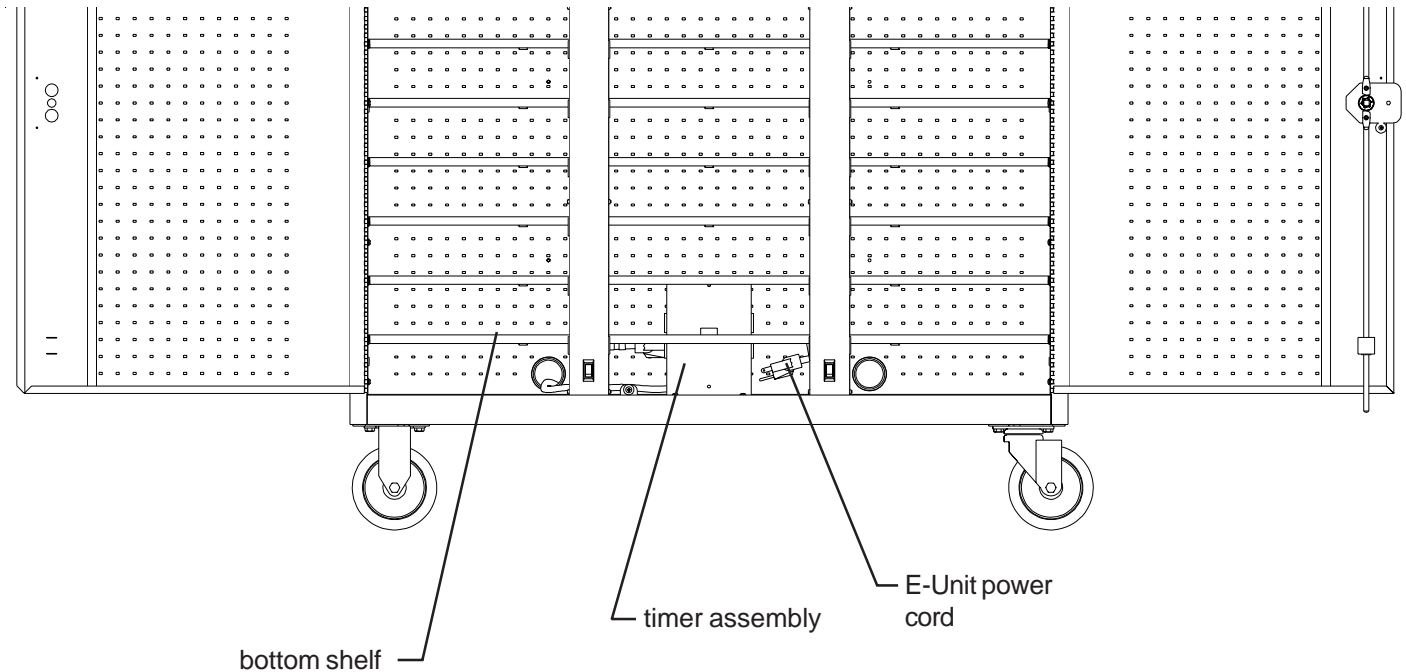

Front View

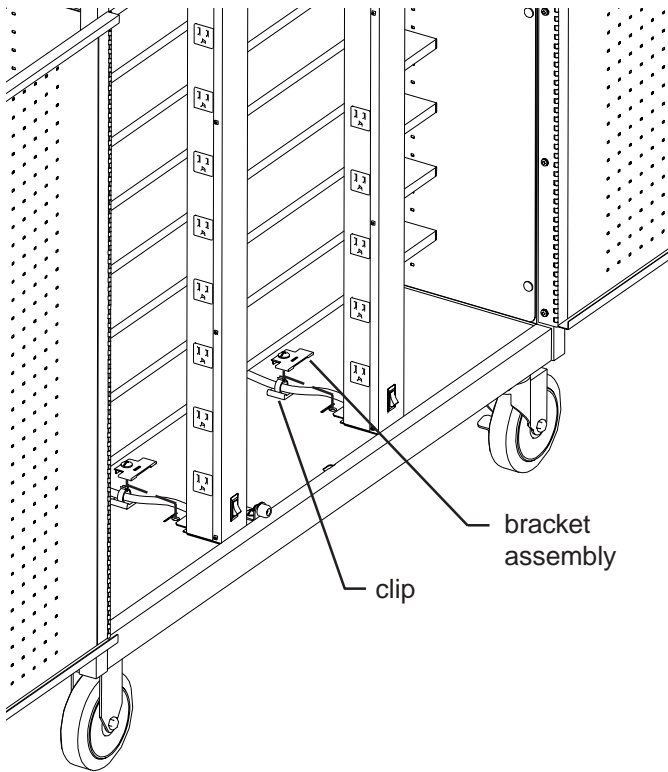

DETAIL 'A'

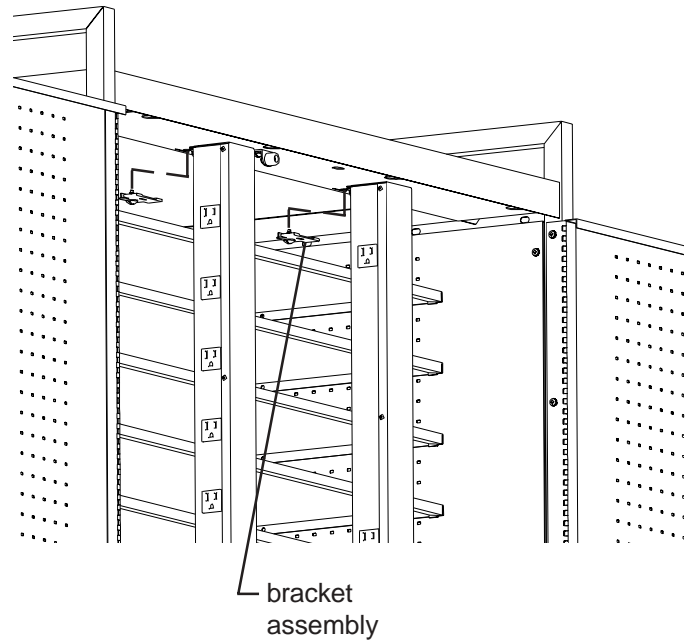

DETAIL 'B'

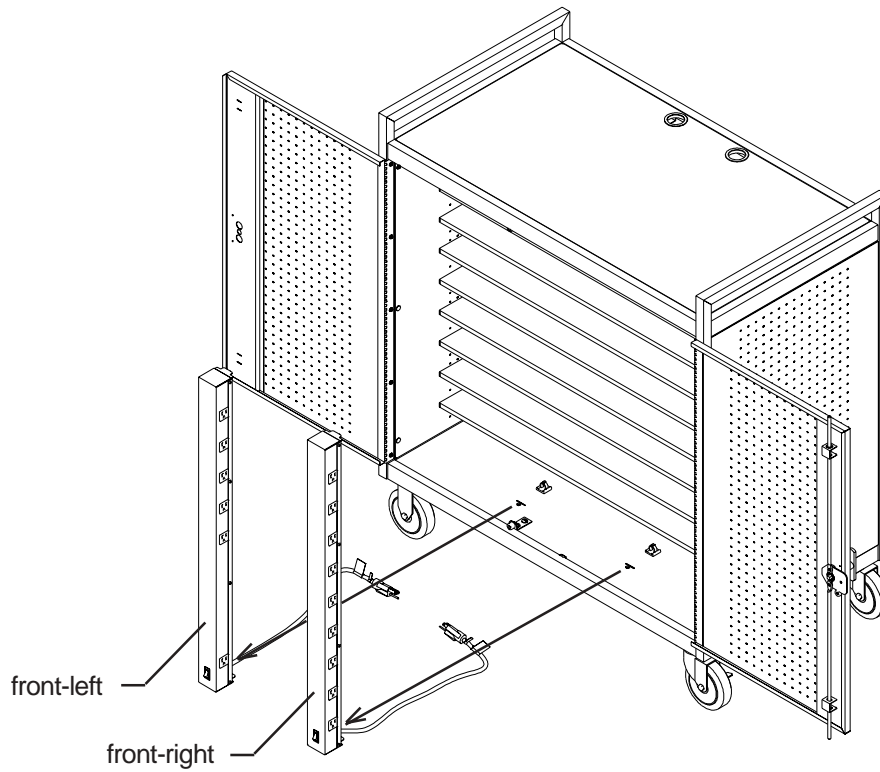

Step 2

Remove **front-left** E-Unit by gripping the top and tilt it side ways until it clears the underside of the cart interior shelf channel and set it aside.

Remove **front-right** E-Unit by gripping the top and tilt it side ways until it clears the underside of the cart interior shelf channel and set it aside.

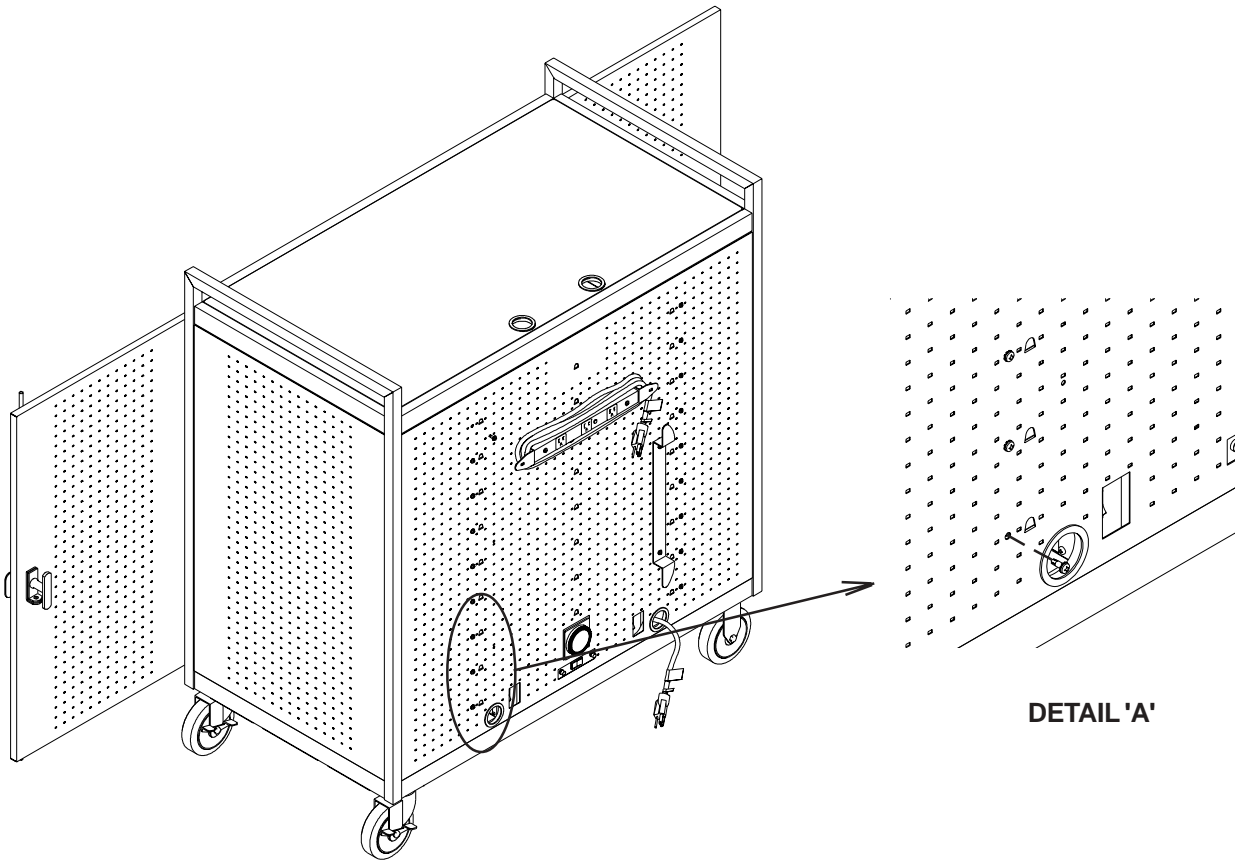

DETAIL 'A'

Step 3

Remove 6 screws (2 per shelf) from rear panel that secure the 3 **bottom** interior shelves (see DETAIL 'A').

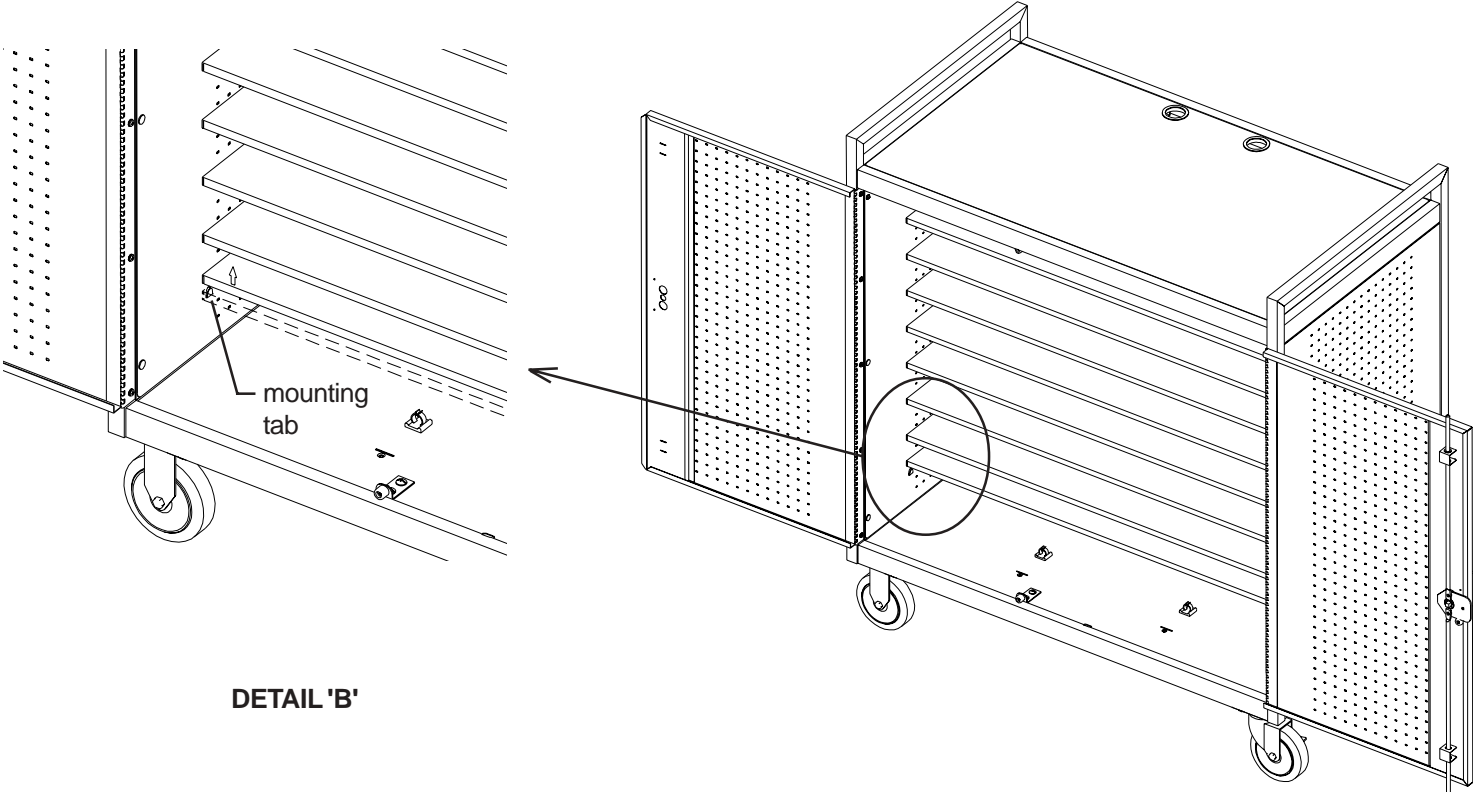

DETAIL 'B'

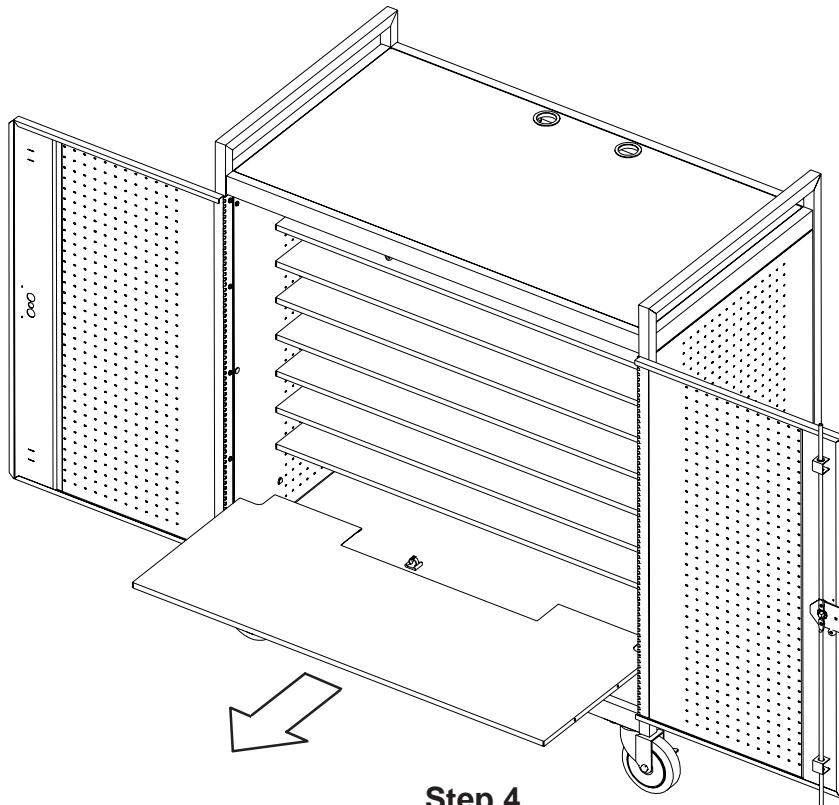

Step 4

With both doors open, remove the 3 bottom interior shelves by carefully pushing upward (to release shelf from mounting tabs) shown in Detail 'B', then carefully sliding out. Set each shelf aside.

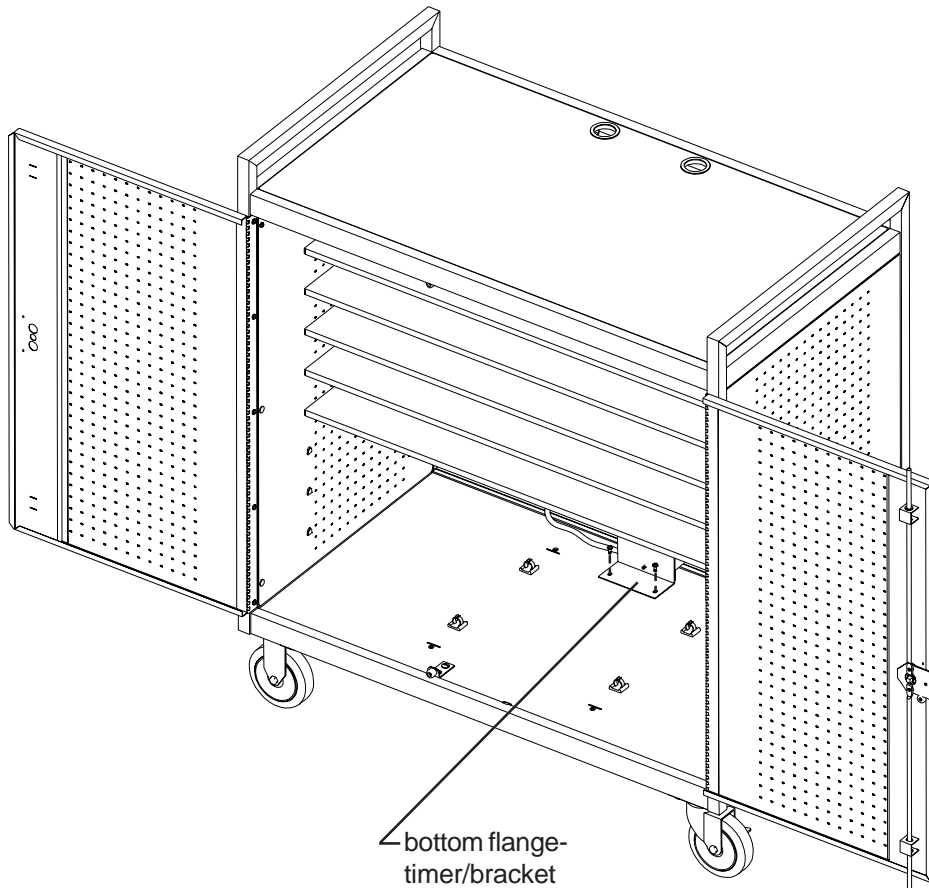

Step 5

Remove 2 screws from bottom flange (securing bracket to bottom of cart) and remove timer/bracket assembly.

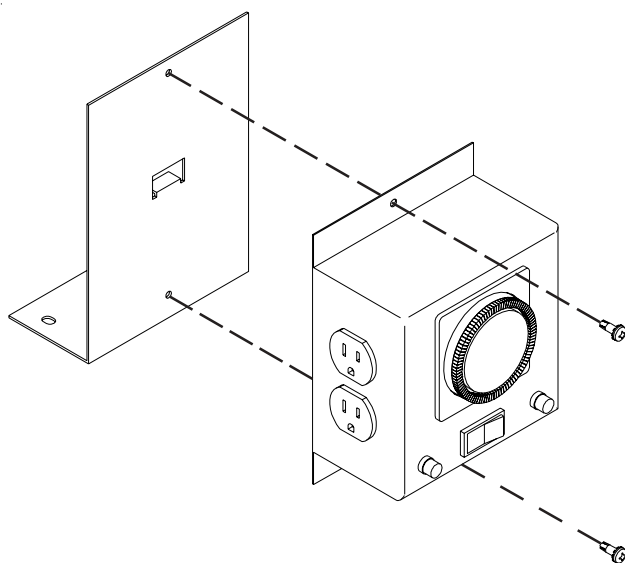

Step 6

Remove 2 screws that secure timer to bracket.



Timer vents & bracket must be attached as shown.



Step 7

Install bracket to replacement timer with 2 nuts. Adjust timer dial to current time. If necessary, adjust timer charging times to match the original timer.

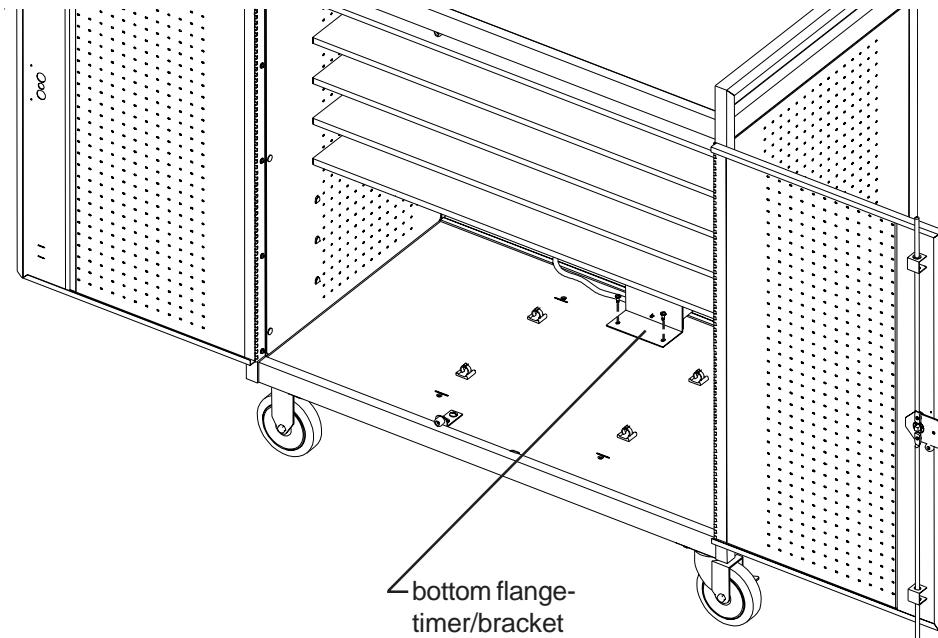

Step 8

Install replacement timer/bracket assembly onto bottom, rear of cart with 2 screws. Feed the power cord from the timer out the grommeted hole (with cord wrap bracket located above cutout). Make sure timer face is aligned with rear panel cutouts.

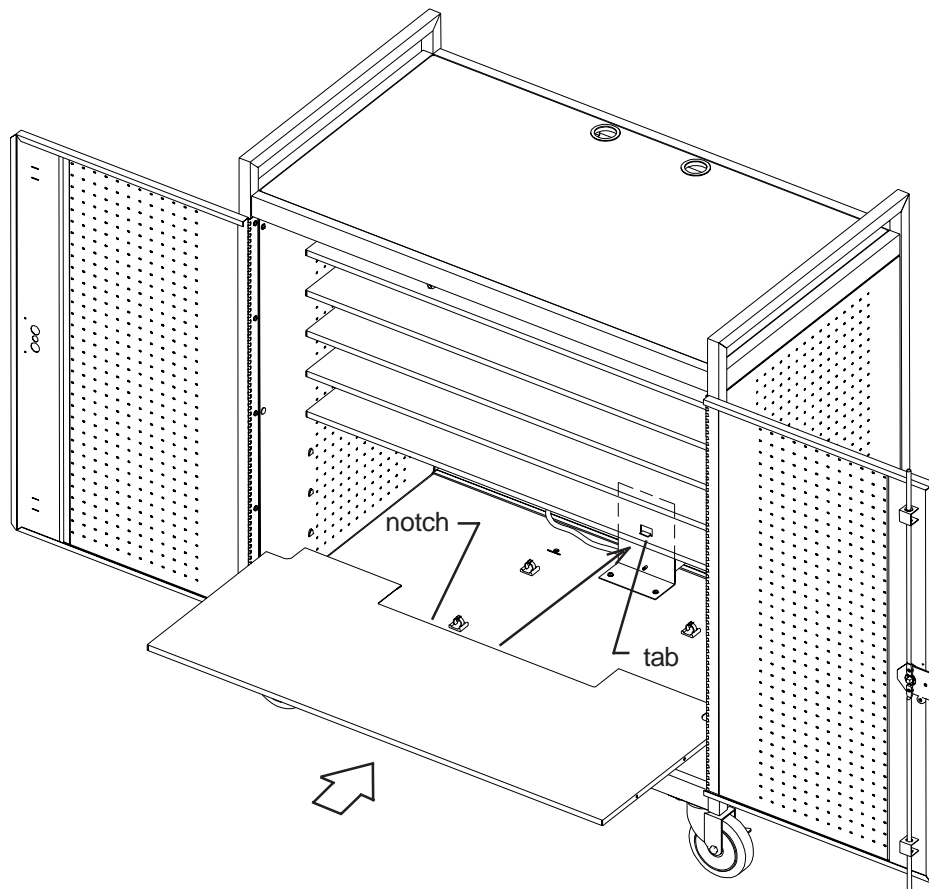

Step 9

Reinstall the 3 interior shelves as follows:

1. Carefully slide in the shelf with notch at the **bottom** position (the notch will rest on the bracket tab). (Make sure that the shelf flanges are ALL seated into the mounting tabs.)
2. Slide in remaining 2 shelves into position as the bottom shelf.

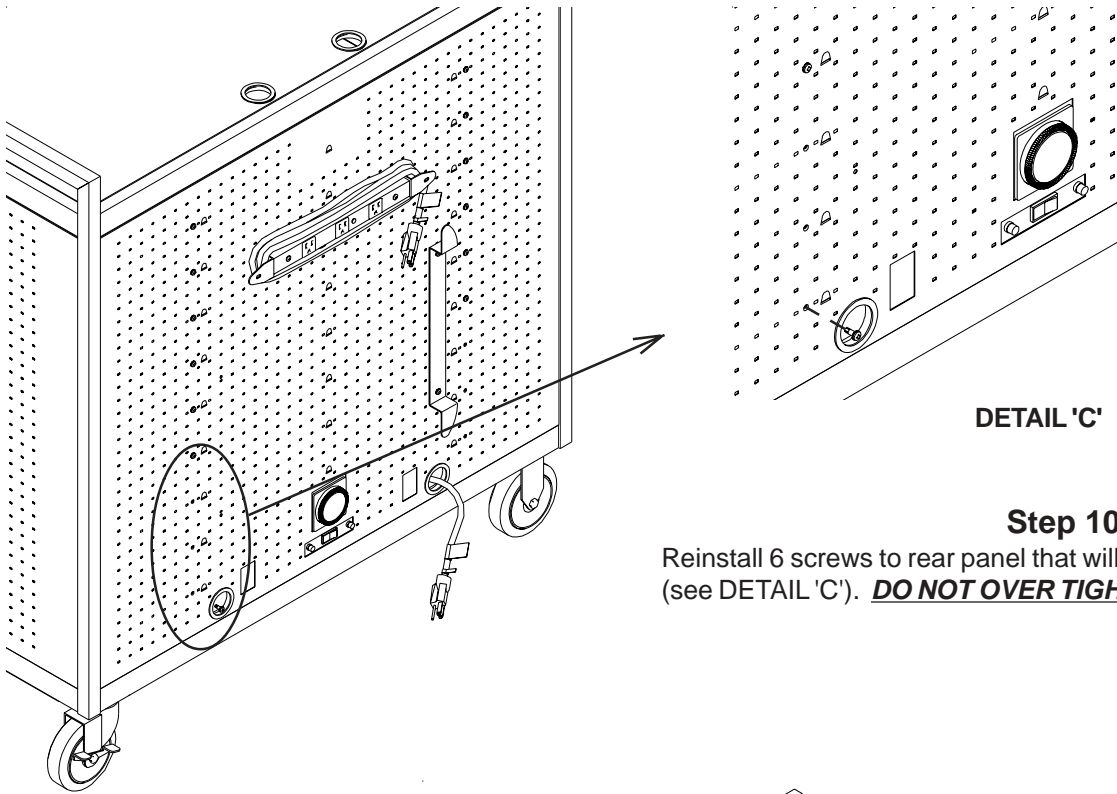

DETAIL 'C'

Step 10

Reinstall 6 screws to rear panel that will secure the 3 interior shelves (see DETAIL 'C'). **DO NOT OVER TIGHTEN SCREWS.**

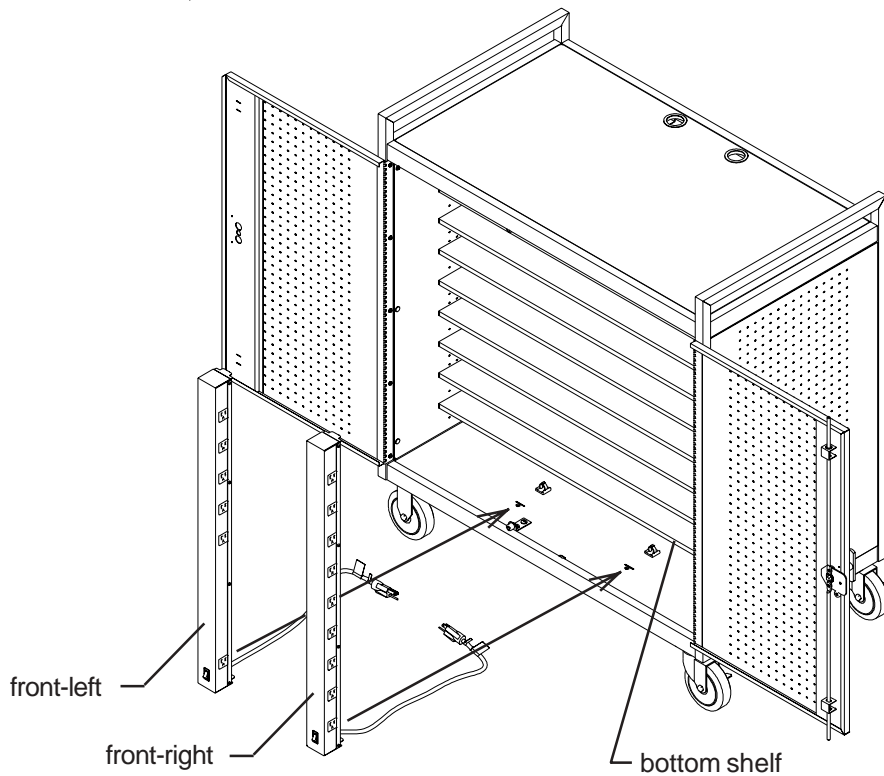

Step 11

Carefully reinstall E-Units into position by placing bottom in first and tilting it in sideways to the top (underneath the channel bracket of the cart top panel).

When repositioned correctly, the E-Units power switch should face the front.

Reinstall the E-Unit bracket assemblies (make sure that the top flange of the E-Unit is aligned with the slot in the bracket assembly) and tighten screws securely.

Plug in the E-Unit power cords into the bottom outlets of the timer assembly (located underneath bottom shelf).

Press E-Unit power cords into the two wire clips located (in line, behind E-Units) on the bottom of cart.

Installation is now complete and ready for use.

LABEL INSTALLATION:

peel off and attach corresponding labels to shelves and E-Units.

AUX. 1	AUX. 2	AUX. 3	AUX. 4
AUX. 5	AUX. 6	1	2
3	4	5	6
7	8	9	10
11	12	13	14
15	16	17	18
19	20	21	22
23	24	25	26
27	28	29	30

suggested installation of labels

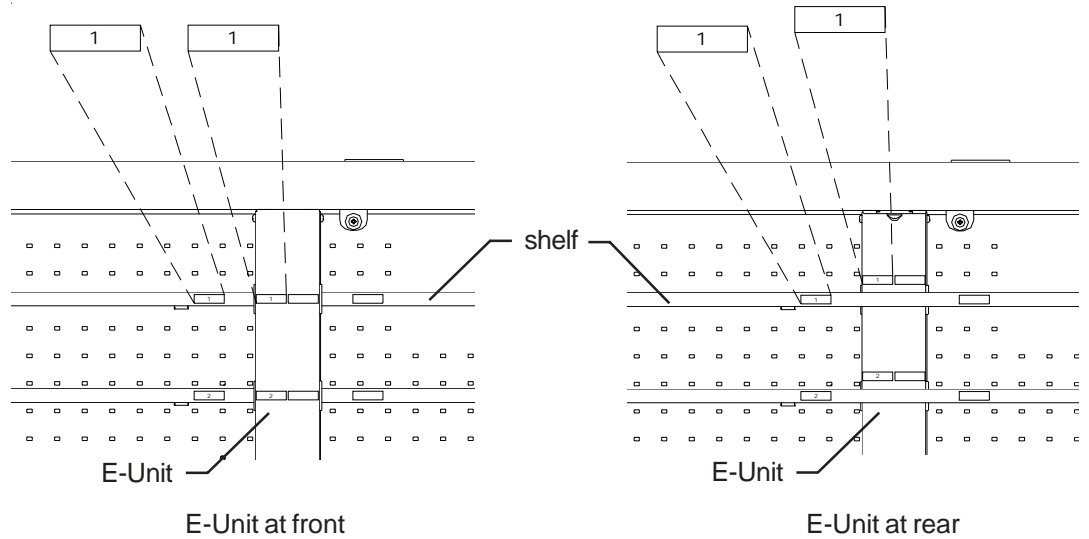

suggested label direction

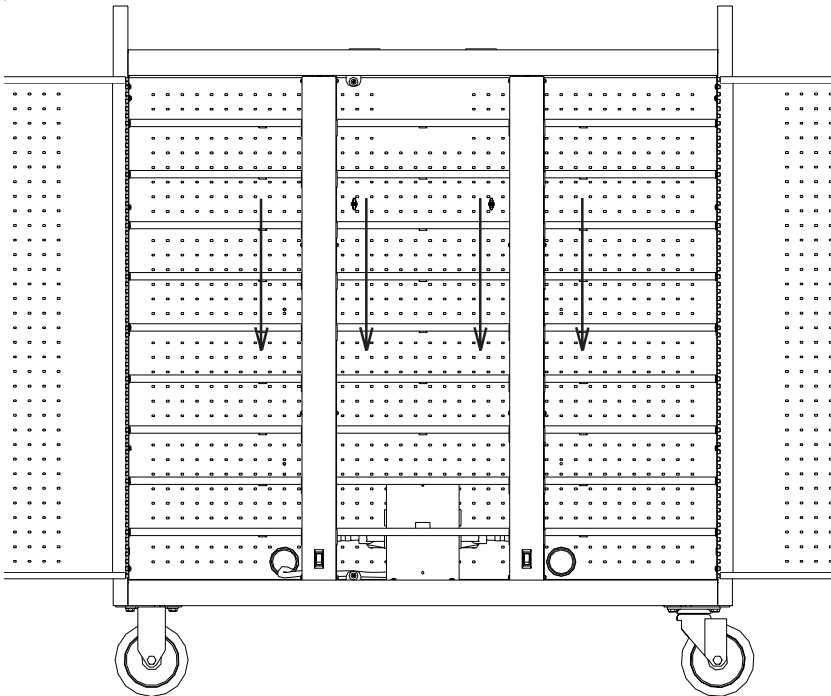

PAD LOCK - DOOR:

Resettable Combination Padlock

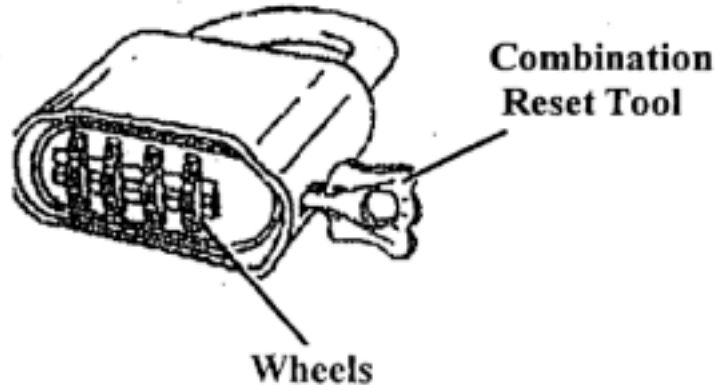

Open Lock The First Time

- 1) Set the combination to 0-0-0-0
- 2) Depress shackle and pull open.

To Set You Own Combination

- **REMEMBER:** Combination can only be set when lock is open.
- 1) Insert "reset" tool (included in package) in hole on side of lock.
 - 2) Push key in and turn key 90 degrees in either direction.
(Key automatically stays in this position).
Failure to exert force while pushing key in will result in a failed attempt to set or reset combination.
 - 3) Set wheels to desired combination.
 - 4) Turn and remove reset tool. Lock is now set to new combination.
****BE SURE TO RECORD YOUR COMBINATION.**
 - 5) To lock scramble the wheels and close the shackle.
 - 6) To reopen dial your combination and depress shackle.

Touchboards

205 Westwood Ave, Long Branch, NJ 07740
Phone: 866-94 BOARDS (26273) / (732)-222-1511
Fax: (732)-222-7088 | E-mail: sales@touchboards.com