

ECILS1 / ECILS1FF

Mobile Computer Workstation

Assembly Instructions

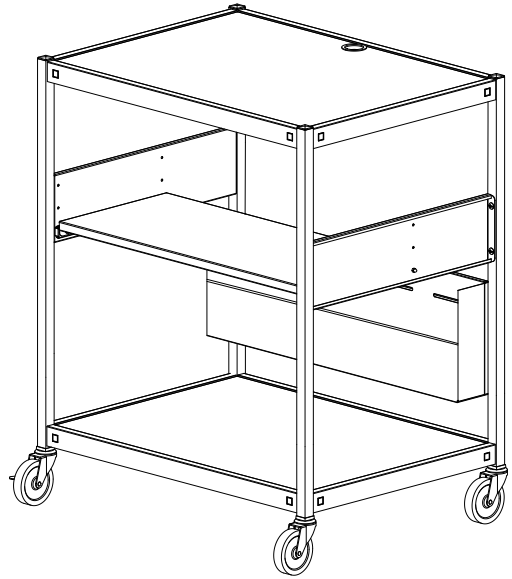

PARTS LIST

Qty	Part#	Description
1	022-2695	Top Shelf w/ grommet hole
1	010-4513	Slide Out Shelf
1	010-3953	Bottom Shelf
2	010-4506	Shelf Support Brackets
4	022-3085	Leg Assemblies
1	022-2309	Wire Tray
2	015-0002	4" Casters w/o Lock
2	015-0003	4" Casters w/ Lock
1	030-1191	14" Full Extension Slide
1	ECF6	Electrical Unit - ECILS1FF ONLY

HARDWARE LIST

Ref	Qty	Part#	Description
AA	16	030-0300-21S	5/8" Square Head Bolts
BB	16	030-0002	5/16-18 Hex Serrated Nuts
CC	12	030-0304	1/4-20 x 5/8" Combo Screws
DD	8	030-1228	8-32 x 1/4" Combo Truss Hd Screws
EE	4	030-1203	#8-32 Acorn Nuts
FF	2	020016	#6-32 Hex Nuts - ECILS1FF ONLY
GG	2	020017	#6-32 x 1/4" Screws - ECILS1FF ONLY
HH	4	02236	8-32 Hex Flange Nuts
	1	010-1106	Hex Wrench

TOOLS REQUIRED

- Hex Wrench (Provided)
- Phillips Screwdriver
- Rubber Mallet

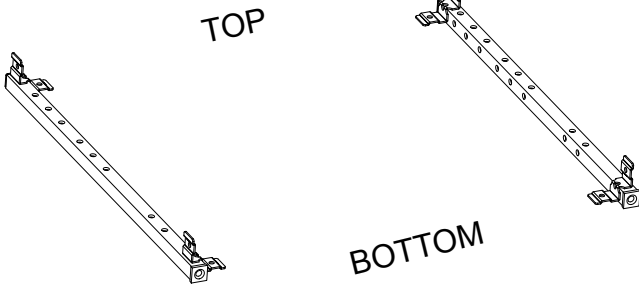
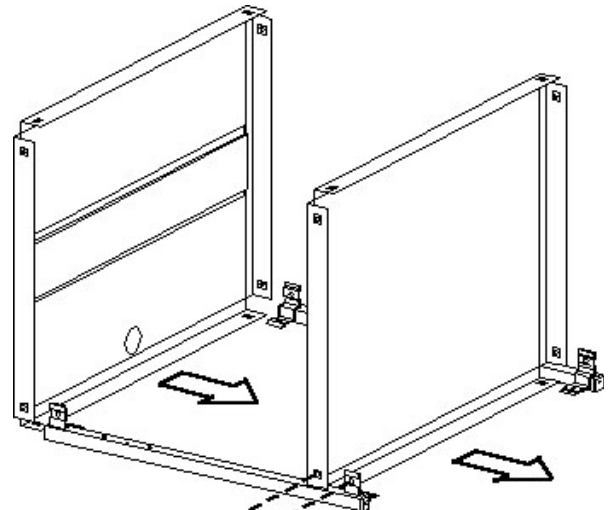

FIGURE 1



Align shelf embossed mounting hole with leg mounting bracket. 2 corners each shelf.

FIGURE 2

STEP 1

Lay 2 legs on a carpeted surface as shown in **Figure 1**. Slide the top shelf (with hole at rear) and bottom shelf (with 4 square holes toward front) onto the legs so that the brackets are inside the shelves (**see Figure 2**).

Align shelf embossed mounting hole with leg mounting bracket. 2 corners each shelf.

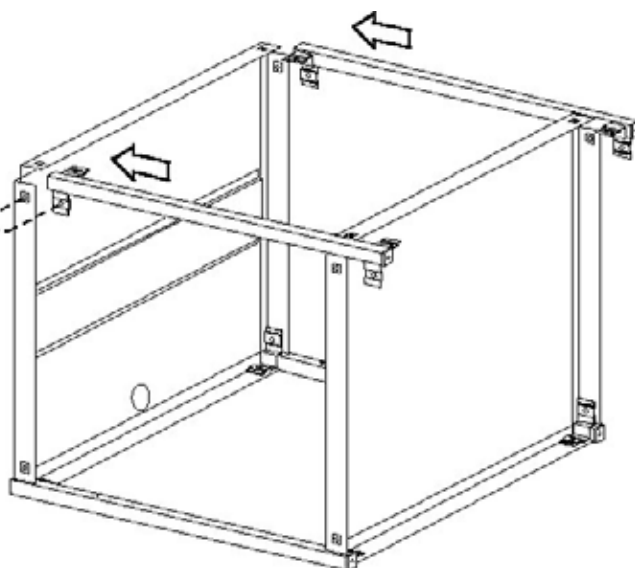

STEP 2

Slide the front legs (they are stamped “LF” and “RF”) onto the shelves so that the brackets are inside the shelves.

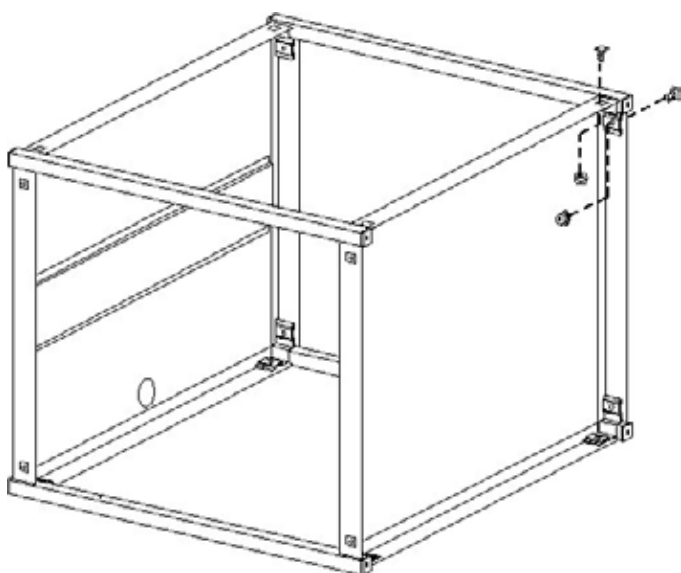

STEP 3

Secure shelves and legs together with bolts (AA) and nuts (BB) in each corner as shown.

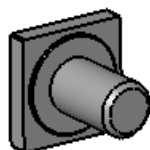

AA



BB

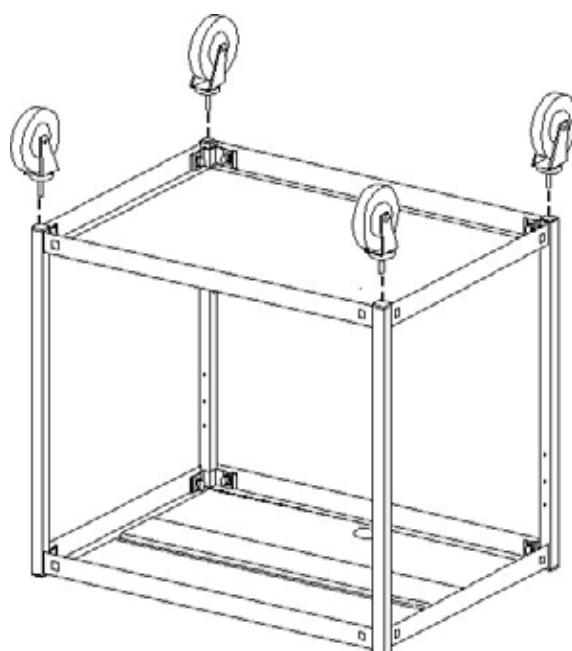

STEP 4

Insert each caster into the bottom of each leg. If caster does not insert easily, use a rubber mallet to tap caster in place. Once casters are **SECURELY** in place, stand unit upright.

SHELF SUPPORT BRACKET

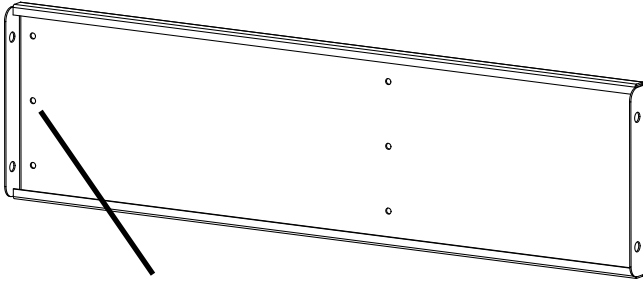

THESE HOLES MUST FACE FRONT
EDGE OF CART. (SIDE OPPOSITE
THE GROMMET)

DETAIL 'A'

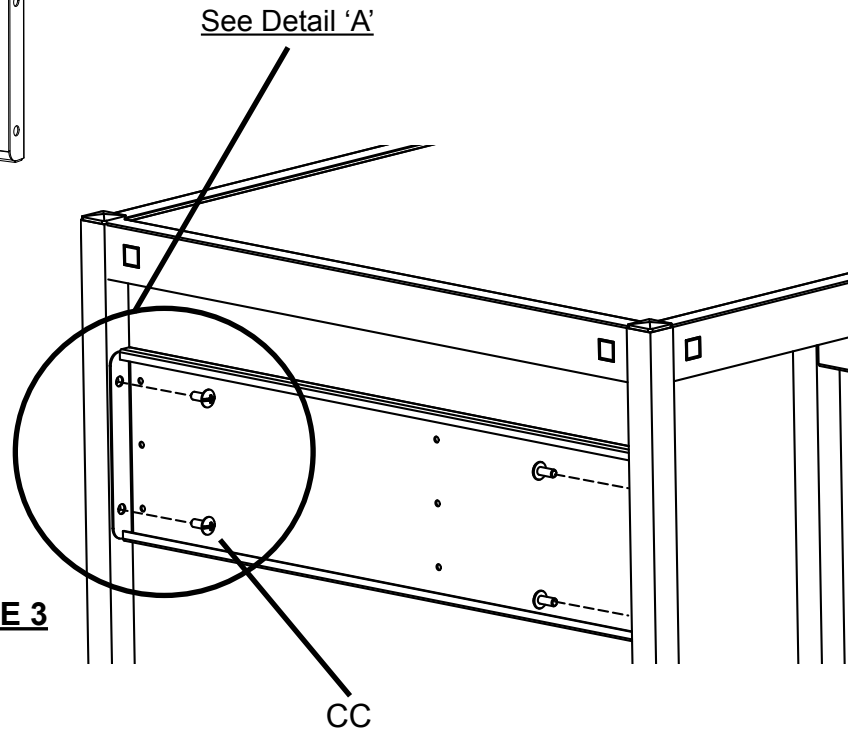

FIGURE 3

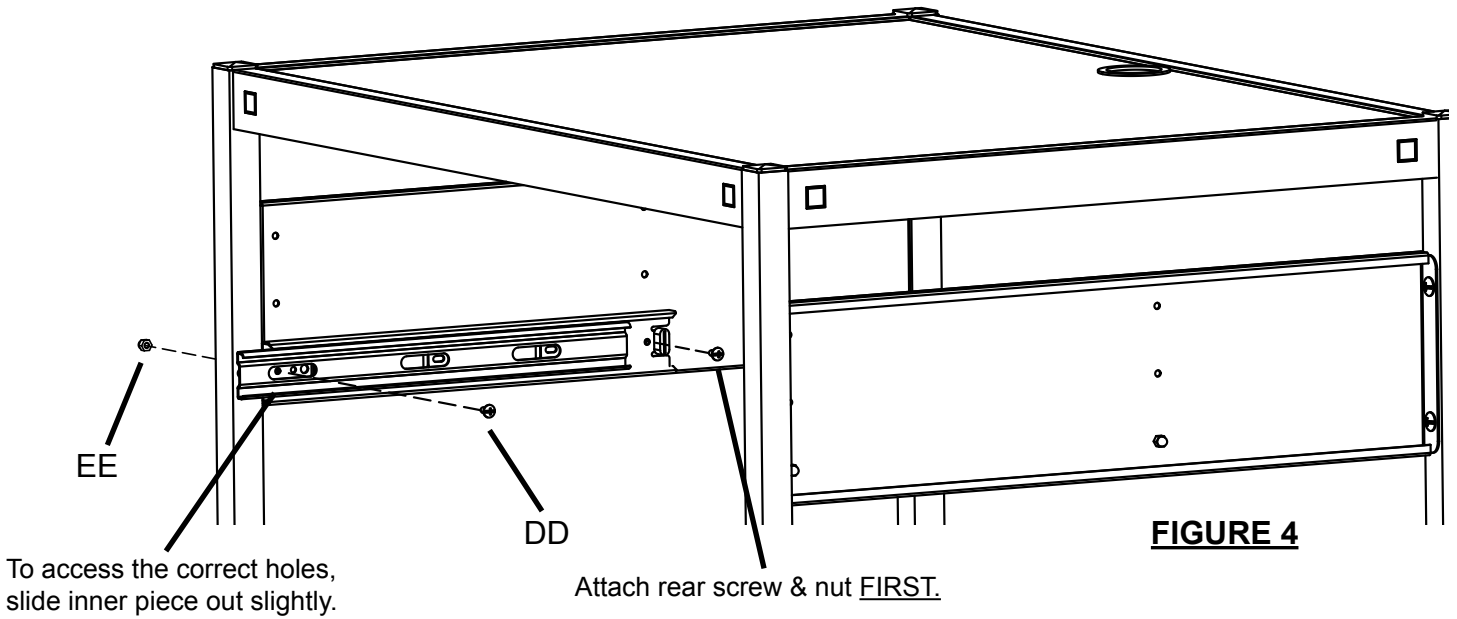
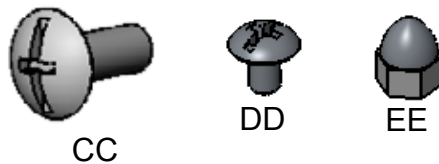

FIGURE 4

STEP 5

Attach shelf support brackets to upper portion of rear legs with screws (CC) as shown in **FIGURE 3**. Refer to Detail 'A' for correct position of bracket. Then separate each slide and attach the outer section to the inside of each shelf support bracket with screws (DD) and nuts (EE) as shown in **FIGURE 4**. **NOTE:** Attach rear screw and nut first.



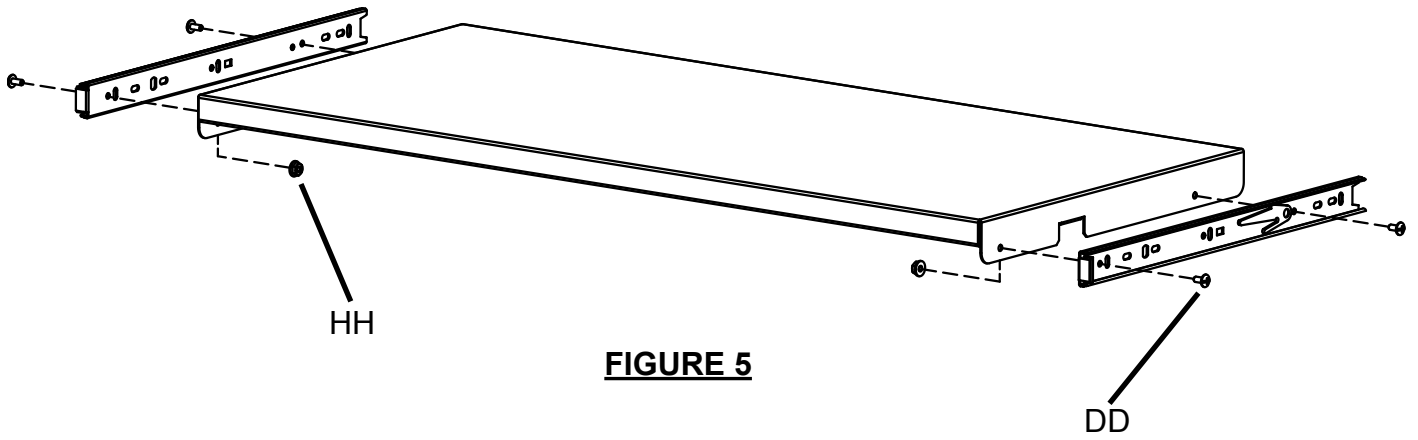

FIGURE 5

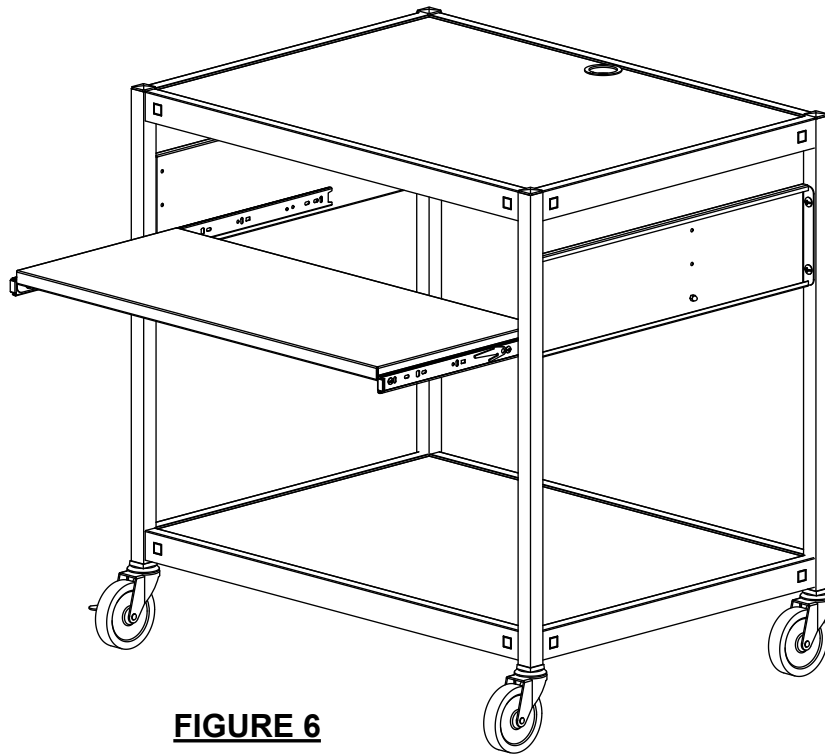

FIGURE 6

STEP 6

Attach the remaining slide pieces to the pull out shelf with screws (HH) and nuts (JJ) as shown in **FIGURE 5**. Then slide shelf into cart as shown in **FIGURE 6**.



HH

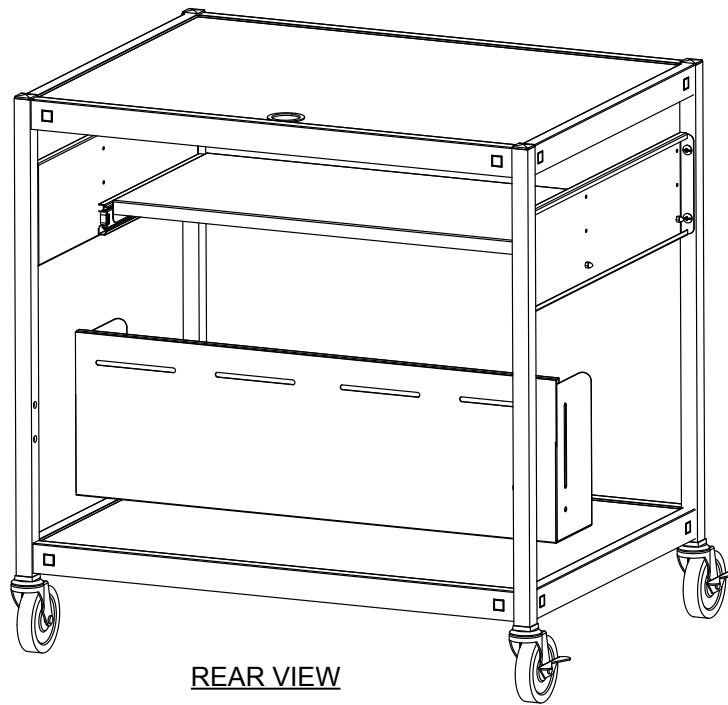

REAR VIEW

STEP 7

Slide the cord bin between the rear legs and align slotted holes of the cord bin sides with the (2) mounting holes of the legs. Position the cord bin per Detail 'B' to obtain desired height and install four screws (CC).

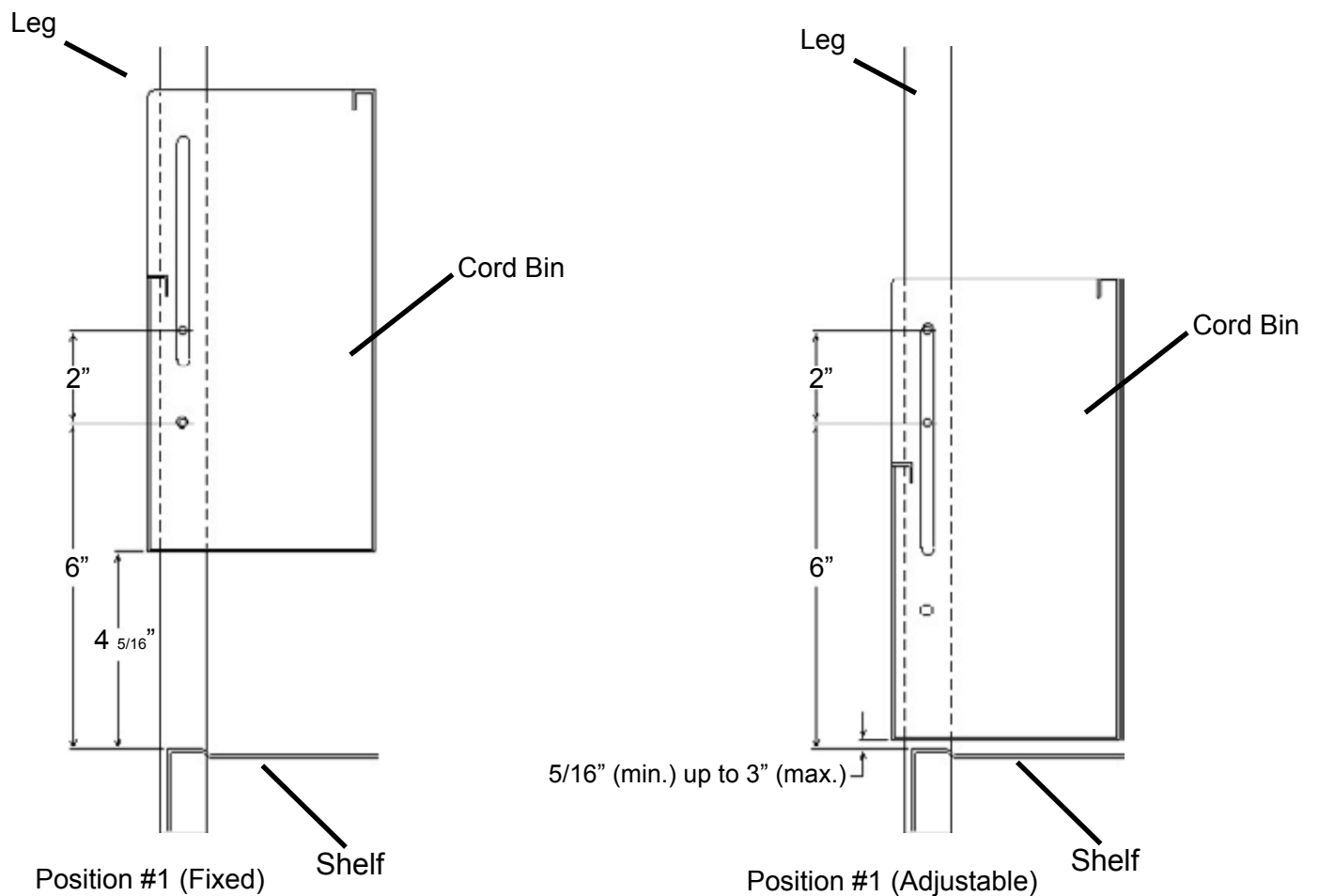

Detail 'B'

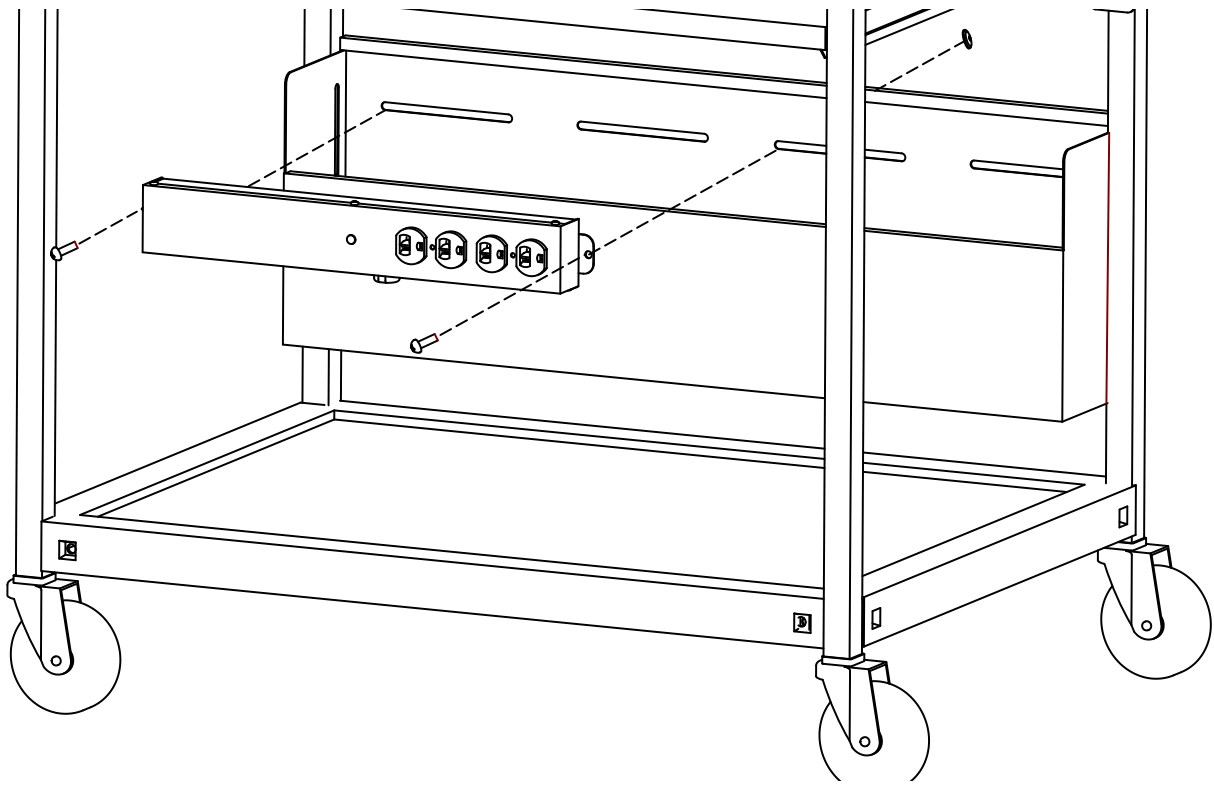

STEP 8

Align the CFPS electrical unit with the slots in the inside of the cord bin.
Secure the unit in place with screws (FF) and nuts (GG) as shown.



FF



GG

Bretford
11000 Seymour Avenue
Franklin Park, IL 60131
TEL: 847.678.2545
800.521.9614
FAX: 847.678.0852
800.343.1779

Bretford Ltd.
2 Etongate
110 Windsor Road, Slough
Berkshire SL1 2JA England
TEL: 011 44 17 5353 9955
FAX: 011 44 17 5353 9478