

PowerSync Station 20

Mounting Instructions



Mounting on a Desktop or Countertop

The PowerSync Station 20 can be mounted to a solid surface, providing added security for your iPad devices.

Mounting to a solid surface requires:

- PowerSync Station 20 for iPad.
- Surface mounting bracket (included)
- Mounting screws or other anchors appropriate for your surface (not included). The holes in the Surface Mounting Bracket are 9/32 inch (7mm) diameter.
- Two self-tapping screws (included) for securing the PowerSync Station 20 to the Mounting Bracket.
- #2 phillips screwdriver

In addition, when surface mounted, the PowerSync Station 20 allows up to three PowerSync Station 20 units to be stacked.

Stacking two or three PowerSync Station 20 units requires:

- Additional PowerSync Station 20 (purchase separately)
- Stacking Bracket (included)
- Five self-tapping screws (included) - three for lower unit, two for upper unit.

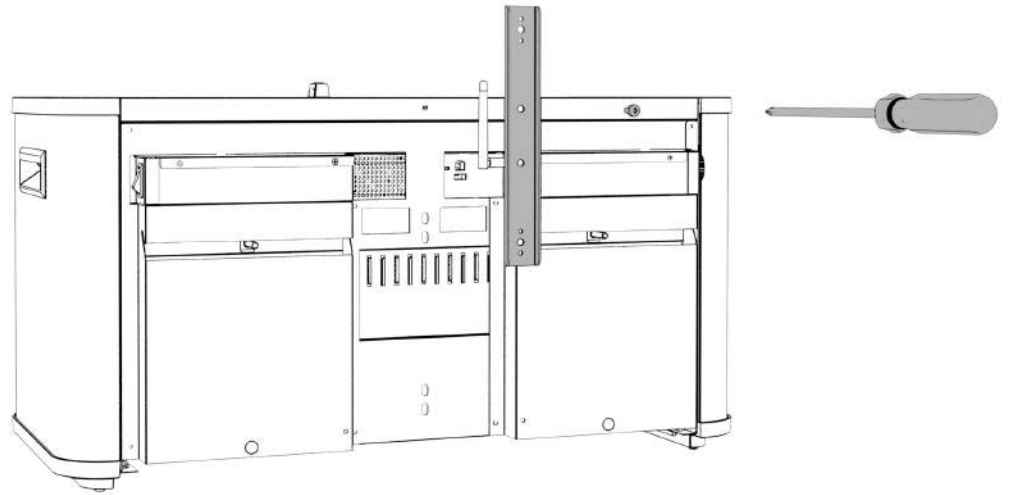

1

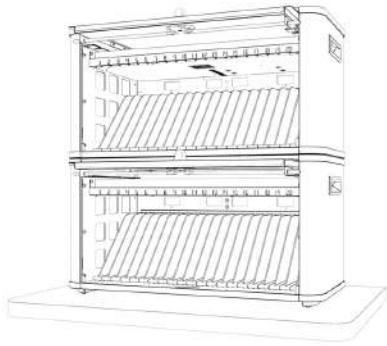

?

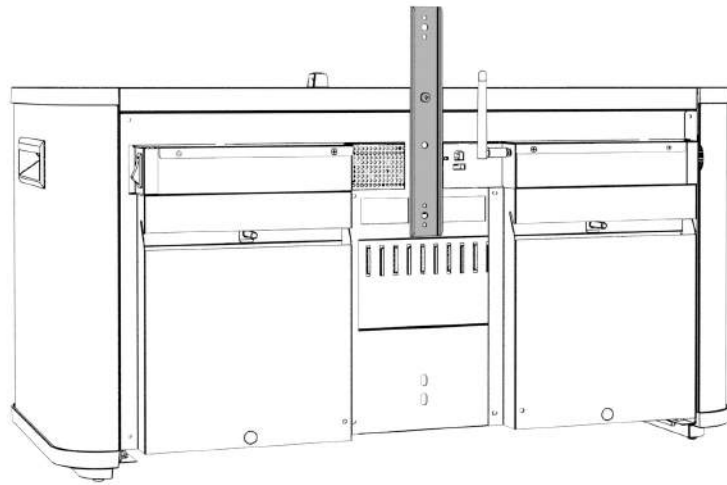

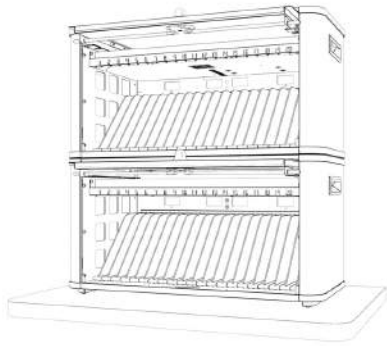

?

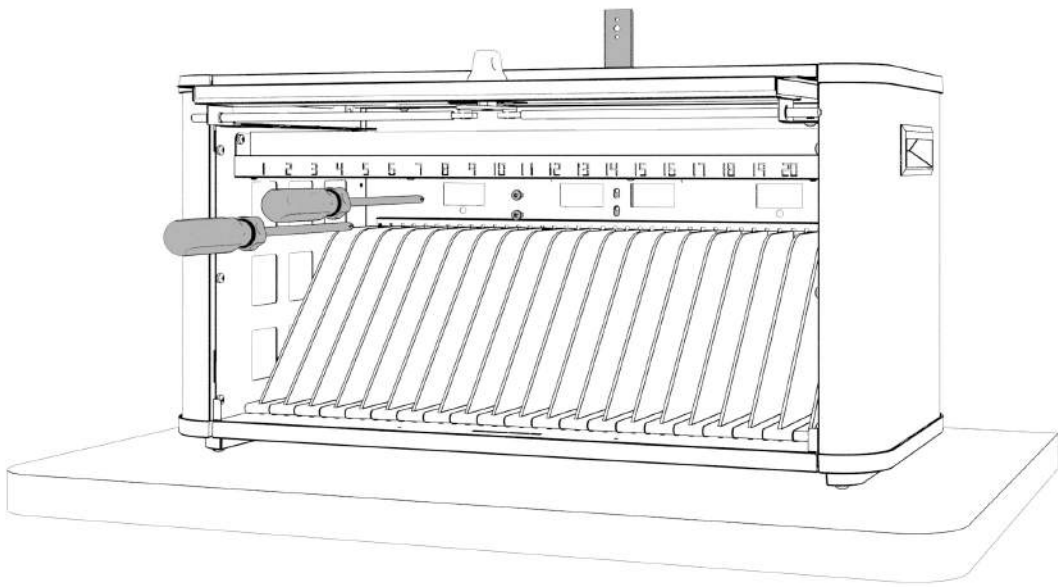

2

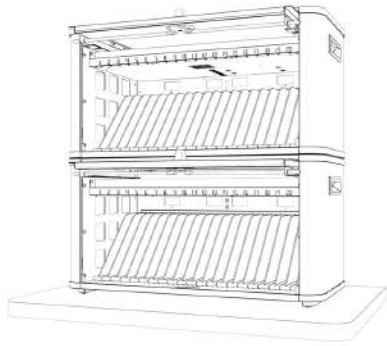

?

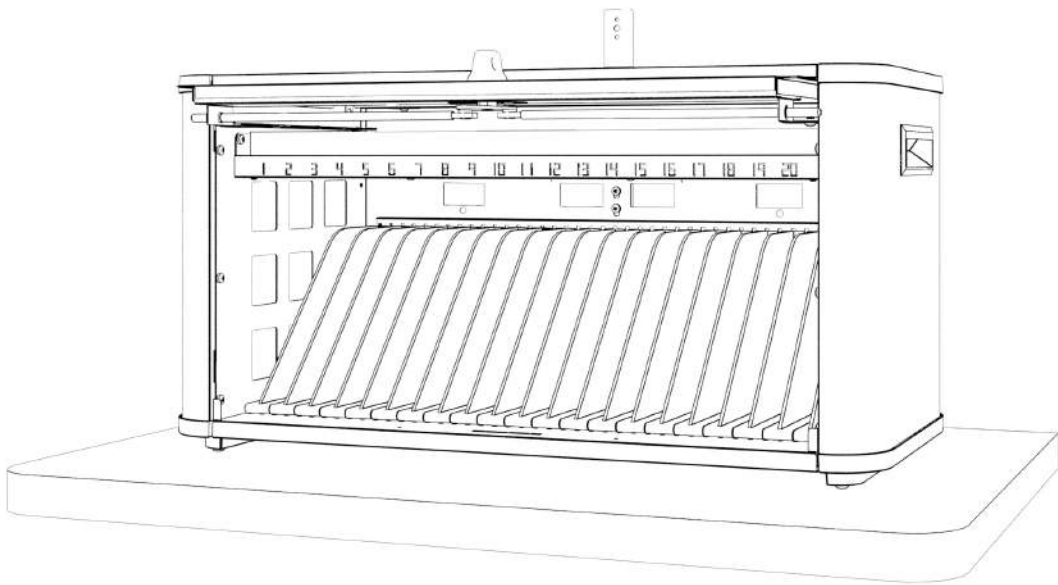

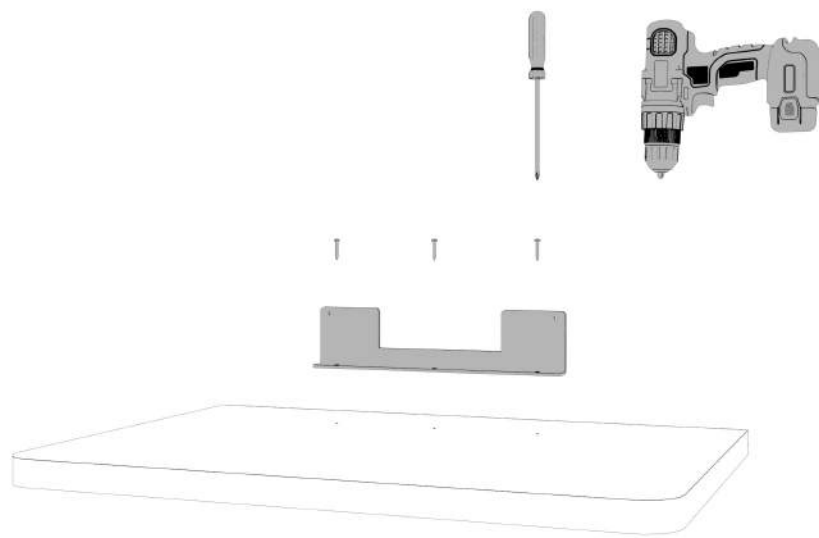

3

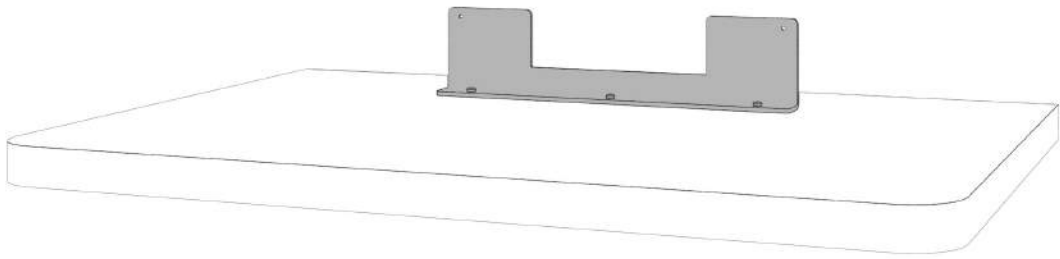

4

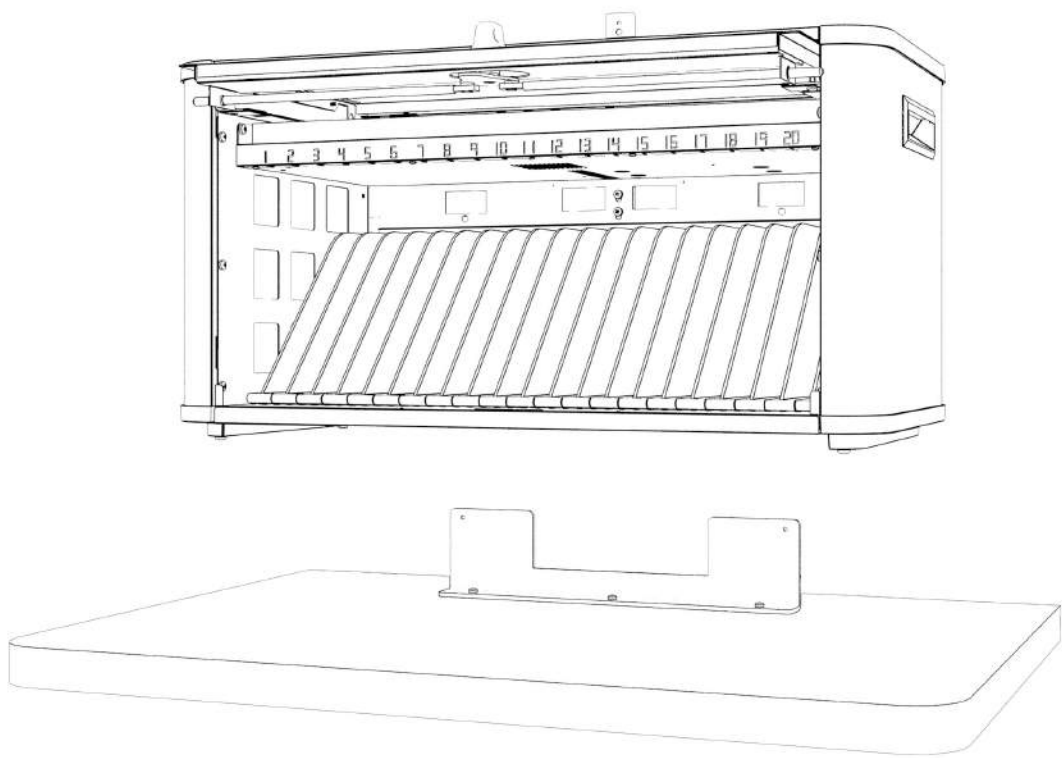

5

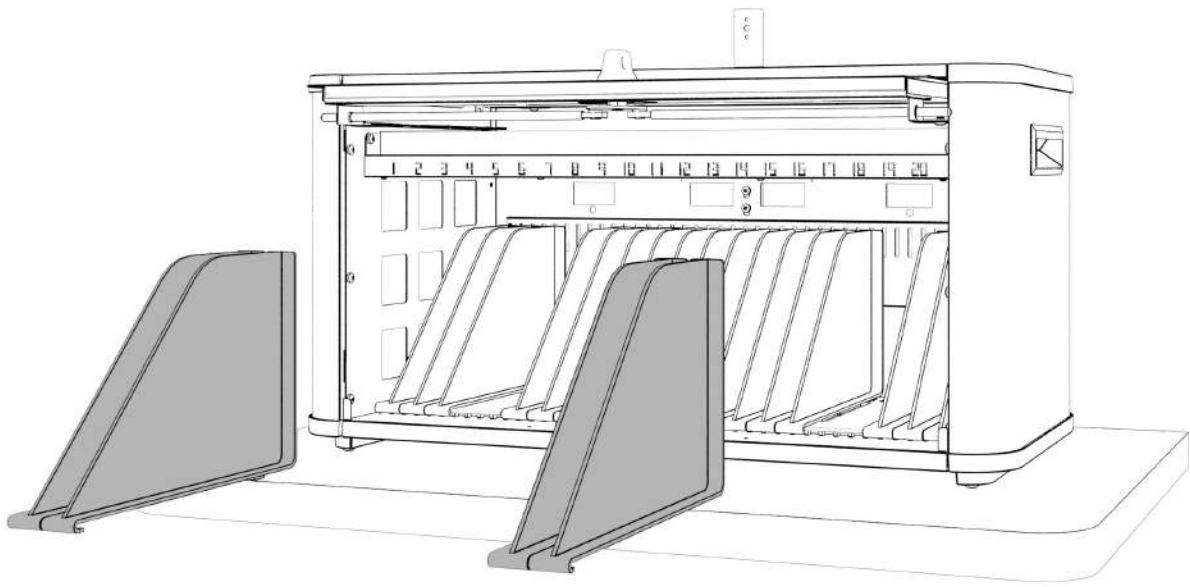

6

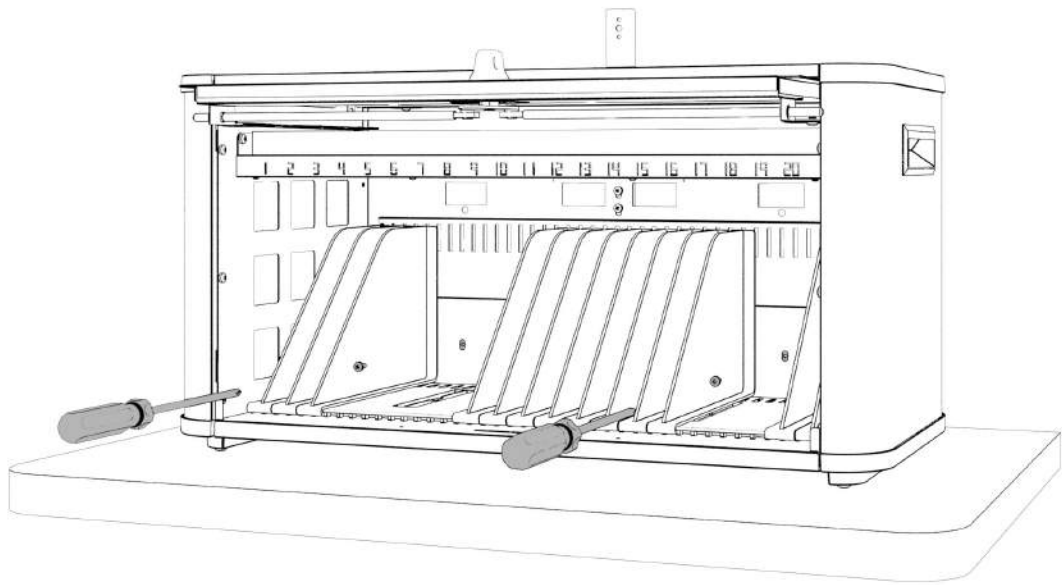

7

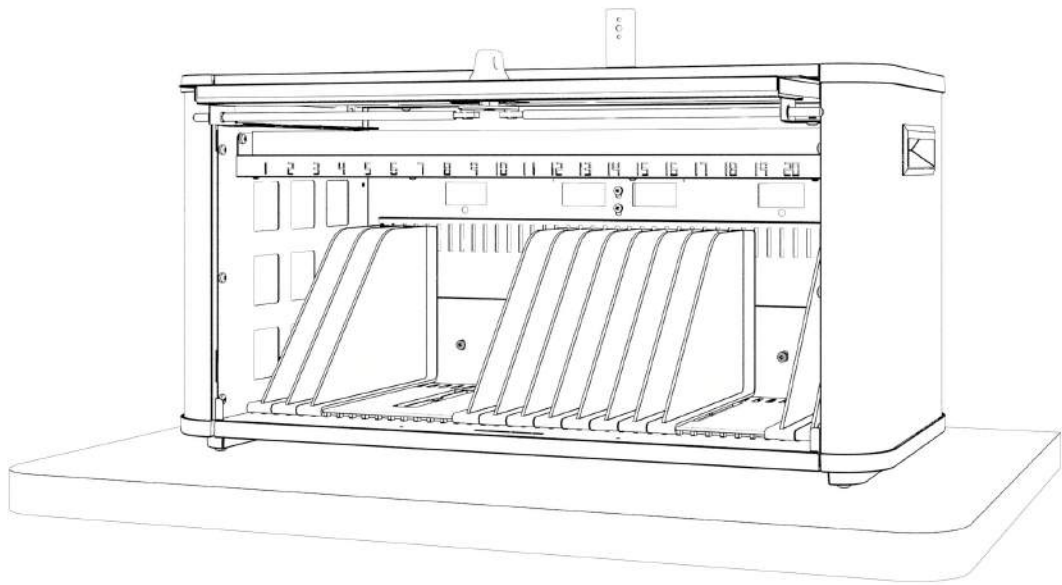

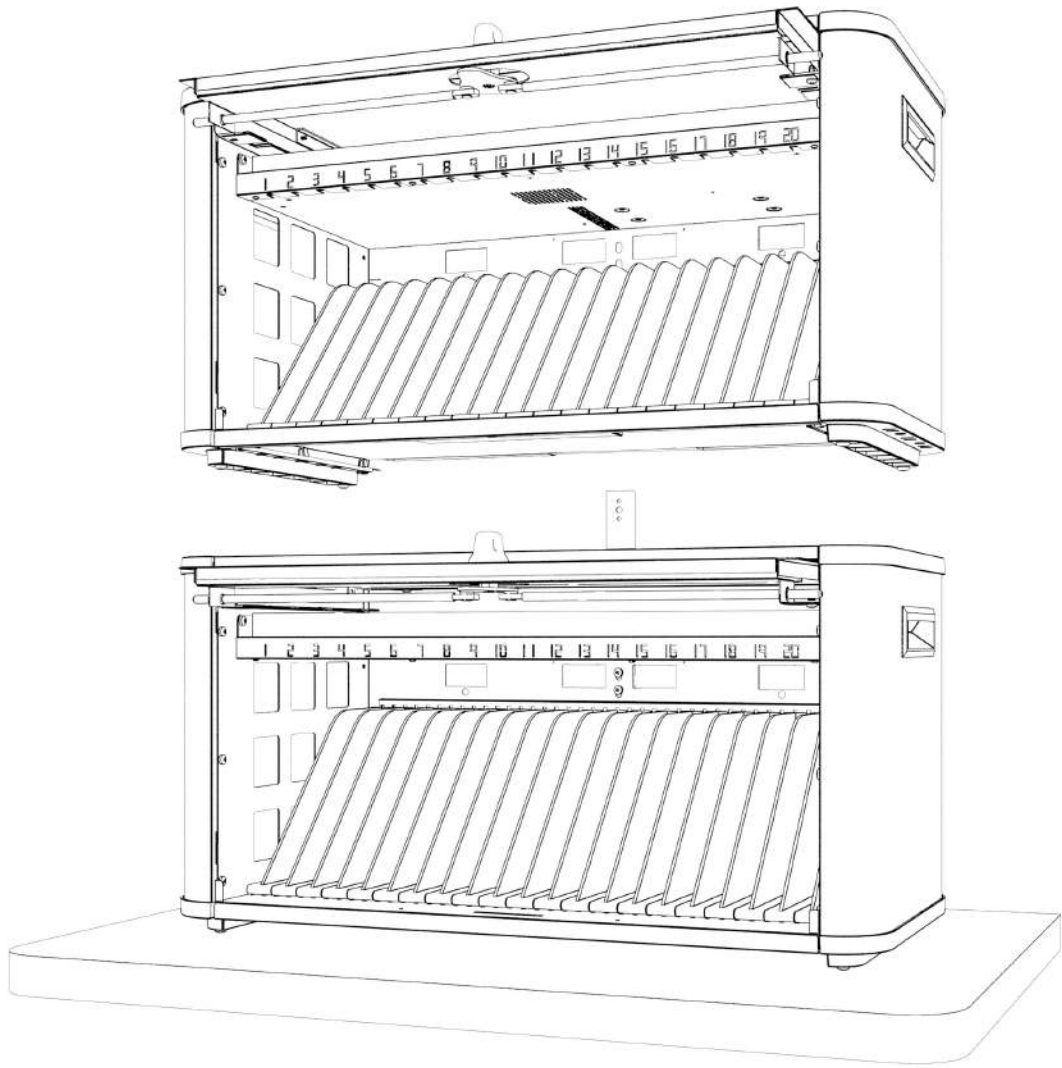

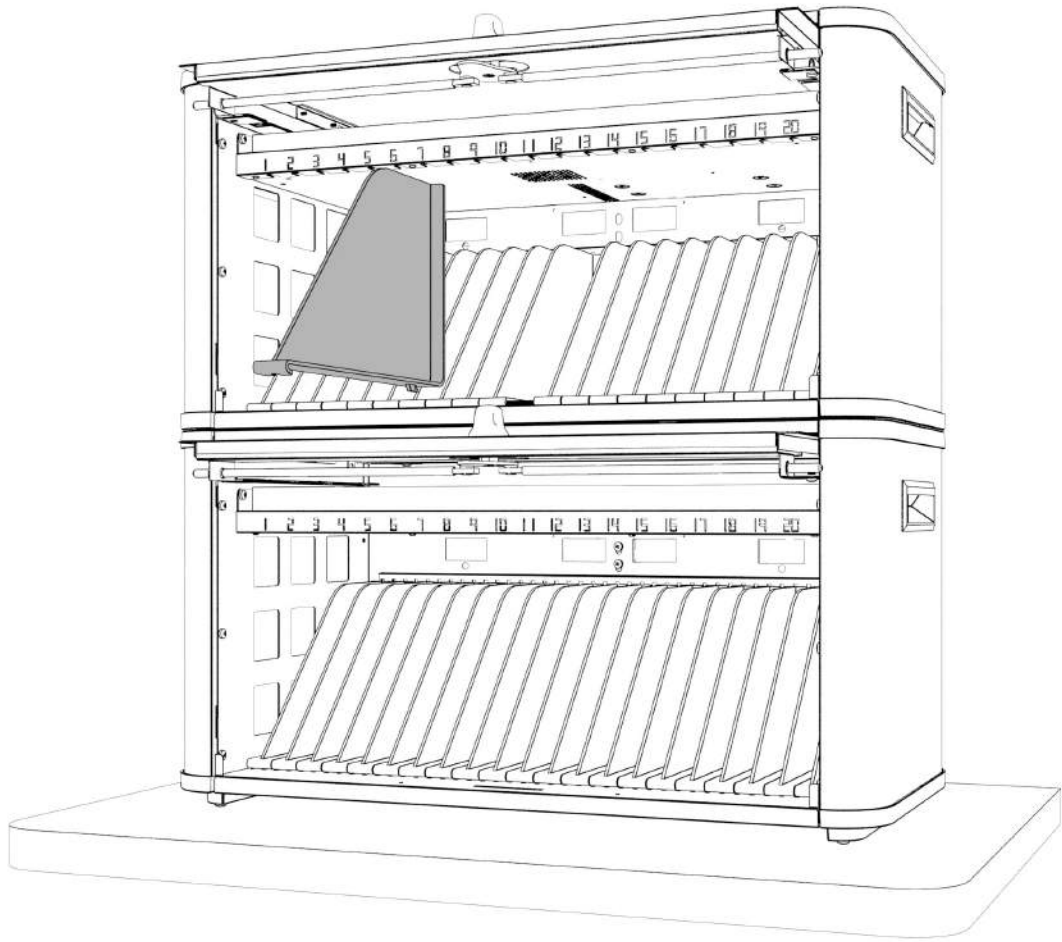

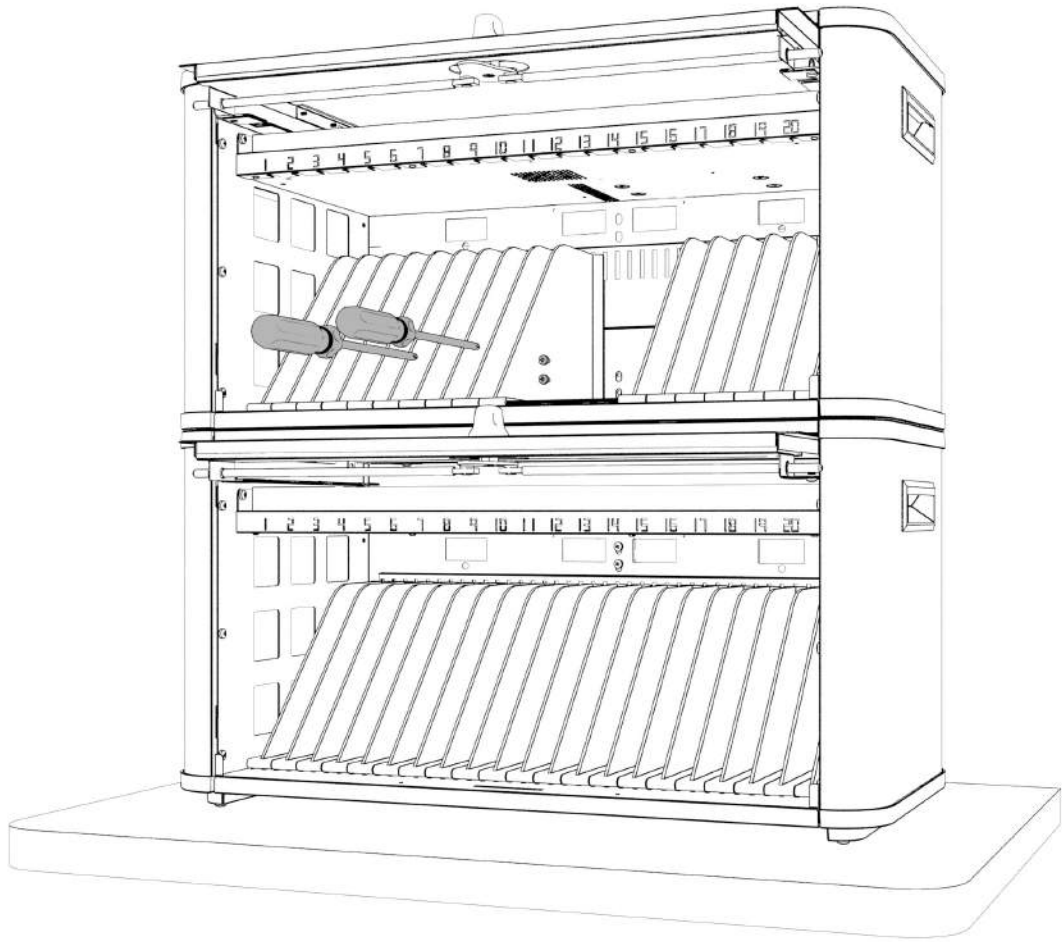

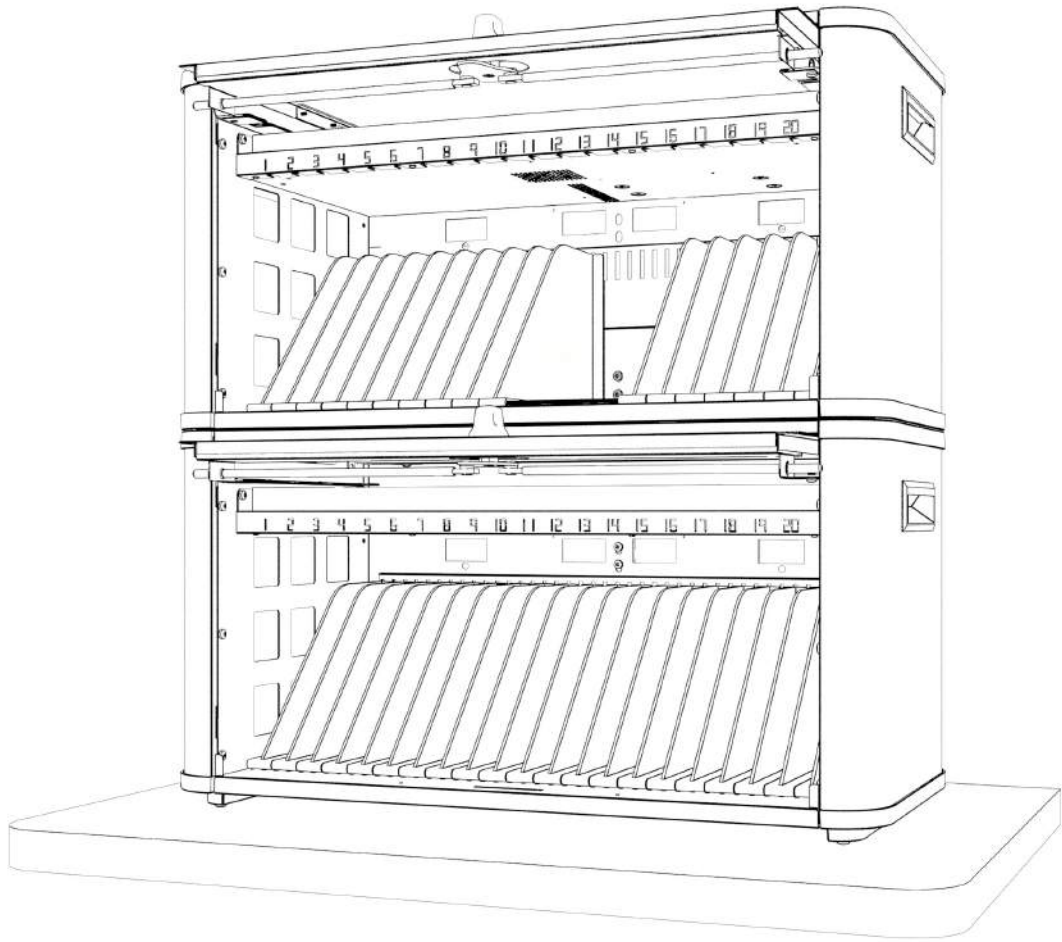

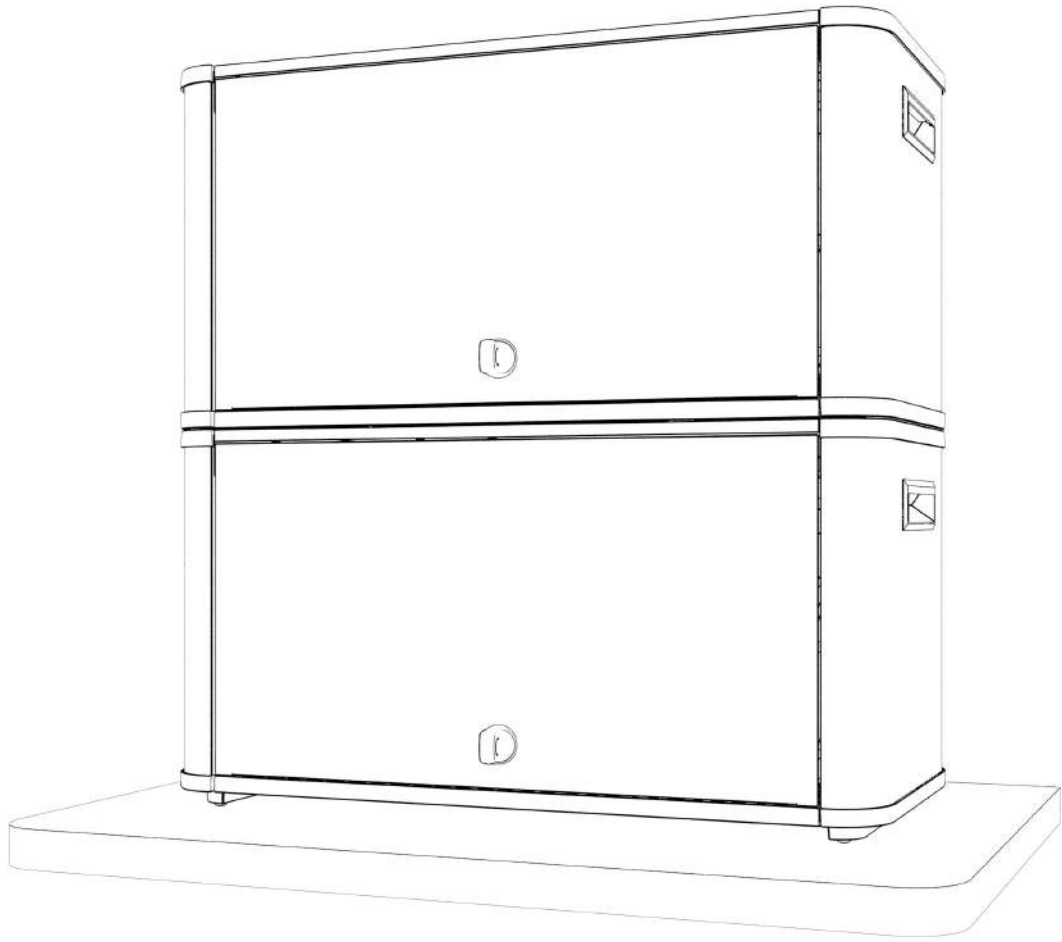

Done!

Wall Mounting

The PowerSync Station 20 can be mounted to a wall, providing added security for your iPad devices, and freeing up valuable desk space.

Mounting to a wall requires:

- PowerSync Station 20 for iPad.
- Wall mounting bracket (included)
- Toggle bolt wall anchors. We have included for or other anchors appropriate for your surface (included). The holes in the Surface Mounting Bracket are 9/32 inch (7mm) diameter.
- Four 1/4"-20 bolts (included)
- #2 phillips screwdriver

To attach the stacking bracket:

1. Drill ½” diameter (13mm) hole. Hold metal channel flat alongside plastic straps and slide channel through hole
2. Hold ends of straps between thumb and forefinger and pull toward you until channel rests flush behind wall. Slide plastic cap along straps with other hand until flange of cap is flush with wall.
3. Snap straps at wall by pushing side to side, snapping off straps level with flange of cap.
4. Repeat for each marked hole.
5. Place wall-mount bracket over flanges, insert bolts, and tighten until flush against mounting bracket.
6. Mount the Surface-Mount Bracket to your wall / surface,

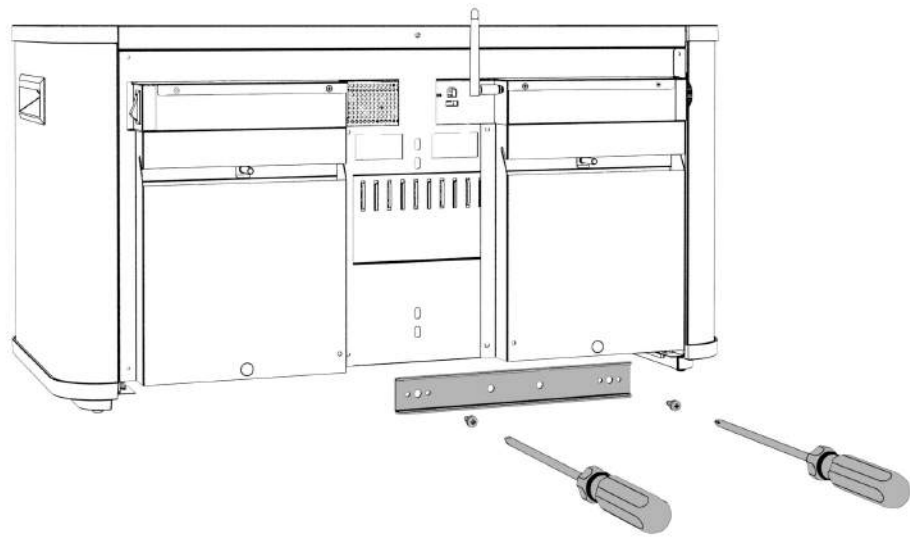

1

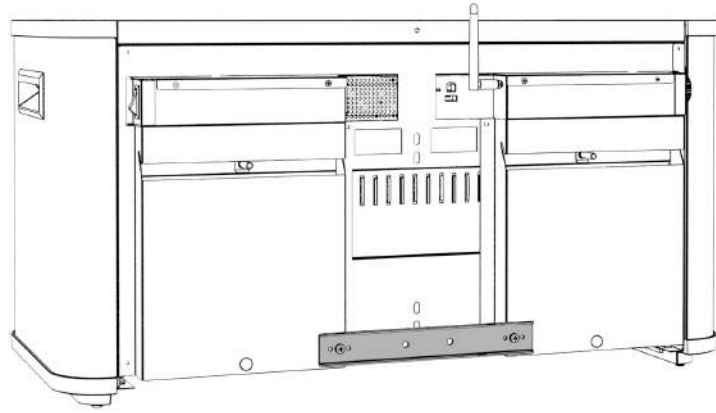

2

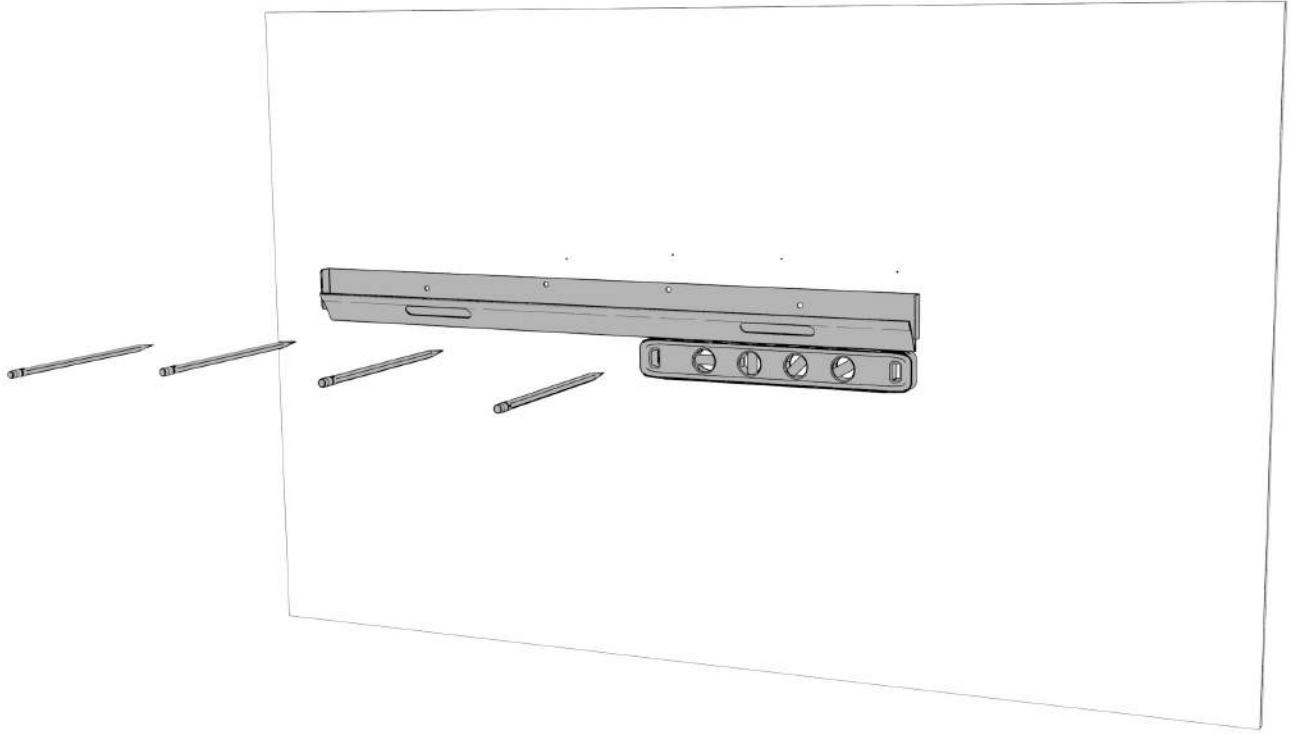

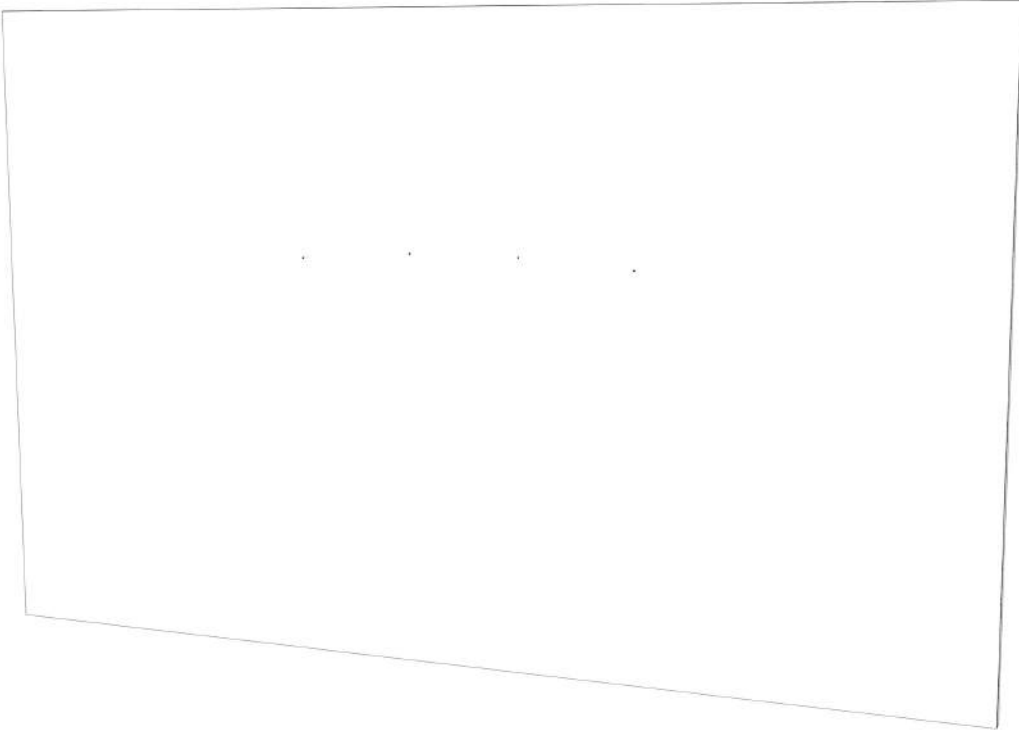

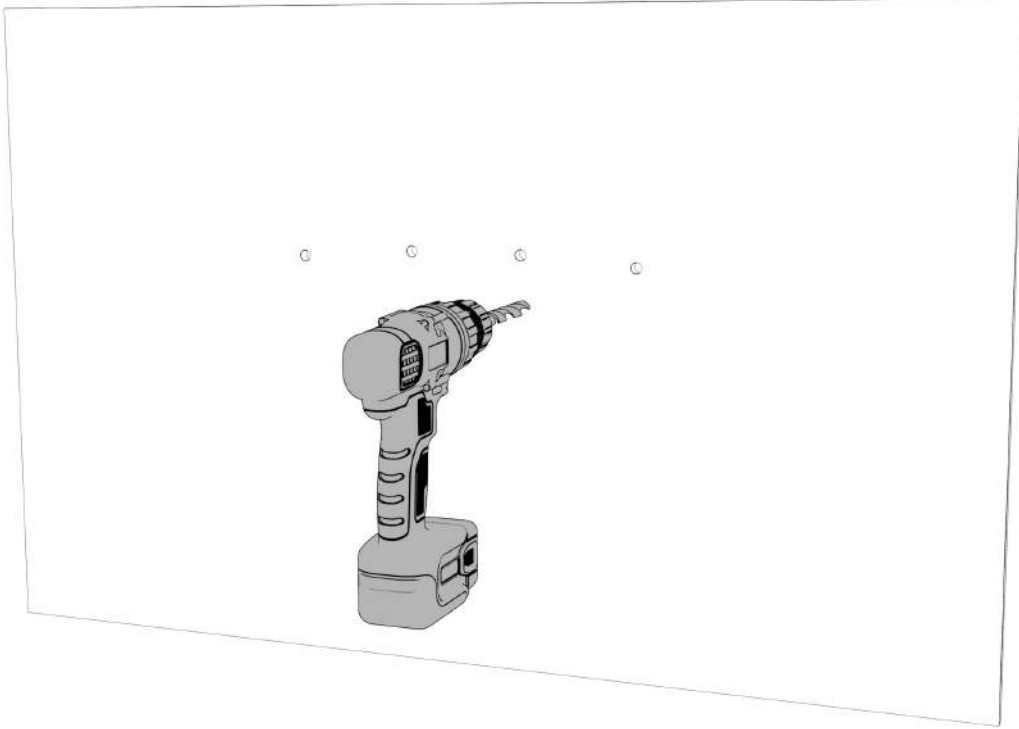

4

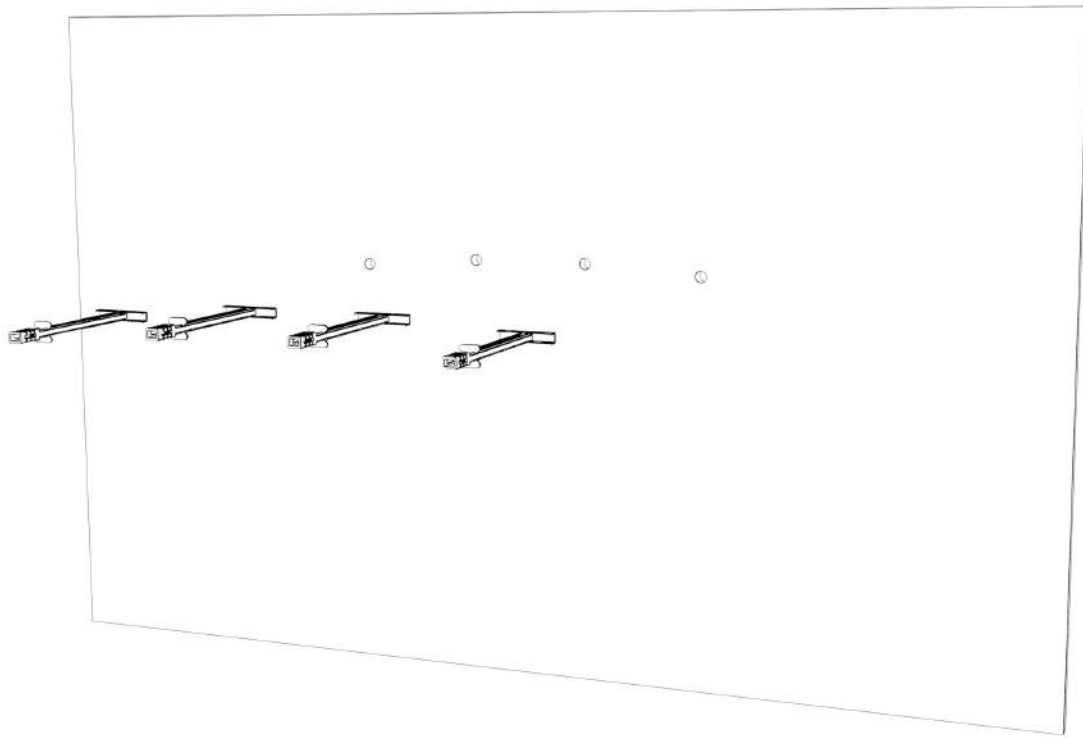

5

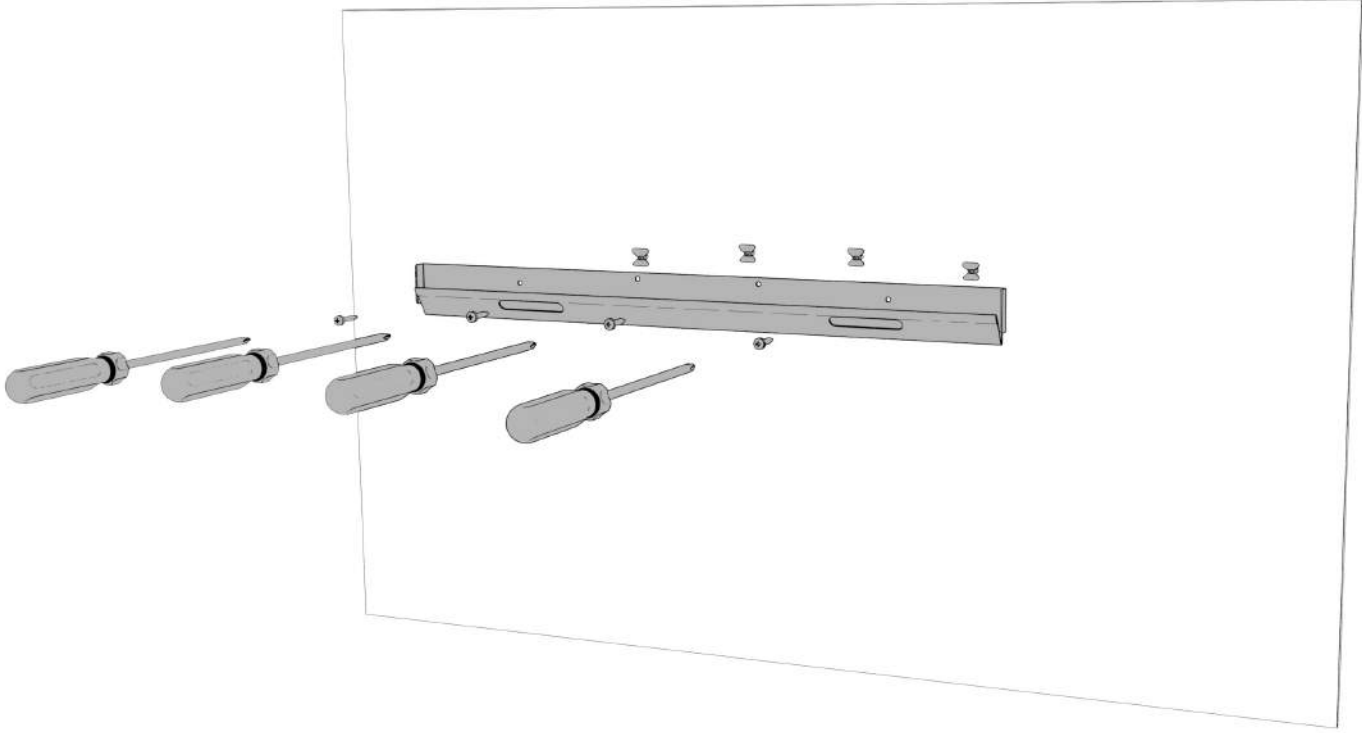

10

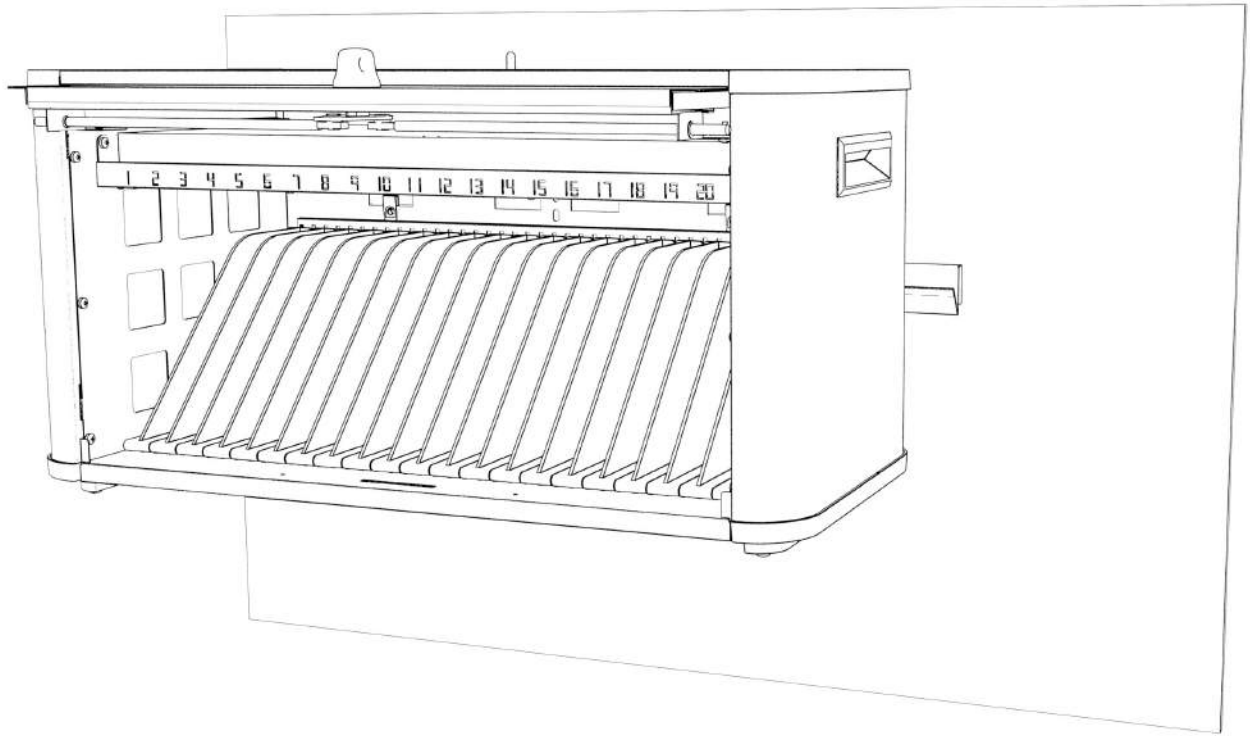

10

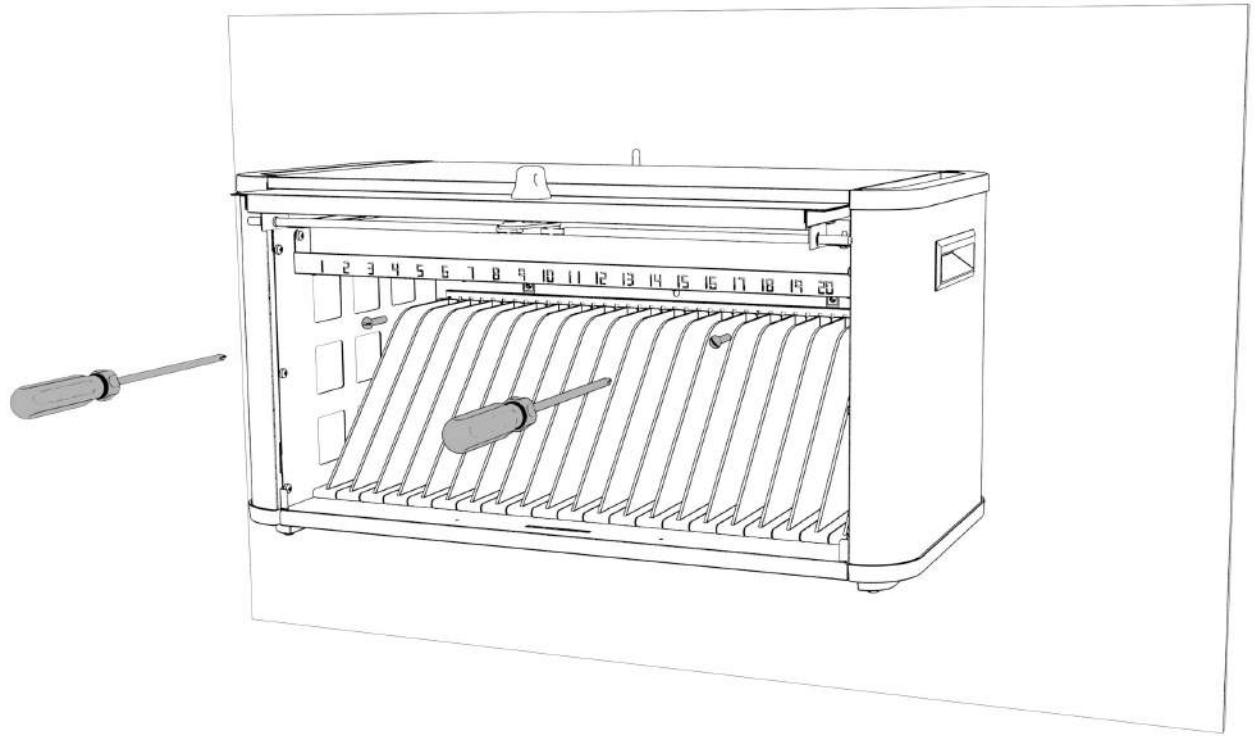

10

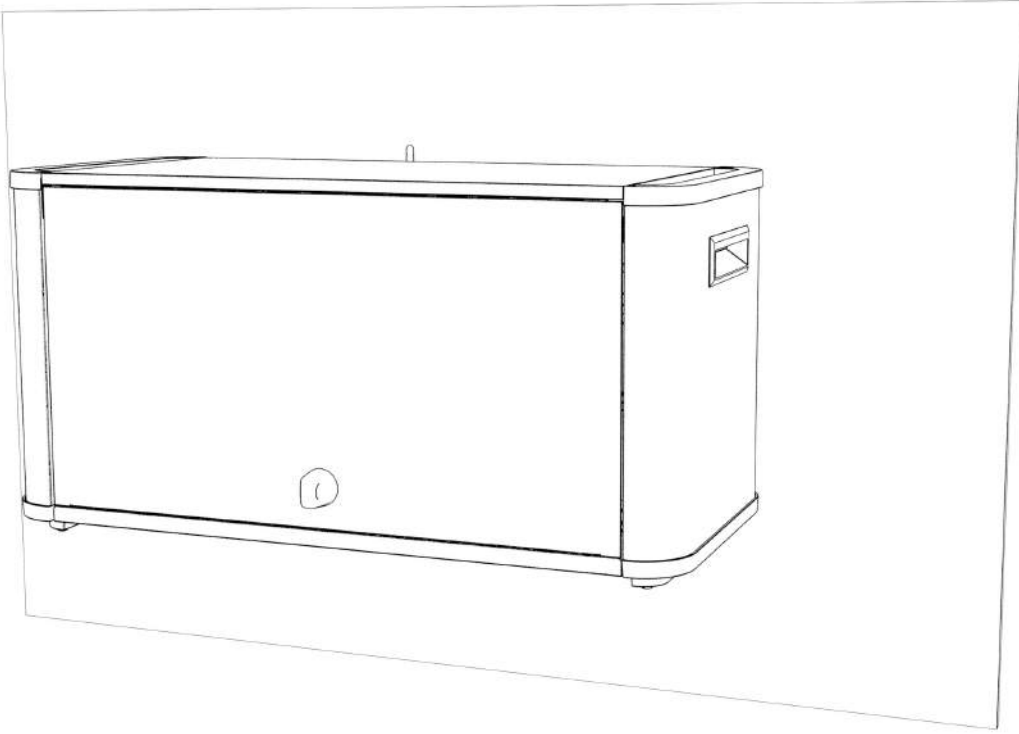

Done!

