

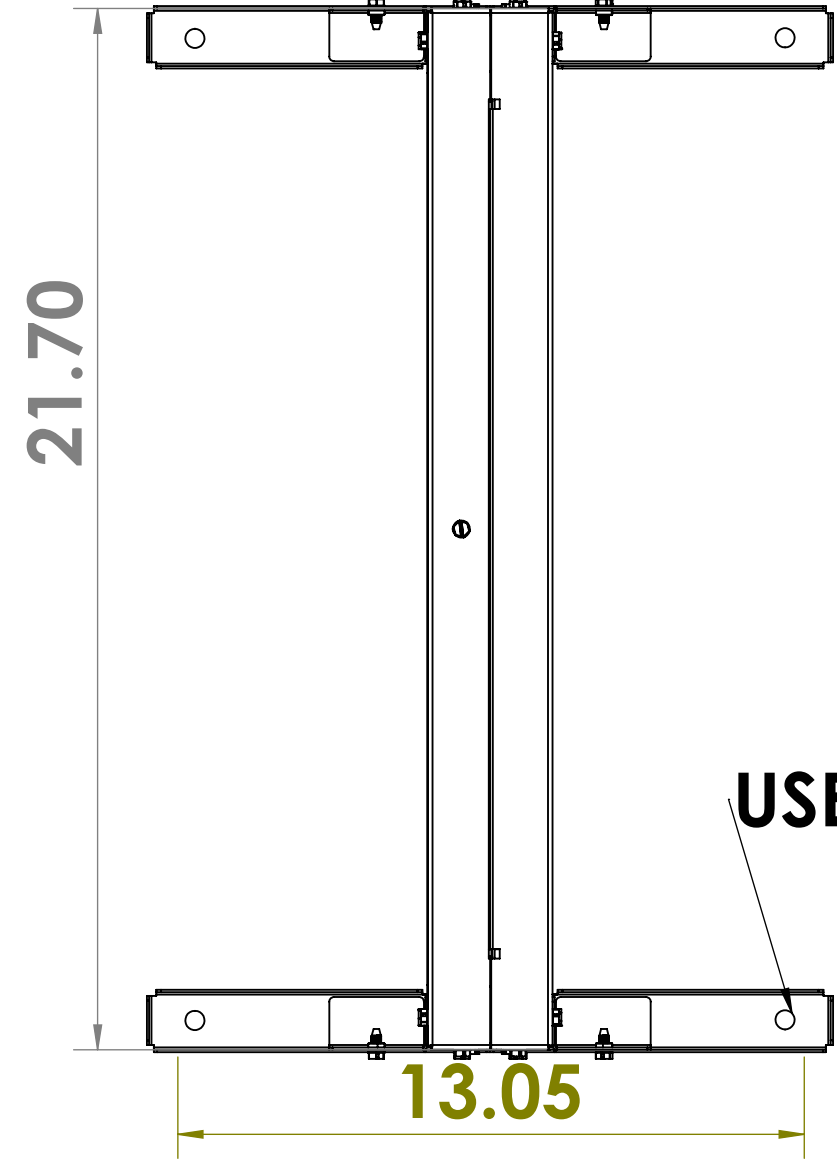

ITEM NO.	PART NUMBER	DESCRIPTION	QTY.
1	V2-PEM-XR2-BA-TA	XR2 TOP AND BOTTOM COVER	2
2	V2-PEM-XR2-BB-TB	XR2 TOP AND BOTTOM COVER	2
3	V2-PEM-SLOT-311	SCREW #10-32 X 1/2 LG.	62
4	V2-PEM-XR2-STR-B	XR2 TOP AND BOTTOM STARTER SEGMENT B	4
5	V2-PEM-XR2-BS	BOTTOM STAND SUPPORT	2
6	V2-PEM-XR2-STR-A	XR2 TOP AND BOTTOM STARTER SEGMENT A	4
7	V2-PEM-XR2-EXT-B	XR2 EXTENSION CENTER SEGMENT B	2
8	V2-PEM-SS-032-2ZI	10-32 PEM NUT	62
9	V2-PEM-XR2-CT19	XR4-CROSS TIE 19"	2
10	V2-PEM-XR4-CB1	XR4 CONNECTING BRACKET	8
11	V2-PEM-XR2-BSBL	BOTTOM STABILIZING BRACKET -LEFT	2
12	V2-PEM-XR2-BSBR	BOTTOM STABILIZING BRACKET -RIGHT	2
13	V2-PEM-XR2-EXT-A	XR2 EXTENSION CENTER SEGMENT A	2



XR2 - TWO POST SEGMENTED RACK

USE FLOOR STUD ANCHOR (MIN DIAMETER OF 0.25" (4 PLACES))

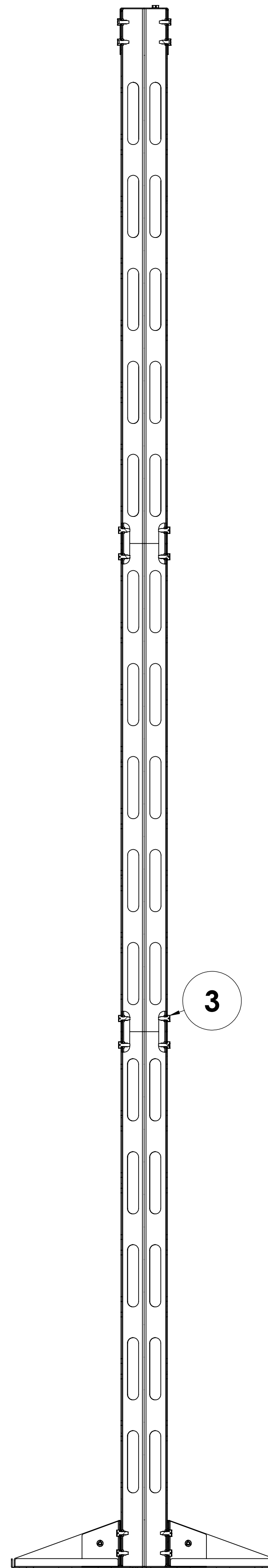
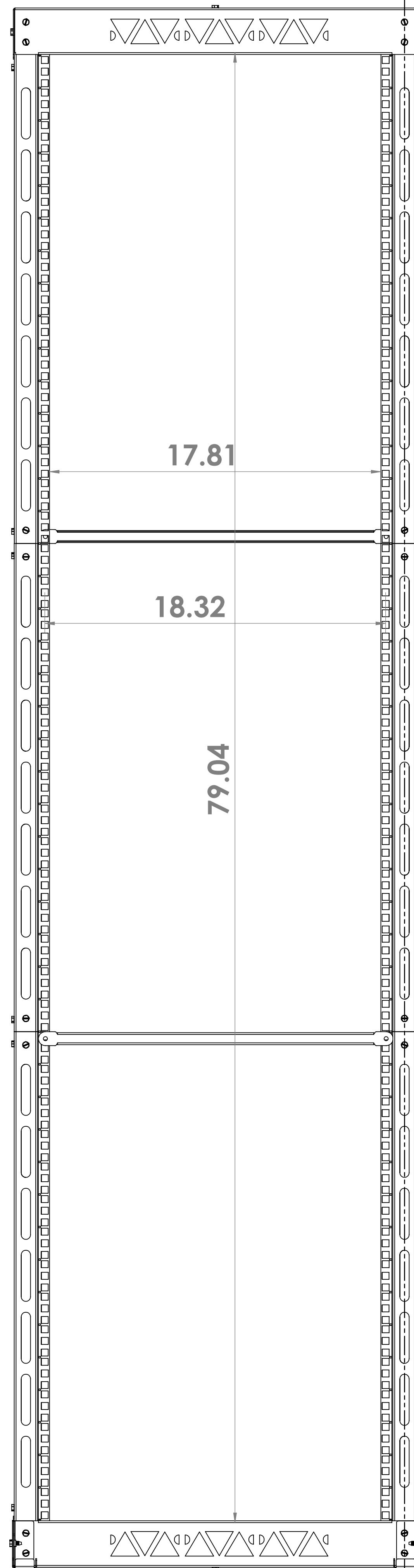
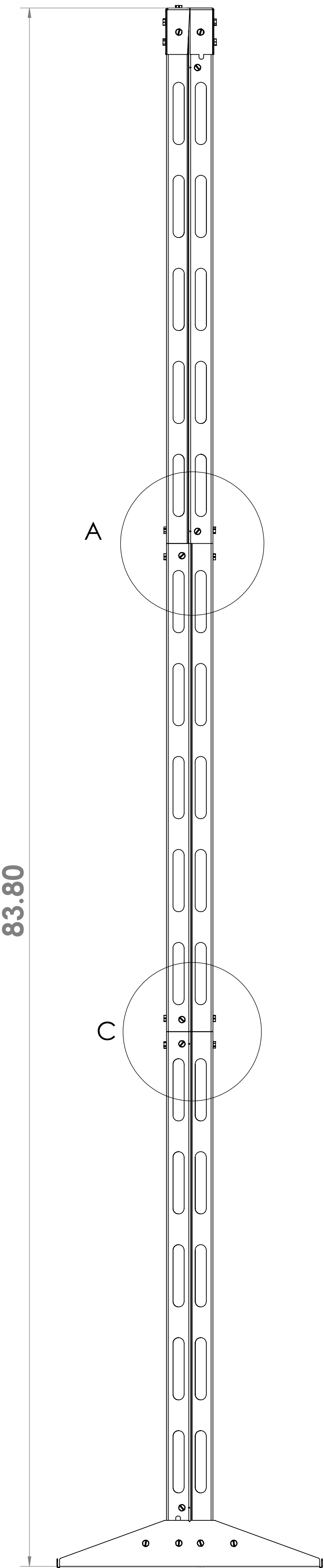

SECTION A-D

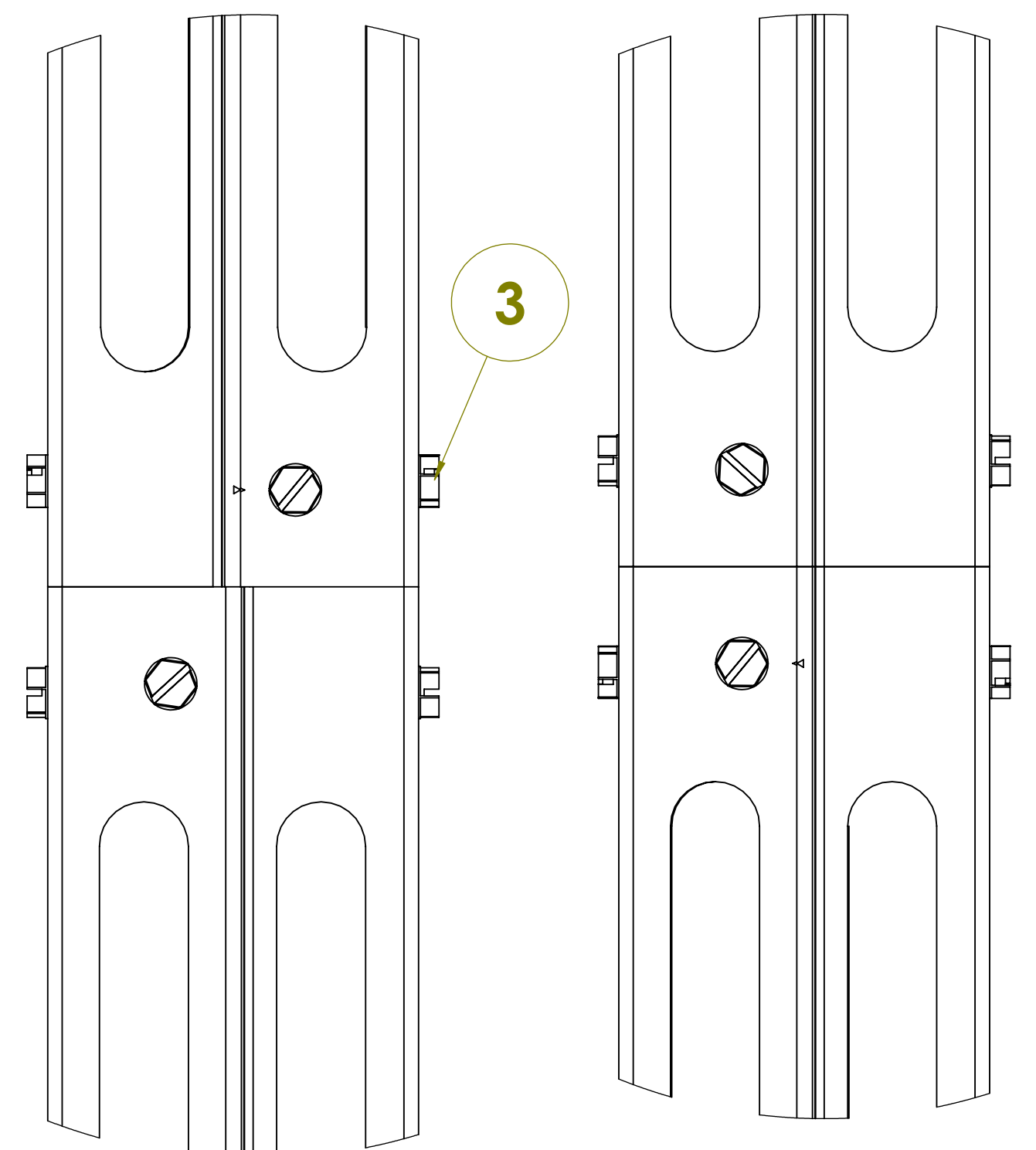
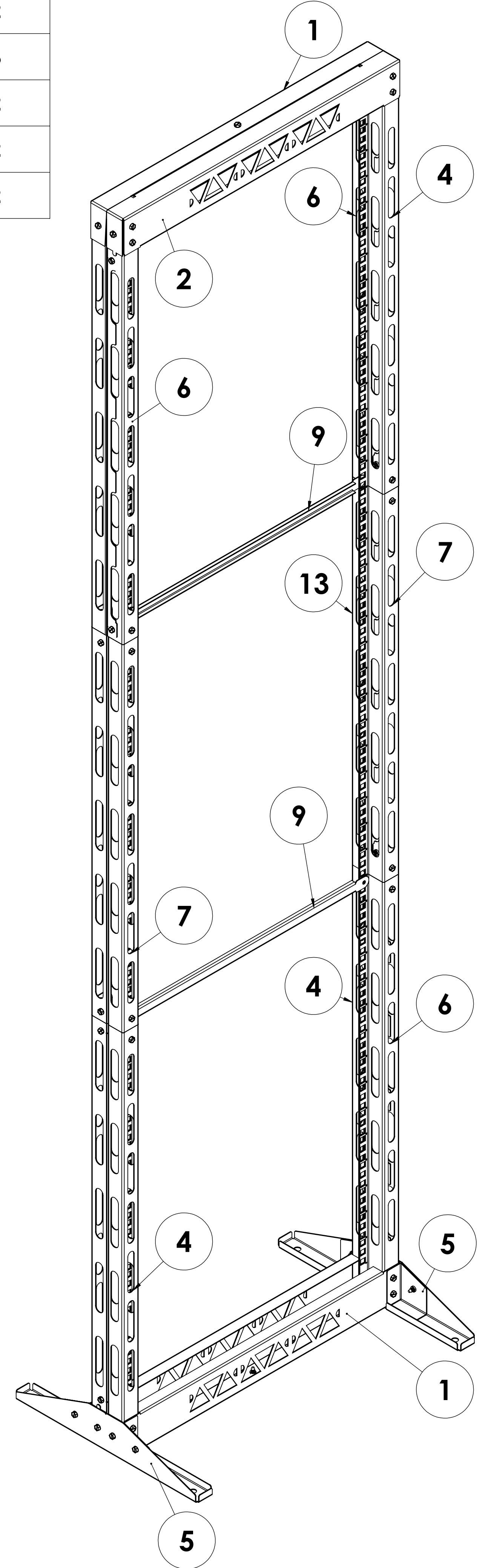

DETAIL A

DETAIL C