

REV.	DATE	DESCRIPTION	BY	C'K'D.
1	8/23/93	ADDED "OPTIONAL SHROUDED" NOTE (DO 58720) SEE REV. REF. PRINT (PCN 1404)	JLM	KH
2	12/23/94	SEE MARK-UP (PCN 2897) PER OTEAM 94-271, 94-288	JWA	JLM

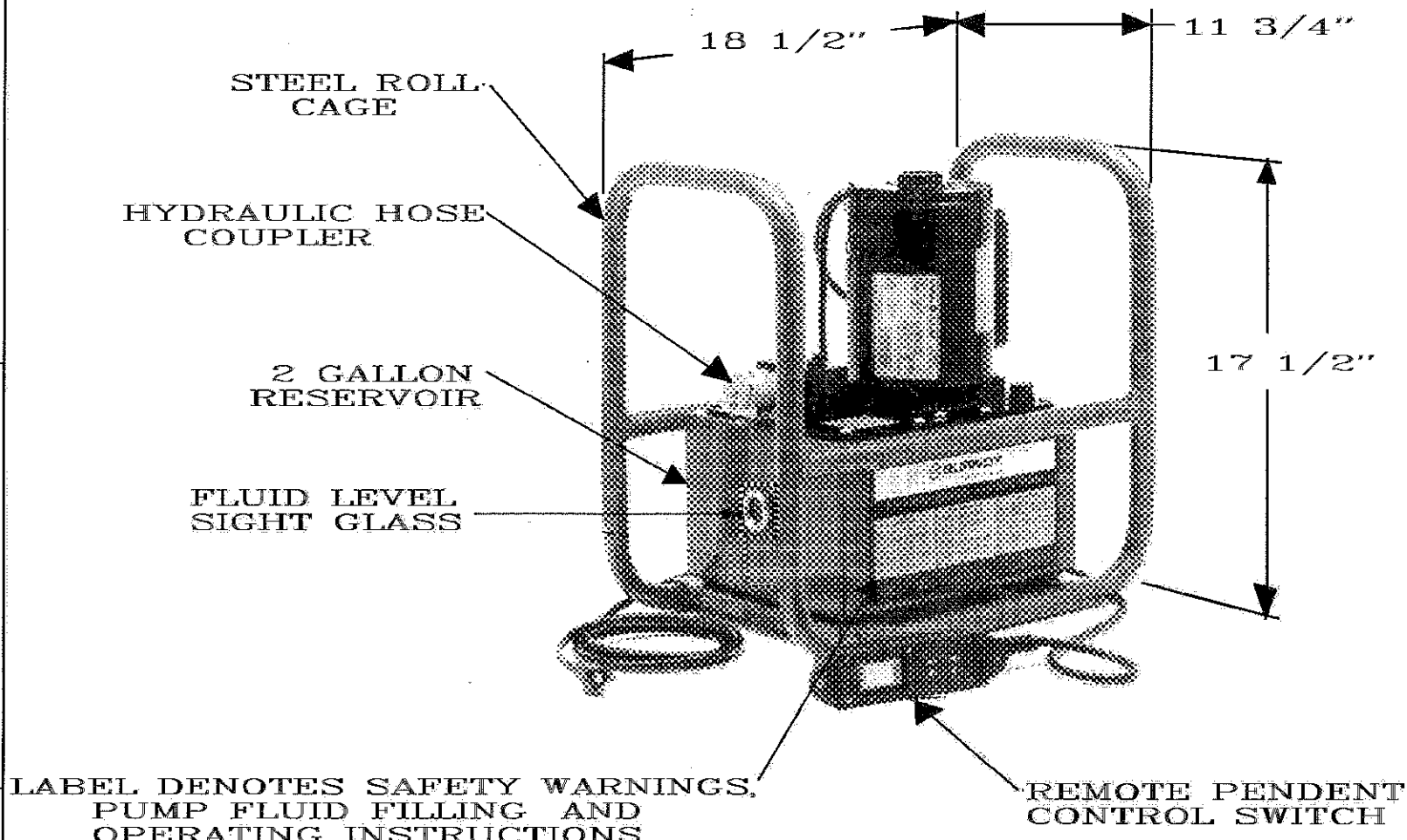

(OPTIONAL SHROUDED FOOT PEDAL CONTROL AVAILABLE. CONTROL FEATURES A 10 FOOT LONG CORD. TO ORDER EP.. SERIES PUMP WITH FOOT PEDAL CONTROL ADD SUFFIX "-FC" TO PUMP CAT. NO. SEE TABLE SHEET 4.

FIGURE 1 (EP..SERIES PUMP SHOWN)

FEATURES:

- HYDRAULIC FLUID: BURNDY ALFLUID® (2 GALLONS) SUPPLIED WITH UNIT. SEE RESERVOIR LABEL FOR PUMP FLUID FILLING INSTRUCTIONS.
- ROLL CAGE: HEAVY DUTY STEEL HELPS PROTECT RESERVOIR AND PUMP FROM DAMAGE. CAGE PROVIDES A STABLE STANCE AND EASES TRANSPORTATION.
- REMOTE PENDENT CONTROL SWITCH: PRESS SWITCH TO START CRIMP CYCLE, RELEASE SWITCH TO STOP CRIMP CYCLE.
- BLOWOFF VALVE: FACTORY PRESET FOR PROPER CRIMP PRESSURE. WHEN LINE PRESSURE IS REACHED AN AUDIABLE "POP" INDICATES PROPER CRIMP PRESSURE WAS ACHIEVED.
- RESERVOIR SIGHT GLASS: PROVIDED FOR FAST EASY INSPECTION OF MINIMUM FLUID LEVEL. (ALWAYS CHECK FLUID LEVEL PRIOR TO OPERATING)

SPECIFICATIONS FOR EP.. PUMP.

- RESERVOIR CAPACITY: 2 GALLONS
- HYDRAULIC FLUID TYPE: BURNDY ALFLUID®
- LENGTH: 18 1/2"
- WIDTH: 11 3/4"
- HEIGHT: 17 1/2"
- DRY WEIGHT: 54 LBS (INCLUDES ROLL CAGE)
- WET WEIGHT: 68 LBS (INCLUDES ROLL CAGE)
- OUTPUT PRESSURE: SEE TABLE ON SHEET 4
- HORSEPOWER: 1/2HP @ 3450 RPM
- VOLTAGE: 115 VOLT AC, 60 CYCLE
220/230 VOLT, 50/60 CYCLE

REV. 111991

EP SERIES ELECTRIC HYDRAULIC PUMPS			
CAT NO: EP, EP--1HP, EP--FC (TABLE)	SCALE: NONE		
DRWNG. JSG 7/9/92	CHECKED, DF 7/22/92		
DSGN APPL. JL 7/27/92	MFG APPL.		
S.A. APPL. AL 8/7/92	PKTS APPL. MB 7/27/92		
CAD FILE: N/A	PH REF: N/A		
PROJECT:			
DRAWING NO.			
SE207894			
SHEET 1 OF 5		REV 2	



REV.	DATE	DESCRIPTION	BY	C'K'D.
1	8/26/93	SEE REV. REF. PRINT (PCN 1404)	JLM	RER
2	12/23/94	SEE MARK-UP (PCN 2087) PER OTRAM 94-271, 94-288	JWA	JLM

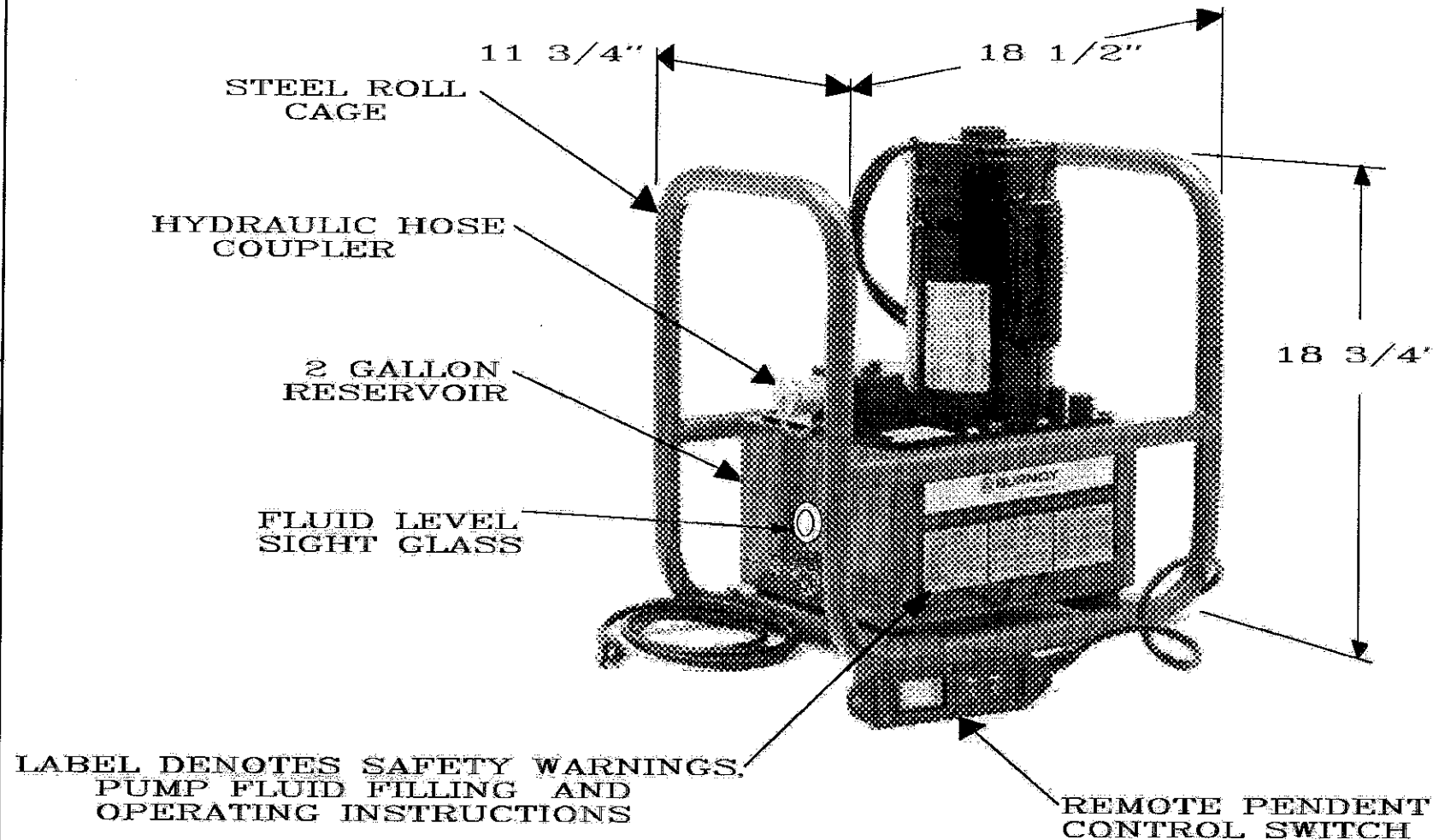

FIGURE 2
EP..1HP SERIES PUMP SHOWN

FEATURES:

- HYDRAULIC FLUID: BURNDY ALFLUID[®] (2 GALLONS) SUPPLIED WITH UNIT. SEE RESERVOIR LABEL FOR PUMP FILLING INSTRUCTIONS.
- ROLL CAGE: HEAVY DUTY STEEL HELPS PROTECT RESERVOIR AND PUMP FROM DAMAGE. CAGE PROVIDES A STABLE STANCE AND EASES TRANSPORTATION.
- REMOTE PENDENT CONTROL SWITCH: PRESS SWITCH TO START CRIMP CYCLE, RELEASE SWITCH TO STOP CRIMP CYCLE.
- BLOWOFF VALVE: FACTORY PRESET FOR PROPER CRIMP PRESSURE. WHEN LINE PRESSURE IS REACHED AN AUDIABLE "POP" INDICATES PROPER CRIMP PRESSURE WAS ACHIEVED.
- RESERVOIR SIGHT GLASS: PROVIDED FOR FAST EASY INSPECTION OF MINIMUM FLUID LEVEL. (ALWAYS CHECK FLUID LEVEL PRIOR TO OPERATION.)

SPECIFICATIONS FOR EP..1HP SERIES PUMPS:

- RESERVOIR CAPACITY: 2 GALLONS
- HYDRAULIC FLUID TYPE: BURNDY ALFLUID[®]
- LENGTH: 18 1/2"
- WIDTH: 11 3/4"
- HEIGHT: 18 3/4"
- DRY WEIGHT: 72 LBS (INCLUDES ROLL CAGE)
- WET WEIGHT: 86 LBS (INCLUDES ROLL CAGE)
- OUTPUT PRESSURE: SEE TABLE ON SHEET 4
- HORSEPOWER: 1HP @ 3450 RPM
- VOLTAGE: 115 VOLT AC, 60 CYCLE
220/230 VOLT, 50/60 CYCLE ◀

REV. 11/93

EP SERIES ELECTRIC HYDRAULIC PUMPS			
DWG. NO. EP..EP--1HP(TABLE)	SCALE	NONE	
DRWN. JSC 7/9/92	CHECKED. DF 7/22/92	BY	
DSGN. APPL. JL 7/27/92	INFO. APPL.	BY	
S.A. APPL. AL 8/7/92	PKTO. APPL. MB 7/27/92	BY	
CAD. FILE: N/A	PR. REF: N/A	BY	
PROJECT		BY	
DRAWING NO.		REV.	
SE207894		2	
SHEET 2 OF 5			

REV.	DATE	DESCRIPTION	BY	C'K'D.
2	12/23/94	SEE MARK-UP (PCN 2097) PER (OTEAM 94-271, 94-298)	JWA	JLM

STEEL ROLL CAGE

HYDRAULIC HOSE COUPLER

2 GALLON RESERVOIR

FLUID LEVEL SIGHT GLASS

LABEL DENOTES SAFETY WARNINGS, PUMP FLUID FILLING AND OPERATING INSTRUCTIONS

FEATURES:

-HYDRAULIC FLUID: BURNDY ALFLUID™ (2 GALLONS) SUPPLIED WITH UNIT. SEE RESERVOIR LABEL FOR PUMP FILLING INSTRUCTIONS.

-ROLL CAGE: HEAVY DUTY STEEL HELPS PROTECT RESERVOIR AND PUMP FROM DAMAGE. CAGE PROVIDES A STABLE STANCE AND EASES TRANSPORTATION.

-PUMP FEATURES REMOTE FOOT SWITCH FOR JOG/ADVANCE/HOLD CONTROL. WHEN FOOT SWITCH IS ACTUATED, CRIMP/CUTTER TOOL RAM WILL ADVANCE. RELEASE SWITCH AT ANY TIME (PUMP WILL HOLD PRESENT PRESSURE). TO FINISH CRIMP/CUTTER CYCLE, ACTUATE FOOT SWITCH. WHEN FACTORY PRESET CRIMP PRESSURE IS REACHED, THE PUMP WILL AUTOMATICALLY STOP. CRIMP /CUTTER TOOL RAM WILL AUTOMATICALLY RETRACT.

-ON/OFF TOGGLE SWITCH LOCATED ON MOTOR ELECTRICAL BOX.

-BLOWOFF VALVE: FACTORY PRESET FOR PROPER CRIMP PRESSURE. WHEN LINE PRESSURE IS REACHED AN AUDIBLE "POP" INDICATES PROPER CRIMP PRESSURE WAS ACHIEVED.

-RESERVOIR SIGHT GLASS: PROVIDED FOR FAST EASY INSPECTION OF MINIMUM FLUID LEVEL. (ALWAYS CHECK FLUID LEVEL PRIOR TO OPERATION.)

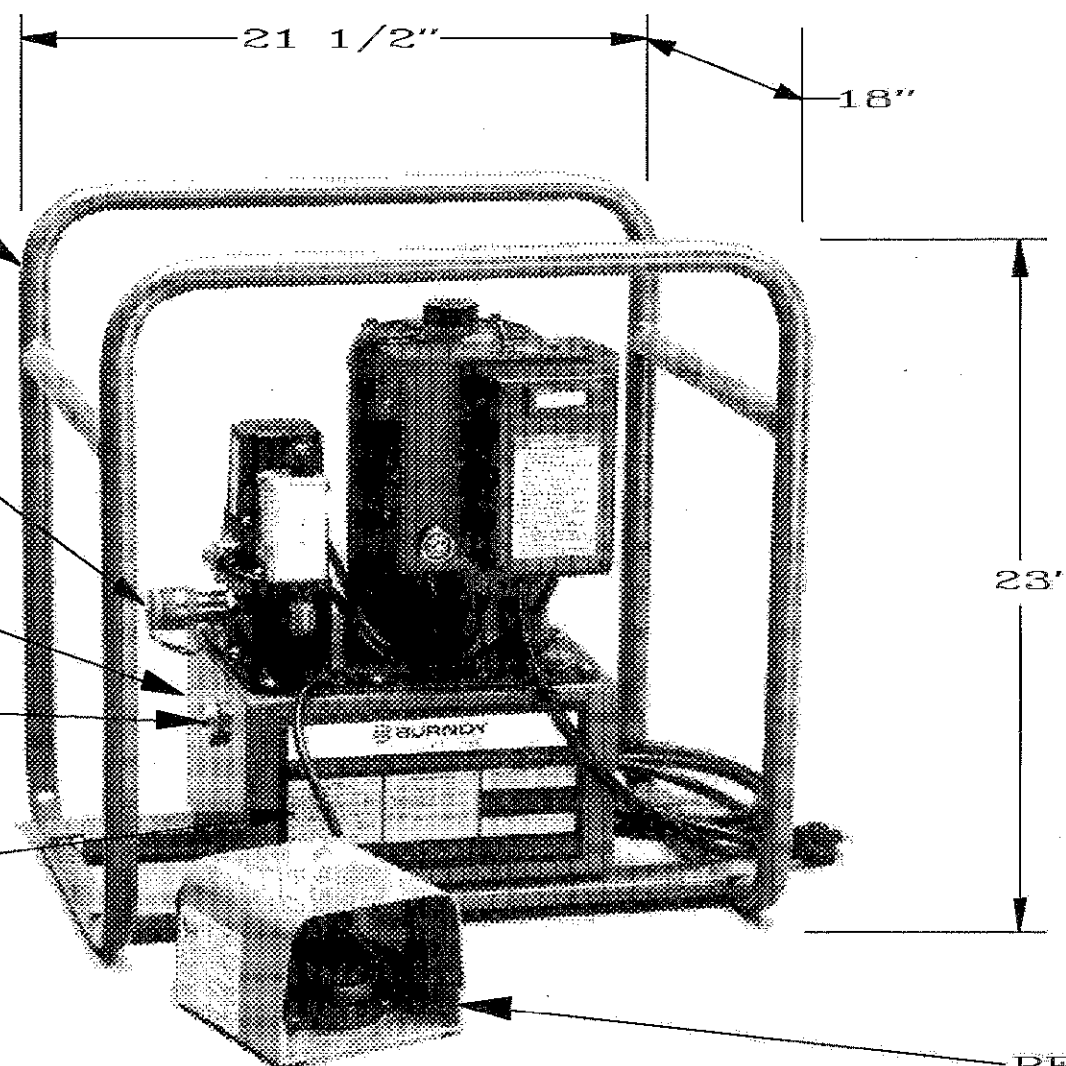

REMOTE FOOT CONTROL SWITCH WITH FOOT GUARD

FIGURE 3
EP..15HPFC SERIES PUMP SHOWN

SPECIFICATIONS FOR EP..15HPFC SERIES PUMPS:

- RESERVOIR CAPACITY: 2 GALLONS
- HYDRAULIC FLUID TYPE: BURNDY ALFLUID™
- LENGTH: 21 1/2"
- WIDTH: 18"
- HEIGHT: 23"
- DRY WEIGHT: 94 LBS (INCLUDES ROLL CAGE)
- WET WEIGHT: 110 LBS (INCLUDES ROLL CAGE)
- OUTPUT PRESSURE: SEE TABLE ON SHEET 5
- HORSEPOWER: 1 1/2 HP @ 3450 RPM
- VOLTAGE: 115 VOLT AC. 60 CYCLE

EP SERIES ELECTRIC HYDRAULIC PUMPS	
CAT NO: EP, EP--1HP, EP--FC (TABLE)	SCALE: N/A
DRAWN: JSG	CHECKED: OF 7/22/92
DESIGN APPVL: JL 7/27/92	MFG APPVL: N/A
S.A. APPVL: AL 8/7/92	METS APPVL: HG 7/27/92
CAD FILE: N/A	PH REF: N/A
PROJECT:	
DRAWING NO. SE207894	
SHEET 3 OF 5	
REV. 2	

REV. 111991

REV.	DATE	DESCRIPTION	BY	C.K'D.
0	12/23/94	THIS INFO. WAS ON SHEET 3 OF 3. SEE MARK-UP (PCN 2007) PER (OTRAM 94-271, 94-290)	JWA	JLM

EP SERIES 1/2 HORSEPOWER (FIGURE 1, SHEET 1)

CATALOG NUMBER	DESCRIPTION	OPERATING OUTPUT PRESSURE (POUNDS/SQUARE INCH)
EP10	ELECTRIC HYDRAULIC PUMP WITH STEEL ROLL CAGE. REMOTE PENDENT CONTROL SWITCH AND 1/2HP 115 VOLT, 60HZ MOTOR	10,000 PSI
EP8	ELECTRIC HYDRAULIC PUMP WITH STEEL ROLL CAGE. REMOTE PENDENT CONTROL SWITCH AND 1/2HP 115 VOLT, 60HZ MOTOR	8,800 PSI
EP6	ELECTRIC HYDRAULIC PUMP WITH STEEL ROLL CAGE. REMOTE PENDENT CONTROL SWITCH AND 1/2HP 115 VOLT, 60HZ MOTOR	6,000 PSI
EP10-2	ELECTRIC HYDRAULIC PUMP WITH STEEL ROLL CAGE. REMOTE PENDENT CONTROL SWITCH AND 1/2HP 220/230 VOLT, 50/60HZ MOTOR	10,000 PSI
EP8-2	ELECTRIC HYDRAULIC PUMP WITH STEEL ROLL CAGE. REMOTE PENDENT CONTROL SWITCH AND 1/2HP 220/230 VOLT, 50/60HZ MOTOR	8,800 PSI
EP6-2	ELECTRIC HYDRAULIC PUMP WITH STEEL ROLL CAGE. REMOTE PENDENT CONTROL SWITCH AND 1/2HP 220/230 VOLT, 50/60HZ MOTOR	6,000 PSI

EP.1HP SERIES 1 HORSEPOWER (FIGURE 2, SHEET 2)

CATALOG NUMBER	DESCRIPTION	OPERATING OUTPUT PRESSURE (POUNDS/SQUARE INCH)
EP10-1HP	ELECTRIC HYDRAULIC PUMP WITH STEEL ROLL CAGE. REMOTE PENDENT CONTROL SWITCH AND 1HP 115 VOLT, 60HZ MOTOR	10,000 PSI
EP8-1HP	ELECTRIC HYDRAULIC PUMP WITH STEEL ROLL CAGE. REMOTE PENDENT CONTROL SWITCH AND 1HP 115 VOLT, 60HZ MOTOR	8,800 PSI
EP6-1HP	ELECTRIC HYDRAULIC PUMP WITH STEEL ROLL CAGE. REMOTE PENDENT CONTROL SWITCH AND 1HP 115 VOLT, 60HZ MOTOR	6,000 PSI
EP10-1HP-2	ELECTRIC HYDRAULIC PUMP WITH STEEL ROLL CAGE. REMOTE PENDENT CONTROL SWITCH AND 1HP 220/230 VOLT, 50/60 HZ MOTOR	10,000 PSI
EP8-1HP-2	ELECTRIC HYDRAULIC PUMP WITH STEEL ROLL CAGE. REMOTE PENDENT CONTROL SWITCH AND 1HP 220/230 VOLT, 50/60 HZ MOTOR	8,800 PSI
EP6-1HP-2	ELECTRIC HYDRAULIC PUMP WITH STEEL ROLL CAGE. REMOTE PENDENT CONTROL SWITCH AND 1HP 220/230 VOLT, 50/60 HZ MOTOR	6,000 PSI

NOTES:

- 1 USES 220/230 VOLTS, 50/60 CYCLE.
- 2 AVAILABLE WITH 10 FOOT LONG FOOT PEDAL CONTROL. TO ORDER ADD SUFFIX "-FC" TO CAT. NO. FOR EX: EP10-FC.

EP--SERIES ELECTRIC HYDRAULIC PUMP			
CAT NO: EP, EP--1HP, EP--FC (TABLE)	SCALE	NONE	
DRWN: J AYER 12/23/94	CHECKED: J MICHAUD 12/27/94		
DSGN: APPVL: JLM 11/8/94	WFO: APPVL: N/A		
S.A. APPVL: DV 12/22/94	NETS: APPVL: MEB 12/27/94		
END FILE: N/A	PH REF: N/A		
			
PROJECT		DRAWING NO.	REV
		SE207894	0
		SHEET 4 OF 5	

REV. 111991

DRAWING NO.
SE207894

4

3

2

1

REV.	DATE	DESCRIPTION	BY	C.K'D.
0	12/22/94	SHEET ADDED PER 0901 2007	JWA	JLM

D

D

C

C

B

B

A

A

EP..15HPFC SERIES 1 1/2 HORSEPOWER (FIGURE 3, SHEET 3)		
CATALOG NUMBER	DESCRIPTION	OPERATING OUTPUT PRESSURE (POUNDS/SQUARE INCH)
EP1015HPFC	ELECTRIC HYDRAULIC PUMP WITH STEEL ROLL CAGE. REMOTE FOOT PEDAL CONTROL SWITCH AND 1 1/2 HP 115 VOLT, 60HZ MOTOR	10,000 PSI
EP815HPFC	ELECTRIC HYDRAULIC PUMP WITH STEEL ROLL CAGE. REMOTE FOOT PEDAL CONTROL SWITCH AND 1 1/2 HP 115 VOLT, 60HZ MOTOR	8,800 PSI
EP615HPFC	ELECTRIC HYDRAULIC PUMP WITH STEEL ROLL CAGE. REMOTE FOOT PEDAL CONTROL SWITCH AND 1 1/2 HP 115 VOLT, 60HZ MOTOR	6,000 PSI

EP SERIES ELECTRIC HYDRAULIC PUMPS			
CAT NO.	EP---HPFC	SCALE	N/A
DRAWN	J AYER	12/23/94	CHECKED: J RICHARD 12/27/94
DSGN APPL.	J LEFAVOUR 11/8/94	PRG APPL.	N/A
S.A. APPL.	D VARIO 12/22/94	PKTD APPL.	M BLAKE 12/27/94
CAD FILE	N/A	PH. REF.	N/A
		MDL. REF.	N/A
PROJECT		DRAWING NO.	REV
		SE207894	0
		SHEET 5 of 5	

REV. 111991

4

3

2

1