

PORTABLE GASOLINE HYDRAULIC PUMP

CATALOG NUMBER	DESCRIPTION	OUTPUT PRESSURE (PSI)
GP10	GAS HYDRAULIC PUMP	10,000
GP8	GAS HYDRAULIC PUMP	8,800
GP6	GAS HYDRAULIC PUMP	6,000

REV	DATE	DESCRIPTION	ECO	BY	CHK.
A	07/10/2014	DRAWING RELEASED	36920	GN	MB

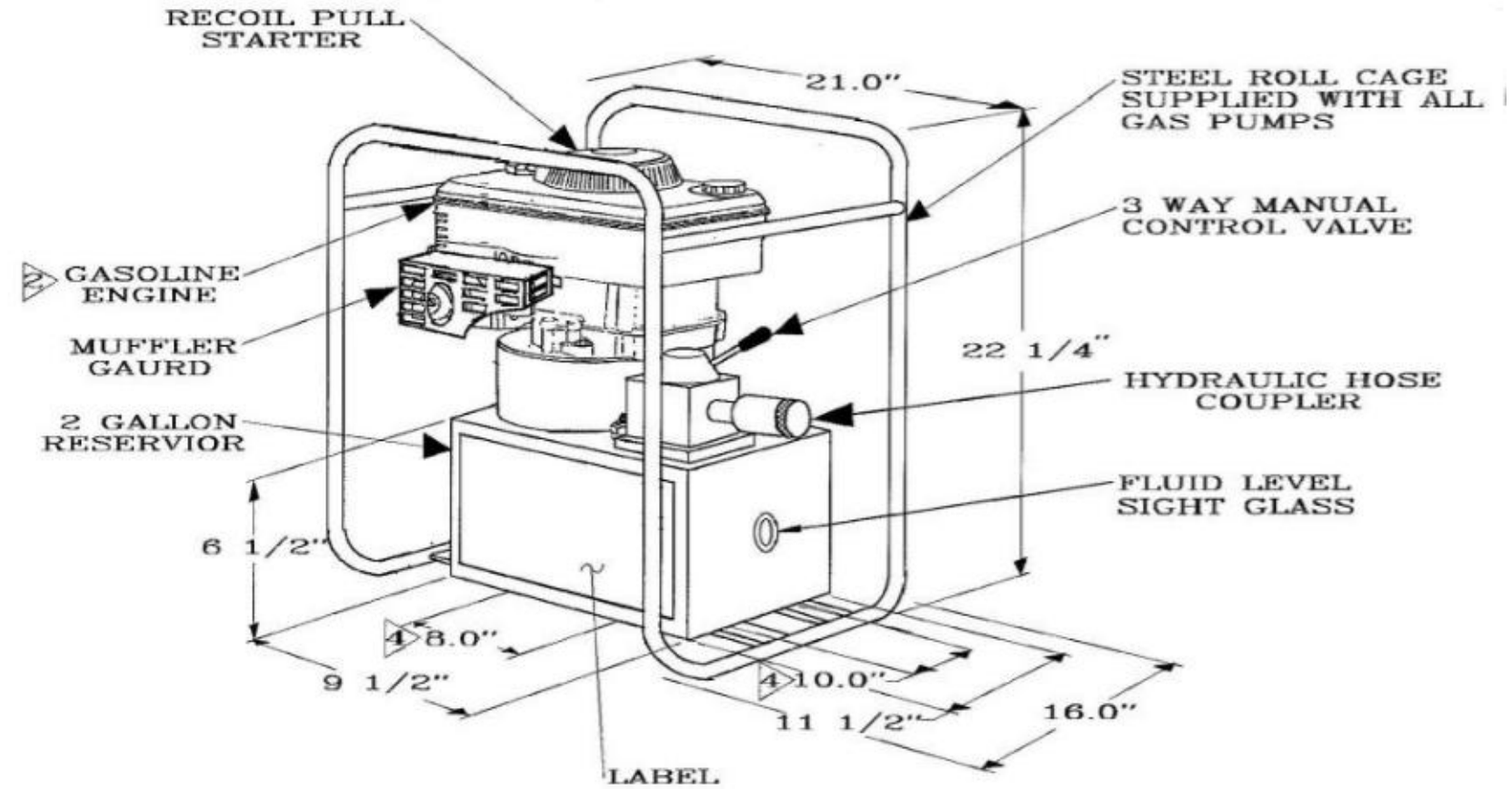

FEATURES:

- GAS ENGINE: EASY STARTING 4 CYCLE. 4HP, QUIET, BRIGGS & STRATTION.
- CONTROL VALVE: 3 WAY VALVE FEATURES RAM ADVANCE, RAM HOLD. AND NEUTRAL (RAM RETRACT).
- ROLL CAGE: HEAVY DUTY STEEL HELPS PROTECT RESERVOIR AND ENGINE FROM DAMAGE CAGE PROVIDES A STABLE STANCE AND EASES TRANSPORTATION.
- AUDIABLE POP INDICATES PROPER CRIMP PRESSURE WAS ACHIEVED.
- REFERENCE TO ENGINE HORSEPOWER = 8.5 HP. PER BILL BENEDICT.

NOTES:

- BURNDY ALFLUID™ HYDRAULIC OIL PROVIDED WITH UNIT (SEE RESERVOIR LABEL FOR FILLING INSTRUCTIONS). GASOLINE ENGINE PREFILLED WITH CRANKCASE OIL. ALWAYS CHECK FLUID LEVELS PRIOR TO PUMP OPERATION.
- GAS ENGINE: FOLLOW RECOMMENDATIONS AS DESCRIBED IN THE BRIGGS & STRATTON OWNERS MANUAL SUPPLIED WITH UNIT.
- READ PUMP OPERATING & MAINTENANCE INSTRUCTIONS MANUAL PRIOR TO OPERATING.
- THIS DIMENSION REPRESENTS THE DISTANCE BETWEEN MOUNTING BOLTS.

SPECIFICATIONS:

RESERVOIR CAPACITY: 8 QUARTS (6 QUARTS USABLE)  
 HYDRAULIC FLUID TYPE: BURNDY ALFLUID™  
 LENGTH: 21" (LESS ROLL CAGE 18")  
 WIDTH: 16" (LESS ROLL CAGE 13")  
 HEIGHT: 22 1/4" (LESS ROLL CAGE 13")  
 DRY WEIGHT: 78 LBS (INCLUDES ROLL CAGE)  
 OUTPUT PRESSURE: SEE TABLE  
 GAS ENGINE: 4HP, 4CYCLE

TO ORDER BURNDY® PRODUCTS CALL		GASOLINE HYDRAULIC PUMP	
UNITED STATES 1-800-346-4175 (LONDONDERRY, NH)		ITEM NO: N/A	
CANADA: 1-800-361-6975 (QUEBEC) 1-800-387-6487 (ALL OTHER PROVINCES)		CAT. NO: SEE TABLE	
FOR PRODUCT INFO: <a href="http://www.burndy.com">http://www.burndy.com</a>		DRAWN BY: JSG 3/16/1992	
		CHECKER: DF 3/18/1992	
		DSN APRV: JL 3/30/1992	
		MFG APRV: BENEDICT W 7/21/2014	
		QA APRV: C KOWALCZYK 7/22/2014	
		MKT APRV: RZASA M 7/17/2014	
		PROJ #:	
		SIZE	
		DRAWING NO	
		REV	
		SE..207683-01	
		A	
		SHEET 1 OF 1	