



SAFETY OPERATING & MAINTENANCE INSTRUCTIONS
(ENGLISH)

PATRIOT® IN-LINE® MD-LW SERIES



TABLE OF CONTENTS (English)

Safety Information	3
Description.....	5
Specifications	6
Features and Benefits	7
Specifications - Hydraulic Power Source.....	8
Pre-Operation	8
Operation.....	9
Crimping and Instructions	11
Maintenance	13
Service.....	14
Troubleshooting.....	15
Commonly Asked Questions	16
Parts Section	17
Battery Recycling.....	18

For information only, contact:

BURNDY® TOOL SERVICE CENTER
 150 Burndy Road
 Littleton, NH 03561 USA
 or call, toll free 1-800-426-8720
 ToolService@burndy.com

Additional or replacement manuals may be obtained free of charge from the BURNDY® Tool Service Center.

SAFETY INFORMATION



The above symbols are used to call your attention to instructions concerning your personal safety. Look for these symbols; read and follow the instructions that accompany them. Failure to follow the safety information provided can lead to serious personal injury or death.

SAFETY FIRST

! WARNING



The information provided in this manual is essential for the safe handling, operation, and maintenance of the BURNDY® PATRIOT® IN-LINE® Series. The operator must read, understand, and follow these instructions and ALL safety warnings and labels before operating these tools.

- Only use these tools in accordance with the manufacturer's specifications. Other use of these tools may lead to serious personal injury or death.

Each employer shall instruct each employee and user in the recognition and avoidance of unsafe working conditions and the laws and regulations applicable to his/her work environment to control or eliminate any hazards or other exposure to illness or injury. Reference: OSHA 29CFR 1910 etseq. (1994).

If a conflict arises between the material contained in this manual, rules of the user, his/her employer or company, and legal or industry guidelines, the more stringent rules take precedence and must be followed.

Observe and follow all other safety rules and regulations for the job.

Safety is everyone's responsibility.

<u>SYMBOL</u>	<u>MEANING</u>
DANGER	Hazard has a high level of risk.
WARNING	Hazard has a medium level of risk.
CAUTION	Hazard has a low level of risk.

OPERATING SAFETY PRECAUTIONS

WARNING



Tools are NOT insulated for use on or near energized conductors. Use of these tools near energized conductors may lead to electrical shock, causing severe injury or death.



Pinch point hazard. Crimp ram operates at high speed and force and can cause severe personal injury. Keep all body parts away from moving parts of the tool, especially the area of the head and die holder during operation.



Blade hazard. Cutter blades move at high speed and force and can cause severe personal injury. Keep all body parts away from moving parts of the tool during operation.



Blade hazard. Cutter blades have sharp edges that may cause personal injury while not in use or during blade replacement or installation. Use caution and personal protective equipment when handling tool and blades.



Projectile hazard. Cutter blades may break during operation due to stress cracks or misapplication. Always carefully inspect blades before use to avoid serious personal injury.



Projectile hazard. Operator must clear all bystanders from the work area especially when cutting cable and rebar ends to avoid potential injury to bystanders.



Hydraulic fluid under pressure. Do NOT use any part of your body to locate a hydraulic leak. Escaping fluid under pressure can cause severe injury or death. If injury results from escaping hydraulic fluid, seek immediate medical attention to avoid serious bodily injury.



Do NOT over-reach while operating this tool. Loss of balance can cause serious personal injury or death. Move closer to work area and securely support yourself and your work. ALWAYS keep proper footing and balance.

Always clip one end of the lanyard to the safety ring on the tool and the other end to a secure point to avoid accidental drop of more than 6 feet. Failure to follow this instruction may result in personal injury or tool damage.



Use all appropriate personal safety equipment when handling, operating, and servicing this tool such as: safety shoes, hard hat, eye and ear protection, work gloves, and sleeves.

To help ensure safe operation of this tool, keep all safety labels clean and legible. Replace labels when necessary with new labels. See PARTS SECTION of this manual for information on reordering.

USE

This tool has been specifically designed for use with BURNDY® products. Use of non BURNDY® products is limited to those which conform to BURNDY® Technical Specifications applicable to the tool. Use of non BURNDY® non-conforming products with the tool shall be deemed misuse or abuse.

IMPORTANT

When storing the tool, the following steps should be followed to avoid potential injury:

- Engage the activation trigger lock
- Remove battery
- Position tool jaws-down in the tool bag

DESCRIPTION

The BURNDY® PATRIOT® IN-LINE® Crimper/Cutter is a battery-actuated tool that incorporates a high-speed hydraulic pump, generating 6 tons of output force at the jaws. Due to its light weight, the tool can be operated with one hand for advance, retract and hold functions. The design offers a precisely-tuned pressure relief valve to ensure consistent compression connections every time. It also features interchangeable jaws and a rotating head for versatility in any situation.

Tool accepts 18V Makita Lithium Ion batteries, BL Series of size 2.0 Ahr and greater if the plastic battery clip in the tool has a "star" molded into it. The "star" identifies acceptance of the BL series batteries.

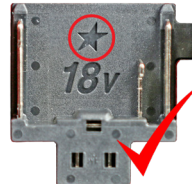

NOTE: For tools which do not have a "STAR" molded into the plastic battery clip, use is limited to the BL1830 (3.0 Ahr) battery. Forcing any other battery into this tool will void the warranty. Remove battery prior to placing tool in storage.

The BURNDY® PATRIOT® IN-LINE® Crimpers use standard BURNDY® "W" and "X" dies for use with off-the-shelf BURNDY® connectors available world-wide. It will install a full range of service entrance connectors, splices, terminals, stacking lugs, stirrups, repair sleeves and many other applications.

See the PARTS SECTION of this manual for information on reordering replacement parts and accessories.

PATENTS

This tool is protected by U.S. Patents: 7487654, 5727417

SPECIFICATIONS: PATRIOT® IN-LINE® MD-LW CRIMPER/CUTTER SERIES PATMD6LW, PATMD68LW, and PATMD66LW CRIMPERS PATMDCUTLW CUTTERS Jaws with Cutting Blades

Uses BURNDY® "W" & "X" Type Dies

Crimp Force..... 6 tons (5.4 Metric Tons)
Crimp Capacity*..... See Chart Below
Tool Weight..... 6.7 lbs (2.9 kg)
Length..... 18.7 in (475 mm)
Width..... 2.8 in (71 mm)
Height..... 4.3 in (109 mm)
Operating Voltage..... 18 V-DC
5.0 Ah Battery (90 Wh) Recharge Time..... <45 mins
3.0 Ah Battery (54 Wh) Recharge Time..... <30 mins

* CRIMP CAPACITY

Connector Type	Conductor Type	Size Range
Terminals and Splices	Copper	#8 AWG-500 kcmil
	Flex Copper	#8 AWG-350 kcmil
	Aluminum (AAC)	#8 AWG-350 kcmil
Full-Tension	ACSR	#10-4/0 AWG
Taps	Copper	#10-2/0 AWG
	Aluminum	#14-4/0 AWG
	ACSR	#14-4/0 AWG
Stirrups	ACSR	#6-4/0 AWG

PATMD-LW w/ PATMD430LWJAW DIELESS CRIMPING JAW

Crimp Force..... 6 tons (5.4 Metric Tons)
Crimp Capacity***..... See Chart
Tool Weight..... 6.7 lbs (2.9 kg)
Length..... 18.1 in (460 mm)
Width..... 2.8 in (71 mm)
Height..... 4.3 in (109 mm)
Operating Voltage..... 18 V-DC
5.0 Ah Battery (90 Wh) Recharge Time..... <45 mins
3.0 Ah Battery (54 Wh) Recharge Time..... <30 mins

Uses BURNDY® Multi-purpose ACSR or CU/AL Blades

Cutting Force..... 6 tons (5.4 Metric Tons)
Cutting Capacity**..... See Chart Below
Tool Weight..... 7.2 lb (3.3 kg)
Length..... 19.4 in (493 mm)
Width..... 2.8 in (71 mm)
Height..... 4.3 in (109 mm)
Operating Voltage..... 18 V-DC
5.0 Ah Battery (90 Wh) Recharge Time..... <45 mins
3.0 Ah Battery (54 Wh) Recharge Time..... <30 mins

** CUT CAPACITY

Conductor Type	CU/AL Jaw Max Size	ACSR Jaw Max Size	Guy Wire Jaw Max Size
Copper (Soft Drawn)	600 kcmil	350 kcmil	--
Aluminum (AAC)	636 kcmil	636 kcmil	--
ACSR (26/7)	--	556.5 kcmil	--
Guy Wire (EHS)	--	--	3/8"

*** PATMD430LWJAW CRIMP CAPACITY

Connector Type	Conductor Type	Size Range
Full Tension Splices (YDS-RL ¹ , YDSR-RL ¹ , YDS-RLY ²)	AAC, AAAC, ACSR	#4 - 3/0 AWG
Full Tension Reducers (YDR-RL, YDRR-RL)	AAC, AAAC, ACSR	#4 - 1/0 AWG
Partial Tension Terminals and Splices ³ , (YCA-RL, YCS-RL)	AAC, AAAC, ACSR	#4 - 3/0 AWG
Service Splices (YSS-R)	AAC, AAAC, ACSR	#4 - #2 AWG

¹YDS4RL and YDSR4RL with #4 AAC is rated for ANSI C119.4 Class 1A normal tension (60% RBS). All others in family are rated for ANSI C119.4 Class 1 full tension (95% RBS) for all conductors and sizes shown.

²YDS4RLY with #4 AAC and #4 ACSR is rated for ANSI C119.4 Class 1A normal tension (60% RBS). All others in family are rated for ANSI C119.4 Class 1 full tension (95% RBS) for all conductors and sizes shown.

³YCA-RL terminals and YCS-RL splices are rated for ANSI C119.4 Class 2 partial tension (40% RBS).

FEATURES AND BENEFITS

FEATURE	BENEFIT
- True one-handed operation for cutting and crimping medium size cable and connectors	- Easy tool operation
- High-speed hydraulic pump	- Fast and accurate crimps and cuts
- Rotatable head	- Allows for cutting in many positions
- Long battery life	- Increased crimps and cuts per charge
- Ergonomically balanced tool	- Eases operation and helps lessen fatigue
- State of the art head and jaw design	- Allows use of standard BURNDY® dies and connectors
- Large hand grip area	- Easier operation with gloves
- Excellent pump efficiency	- Smoother and more efficient tool operation
- Industry-standard battery and charger	- Rugged, time-proven design
- Audible pressure "pop-off" valve	- Indicates properly completed crimps and cuts
- Interchangeable jaws	- More flexibility for crimping and cutting with multiple jaw options
- Scissor-action crimping and cutting jaws	- Easier access to small areas and easier splice crimping or mid-span cutting than latch-head cutters
- Two "High Capacity" 18V batteries and charger	- Allows interruption free operation by charging one battery while the other is in use
- Uses Lithium-ion batteries	- Charging memory is no longer a concern
- Durable tool bag	- Provides superior protection and stores accessories
- 5 Year warranty on tool, excluding blades; 3 years on batteries & charger	- Customer satisfaction and technical support
- INFINITY DRIVE® Transmission	- Superior reliability and lifetime warranty

SPECIFICATIONS - HYDRAULIC POWER SOURCE

WARNING

The internal hydraulic power source achieves very high fluid pressure during normal operation. Do NOT disassemble this tool at any time. Disassembly of this tool may result in severe personal injury or tool damage and will void the warranty.

The hydraulic power system is a non-field serviceable item. If you suspect that your tool is not functioning properly, please contact the BURNDY® Tool Service Center: 1-800-426-8720, ToolService@burndy.com

PARTS OF THE TOOL

Before using the PATRIOT® IN-LINE® tool, take a moment to familiarize yourself with the parts of the tool. Doing so will make you aware of the terms used in the following sections.

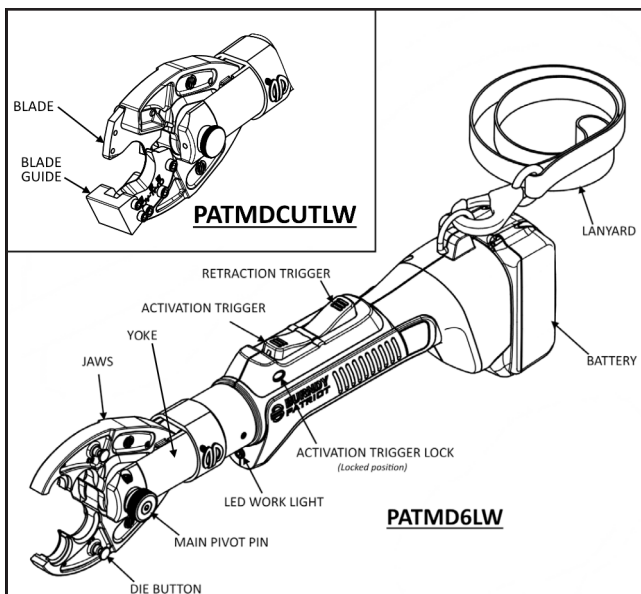

PRE-OPERATION INSTRUCTIONS

WARNING

Read and follow all pre-operation and safety instructions provided for your tool and for the battery charger (see Battery Charger Instruction Manual) and accessories. Failure to follow the proper operating instructions and safety information provided can lead to serious personal injury or death.

Before operating your PATRIOT® IN-LINE® Crimper/Cutter, carefully read and follow these PRE-OPERATION instructions to ensure your tool is in proper working condition. Read and follow the Battery Charger Instruction Manual included for operating your battery charger unit. Following these instructions, charge the battery(s).

NOTE: Before proceeding to step 1, engage the Actuation Trigger Lock Button and then Remove Battery.

1. Depress the upper black retraction trigger first, to make certain that the tool jaws are fully opened.
2. Ensure all body parts are away from pinch point jaws prior to operating tool.
3. With a fully charged battery installed, depress the lower green activation trigger until the jaws of the PATRIOT® IN-LINE® crimper/cutter close. You will hear an audible pop when the tool has reached maximum output and the cycle is complete.

Please note that it is not necessary to have a battery installed in the tool in order to retract the tool jaws.

JAW INSTALLATION PROCEDURE

One of the main features of the BURNDY® PATRIOT® IN-LINE® Crimper/Cutter tool is its ability to easily change out and install different types of jaws, without the need for any additional tools. There are several different types of jaws for crimping and cutting, so it may be necessary to switch jaws depending on the application. (See *Parts Section to order other jaw variations.*)

- 1) Engage the activation trigger lock and then remove battery.
- 2) Press the black retraction trigger to ensure the ram is fully retracted.
- 3) Grip the knurled end of the main pivot pin and pull outward. Turning the pin while pulling will make it easier to get past the detent and pull outward. (Note: The pin will not pull out of the yoke completely.)
- 4) Squeeze the jaws slightly and remove the jaws from the tool.
- 5) Insert new jaws into the yoke by closing the jaws slightly in your hand. Line up the tabs at the base of the jaws with the notches in the yoke.
- 6) Push the pin inward so that it is fully inserted into the jaws and yoke.

DIE INSTALLATION PROCEDURE

For the majority of crimped connections, it is necessary to select and install the appropriate die for the application. Please refer to the connector catalog page or the die index number shown on the connector to determine the correct die set.

To Install:

- 1) Select the appropriate die for the application.
- 2) Engage the activation trigger lock and then remove battery.
- 3) Push in die button while inserting the die into the crimp jaws. The second die may have to be installed via the top of the tool. (Note: For polarized dies – W28RT for example – orient the dies in the crimp jaws according to the arrow stamped on the die.)

To Remove:

- 1) Engage the activation trigger lock and then remove battery.
- 2) Push in die button while removing the die.
Note: The first die may have to be removed out the top of the tool.

BLADE REPLACEMENT PROCEDURE

If the blades wear out, it will be necessary to change out and install new blades. (See *Parts Section to order new blades and guide.*)

Required Tools: 9/64" Allen Wrench, 5/32" Allen Wrench

- 1) Engage the activation trigger lock and then remove battery.
- 2) Remove the guide by removing the #8-32 socket head cap screws.

BLADE REPLACEMENT *Continued*

- 3) Remove each blade by removing the three #10-32 x 1/2" socket head cap screws on both sides.
- 4) Install the new blades and secure with the three #10-32 x 1/2" cap screws on each side.
- 5) Install the blade guide and secure with the #8-32 socket head cap screws.
- 6) Be sure that all screws are tight before operating the tool.
- 7) Cycle the tool. Make sure that there is no interference and that the jaws advance and retract smoothly.

OPERATION

WARNING



Read and follow all pre-operation and safety instructions provided for your PATRIOT® IN-LINE® Crimper/Cutter and for the battery charger (see Charger Instruction Manual) and accessories. Failure to follow the proper operating instructions and safety information provided can lead to serious personal injury or death.



This tool is NOT insulated for use on or near energized conductors. Use of this tool near energized conductors may lead to electrical shock, causing severe injury or death.



Pinch point hazard. Crimp ram operates at high speed and force and can cause severe personal injury. Keep all body parts away from moving parts of the tool, especially the area of the head and die holder during operation.



Blade hazard. Cutter blades move at high speed and force and can cause severe personal injury. Keep all body parts away from moving parts of the tool during operation.

NOTE: Do not immerse the tool in water, as the PATRIOT® IN-LINE® Crimper/Cutter is not designed to operate under water. This is considered abuse and will void the warranty! Always use the tool lanyard provided to prevent dropping the PATRIOT® IN-LINE® Crimper/Cutter.

OPERATION INSTRUCTIONS

PATMDCUTLW Cutter Only:

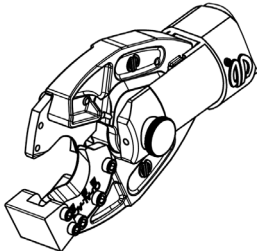

1. Read and follow the PRE-OPERATION instructions and Battery Charger Instruction Manual.
2. Ensure that the ram is fully retracted by depressing the black retraction trigger.
3. Inspect the blades for wear or damage, especially on the cutting edge. If cracks, chips or other damage is found, discontinue use and replace blades according to the blade replacement procedure.
4. If cutting less than 6 inches from the end of uninsulated cable, it may be required to wrap tape around the cable in the area to be cut to prevent the strands from separating during cutting. If the cable is not taped, this may prevent the tool from cutting or retracting properly, and could damage the blades.
5. Insert a battery into the tool according to the PRE-OPERATION instructions and dis-engage the activation trigger lock only after all body parts are clear of the jaw pinch point.
6. Insert cable into the tool.
7. Holding the tool perpendicular to the length of the cable, depress the green activation trigger until the cutting cycle is complete. If tape has been applied (see step 4), be sure to cut directly on the tape.
8. Depress the black retraction trigger to retract the ram and return the cutting blades to their original position.

Note: If the blades do not retract with the ram, a small chip may be caught between the blades. In this case, rest one side of the jaw on a stable surface and use a soft hammer or rubber mallet and tap the back end of the jaw until the blades release. See **Figure 1** below.

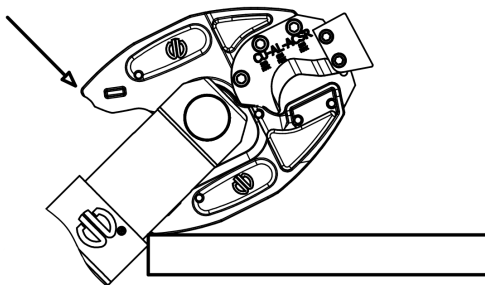
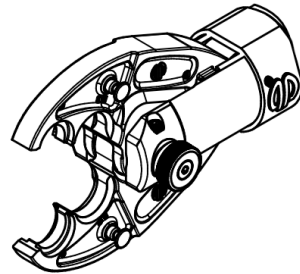

Figure 1

PATMD-LW Crimpers Only:



1. Read and follow the PRE-OPERATION instructions and Battery Charger Instruction Manual.
2. Ensure that jaws are fully open by depressing the black retraction trigger.
3. Select and install the appropriate die set, if applicable, for the connector and cable combination being crimped. Insert a battery into the tool and disengage the activation trigger lock only after all body parts are clear of the jaw pinch point.
4. Position the tool properly on the connector making certain that the die is aligned over the crimp area indicators.
5. Insert the conductor into the connector, depress and hold the green activation trigger to advance the tool.
6. Continue holding green activation trigger forward until you hear the audible "pop" signifying the crimp is complete.
7. Depress and hold the black retraction trigger until ram fully retracts, or enough to move to next crimp location if multiple crimps are required.
8. Continue crimping the connector until the proper number of crimps have been completed. Work from the center to the outer edges for splices and "H" frame connectors, alternating sides if possible, for the best compression connection. Remove tool from connection.

DIELESS CRIMPING INSTRUCTIONS:

1. Place tool around the connector so that it rests in the next side of the jaw.

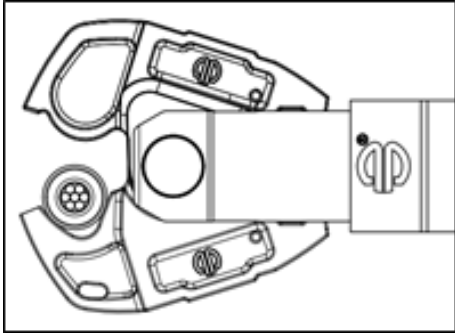

2. Make the first crimp in the middle of the splice next to the knurled area.

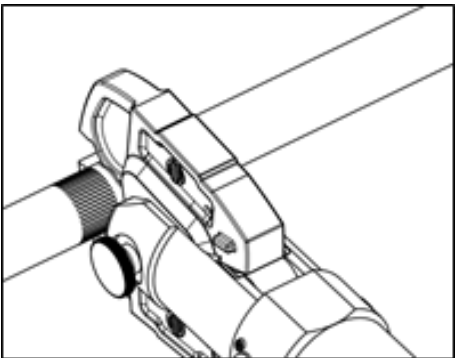

3. Once the crimp is completed, rotate the tool head 180 degrees. *Note: Only the jaws need to be rotated. Rotating the entire tool is not necessary.*

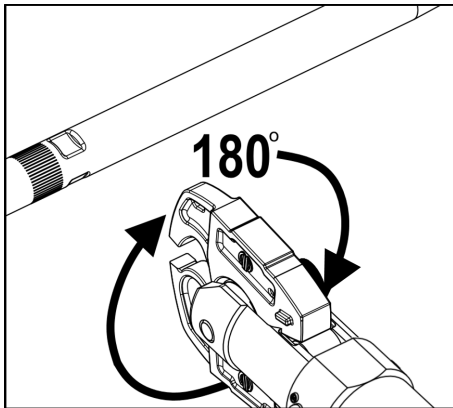

4. Make the second crimp about 1/16" after the first crimp.

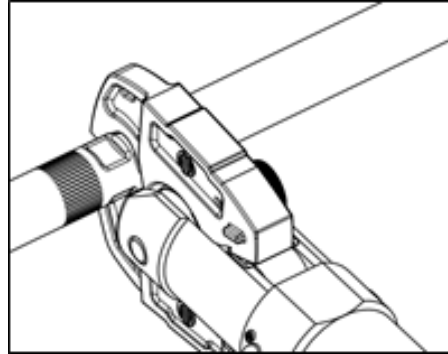

5. Continue crimping, rotating the tool between each crimp, until the splice is completely crimped. **DO NOT CRIMP ON THE TAPERED SECTIONS.** See crimp chart for correct number of crimps for each side of the splice.

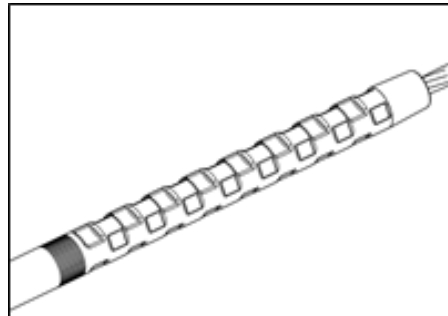

PATMD430LWJAW Dieless Scissor Jaw

Crimp Chart:

Series	Conductor Size (AAC, AAAC, ACSR)	Connector Catalog Number	# Crimps per Side
YDS-RL, YDSR-RL, YDS-RLY	#4 AWG	YDS4RL ¹ , YDSR4RL ¹ , YDS4RLY ^{2 4}	11
	#2 AWG	YDS2RL, YDSR2RL, YDS2RLY	9
	#2 AWG	YDS021RL, YDS021RLY	10
	1/0 AWG	YDS25RL, YDSR25RL, YDS25RLY	14
	2/0 AWG	YDS26RL, YDSR26RL, YDS26RLY	12
	3/0 AWG	YDS27RL, YDSR27RL, YDS27RLY	16
YDR-RL, YDRR-RL	#4 - #2 AWG	YDRR2R4RG1	11
	#4 - 1/0 AWG	YDR25R4RL, YDRR25R4RL	11
	#2 - 1/0 AWG	YDR25R2RL, YDRR25R2RL	10
YCS-RL ³	#4 AWG	YCS4RL	4
	#2 AWG	YCS2RL	4
	1/0 AWG	YCS25RL	4
	2/0 AWG	YCS26RL	4
	3/0 AWG	YCS27RL	4
YCA-RL ³	#4 AWG	YCA4RL-	4
	#2 AWG	YCA2RL-	4
	1/0 AWG	YCA25RL-	4
	2/0 AWG	YCA26RL-	4
	3/0 AWG	YCA27RL-	4
YSS-R	#4 AWG	YSS4R	3
	#2 AWG	YSS2R	3

¹ YDS4RL and YDSR4RL with #4 AAC is rated for ANSI C119.4 Class 1A normal tension (60% RBS). All others in family are rated for ANSI C119.4 Class 1 full tension (95% RBS) for all conductors and sizes shown.

² YDS4RLY with #4 AAC and #4 ACSR is rated for ANSI C119.4 Class 1A normal tension (60% RBS). All others in family are rated for ANSI C119.4 Class 1 full tension (95% RBS) for all conductors and sizes shown.

³ YCA-RL terminals and YCS-RL splices are rated for ANSI C119.4 Class 2 partial tension (40% RBS).

⁴ 1/16" spacing between crimps cannot be maintained on YDS4RLY. Crimps on this splice should be directly adjacent to one another.

MAINTENANCE

PREVENTIVE MAINTENANCE



CAUTION

Failure to perform regular maintenance tasks could result in bodily injury and/or property damage.

The service life of a tool can be greatly improved with proper care and maintenance. To extend the life of your battery tool, follow the recommended maintenance tasks outlined below.

- Always engage the activation trigger lock button and then remove the battery prior to working on the tool.
- Keep the tool exterior clean at all times. Remove dirt, debris, and other foreign substances from external surfaces daily to help prevent corrosion and damage to the tool, the ram, and piston mechanism.
- Remove all surface contaminants. When surface contaminants cannot be removed with a cloth, spray jaws and yoke with a general purpose cleaning solution to help loosen contaminants. The cleaning solution must be recommended for cleaning steel and aluminum. Avoid getting solvents onto the plastic housing as some cleaners and solvents may damage the housing material. Using a stiff brush, never metal, remove all contaminants in and around the ram and piston area and allow solvent to drain off tool.
- The tool ram must be fully retracted before cleaning, removing, or installing the jaws. To clean the jaws or to swap out the jaws, first engage the activation trigger lock button, remove the battery, then release the pivot pin to remove the jaws. Clean the cam surface, release pin, and lastly, clean the rollers located inside of the yoke. Apply a light film of grease to the cam surface, release pin, and rollers. Install the jaws and ensure the release pin is fully inserted prior to operating the tool. When operating in dirty environments the jaws may need to be cleaned more often.
- Extreme care should be taken to prevent contaminants from entering the hydraulic system. The tool hydraulic circuit is a closed system. Replacement of hydraulic fluid or topping off of hydraulic fluid by the user is NOT recommended.
- Inspect the tool for signs of leaks, cracks, wear, or damage.
- Lightly lubricate the external ram and piston surfaces and die buttons with a high-grade silicon lubricant.
- Wipe the tool with a clean, dry rag before placing the tool into the case.

SERVICE

WARNING

We do not recommend you attempt to service or repair any tool yourself. Tool servicing by unqualified personnel will void the warranty and may lead to serious personal injury.

DISASSEMBLY OF THE TOOL IS NOT RECOMMENDED. RETURN THE TOOL TO THE BURNDY® TOOL SERVICE CENTER OR BURNDY® AUTHORIZED TOOL REPAIR CENTER. IF YOU REQUIRE ADDITIONAL INFORMATION
CALL: 1-800-426-8720
ToolService@burndy.com

When battery pack is not in use, keep it away from other metal objects like paper clips, coins, keys, nails, screws, or other small metal objects that can make a connection from one terminal to another. Shorting the battery terminals together may cause burns or a fire.

Under abusive conditions, liquid may be ejected from the battery, avoid contact. If contact accidentally occurs, flush with water. If liquid contacts eyes, additionally seek medical help. Liquid ejected from the battery may cause irritation or burns.

IMPORTANT SAFETY INSTRUCTIONS FOR BATTERY CARTRIDGE

1. Before using battery cartridge, read all instructions and cautionary markings on (1) battery charger, (2) battery, and (3) product using battery.
2. Do not disassemble battery cartridge.
3. If operating time has become excessively shorter, stop operating immediately. It may result in a risk of overheating, possible burns and even an explosion.
4. If electrolyte gets into your eyes, rinse them out with clear water and seek medical attention right away. It may result in loss of your eyesight.
5. Do not short the battery cartridge: (1) Do not touch the terminals with any conductive material. (2) Avoid storing battery cartridge in a container with other metal objects such as nails, coins, etc. (3) Do not expose battery cartridge to water or rain. A battery short can cause a large current flow, overheating, possible burns and even a breakdown.
6. Do not store the tool and battery cartridge in locations where the temperature may reach or exceed 50°C (122°F).
7. Do not incinerate the battery cartridge even if it is severely damaged or is completely worn out. The battery cartridge can explode in a fire.
8. Be careful not to drop or strike battery.

TROUBLESHOOTING

It is not recommended that the end user attempt to perform repairs on this tool, as specialized tools, training, and/or procedures may be required.

Should you have any problems or questions with your BURNDY® hydraulic tooling, please do not hesitate to contact the BURNDY® Customer and Technical Service Departments by calling 1-800-346-4175, or the BURNDY® Tool Service Center for tool servicing and repair related questions at 1-800-426-8720; ToolService@burndy.com.

TROUBLESHOOTING GUIDE

SYMPTOM / PROBLEM	CAUSE	REMEDY
Jaws do not close when activation trigger is pressed.	<ul style="list-style-type: none"> - Battery is not charged. - Ram release trigger/valve is being held open. - Pump is damaged. - Activation trigger switch failure. 	<ul style="list-style-type: none"> - Charge the battery according to the Battery Charger Instruction Manual provided with your tool. - Press and release the ram release trigger to reset the valve. - Return to factory for repair. - Return to factory for repair.
Jaws do not fully close.	<ul style="list-style-type: none"> - Hydraulic system failure. 	<ul style="list-style-type: none"> - Return to factory for repair.
Excessive or unusual noise from tool.	<ul style="list-style-type: none"> - Mechanical vibrations. - Cavitation due to cold hydraulic fluid. - Cavitation due to hot hydraulic fluid. 	<ul style="list-style-type: none"> - Return to factory for repair. - Allow tool to warm up before use. - Allow tool to cool before continuing use.
Oil leaks from tool.	<ul style="list-style-type: none"> - Seal defect or mechanical problems. 	<ul style="list-style-type: none"> - Return to factory for repair.
Number of crimps/cuts per charge decreases with each battery recharge.	<ul style="list-style-type: none"> - Battery is too warm due to frequent discharge/recharge cycling. 	<ul style="list-style-type: none"> - Allow battery to cool to room temperature before recharging. - Alternate batteries often.
Tool will not stop running after activation trigger is released.	<ul style="list-style-type: none"> - Activation trigger stuck. - Switch failure. 	<ul style="list-style-type: none"> - Remove battery and check for contaminants around the trigger switch area. - Remove battery and return to factory for repair.
Jaws/blades do not retract with the ram when the black retraction trigger is depressed. <i>(PATMDCUTLW only)</i>	<ul style="list-style-type: none"> - Chip is caught between blades or there is another interference in the blade or guide area. 	<ul style="list-style-type: none"> - See OPERATION INSTRUCTIONS section and follow the instructions in the note. - If cutting less than 6 inches from the end of the cable, wrap cable with tape, and cut on the taped area.
Audible "pop" is heard before cable is cut or crimped.	<ul style="list-style-type: none"> - Cable is larger or a harder material than is recommended. - Blades are dull or chipped. - Pressure relief valve setting is set too low. 	<ul style="list-style-type: none"> - See SPECIFICATIONS section and only cut within the tool's cutting capacity. - Replace blades. - Return to factory to have the valve setting increased.
When installing new jaws, the pin does not line up with the hole	<ul style="list-style-type: none"> - Ram is not fully retracted. 	<ul style="list-style-type: none"> - Press the black retraction trigger to retract the ram fully OR - Squeeze jaws further than normal to line up the pin with the hole in the jaws.

COMMONLY ASKED QUESTIONS & ANSWERS:

1. **Q - How many crimps/cuts can I get before I need to recharge the battery?**

It is very difficult to estimate the amount of cuts/crimps you will get before recharging the battery. This will depend on many factors such as temperature, size, and type of material being cut or crimped, how the tool is used, the weather, etc. (see below for more information).

The weather - Extreme cold temperatures can reduce the battery charge by up to 60%. Keep charged batteries in a warm place, but not in your pockets, since coins and other metal parts may contact the battery terminal strips, causing a short circuit. Warm weather users will find they get more crimps/cuts per charge than users in colder climates.

The size and type of material being cut - All Copper, Aluminum, and ACSR cables, require different force to crimp/cut. Diameter is also a factor in determining how many crimps/cuts you can achieve before a recharge is needed. Some connectors and cables may require more frequent battery recharging.

How you use the tool - If you make multiple crimps/cuts, one right after another, you will need more frequent battery recharging than if you make a few and pause a moment prior to crimping/cutting again. Full retraction after each crimp/cut is not required if using small cables, while larger cables may require full retraction. Advancing the ram each time to approach small cables and connectors drains the battery faster than just retracting enough to move to the next crimp location.

The vast number of variables makes it difficult to provide exact number of crimps/cuts per charge for every possible field situation.

2. **Q - How long will the batteries last?**

Under ideal circumstances each battery could be recharged up to 1000 times before it will no longer accept a charge. This number may vary due to individual use and charging habits.

3. **Q - Can the batteries be recycled?**

YES! Once the battery no longer accepts a recharge, simply follow the recycling instruction included in this manual for proper recycling. If your local community or company has a recycling program, you may choose to contact them for instructions on recycling. Always properly dispose of spent batteries by following the manufacturers recommended recycling procedures. (See "BATTERY RECYCLING" section for details)

4. **Q - How far can the tool be dropped without damaging it?**

The PATRIOT® Crimper/Cutter has been designed to withstand drops of six feet; however, due to the endless angles at which a tool can be dropped, damage can still occur. The outer housing is designed of a high strength composite polymer plastic, but can be broken depending upon the surface (pavement, grass, rocks, etc.) being dropped upon and/or the angle of impact. The internal working assemblies should survive without damage. We strongly recommend that the tool restraint lanyard be used at all times to help prevent dropping the tool. Drops without the lanyard attached would be considered abusive treatment.

5. **Q - How do I know when I've properly completed a crimp?**

The PATRIOT® Crimper/Cutter produces an audible pop when the crimp/cut has been properly completed.

6. **Q - Does the tool require a charged battery in order to retract the ram?**

NO, the PATRIOT® Crimper/Cutter utilizes a mechanical retraction mechanism which allows the ram to retract without the battery.

Tips for maintaining maximum battery life

1. Charge the battery cartridge before completely discharged. Always stop tool operation and charge the battery cartridge when you notice less tool power.
2. Never recharge a fully charged battery cartridge. Overcharging shortens the battery service life.
3. Charge the battery cartridge with room temperature at 10°C - 40°C (50°F - 104°F). Let a hot battery cartridge cool down before charging it.
4. Charge the Lithium-ion battery cartridge when you do not use it for more than six months.

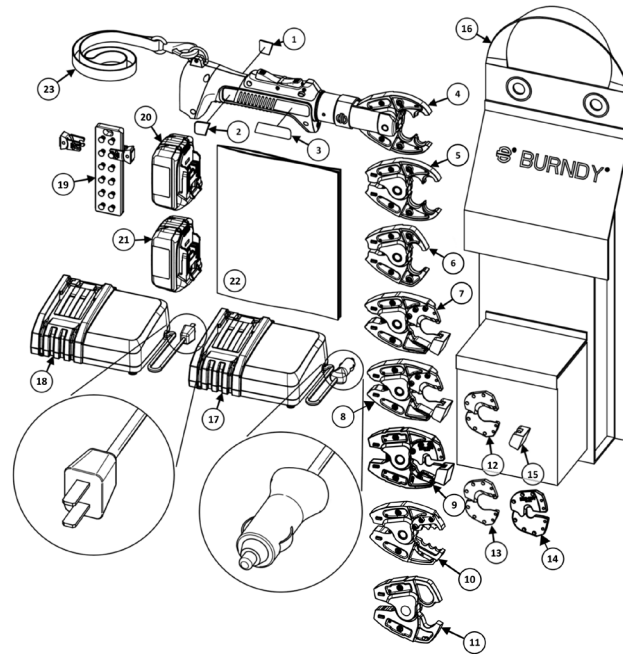
PARTS SECTION

#	CATALOG NUMBER	DESCRIPTION
1	PATMDLWLBLPRODL	PATMD Label, Left
2	PATMDLWLBLPRODR	PATMD Label, Right
3	PATMDLWLBLWRN	Warning Label
4	PATMD6LWJAW	Crimping Jaw with "D3" and "BG" Grooves
5	PATMD68LWJAW	Crimping Jaw with "D3" and "O" Grooves
6	PATMD66LWJAW	Crimping Jaw with "D3" Groove Only (Snub Nose)
7	PATMDCUTLWJAW	Cutting Jaw with ACSR Cutting Blades
8	PATMDCUTCLWJAW	Cutting Jaw with Cu/Al Cutting Blades
9	PATMDCUTGLWJAW	Cutting Jaw with Guy Wire Cutting Blades
10	PATMDXPJLWJAW	Crimping Jaw with Nicopress X, P, and J Grooves
11	PATMD430LWJAW	Dieless Crimping Jaw for Overhead Distribution Splices
12	PATMDCUTACSRKIT	Replacement Blades, 350 Cu/636 Al/556 ACSR Qty: 2
13	PATMDCUTCUALKIT	Replacement Blades, 600 Cu/636 Al, Qty: 2
14	PATMDCUTGUYKIT	Replacement Blades, 3/8" EHS Guy Wire, Qty: 2
15	PATMDCUTACSRFXGDE	Fixed Blade Guide with Mounting Hardware
16	TOOLBAGMDLI	Tool Bag
17	PATCHGRLIDC	Makita Lithium Ion Battery Charger (12V DC)
18	PATCHGRLI	Makita Lithium Ion Battery Charger (120V AC)
19	WDIETREE	W Die Tree, Holds Up To 6 Sets (Dies Sold Separately)
20	BAT18VLI	Makita 18V Lithium Ion Battery, 3.0 Ah
21	BAT18V5AHLI	Makita 18V Lithium Ion Battery, 5.0 Ah
22	PATMDLWSOMI	Safety, Operation And Maintenance Instructions (SOMI)
23	PT10074020	Wrist Strap

LITHIUM ION (Li-ion) SHIPPING REGULATIONS:

The U.S. DOT enacted new regulations in 2008 that apply to shipments containing Lithium ion batteries. Whenever possible, Lithium ion batteries should be sorted from other rechargeable batteries.

Shipment of a non-Call2Recycle container of Lithium ion batteries for recycling must adhere to the following requirements, in addition to the safety requirements listed on the opposite side:

- Each individual rechargeable battery, or cell phone with battery, must be placed into a separate bag (or terminals taped) to ensure safe storage and shipping;
- Package must be marked "CONTAINS LITHIUM ION BATTERIES – FORBIDDEN FOR TRANSPORT ABOARD AIRCRAFT AND VESSEL." Lettering must be at least 0.25 inches in height;
- Package also must be marked: "DO NOT DAMAGE OR MISHANDLE PACKAGE – IF PACKAGE IS DAMAGED, BATTERIES MUST BE QUARANTINED, INSPECTED AND REPACKAGED";
- Shipping document (e.g., BOL) must indicate package contains lithium batteries and package must be quarantined, inspected and repackaged if damaged; and
- Package may not exceed 30 kg (66 pounds)

A package containing Lithium ion batteries with a gross weight of more than 30 kg (66 pounds) must be shipped as a fully-regulated Class 9 hazardous material and marked "LITHIUM BATTERY, UN 3090" and carry the Class 9 Miscellaneous hazard label. Batteries must be protected from short circuits and placed in strong outer packaging or UN specification packaging. Shipments also must be accompanied by hazardous materials shipping paper. Shippers must be trained in accordance with the U.S. hazardous materials regulations.

Approved Battery Recycling Location:

BURNDY® encourages recycling of its products whenever feasible. Recycling regulations and methods vary within North America and BURNDY® does not endorse any one recycling method or company. Consumers that wish to recycle BURNDY® products in North America are asked to do so according to your local, state and federal regulations. Recycling resources for the United States can be found at the US EPA web site at the following link:

<http://www.epa.gov/recycle>

If you wish to recycle batteries please use the above link and/or contact your local RBRC recycling center. If additional information is needed please contact the BURNDY®, Littleton Tool Service Center

When recycling batteries you must include a bill of lading in order to comply with all applicable state and federal requirements, or the recycling center may be forced to return the shipment at your expense. If you have any questions, please contact the recycling center directly.

The EPA certified RBRC Recycling Seal indicates BURNDY® is voluntarily participating in a program to recycle these batteries at the end of their useful life. The RBRC program provides a convenient alternative to placing batteries into the trash, which may be illegal in your area. Please call 1-800-822-8837 for more information. BURNDY® is committed to preserving our environment and conserving natural resources.



SAFETY GUIDELINES FOR BATTERY COLLECTION LITHIUM ION BATTERIES

- Used batteries may have a significant residual charge. It is important that they are prevented from short-circuiting. This can be done by placing the batteries separately in plastic bags or by placing non-conductive tape over the battery terminals.
- While these batteries are normally safe to handle, they do contain caustic materials that may have "vented" due to misuse during the life of the battery. If the battery appears to be "dirty" or have a white "film-like" substance around the terminal, exercise caution when handling the battery. Do not touch the dirty area. Wash your hands with soap and water if they feel itchy, and avoid touching your eyes, nose, mouth.
- Do not attempt to discharge the battery by short-circuiting the terminals, consult your battery supplier for proper instructions on discharging batteries.
- Do not bite, or place the battery in your mouth or nose.
- Do not place wet batteries in a plastic bag. The trapped moisture will cause the battery to rust.

For more information write or call:

BURNDY® TOOL SERVICE CENTER

150 Burndy Road

Littleton, NH 03561 USA

or call, toll free 1-800-426-8720

ToolService@burndy.com

PATMDLWSOMI

Rev. K

Item #50054506