

REV.	DATE	DESCRIPTION	ECO	BY	C'H'K.
A	2020-01-01 00:00:00 EST	DRAWING RELEASED	210610009043	BAU	LBR

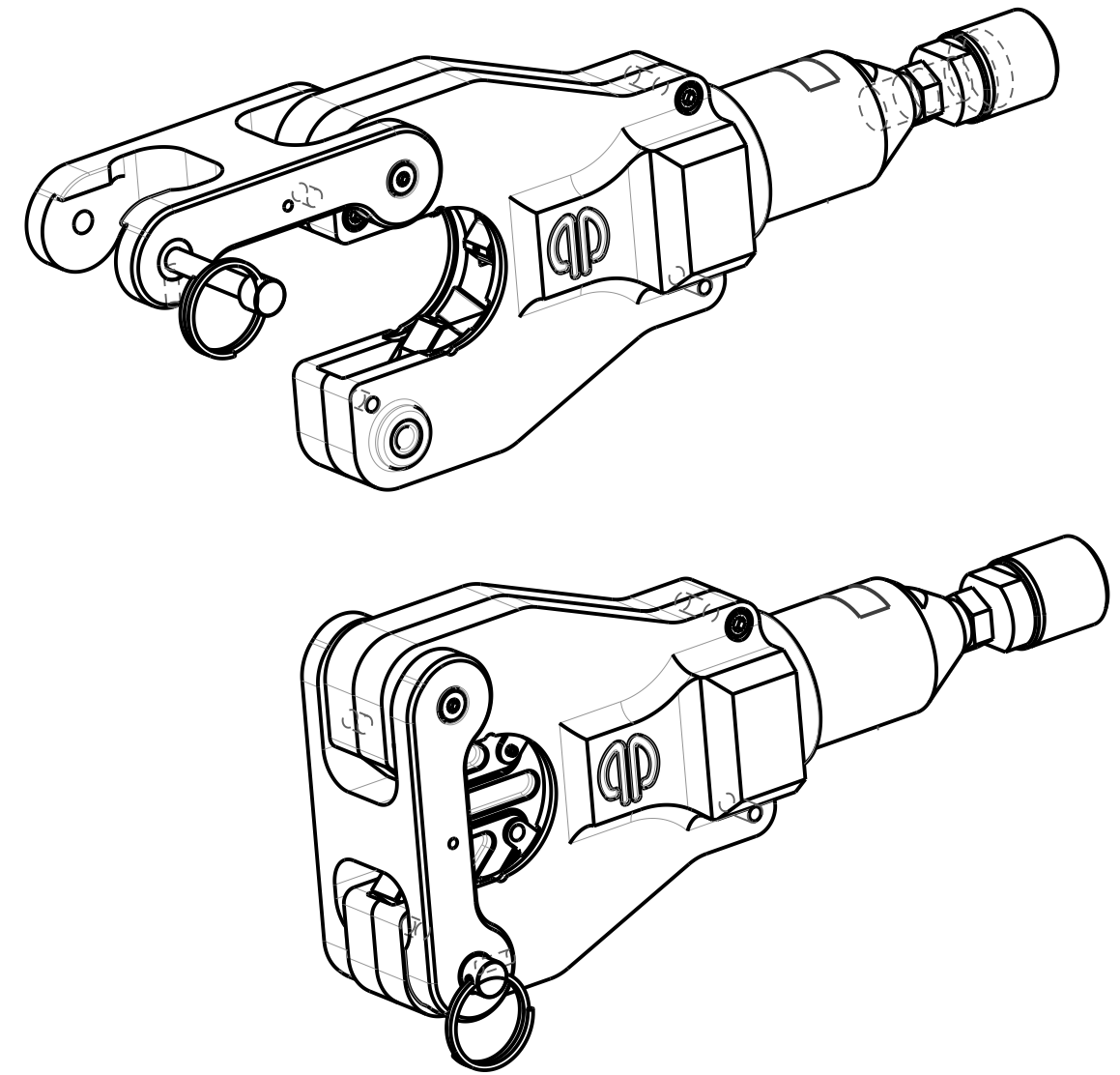
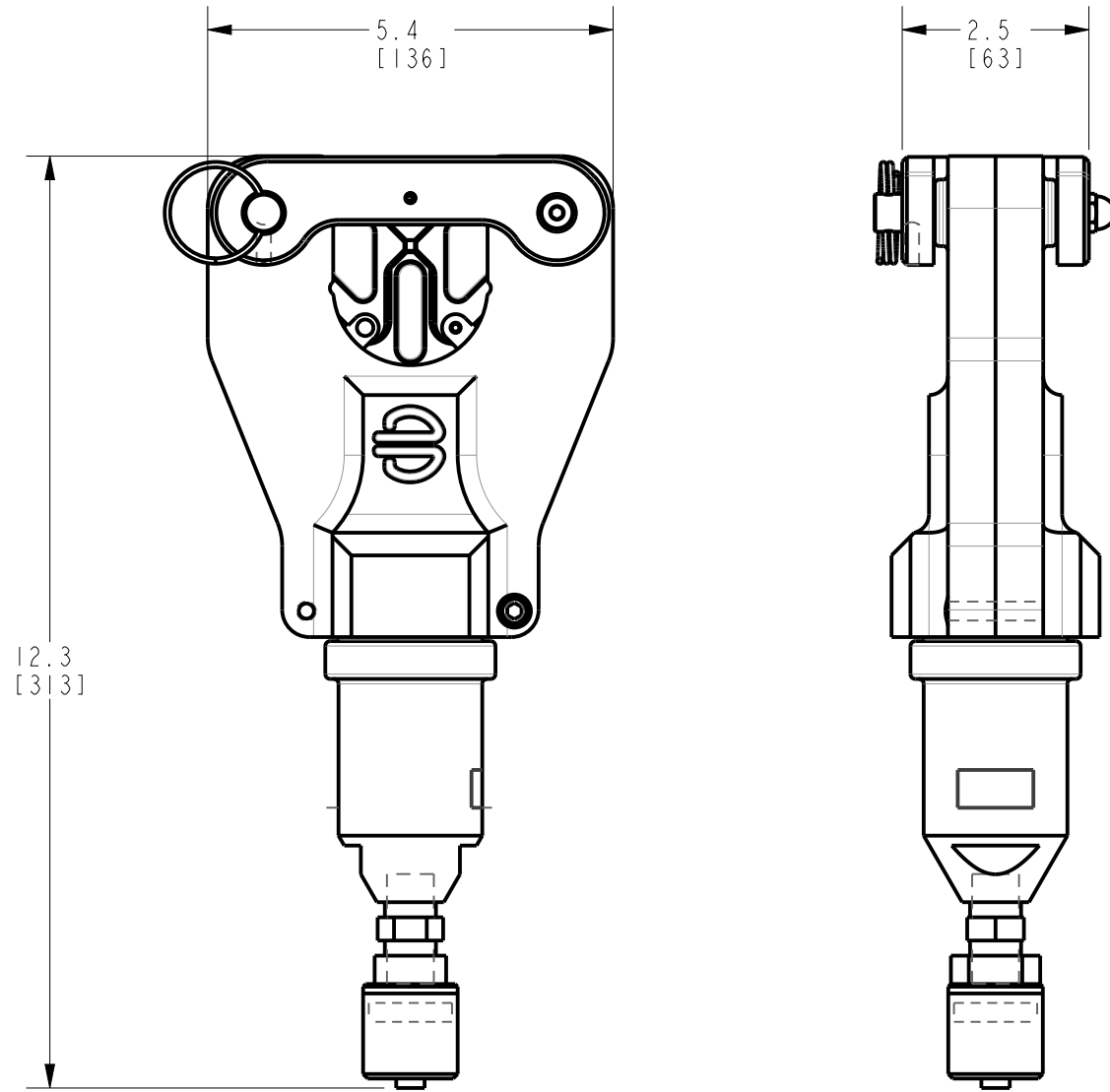

SPECIFICATIONS - TOOL	
Output Force:	6 TONS (5.4 METRIC TONS)
Weight:	8.5 lbs. (3.86 kg)
Head Width:	5.4" (136 mm)
Operating Pressure:	10,000 psi (68.9 MPa)
Overall Length:	12.3" (313 mm)

### FEATURES AND BENEFITS

Features	Benefits
- Flip latch head	- Provides easy tool removal from continuous conductors.
- Dieless system	- Eliminates the need to purchase and maintain dies.
- Rotational head	- Versatile tool head positioning, allows user access into tight areas with ease.

TO ORDER BURNDY® PRODUCTS CALL  
 UNITED STATES:  
 1-800-346-4175 (LONDONDERRY, NH)  
 CANADA:  
 1-800-361-6975 (QUEBEC)  
 1-800-387-6487 (ALL OTHER PROVINCES)  
 FOR PRODUCT INFO: <http://www.burndy.com>

DIELESS HYPRESS 4 POINT REMOTE TOOL				
ITEM NO: 50111426				
CAT. NO: Y81K2MBH				
DRAWN BY:	BAUGER	07/14/21		
CHECKER:	LBROWN	07/14/21		
DSN APPVL:	LBROWN	07/14/21		
MFG APPVL:	LDESMARIS	07/14/21		
QA APPVL:	GREDFIELD	07/14/21		
MKT APPVL:	MGUARRERA	07/14/21	SCALE: 2:5	
PROD FAM:	--		DRAWING NO	REV
PROJECT #:	--	SIZE	50123581	A
DOCUMENT TYPE:	--	B	SHEET 1 OF 1	
REL LEVEL:	Released			

REV: CREO 05/20/21