

HIW716MAG

The new BURNDY® low pressure hydraulic impact wrench MAG Series (Machined Aluminum, Gerotor) is an industrial grade impact wrench designed for drilling holes and fastening hardware in the Utility market. The body of this wrench is made from aircraft grade extruded 6061-T6 Aluminum while the forged handle is made from 7075-T6 aluminum. All internal porting is accomplished through CNC machining for precision, reliability and increased repeatable performance. The wrench balances well in a gloved hand while the handle, grip and trigger have been ergonomically designed for ease of operation. The wrench incorporates a proven gerotor motor for long life and greater efficiency over gear type motors.

BENEFITS

Reliability

- Aircraft grade 7075-T6 extruded Aluminum body and forged handle for added strength
- CNC machining produces tighter tolerances contributing to increased efficiency, repeatability and flow optimization
- Machined steel sleeve and hardened spool increase wrench efficiency by preventing hydraulic fluid "blow by".
- Frictionless gerotor motor design offers exceptional life and greater efficiency
- Specialized urethane shaft seals for extended life
- BURNDY® 5-year limited warranty

Ergonomic Design

- Injection molded replaceable grips
 - "Non-slip" contoured comfort design
 - Isolation from system heat build-up
- Balanced weight in assembled configuration
- Glove-sized handle and ergonomically designed activation trigger for better grip
- Reduced "handle-to-trigger" distance for ease of activation and feathering

Performance

- Over 550 ft-lbs of torque
- 7/16" tri-ball quick chuck for ease of use and strong retention of fasteners/bits
- "On-the-go" FORWARD and REVERSE selector
- Reverse flow protection to prevent reverse hook-ups
- Dual spool selector for Open and Closed Center use

Repairability

- Cartridge style valves eliminate "wear" to internal body of wrench reducing material repair cost and labor.
- Easily replaceable shaft seal design

For Use With: Utility pole hardware & Auger drill bits

Specifications

Chuck Type: 7/16" Quick Chuck
 Optimal Pressure: 1000 - 2000 PSI
 Flow Range: 4-12 GPM
 Optimal flow Range: 4-8 GPM
 Operation: Open/Closed option
 Motor: Gerotor
 Torque: 550 ft-lbs
 Weight: 7.6 lbs (3.5 kg) (TBD)
 Length: 9.0 in (229 mm)
 Height: 9.6 in (243 mm)
 Width: 3.6 in (91 mm)
 Tool Ports: #6 SAE O-ring (F)

KIT CATALOG NO.	DESCRIPTION
HIW716MAG	WRENCH ONLY
HIW716MAGTGKIT	TRIGGER GUARD WITH HARDWARE
HIW716MAGKIT1	WRENCH WITH FLAT FACE COUPLERS
HIW716MAGKIT2	WRENCH WITH SWIVELS, 8' NCR HOSE AND FLAT FACE COUPLERS
HIW716MAGKIT3	WRENCH WITH SWIVELS, 10' NCR HOSE AND FLAT FACE COUPLERS
HIW716MAGKIT4	WRENCH WITH FLAT FACE COUPLERS AND TRIGGER GUARD
HIW716MAGKIT5	WRENCH WITH FLAT FACE COUPLERS, TRIGGER GUARD AND HANDLE
HIW716MAGKIT6	WRENCH WITH LIFTING EYE
HIW716MAGTGKIT2	WRENCH WITH TRIGGER GUARD, HARDWARE, SWIVELS, 8' NCR HOSE AND FLAT FACE COUPLERS
OTHER KITS AVAILABLE CONTACT BURNDY® SALES REPRESENTATIVE FOR MORE INFORMATION	

REV.	DATE	DESCRIPTION	ECO	BY	C.H.K.
G	05/13/2015 00:00:00 AM	FOCUS REQUEST FPN1505028	40231	AS	MB

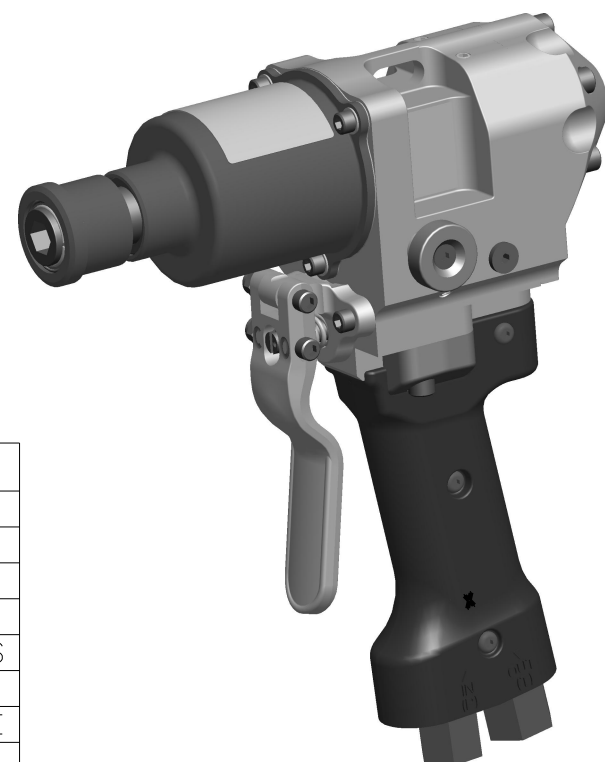
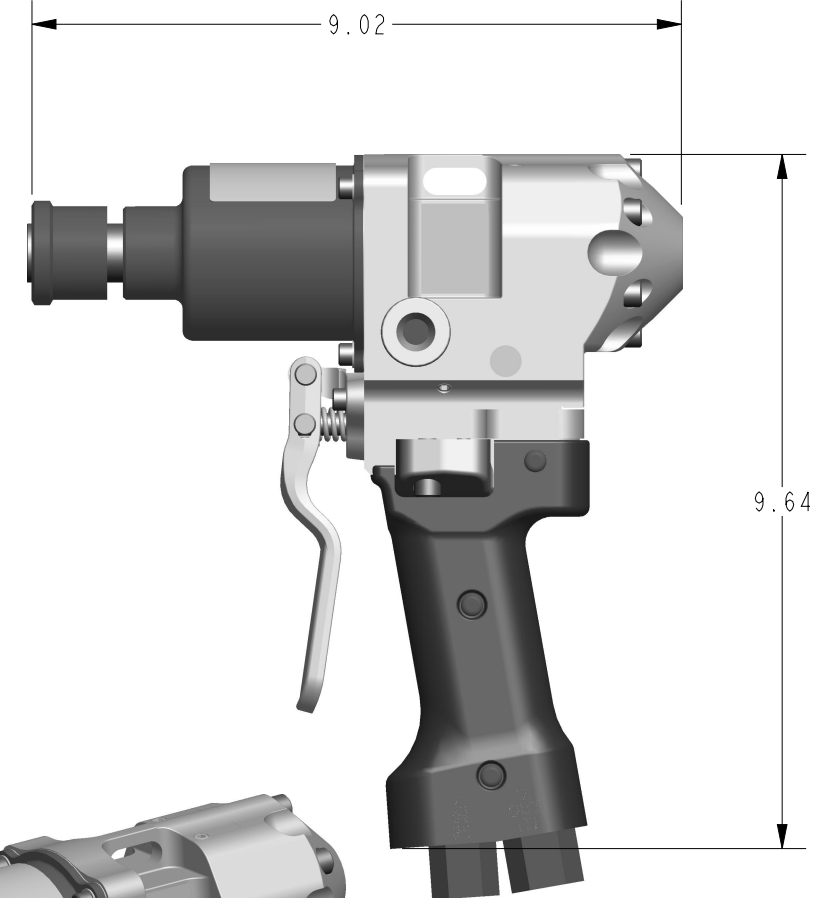
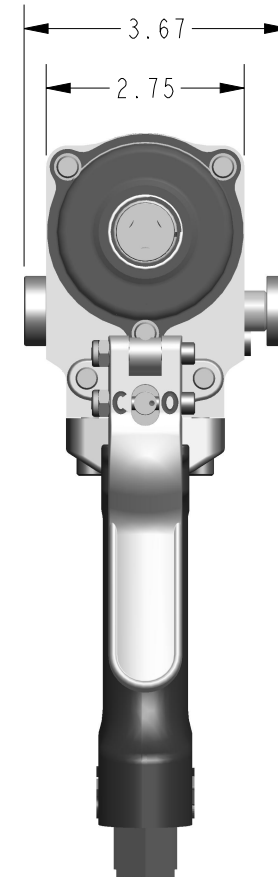

REV: PE0200

TO ORDER BURNDY® PRODUCTS CALL
 UNITED STATES:
 1-800-346-4175 (LONDONDERRY, NH)
 CANADA:
 1-800-361-6975 (QUEBEC)
 1-800-387-6487 (ALL OTHER PROVINCES)
 FOR PRODUCT INFO: <http://www.burndy.com>

HIW716MAG IMPACT WRENCH	
ITEM NO: N/A	CAT. NO: HIW716MAG
DRAWN BY: T. FAUCHER 10/05/2012	CHECKER: D. OWENS 10/05/2012
DSN APPVL: M. CHIASSON 11/07/2012	MFG APPVL: HOPPS / JOHNS 11/08/2012
QA APPVL: J. BRODEUR 11/12/2012	MKT APPVL: D. OWENS 11/07/2012
PROD FAM: TOOLS, HYDRAULIC	DRAWING NO: 50002725
PROJECT #: 14245	SIZE: B
DOCUMENT TYPE: Sales	REV: G
REL LEVEL: Released	SHEET 1 OF 1

