

REV.	DATE	DESCRIPTION	ECO	BY	C'H'K.
A	2001-01-01 12:00:00 EST	CREATE SALES DRAWING	25061	RG	JG

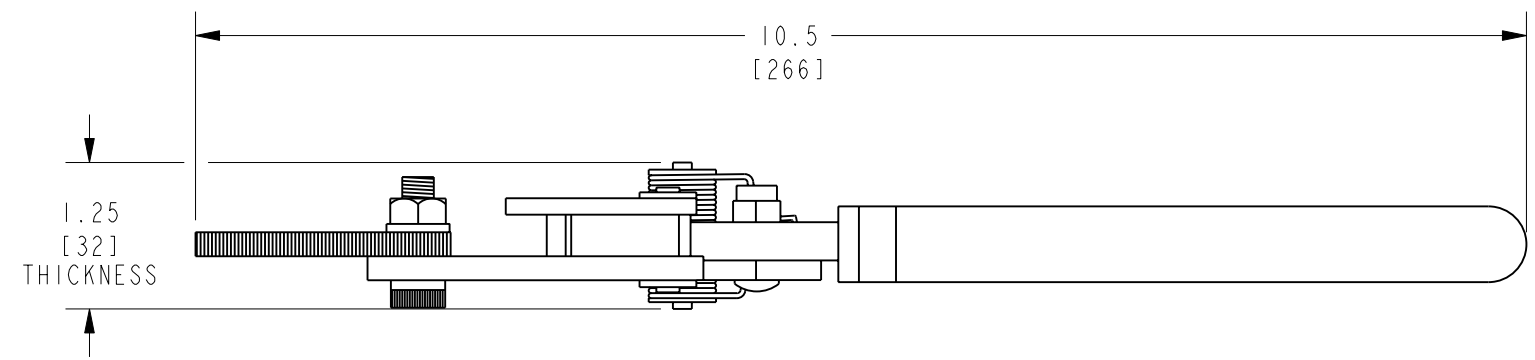
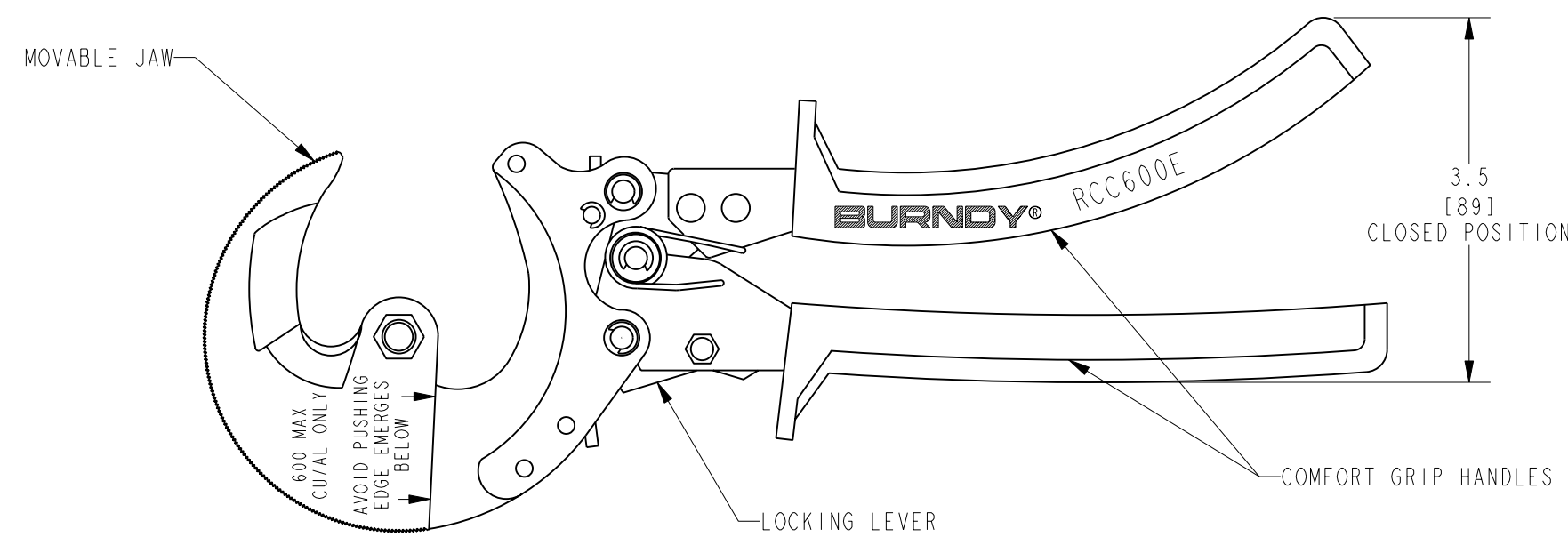

CUTTING CAPACITY
WARNING DO NOT CUT ENERGIZED LINE

COPPER - 600 kcmil (SOFT DRAWN)
ALUMINUM - 600 kcmil
MAX. INSULATION DIA. - 1.05 [27]

NOTES:

- MATERIAL: BLADES: HIGH STRENGTH STEEL
FRAME: HIGH STRENGTH STEEL
HANDLES: ANTI-SLIP RUBBER OVER HIGH STRENGTH STEEL
- WEIGHT: 1.2 LB [0.5 KG]
- RATCHET MECHANISM INCLUDES EMERGENCY RELEASE FEATURE
- READ AND FOLLOW ALL INSTRUCTIONS AND WARNINGS IN THE OPERATOR'S MANUAL BEFORE USING THIS TOOL.
- NOT FOR USE WITH ACSR CABLE, USE ONLY WITH COPPER AND ALUMINUM CABLE.
- DIMENSIONS IN BRACKETS [] ARE IN MILLIMETERS, ROUNDED TO THE NEAREST MILLIMETER, AND ARE FOR REFERENCE ONLY.

TO ORDER BURNDY® PRODUCTS CALL
UNITED STATES:
1-800-346-4175 (LONDONDERRY, NH)
CANADA:
1-800-361-6975 (QUEBEC)
1-800-387-6487 (ALL OTHER PROVINCES)
FOR PRODUCT INFO: <http://www.burndy.com>

RATCHET CABLE CUTTER		SCALE: NTS
ITEM NO: 10102012		
CAT. NO: RCC600E		
DRAWN BY: C. RAJEEV	7/7/11	BURNDY
CHECKER: P. WASON	7/11/11	
DSN APPVL: P. WASON	7/11/11	
MFG APPVL: --	--	
QA APPVL: J. BRODEUR	7/12/11	
MKT APPVL: D. OWENS	7/11/11	
PROD FAM: INSTALLATION TOOL & PARTS	SIZE	DRAWING NO
PROJECT #: --	B	30017058
DOCUMENT TYPE: Sales		SHEET 1 OF 1
REL LEVEL: Released		A

REV: PE0200