

REV.	DATE	DESCRIPTION	ECO	BY	C'H'K.
A	09/10/2014 00:00:00 AM	DRAWING RELEASED	34934	TRF	LNB

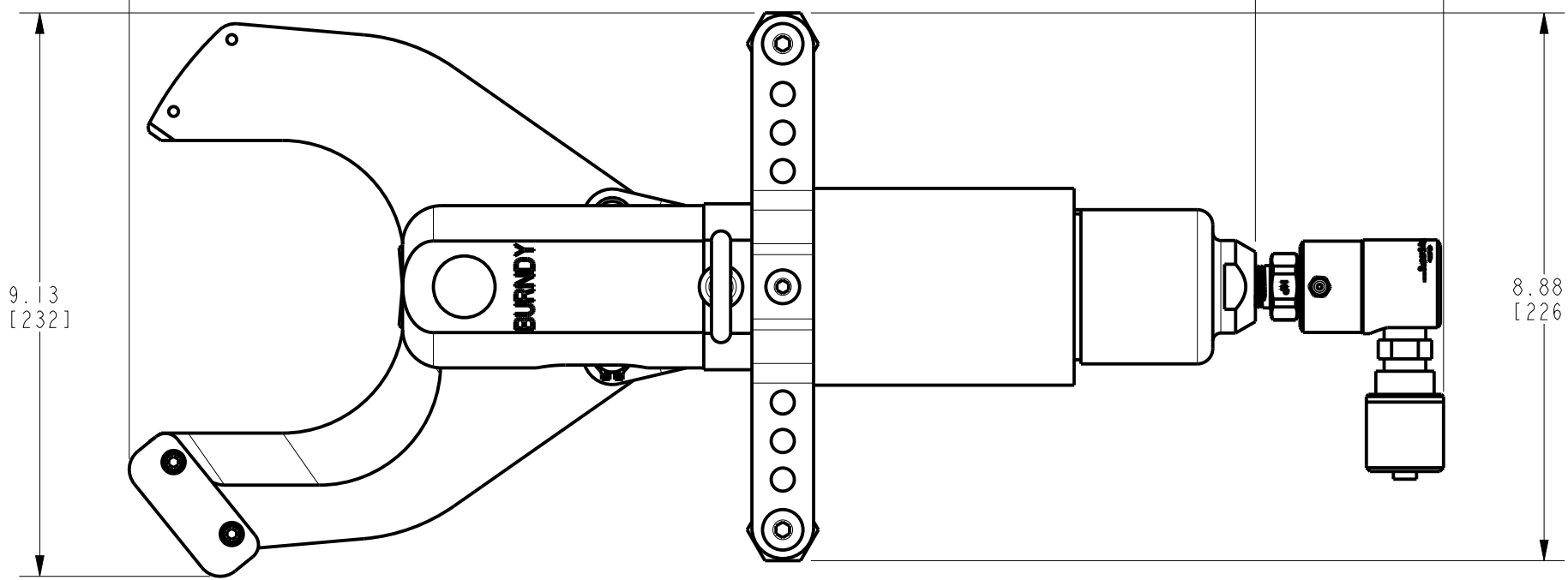
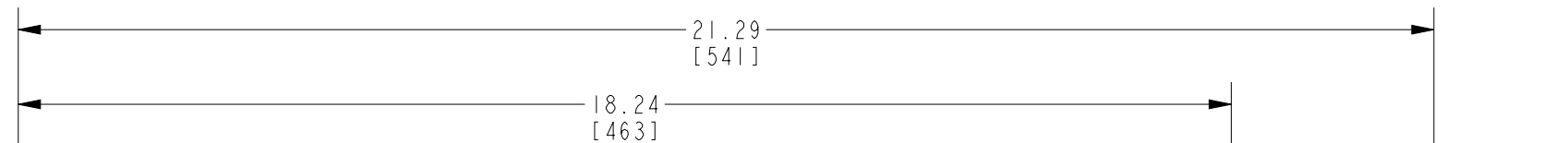
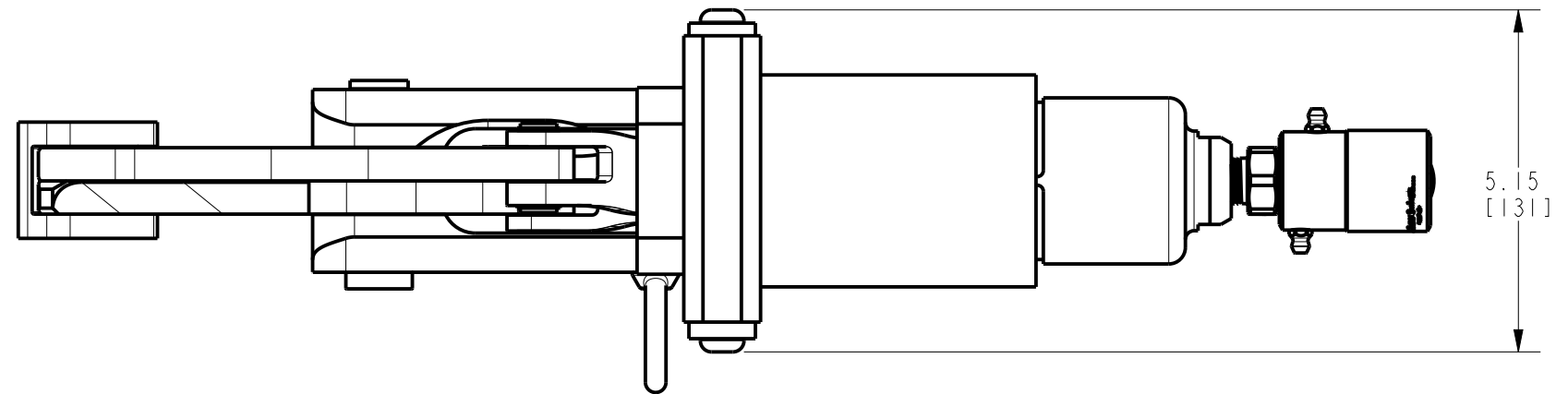
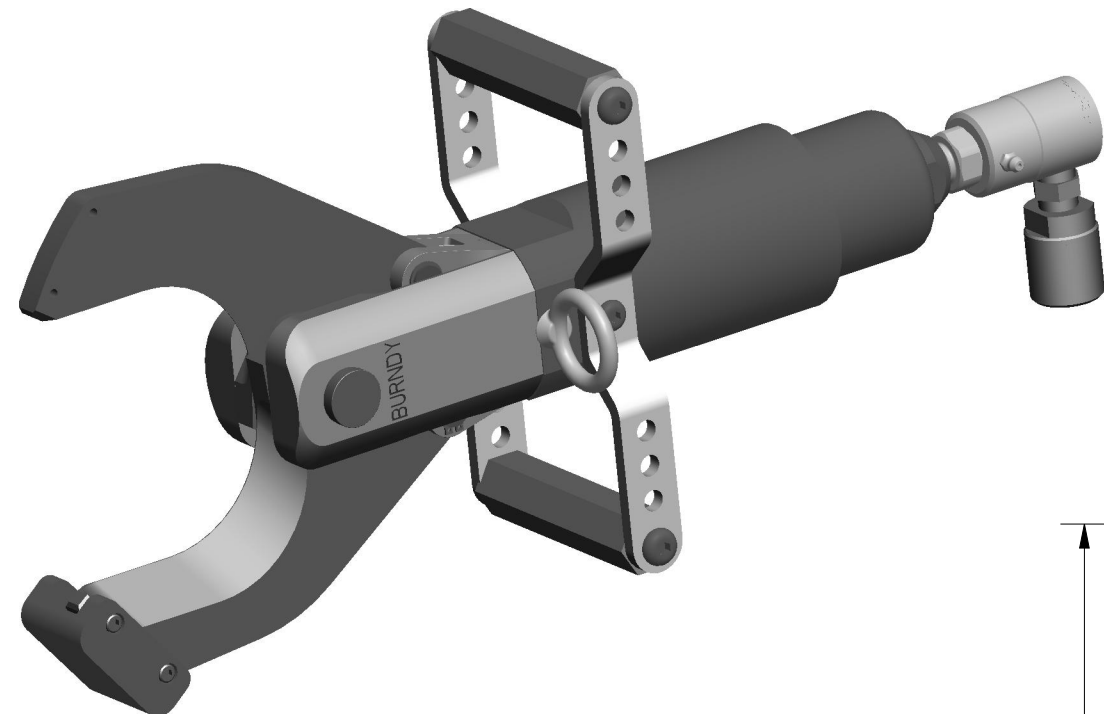

FEATURES AND BENEFITS

- HARDENED STEEL BLADES OFFER RELIABLE, LONG TERM USE.
- WIDE OPENING ACCOMODATES 4.0" STRANDED COPPER AND ALUMINUM CABLES.
- ERGONOMIC STEEL HANDLE ALSO SERVES AS A "BASE" FOR EASE OF CUTTING.
- HEAD ROTATES 355° FOR EASE OF USE.
- 5/16-18 LIFTING ASSIST THREADED HOLE
- SCISSOR-ACTION CUTTING JAWS ENABLE OPERATOR TO PICK UP CABLE FOR BETTER POSITIONING.
- RIGHT ANGLE SWIVEL HOSE CONNECTION ALLOWS FOR TOOL USE IN TIGHT SPACES.

NOTES:

- DIMENSIONS IN BRACKETS [] ARE IN MILLIMETERS, ROUNDED TO THE NEAREST MILLIMETER AND ARE FOR REFERENCE ONLY.
- WEIGHT = 19.9 LBS (8.6 KG)

TO ORDER BURNDY® PRODUCTS CALL		CUTTER, RHCC4CUAL	
UNITED STATES:		ITEM NO: 50024759	
1-800-346-4175 (LONDONDERRY, NH)		CAT. NO: RHCC4CUAL	
CANADA:		DRAWN BY: T. FAUCHER 02/10/2014	
1-800-361-6975 (QUEBEC)		CHECKER: L. BROWN 02/11/2014	
1-800-387-6487 (ALL OTHER PROVINCES)		DSN APPVL: L. BROWN 09/05/2014	
FOR PRODUCT INFO: http://www.burndy.com		MFG APPVL: S. HOPPS 09/04/2014	
		QA APPVL: C. LINDQUIST 09/09/2014	
		MKT APPVL: M. RZASA 09/08/2014	
		SCALE: 3:8	
		PROD FAM: TOOLS, HYDRAULIC	
		PROJECT #: 14560	
		SIZE	
		DRAWING NO	
		REV	
		PROJECT #: 14560	
		DOCUMENT TYPE: Sales	
		REL LEVEL: Released	
		50024761	
		SHEET 1 OF 1	
		A	

REV: PE0200