

*** Y46LWSBH BILL OF MATERIAL ***

| PT NO. | CATALOG NO. | QTY | DESCRIPTION |
|--------|-------------|-----|----------------|
| 1 | Y46LWSBHOM1 | 1 | SOMI, Y46LWSBH |
| 2 | PT20443801 | 1 | WARRANTY CARD |
| 3 | PT10054094 | 1 | CARRYING BAG |

*** Y46LWBH BILL OF MATERIAL ***

| PT NO. | CATALOG NO. | QTY | DESCRIPTION |
|--------|-------------|-----|---------------|
| 1 | Y46LWBHOM1 | 1 | SOMI, Y46LWBH |
| 2 | PT20443801 | 1 | WARRANTY CARD |
| 3 | PT10054094 | 1 | CARRYING BAG |

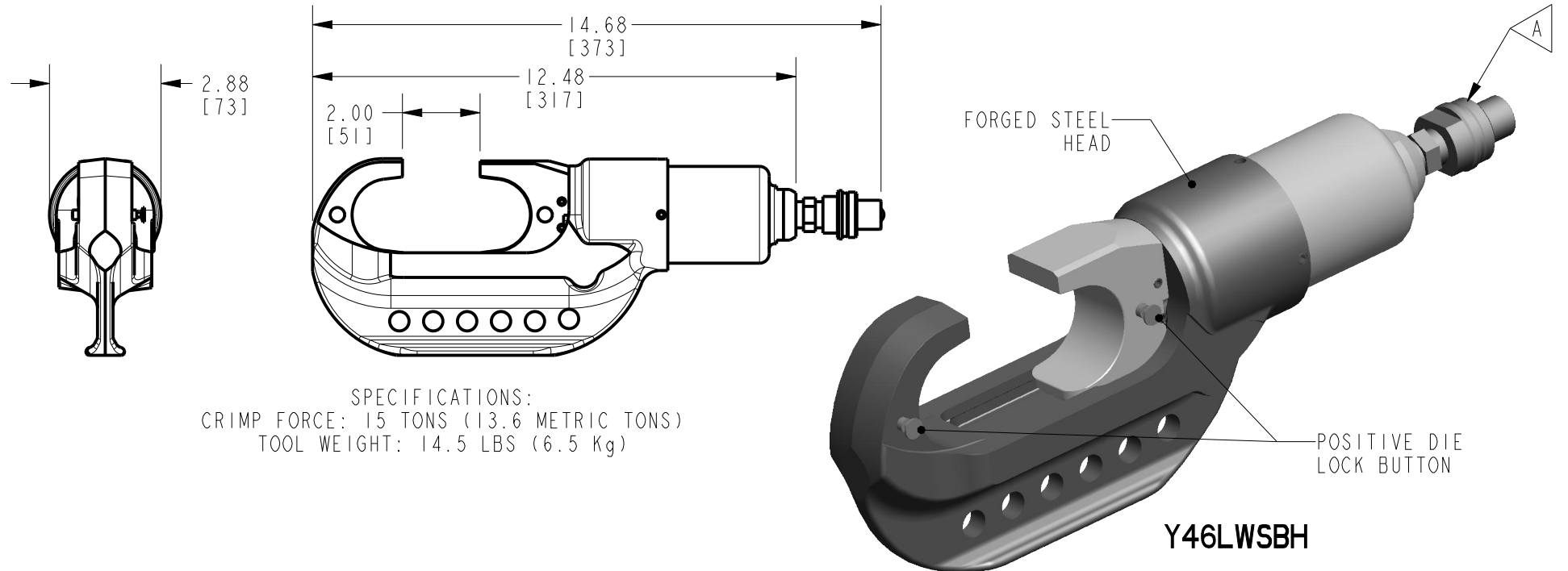

SPECIFICATIONS:
 CRIMP FORCE: 15 TONS (13.6 METRIC TONS)
 TOOL WEIGHT: 14.5 LBS (6.5 Kg)

NOTES:

1. OPERATING PRESSURE: 10,000PSI (69,000 kPa)
2. ACCEPTS STANDARD "P" DIES. ALSO ACCEPTS STANDARD "U" DIES WHEN USED WITH "PUADP-1" ADAPTER (SEE NOTE 3).
3. ACCESSORIES:

| CATALOG NO. | DESCRIPTION |
|-------------|--|
| P15K | CABLE CUTTER DIE (MAX CABLE DIA 1.20 IN [30.5 mm]) |
| PUADP-1 | "U" DIE ADAPTER |
| PT10128 | UNIVERSAL HOT STICK ADAPTER |

4. SUPPLIED WITH CARRY BAG PT10054094.

FEATURES AND BENEFITS:

- REFINED HYDRAULIC SYSTEM FOR SUPERIOR PERFORMANCE, SPEED AND RELIABILITY.
- STATE OF THE ART CRIMPING HEAD DESIGN, 350° ROTATION LETS THE USER GET IN TIGHT AREAS EASIER.
- ALLOWS USE OF STANDARD BURNDY® DIES ALREADY IN USE.

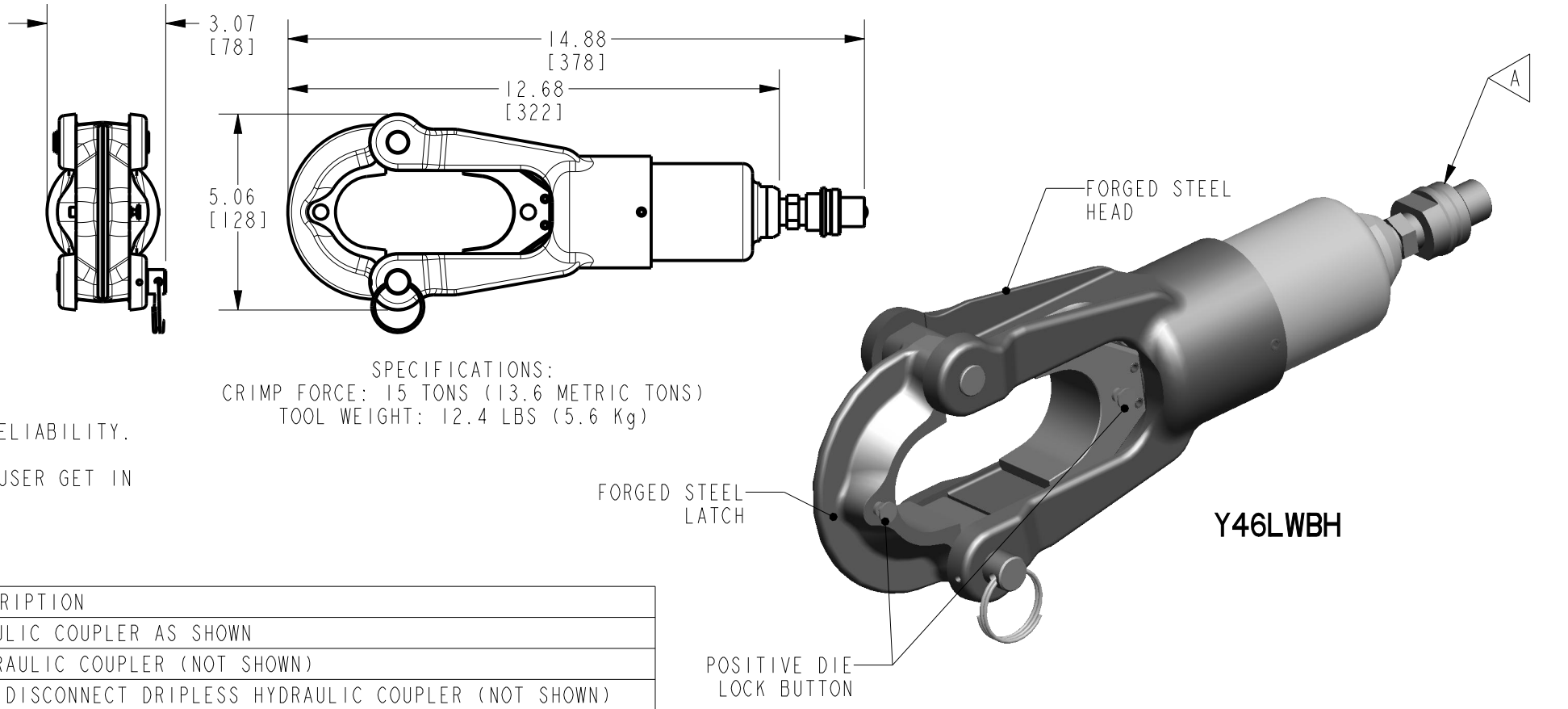

SPECIFICATIONS:
 CRIMP FORCE: 15 TONS (13.6 METRIC TONS)
 TOOL WEIGHT: 12.4 LBS (5.6 Kg)

| A | CATALOG NUMBER | DESCRIPTION |
|---|----------------|---|
| | Y46LWSBH | SUPPLIED WITH A 10,000PSI [69,000 kPa] MALE HYDRAULIC COUPLER AS SHOWN |
| | Y46LWSBHF | SUPPLIED WITH A 10,000PSI [69,000 kPa] FEMALE HYDRAULIC COUPLER (NOT SHOWN) |
| | Y46LWSBHQD | SUPPLIED WITH A 10,000PSI [69,000 kPa] MALE QUICK DISCONNECT DRIPLESS HYDRAULIC COUPLER (NOT SHOWN) |
| | Y46LWSBHQDF | SUPPLIED WITH A 10,000PSI [69,000 kPa] FEMALE QUICK DISCONNECT DRIPLESS HYDRAULIC COUPLER (NOT SHOWN) |
| | Y46LWBH | SUPPLIED WITH A 10,000PSI [69,000 kPa] MALE HYDRAULIC COUPLER AS SHOWN |
| | Y46LWBHF | SUPPLIED WITH A 10,000PSI [69,000 kPa] FEMALE HYDRAULIC COUPLER (NOT SHOWN) |
| | Y46LWBHQD | SUPPLIED WITH A 10,000PSI [69,000 kPa] MALE QUICK DISCONNECT DRIPLESS HYDRAULIC COUPLER (NOT SHOWN) |
| | Y46LWBHQDF | SUPPLIED WITH A 10,000PSI [69,000 kPa] FEMALE QUICK DISCONNECT DRIPLESS HYDRAULIC COUPLER (NOT SHOWN) |
| | Y46CLWSBH | COVERED VERSION SUPPLIED WITH A 10,000PSI [69,000 kPa] MALE QUICK DISCONNECT DRIPLESS HYDRAULIC COUPLER (NOT SHOWN) |
| | Y46CLWSBHF | COVERED VERSION SUPPLIED WITH A 10,000PSI [69,000 kPa] FEMALE QUICK DISCONNECT DRIPLESS HYDRAULIC COUPLER (NOT SHOWN) |

| | | | |
|---|--|----------------------------------|--|
| TO ORDER BURNDY® PRODUCTS CALL | | HYPRESS TOOL, Y46LWSBH & Y46LWBH | |
| UNITED STATES: 1-800-346-4175 (LONDONDERRY, NH) | | ITEM NO: N/A | |
| CANADA: 1-800-361-6975 (QUEBEC) 1-800-387-6487 (ALL OTHER PROVINCES) | | CAT. NO: SEE TABLE A | |
| FOR PRODUCT INFO: http://www.burndy.com | | SCALE: 1:1 | |
| | | DRAWING NO | |
| | | REV | |
| | | 50024880 | |
| | | D | |
| | | SHEET 1 OF 1 | |

REV: PE0200