

REV.	DATE	DESCRIPTION	ECO	BY	C.H.K.
D	12/08/2016 00:00:00 AM	DRAWING RELEASED	44912	TRF	MAC

\*\*\* Y46LWSBH BILL OF MATERIAL \*\*\*

PT NO.	CATALOG NO.	QTY	DESCRIPTION
1	Y46LWSBHOM1	1	SOMI, Y46LWSBH
2	PT20443801	1	WARRANTY CARD
3	PT10054094	1	CARRYING BAG

\*\*\* Y46LWBH BILL OF MATERIAL \*\*\*

PT NO.	CATALOG NO.	QTY	DESCRIPTION
1	Y46LWBHOM1	1	SOMI, Y46LWBH
2	PT20443801	1	WARRANTY CARD
3	PT10054094	1	CARRYING BAG

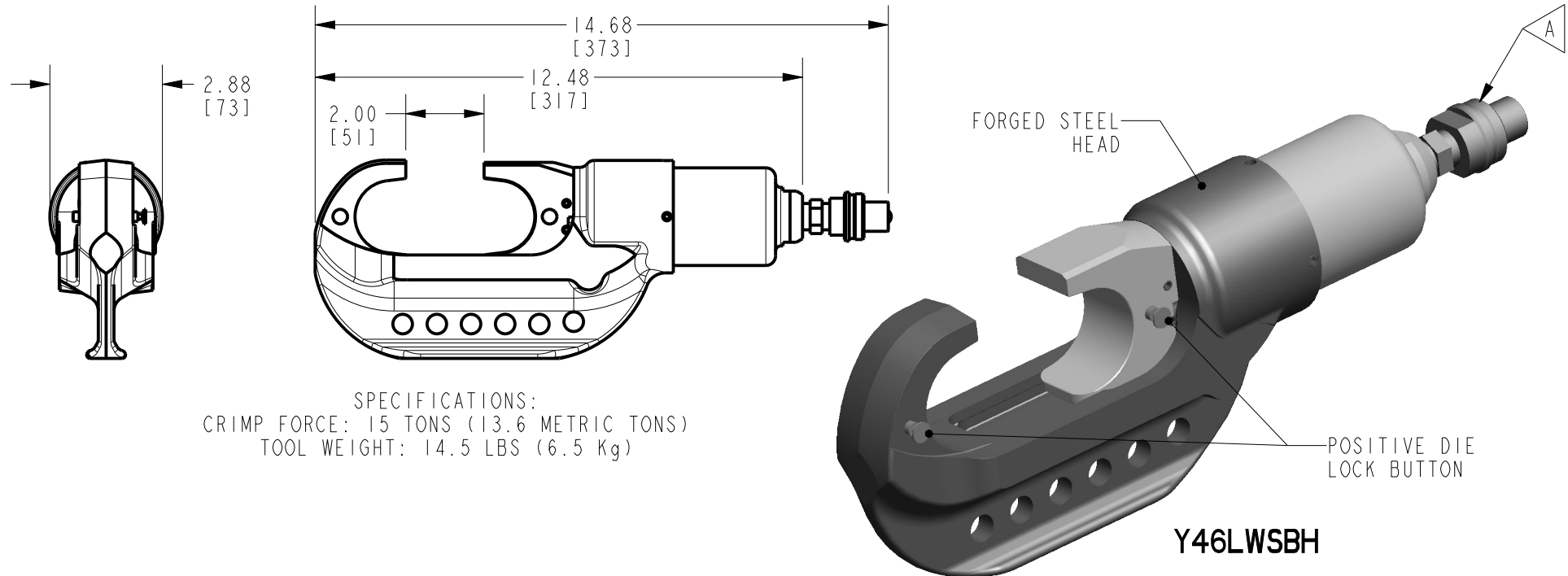

SPECIFICATIONS:  
 CRIMP FORCE: 15 TONS (13.6 METRIC TONS)  
 TOOL WEIGHT: 14.5 LBS (6.5 Kg)

NOTES:

1. OPERATING PRESSURE: 10,000PSI (69,000 kPa)
2. ACCEPTS STANDARD "P" DIES. ALSO ACCEPTS STANDARD "U" DIES WHEN USED WITH "PUADP-1" ADAPTER (SEE NOTE 3).
3. ACCESSORIES:

CATALOG NO.	DESCRIPTION
P15K	CABLE CUTTER DIE (MAX CABLE DIA 1.20 IN [30.5 mm])
PUADP-1	"U" DIE ADAPTER
PT10128	UNIVERSAL HOT STICK ADAPTER

4. SUPPLIED WITH CARRY BAG PT10054094.

FEATURES AND BENEFITS:

- REFINED HYDRAULIC SYSTEM FOR SUPERIOR PERFORMANCE, SPEED AND RELIABILITY.
- STATE OF THE ART CRIMPING HEAD DESIGN, 350° ROTATION LETS THE USER GET IN TIGHT AREAS EASIER.
- ALLOWS USE OF STANDARD BURNDY® DIES ALREADY IN USE.

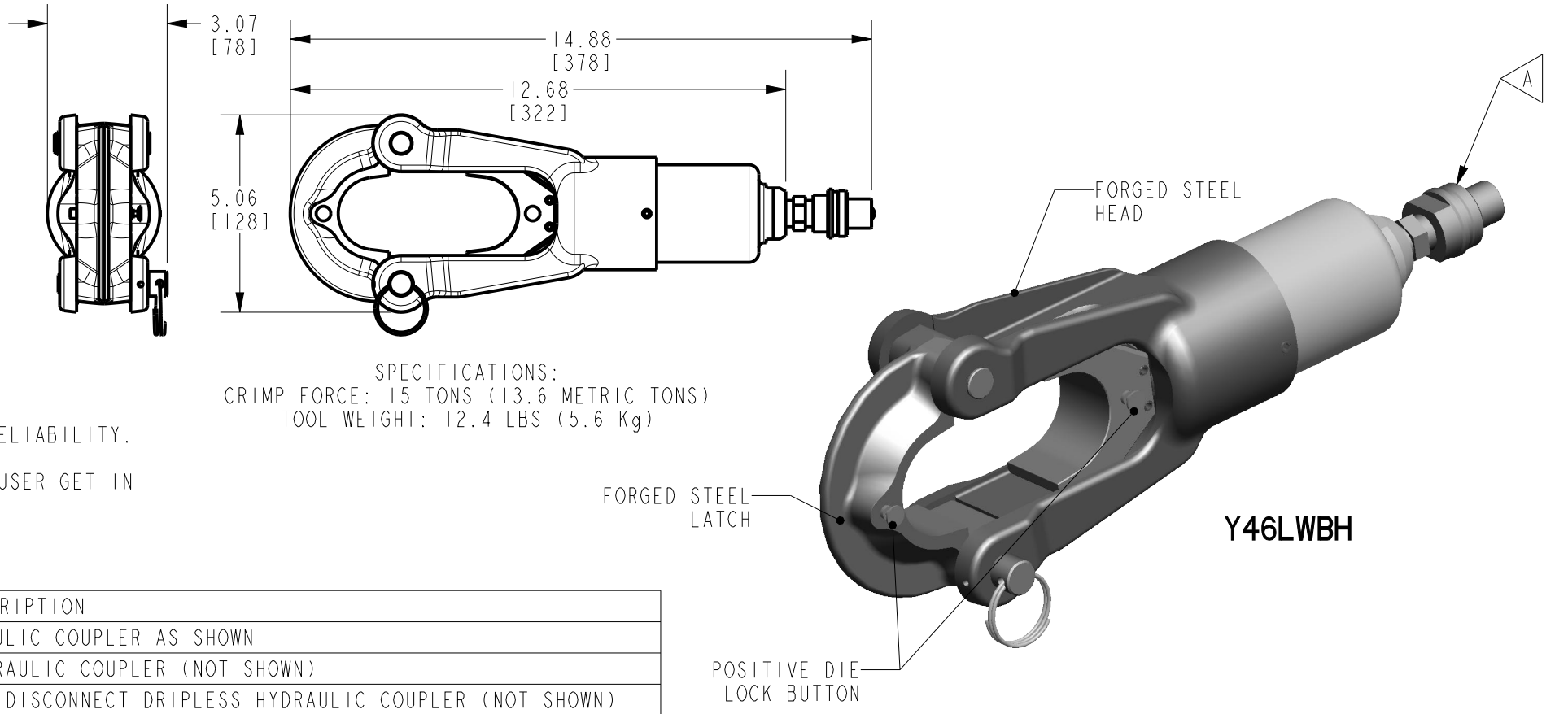

SPECIFICATIONS:  
 CRIMP FORCE: 15 TONS (13.6 METRIC TONS)  
 TOOL WEIGHT: 12.4 LBS (5.6 Kg)

A	CATALOG NUMBER	DESCRIPTION
	Y46LWSBH	SUPPLIED WITH A 10,000PSI [69,000 kPa] MALE HYDRAULIC COUPLER AS SHOWN
	Y46LWSBHF	SUPPLIED WITH A 10,000PSI [69,000 kPa] FEMALE HYDRAULIC COUPLER (NOT SHOWN)
	Y46LWSBHQD	SUPPLIED WITH A 10,000PSI [69,000 kPa] MALE QUICK DISCONNECT DRIPLESS HYDRAULIC COUPLER (NOT SHOWN)
	Y46LWSBHQDF	SUPPLIED WITH A 10,000PSI [69,000 kPa] FEMALE QUICK DISCONNECT DRIPLESS HYDRAULIC COUPLER (NOT SHOWN)
	Y46LWBH	SUPPLIED WITH A 10,000PSI [69,000 kPa] MALE HYDRAULIC COUPLER AS SHOWN
	Y46LWBHF	SUPPLIED WITH A 10,000PSI [69,000 kPa] FEMALE HYDRAULIC COUPLER (NOT SHOWN)
	Y46LWBHQD	SUPPLIED WITH A 10,000PSI [69,000 kPa] MALE QUICK DISCONNECT DRIPLESS HYDRAULIC COUPLER (NOT SHOWN)
	Y46LWBHQDF	SUPPLIED WITH A 10,000PSI [69,000 kPa] FEMALE QUICK DISCONNECT DRIPLESS HYDRAULIC COUPLER (NOT SHOWN)
	Y46CLWSBH	COVERED VERSION SUPPLIED WITH A 10,000PSI [69,000 kPa] MALE QUICK DISCONNECT DRIPLESS HYDRAULIC COUPLER (NOT SHOWN)
	Y46CLWSBHF	COVERED VERSION SUPPLIED WITH A 10,000PSI [69,000 kPa] FEMALE QUICK DISCONNECT DRIPLESS HYDRAULIC COUPLER (NOT SHOWN)

TO ORDER BURNDY® PRODUCTS CALL  
 UNITED STATES:  
 1-800-346-4175 (LONDONDERRY, NH)  
 CANADA:  
 1-800-361-6975 (QUEBEC)  
 1-800-387-6487 (ALL OTHER PROVINCES)  
 FOR PRODUCT INFO: <http://www.burndy.com>

HYPRESS TOOL, Y46LWSBH & Y46LWBH	
ITEM NO: N/A	CAT. NO: SEE TABLE A
DRAWN BY: T. FAUCHER 06/12/2014	CHECKER: M. CHIASSON 06/12/2014
DSN APPVL: M. CHIASSON 07/02/2014	MFG APPVL: S. GONYAW 07/03/2014
QA APPVL: C. LINDQUIST 07/09/2014	MKT APPVL: M. RZASA 07/02/2014
PROD FAM: TOOLS, HYDRAULIC	SCALE: 1:1
PROJECT #: --	DRAWING NO: 50024880
DOCUMENT TYPE: --	REV: D
REL LEVEL: Released	SHEET 1 OF 1

REV: PE0200