

Column Type Air Micrometer

CAG3000

Instruction Manual



Thank you for your purchase of the
 CAG3000

- In order to use this product safely and correctly, please read through the manual thoroughly and understand it very well.
- After reading the manual, please have it readily available for future use.

Please read before using the device

- Please follow all 『Safety Precautions』 to avoid fire, electric shock and other related injuries.
- After reading the manual, please ensure to store it in an accessible area.
- In case the unit is used by other persons, give the unit together with this manual.
- This device is manufactured under Japan laws so it is for domestic use only. In case this device is used overseas, please observe the safety laws implemented by the country.
- Warranty coverage shall be based on TOSOK's warranty policies.
 - Even if the device is under warranty, if the cause of the breakdown is due to the negligence of the user, the repair cost shall be charged to the customer.
 - In case the device becomes defective due to modifications made by customer, there shall be cases that TOSOK can refuse to accept the repair.
 - The repair is based upon receipt of the defective unit. Even if the device is under warranty, in case the repair will need on site visit, the cost of the trip shall be charged to the customer.

Table of Contents

1 .	Safety Precautions	..	2
2 .	Overview	..	3
	▪ Specifications	..	3
	▪ Model	..	4
	▪ Standard Accessories	..	4
3 .	Names and Functions of Controls and Parts	..	5
4 .	Installation	..	7
5 .	Power "ON" / "OFF"	..	7
6 .	Operating Procedure	..	8
7 .	Setting Procedure	..	10
	▪ Program Change	..	10
	▪ Setting values	..	10
8 .	Adjustment	..	13
	▪ Standard Pressure	..	13
	▪ ZERO/MAG	..	14
	▪ Calibration	..	15
9 .	RS232C Output	..	16
10 .	External Switch Input	..	17
11 .	Appendix	..	18
	▪ Setting Procedure Summary	..	18

1 . Safety Precautions

Before using this device, make sure you read the safety precautions thoroughly. Please comply with the directions and use the device properly.

Warning display

Important notice for usage :

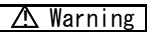
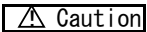
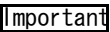
 **Warning**  **Caution**  **Important**

is classified by the above symbols.

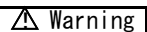
 **Warning** ● May cause death or severe injuries if used improperly.

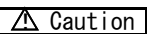
 **Caution** ● May cause severe injuries if used improperly.

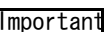
 **Important** ● May result to damage to the device if used improperly.

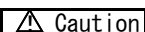
For those items marked with  **Caution** depending on the conditions, it can still result in serious situations. All safety related important details are written here so please follow them by all means.

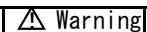
 **Warning**

- 1 . Do not modify or disassemble the device. Modification or disassembly of the device by unqualified personnel can cause malfunction and possible fire, electric shock and injuries.
- 2 . Do not let an unqualified personnel repair the device. Repair by an unqualified personnel can cause malfunction and possible fire, electric shock and injuries.
- 3 . Please supply the correct power rating as stated in the instruction manual. Any power supply that is out of spec can cause fire and electric shock. The main unit operates on 5 to 7 VDC. The device is provided with AC adaptor (standard accessory) that runs at 85~264VAC.
- 4 . During air connection, installation or movement of the device, please remove the electric cable from the main unit. Doing these with the electric cables still plugged in can cause electric shock.
- 5 . Connect the device to a ground line. No proper grounding can cause electric shock when device breakdown or short circuit.
- 6 . Check the power line is securely plugged in the power source. Power lines that are loosely plugged-in can cause fire and electric shock.
- 7 . Do not use damaged cables or plugs. Damaged cables or plugs are possible causes of fire and electric shock.
- 8 . Power cable must be checked periodically. Do not use damaged cables anymore. Damaged cables are possible causes of fire and electric shock.
- 9 . Check extension cord periodically. Do not use if it is damaged already. Damaged extension cords are possible causes of fire and electric shock.
- 10 . Before plugging in the power line to the power source, check if the 「Power SW」 is turned "OFF". If the 「Power SW」 is turned "ON" before plugging, it can cause electric shock.
- 11 . When unplugging the power cable, do not pull the cable out from the power source. Pulling the cable from the power source can damage it and cause fire and electric shock.
- 12 . When power cables are placed near places that are heated, oily or cornered, do not let it be damaged. If the power cable is damaged, it can cause fire and electric shock.
- 13 . Clean dirt on power cable periodically. If the dirt piles up, it can cause fire.
- 14 . During maintenance/repair of the device, disconnect the power cable. If the power cable is left plugged in during maintenance, it can cause electric shock.
- 15 . In case the device will not be used for long period of time, unplug the power cable from the source. Deterioration can cause fire and electric shock.
- 16 . Do not use the device in humid places or wet environment. This can lead to electrical failure and can cause fire and electric shock.
- 17 . Do not use the device in unstable places. The device can become defective if it is turned over, dropped with great impact. In case the device is turned over or dropped, please contact our company.
- 18 . Do not put objects inside the device. Any objects like conductive materials inserted on the main body's small openings can cause the unit to fail.
- 19 . Do not use benzene or thinner in cleaning the device. It can cause the unit to discolor.

2 . Overview

Specifications

Item	Specifications	Notes
Product name	Column type air micrometer	
Model	CAG3000	
Basic Specifications		
No. of channels	1	
Measurement items	1	
Measurement range[μm]	20 50 100	Preset prior to shipment.
Display range [μm]	16 40 80	Depends on the prescribed range.
Display resolution[μm]	0.2 0.5 1.0	Depends on the measurement range
Error margin [μm]	0.4 1.0 2.0	
Mastering		
MASTER adjustment	Electric type	The air type model will have no ZERO/MAG knobs in the future.
Master Set function	Minimum · Maximum	
Measurement		
Measurement function	Real time	* Option: Peak measurement
Display		
Measured value	101dot BAR LED	
	2" TFT LCD	
Judgement result	BAR LED Color	OK = GREEN, NG = RED
	TFT LCD Color	* Option: Rank display
Setting		
Display	2" TFT LCD	
MENU display language	Chinese, Japanese, English	Can be changed through settings.
No. of programs	10	
Interface (I/F)		
RS232C OUT	1 port	Output meas. value/judgement result
Ext SW (DRY port) IN	4ports (measure, RESET, min, max)	Push button SW/Foot SW connector
Environment condition		
Operating temp [$^{\circ}\text{C}$]	5 - 40	
Air supply [MPa]	0.4 - 0.6	
Flowrate [L/min]	50	
Power [V]	DC 7 - 12	EXT cable adaptor is for AC85-264[V].
Current consumption [A]	2	
Weight [kg]	2.5	

Model

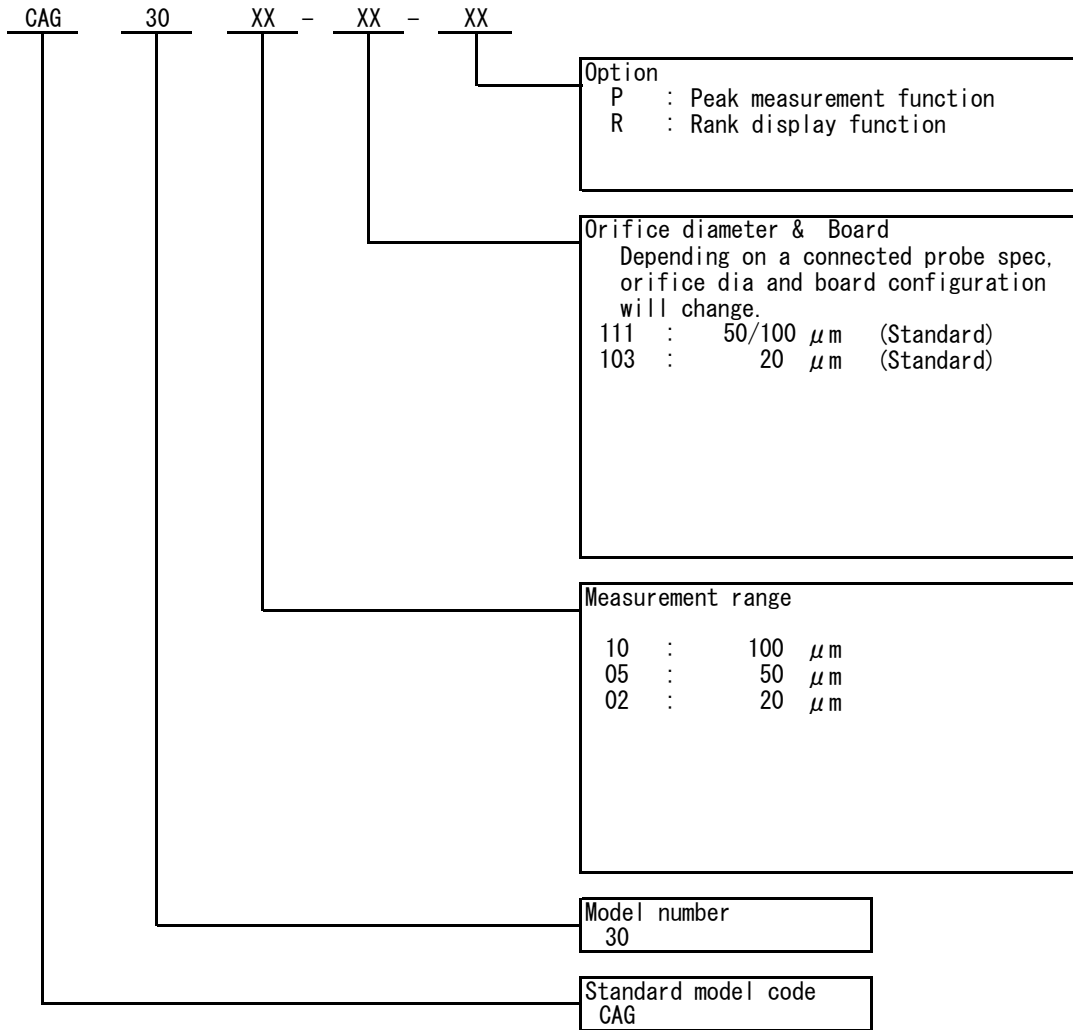

Standard Accessories

- AC adaptor

3 . Names/Functions of each part

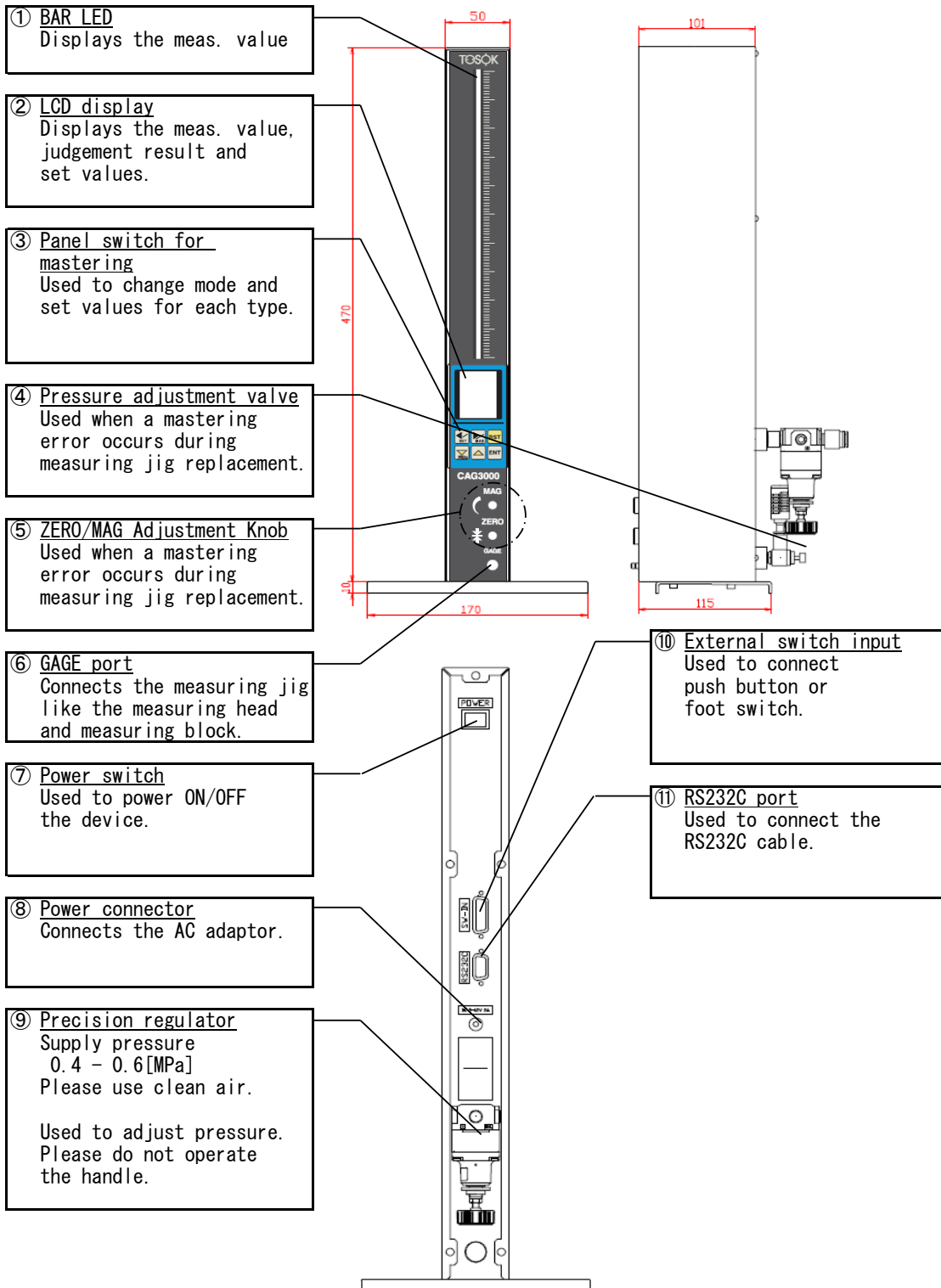

②.LCD display detail

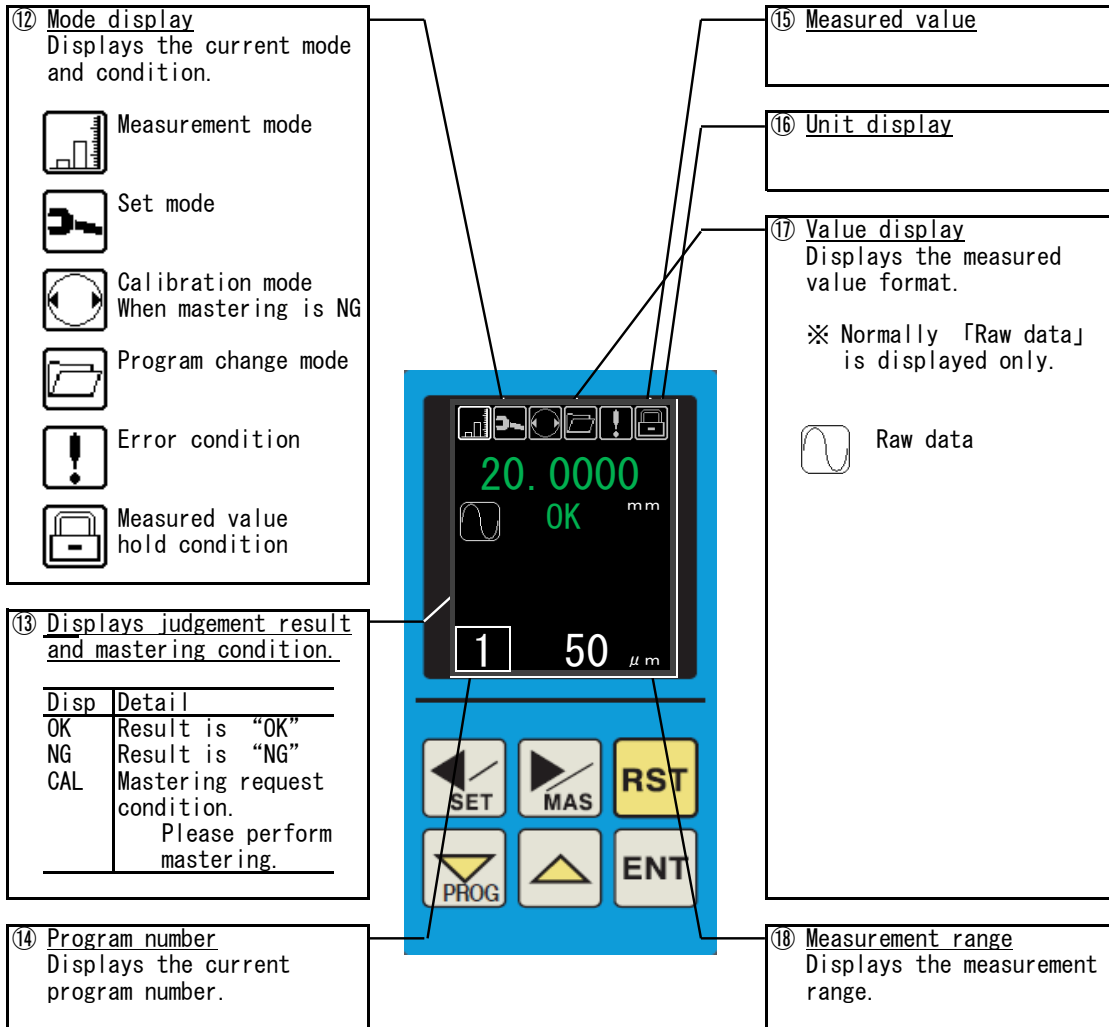

4 . Installation

Installing the device

Important ● Install the device on a stable and level surface with no vibrations.

Set the device on the desired place.

Connect the air hose.

Warning ● Connect the air hose only when power is turned OFF.

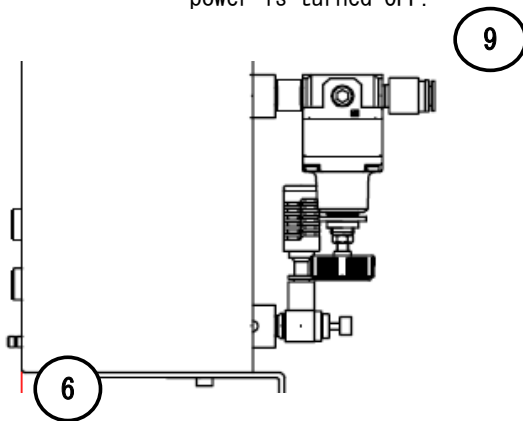

- 1 Turn OFF the 「⑦.Power switch」.
- 2 Connect the air hose of the measuring block to the 「⑥.GAGE port」.
- 3 Connect the air hose from the filter to the 「⑨.Precision regulator」.

Connect the AC adaptor

Please connect the 「AC Adaptor」 following the procedure below.

- 1 Turn "OFF" the 「⑥.Power switch」.
- 2 Unplug the AC adaptor from the power source.
- 3 Connect the AC adaptor to the 「⑨.Power connector」.

5 . Power "ON" "OFF"

Supply the power

- 1 Plug the AC adaptor to the power source.
- 2 Turn "ON" the 「⑦.Power switch」.

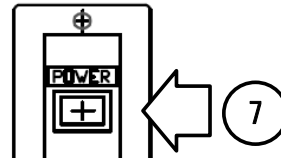

- 3 The opening demo will be shown.



Software version shall be displayed.

Turn the power OFF

- 1 Turn "OFF" the 「⑦.Power switch」.

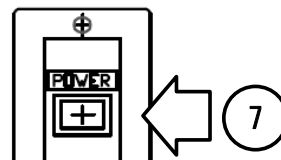

- 2 Unplug the AC adaptor from the power source.

6 . Operating Procedure

Preparations before measurement

Important

- Air micrometer is a comparative measuring device.
The precision cannot be guaranteed if there are dirt, scratch, dent or rust on the master or measurement jig.
- Precision is not guaranteed if measurement jigs made by other companies is connected to the device.
- Air micrometer is weak on water and oil. In case water or oil gets in the device, the following conditions may happen :
 - Precision becomes bad.
 - The displayed value becomes unstable.
 - Different values are displayed for the same measured object.
 By periodically replacing the filter element, the above conditions can be prevented from happening.

We recommend the overhaul of the device if water or oil gets inside the main unit.

- | | |
|---|--|
| 1 | Check the filter condition.
● Is water or oil clogged up? |
| 2 | Check the measure jigs and master.
● Any dirt, scratch, dent or rust? |
| 3 | With compressed air, turn the power "ON". |
| 4 | After the opening demo, 「CAL」 shall be displayed.
Please perform mastering. |



Mastering

Perform calibration by master.

Important

- Mastering must be done on any of the following conditions.
 - Every 2 to 4 hours
 - When power or air supply is turned "ON".
 - When indicated value looks abnormal.

- 5 Press  for more than 2 secs.

Mode display will change to .

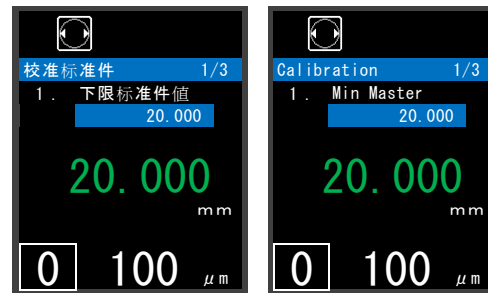

- 6 Set 「Min master」 the measurement jig. Once the indicator stabilizes, press .

- 7 Set 「Max master」 on measurement jig. Once the indicator stabilizes, press . Perform 「Max mastering」.

- 8 Check the display of 「TFT LCD」. 「MAS OK」 Mastering is successful. Proceed to measurement.

「ERR ZERO」
「ERR MAG」 There is error if any of these three appears.
「ERR REV」 Please deal with the cause of the mastering error.

Mastering error processing

If error occurs, please confirm and correct the condition.

- Is the supply pressure correct?
- Was the min master and max master taken by mistake?
- Is there any dirt, scratch, dent or rust on the measure jig or master?
- If none of the above, proceed to 8. Adjustments and perform the task.

Measurement

Measure the work object.

Caution

- During measurement mode, By pressing  for more than 2 secs. the mode will change to Master mode.

In order to maintain the measurement accuracy, perform mastering about every 2 hours.

- 1 Set the work object on the measurement jig.
- 2 The measured value and judgement result shall be displayed. If the color of the 「BAR LED」 is ...
 “green”, value is OK and in range.
 “red”, value is out of range.

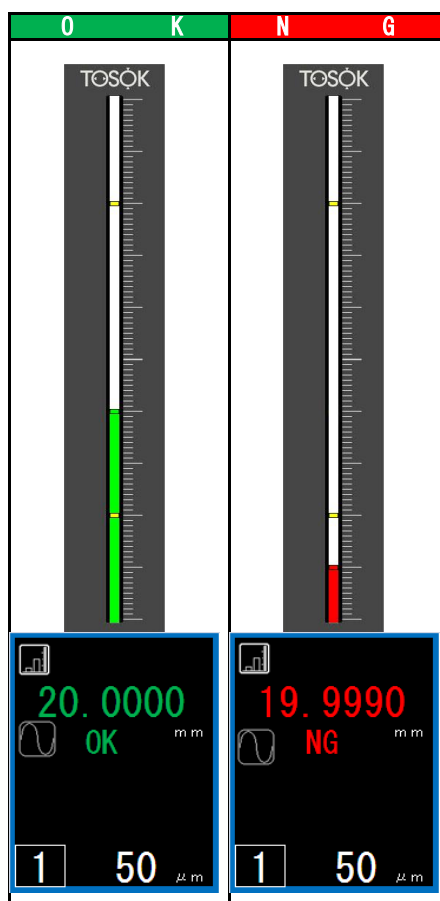



Hold/Output meas. value



Hold the measured value and output it to RS232C.

Caution

- If the mastering is NG, you cannot hold and output the measured value.

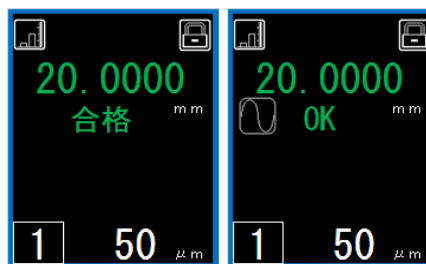
- 1 With the mode display at , press  .
 The measured value shall be held and hold condition  is displayed.
 The measured value and judgement result shall output to RS232C.



- 2 If  is pressed, the  display shall disappear and reset the measured value hold condition.



7 . Setting Procedure

Program change

Input new set values to a program.

⚠ Caution

- In case you will change the settings of the current program, do the following procedure 「Input set value」.

- 1 Turn "ON" the power.
After the opening demo, 「CAL」 shall be displayed.

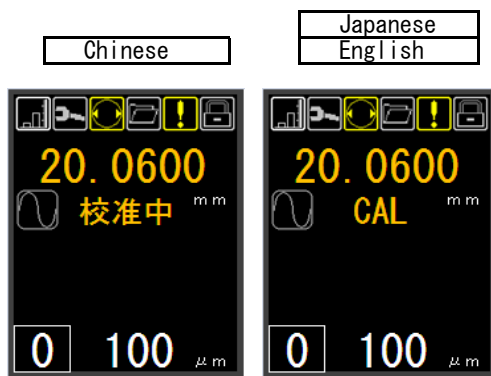

- 2 Press for more than 2 secs.

The mode display will change to

Press .

Upper box displays current program no.
Lower box displays the new program no. input.

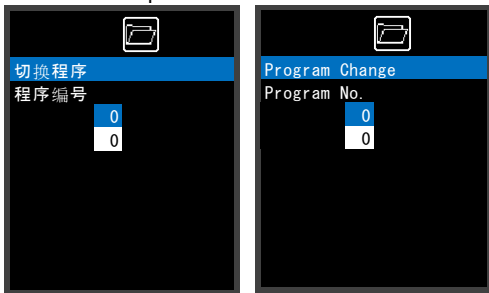

- 4 The program is selected by .

Press and the mode display will change to .

Input set value



Input the new set value of the measurement jig. It is possible to store up to 10 types of measurement conditions.

⚠ Caution

- Changing the measurement range
The user cannot change the measurement range.
In case you need to change the setting, the device has to be pulled out for modification.
- Changing the measure jig JET diameter
In case you need to change the measurement jig JET diameter, the device maybe pulled out for modification.

Important

- The set mode has 2 component displays. 「Set items」 selection display and 「Set values」 input display.

- Selection of set items procedure



There are multiple pages.

Under set item display

Press to 「Select」

then press to 「Set」

- Set values input procedure

Upper box displays current value.



Lower box displays changed value.

Press to move input digit.

Press to change the value.

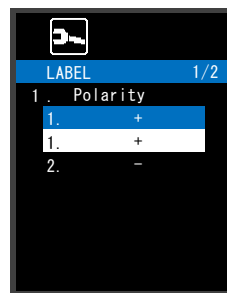
Press to set value.



1 Press  for more 2 seconds
Display will change to  as below

Chinese

设定项目名称	1/2
1. 极性	
2. 选择量程	
3. 公差中间单位	
4. 公差中间值	
5. 上限超差值	
6. 下限超差值	
7. 上限标准件值	
8. 下限标准件值	

English

Label	1/2
1. Polarity	
2. Range	
3. Shift Unit	
4. Shift Value	
5. +NG/ OK	
6. OK/-NG	
7. Max Master	
8. Min Master	

4 Setting the measured value display unit.
Select 「Shift unit」 then SET.
If in μm , select 「1. μm 」
If in mm, select 「2. mm」

Chinese

设定项目名称	1/2
1. 极性	
2. 选择量程	
3. 公差中间单位	
4. 公差中间值	
5. 上限超差值	
6. 下限超差值	
7. 上限标准件值	
8. 下限标准件值	

English

Label	1/2
1. Polarity	
2. Range	
3. Shift Unit	
4. Shift Value	
5. +NG/ OK	
6. OK/-NG	
7. Max Master	
8. Min Master	

2 Setting the polarity.
Select 「Polarity」 then SET.
For Inner diameter, 「1. +」
For outer diameter, 「2. -」

Chinese

设定项目名称	1/2
1. 极性	
2. 选择量程	
3. 公差中间单位	
4. 公差中间值	
5. 上限超差值	
6. 下限超差值	
7. 上限标准件值	
8. 下限标准件值	

English

Label	1/2
1. Polarity	
2. Range	
3. Shift Unit	
4. Shift Value	
5. +NG/ OK	
6. OK/-NG	
7. Max Master	
8. Min Master	

5 Setting shift value of measurements.
Select 「Shift Value」 then SET.
Input 「Work tolerance target value (median)」.

Chinese

设定项目名称	1/2
1. 极性	
2. 选择量程	
3. 公差中间单位	
4. 公差中间值	
5. 上限超差值	
6. 下限超差值	
7. 上限标准件值	
8. 下限标准件值	

English

Label	1/2
1. Polarity	
2. Range	
3. Shift Unit	
4. Shift Value	
5. +NG/ OK	
6. OK/-NG	
7. Max Master	
8. Min Master	

3 Setting the measurement range.
Select 「Range」 then SET.
Select the measurement range as stated on the nameplate of the measurement jig.

Chinese

设定项目名称	1/2
1. 极性	
2. 选择量程	
3. 公差中间单位	
4. 公差中间值	
5. 上限超差值	
6. 下限超差值	
7. 上限标准件值	
8. 下限标准件值	

English

Label	1/2
1. Polarity	
2. Range	
3. Shift Unit	
4. Shift Value	
5. +NG/ OK	
6. OK/-NG	
7. Max Master	
8. Min Master	

6 Setting work upper tolerance limit value.
Select 「+NG/OK」 then SET.
Input upper tolerance limit value.

Chinese

设定项目名称	1/2
1. 极性	
2. 选择量程	
3. 公差中间单位	
4. 公差中间值	
5. 上限超差值	
6. 下限超差值	
7. 上限标准件值	
8. 下限标准件值	
9.	

English

Label	1/2
1. Polarity	
2. Range	
3. Shift Unit	
4. Shift Value	
5. +NG/ OK	
6. OK/-NG	
7. Max Master	
8. Min Master	

- 7 Setting work lower tolerance limit value.
Select 「OK/-NG」 then SET.
Input lower tolerance limit value.

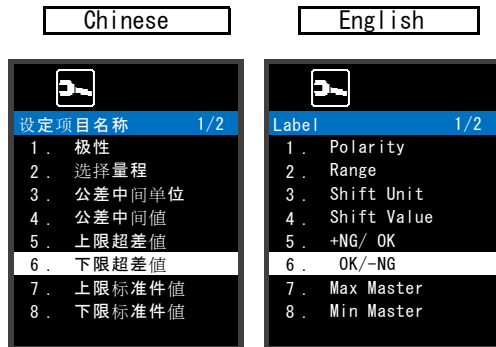

- 10 Setting the language.
Select 「Language」 then SET.
Select preferred display language.

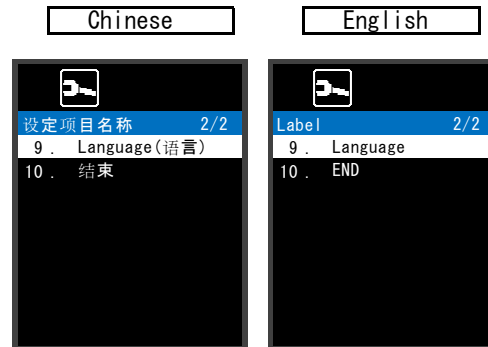

- 8 Setting the max master value.
Select 「Max Master」 then SET.
Input the engraved characters value on the max master.



- 11 Setting all the values changed.
Select 「End」 then SET.
Select 「Cancel」 if you don't want to save the set values.
Select 「Write」 if you want to save the set values.

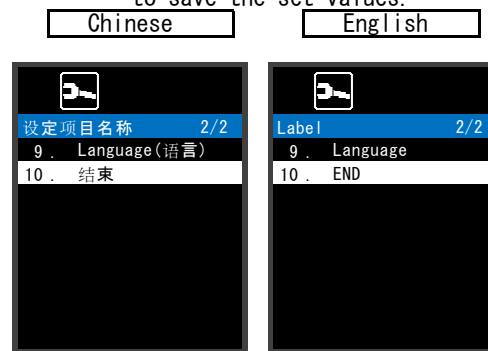

- 9 Setting the min master value.
Select 「Min Master」 then SET.
Input the engraved characters value on the min master.





This concludes the program setting.
Proceed to 「8.Adjustment」

8 . Adjustment

Adjust the standard pressure

Adjust CAG measurement standard pressure.

- 1 Press  for more than 2 secs.
The mode display will change to 

Chinese



English

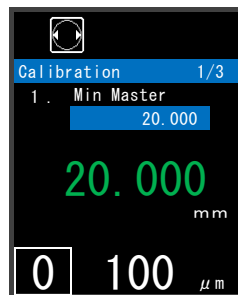

- 2 Press  .
「ADJ」 will be displayed.

Chinese



English

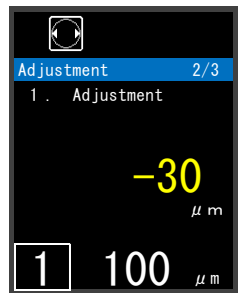

- 3 Turn the ZERO adj knob full to the right then turn it to the left 2.5 times.

ZERO adj. knob

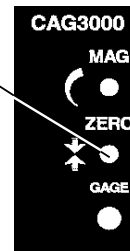

- 4 When the min master and max master is placed, adjust the standard pressure valve so the position of the BAR LED display is divided in the center.

Standard pressure adjustment valve

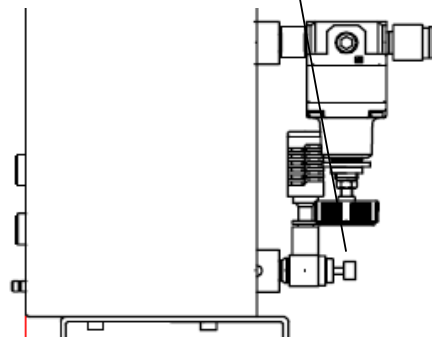

ZERO - MAG Adjustment



Adjusts the ZERO and MAG position of the measurement jig and CAG.

The magnification is adjusted with 「MAG」 and zero is adjusted with 「ZERO」 knob.

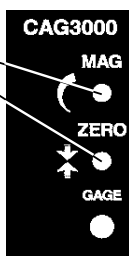

- Adjustment procedure
For inner diameter measurement, proceed to **5**.
For outer diameter measurement, proceed to **8**.

Inner diameter measurement



- 5 Set min master on the measurement jig. Adjust 「ZERO」 so the indicator is close to the min master value.
- 6 Set max master on the measurement jig. Adjust 「MAG」 so the indicator is close to the max master value.
- 7 Set min master on the measurement jig. When the indicator is close to the min master value, the adjustment is completed. Proceed to **11**.

Outer diameter measurement



- 8 Set max master on the measurement jig. Adjust 「ZERO」 so the indicator is close to the max master value.
- 9 Set min master on the measurement jig. Adjust 「MAG」 so the indicator is close to the min master value.
- 10 Set max master on the measurement jig. When the indicator is close to the max master value, the adjustment is completed. Proceed to **11**.

Green bar dot display :

Upper part 「Max master」
Lower part 「Min master」
(set values)

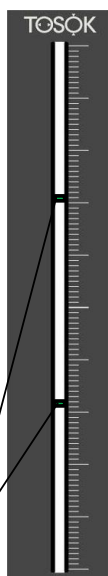

Calibration



Calibration of the min master and max master.

⚠ Caution

- Master
Use only those with no rust or dirt on it.
- Frequency of calibration
In order to maintain the accuracy, it is highly suggested to do the calibration every 2 hours.

- 11 After the adjustment is completed, press **ENT**.

「1. Min Master」 is displayed.

Chinese

English



- 12 Set 「Min Master」 on measurement jig. After the indicators stabilizes, press **ENT**.

After 「Min Master」 is performed, 「2. Max Master」 is displayed.

Chinese

English



- 13 Set 「Max Master」 on measurement jig. After the indicators stabilizes, press **ENT**.

「Max Master」 is performed.

Chinese

English

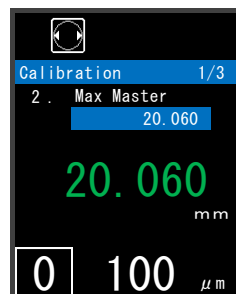

- 14 Check the display of 「TFT LCD」. 「MAS OK」 Mastering is successful. Proceed to measurement.

Chinese

English



「ERR ZERO」
「ERR MAG」 There is error if any of
「ERR REV」 these three appears.

After pressing **ENT**, proceed to **2**

9 . RS232C Output

It is possible to output the measured data(value and judgement) to the RS232C.

⚠ Caution

- If mastering is NG, it is not possible to output the measured results.
- Use cable length of up to 15m only.

Connect the RS232C cable

- Connector cable
The 「RS232C connector」 at the rear side is the connection port.

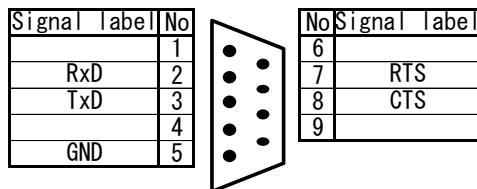

- Serial port settings

Setting label	Set value
Bits / second	9600
Data bits	8
Parity	none
Stop bits	1

- Output data composition

The output data is composed of the 14 characters found below.

- Measured value 8 chars
- Space (SP) 1 char
- Judgement 3 chars
- Control character (CR) 1 char
- Control character (LF) 1 char

Measured value	SP	Judgement	CR	LF
----------------	----	-----------	----	----

Measured results output

- 1 While the mode display is , input "D" only.

- 2 The data below is transmitted out.

Ex .
Measured value 「 20.0000」
In case judgement is 「OK」

	20.0000	SP	OK	CR	LF
SP	2	0.	0	0	0
SP	SP	0	K	CR	LF

10 . External Switch Input

External switch input

If the device is connected with external push button or foot switch, the following operations are possible.

- Output and Hold of measured value.
- Mastering

Caution

- Use cable length of up to 2m only.
- It is possible to connect no voltage contact point push button/foot switch.
- Input connector
Connect to D-SUB15P (Male).

Signal label	No	No	Signal label
	1	9	Max Master
	2	10	Min Master
	3	11	
	4	12	
	5	13	
GND	6	14	
MEAS	7	15	
RESET	8		

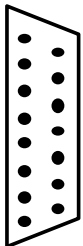



Meas. Value Hold/Output

The output to RS232C and hold of measured value is done with the use of the external switch.

Caution

- If the mastering result is NG, the output and hold of measured value is not possible.

1 With the mode display at ,

turn "ON" the External Switch Input 「MEAS」. The  icon is displayed to

show the measure hold condition. The measured value and judgement result shall be output to the RS232C.

2 Turn "ON" the External Switch Input 「RESET」. The  icon will disappear to show

the measured value hold condition is RESET.

Mastering

Calibration of masters with the use of external switch.

3 Set 「Min Master」 on measurement jig. After the indicators stabilizes, turn "ON" the External Switch Input 「Min Master」. 「Min Master」 is performed.

4 Set 「Max Master」 on measurement jig. After the indicators stabilizes, turn "ON" the External Switch Input 「Max Master」. 「Max Master」 is performed.

5  If this mark disappears, mastering is successful. Proceed to measurement.

 If this mark is blinking, mastering is failed. Please deal with the cause of the mastering error.

General setting



Page	No	設定項目名	Label	設定項目名称	Set Values
		Japanese	English	Chinese	
1/2	1	極性	Polarity	极性	<input type="checkbox"/> 1 . + <input type="checkbox"/> 2 . -
	2	測定レンジ	Range	选择量程	<input type="checkbox"/> 1 . 20 μ m <input type="checkbox"/> 2 . 50 μ m <input type="checkbox"/> 3 . 100 μ m
	3	シフト単位	Shift Unit	公差中间单位	<input type="checkbox"/> 1 . μ m <input type="checkbox"/> 2 . mm
	4	シフト値	Shift Value	公差中间値	
	5	上限判定限界値	+NG/ OK	上限超差値	
	6	下限判定限界値	OK/-NG	下限超差値	
	7	大範マスタ	Max Master	上限标准件値	
	8	小範マスタ	Min Master	下限标准件値	
2/2	9	Language(言語)	Language	Language(语言)	<input type="checkbox"/> 1 . ENGLISH <input type="checkbox"/> 2 . JAPANESE <input type="checkbox"/> 3 . CHINESE
	10	終了	END	结束	

A *Nidec* Group Company

SHIMPO

NIDEC-SHIMPO CORPORATION

:1 Terada Kohtari, Nagaokakyo-city, Kyoto,617-0833 Japan
Phone: 81-75-958-3608 FAX: 81-75-958-3647