

REV	ECN	DESCRIPTION	DATE	ENG'R	CHK'D
A	N/A	RELEASED	May 14/2013	NB	

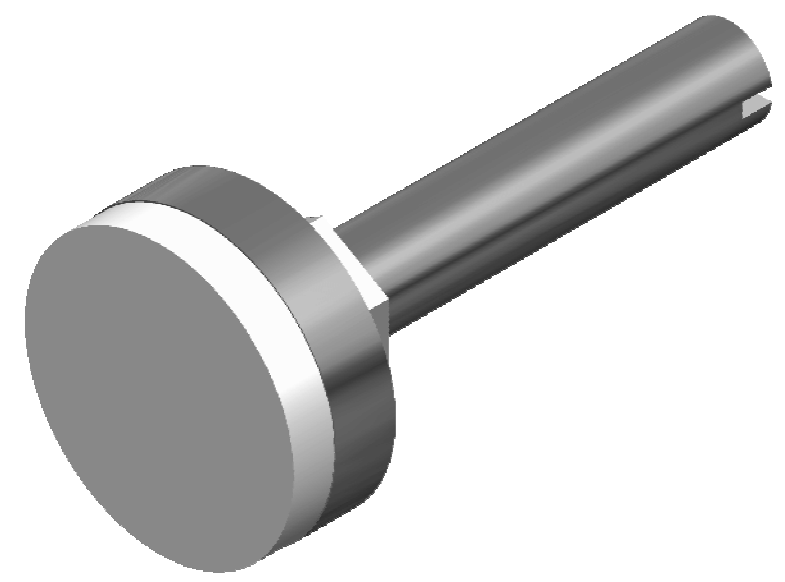
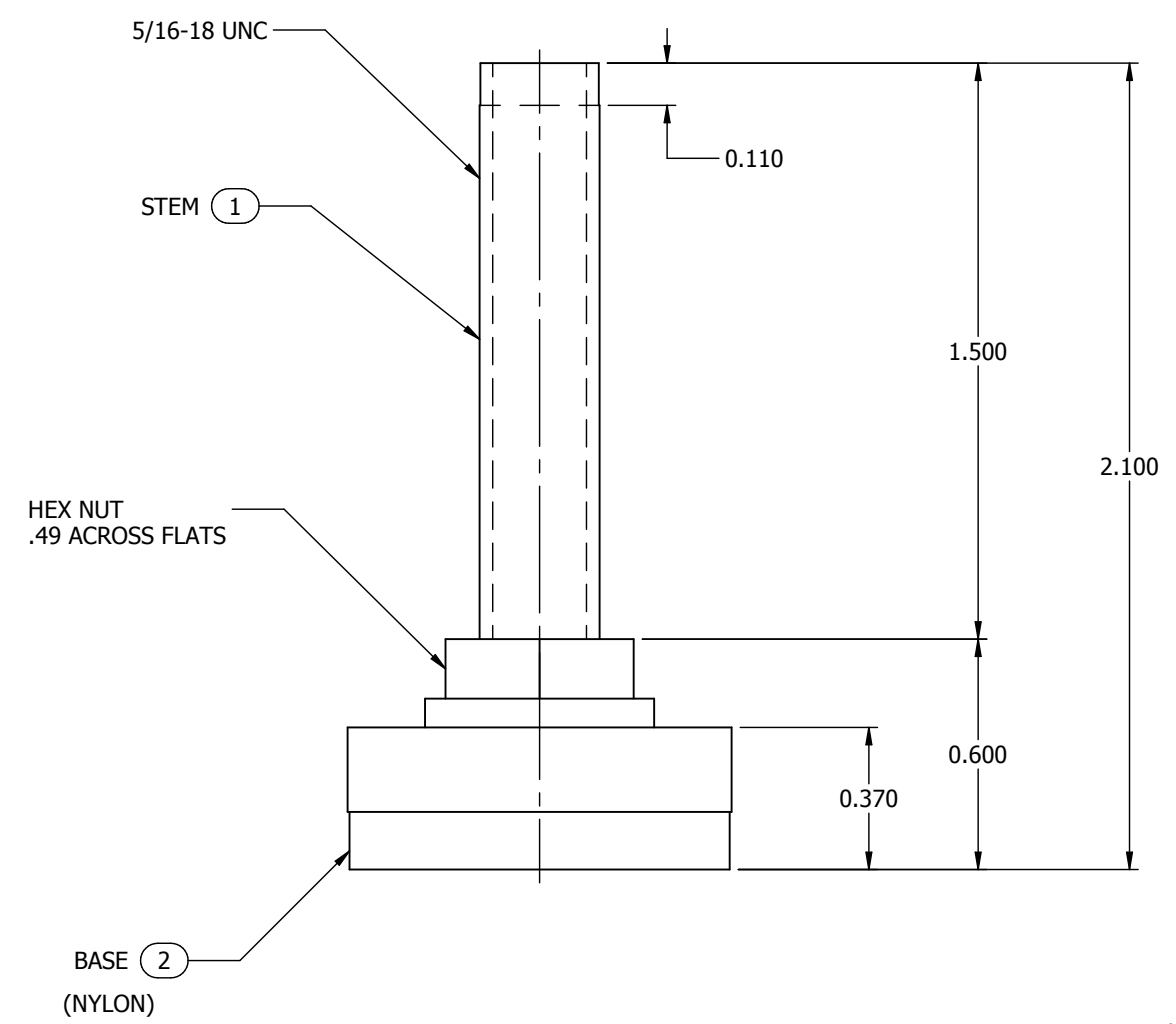
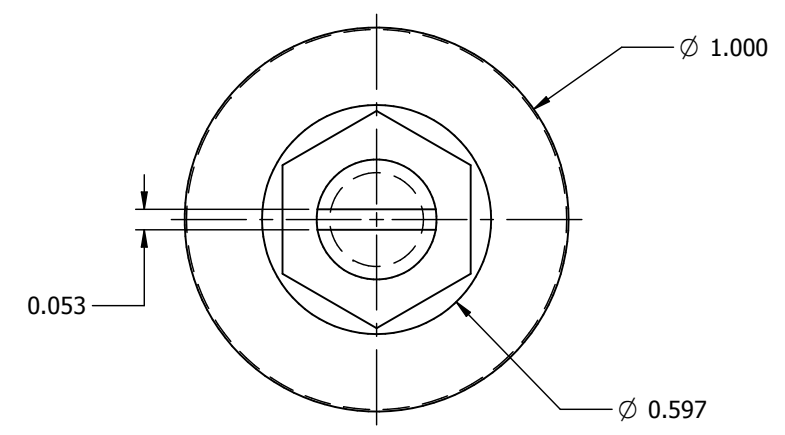

NOTES - UNLESS OTHERWISE SPECIFIED:
 1. REMOVE ALL BURRS AND SHARP EDGES.

UNLESS OTHERWISE SPECIFIED
 ALL DIMENSIONS ARE SHOWN IN INCHES.

TOLERANCES - UNLESS OTHERWISE INDICATED:				
DIMENSION	UNDER 6"	6" TO 24"	OVER 24"	OVER 48"
FRACTION	± 1/32"	± 3/64"	± 1/16"	± 1/8"
.XX	± 0.04"	± 0.05"	± 0.06"	± 0.13"
.XXX	± 0.020"	± 0.020"	± 0.020"	± 0.030"
HOLE Ø	± 0.005"			
ANGLE	± 1°			

N/A		N/A		PART No. CLFK	
MODIFIED FROM		NEXT ASSEMBLY		HAMMOND MANUFACTURING CO. LTD Enclosure Group	
DWN	nbowyer	SHEET SIZE	B	THIS DRAWING IS PROPRIETARY INFORMATION OF HAMMOND MFG. CO. LTD. NOT TO BE USED WITHOUT EXPRESSED WRITTEN PERMISSION OF HAMMOND MFG. CO. LTD.	
DATE	14-May-13			TITLE: Leveling Feet	
CHK.				SCALE: 2:1 DWG: CLFK SHEET: 1 OF 1	
AUTH.					
MAT'L	N/A				
CAD DATA ONLY: DO NOT MANUALLY UPDATE					