

INSTALLATION INSTRUCTIONS

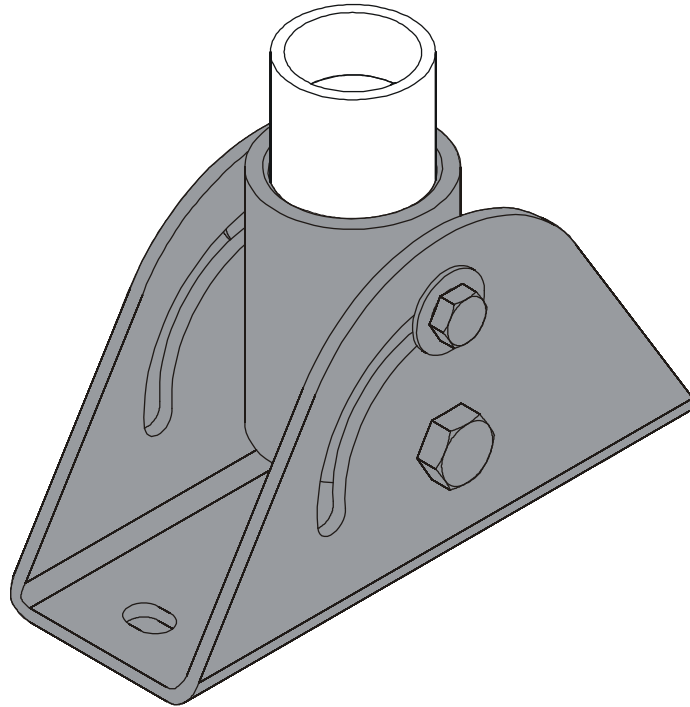

Angled Ceiling Adapter

Touchboards

205 Westwood Ave, Long Branch, NJ 07740
Phone: 866-94 BOARDS (26273) / (732)-222-1511
Fax: (732)-222-7088 | E-mail: sales@touchboards.com

DISCLAIMER

Milestone AV Technologies and its affiliated corporations and subsidiaries (collectively "Milestone"), intend to make this manual accurate and complete. However, Milestone makes no claim that the information contained herein covers all details, conditions or variations, nor does it provide for every possible contingency in connection with the installation or use of this product. The information contained in this document is subject to change without notice or obligation of any kind. Milestone makes no representation of warranty, expressed or implied, regarding the information contained herein. Milestone assumes no responsibility for accuracy, completeness or sufficiency of the information contained in this document.

Chief® is a registered trademark of Milestone AV Technologies. All rights reserved.

IMPORTANT SAFETY INSTRUCTIONS!

 **WARNING:** A WARNING alerts you to the possibility of serious injury or death if you do not follow the instructions.

 **CAUTION:** A CAUTION alerts you to the possibility of damage or destruction of equipment if you do not follow the corresponding instructions.

 **WARNING:** Failure to read, thoroughly understand, and follow all instructions can result in serious personal injury, damage to equipment, or voiding of factory warranty! It is the installer's responsibility to make sure all components are properly assembled and installed using the instructions provided.

 **WARNING:** Failure to provide adequate structural strength for this component can result in serious personal injury or damage to equipment! It is the installer's responsibility to make sure the structure to which this component is attached can support five times the combined weight of all equipment. Reinforce the structure as required before installing the component.

 **WARNING:** Exceeding the weight capacity can result in serious personal injury or damage to equipment! It is the installer's responsibility to make sure the maximum weight installed on the ceiling plate does not exceed 500 lbs (226.8 kg).

- The weight capacity of the CMA395 may be LIMITED to the lowest weight capacity of any other components located between the CMA395 and the supporting structure!

 **WARNING:** Use this mounting system only for its intended use as described in these instructions. Do not use attachments not recommended by the manufacturer.

 **WARNING:** Never operate this mounting system if it is damaged. Return the mounting system to a service center for examination and repair.

 **WARNING:** Do not use this product outdoors.

IMPORTANT ! : The CMA395 must be attached to ceiling using two 3/8 x 2 1/2" lag bolts and 3/8" washers (not included).

NOTE: The CMA395 is designed to be mounted to 2" x 4" or larger wood stud joists. By using any length of 1-1/2" NPT following ANSI/ASME B1.20.1 (Schedule 40, 0.154" minimum thickness aluminum - ASTM B221) threaded extension column with both ends threaded (not included), the height capabilities may be extended as needed.

DIMENSIONS

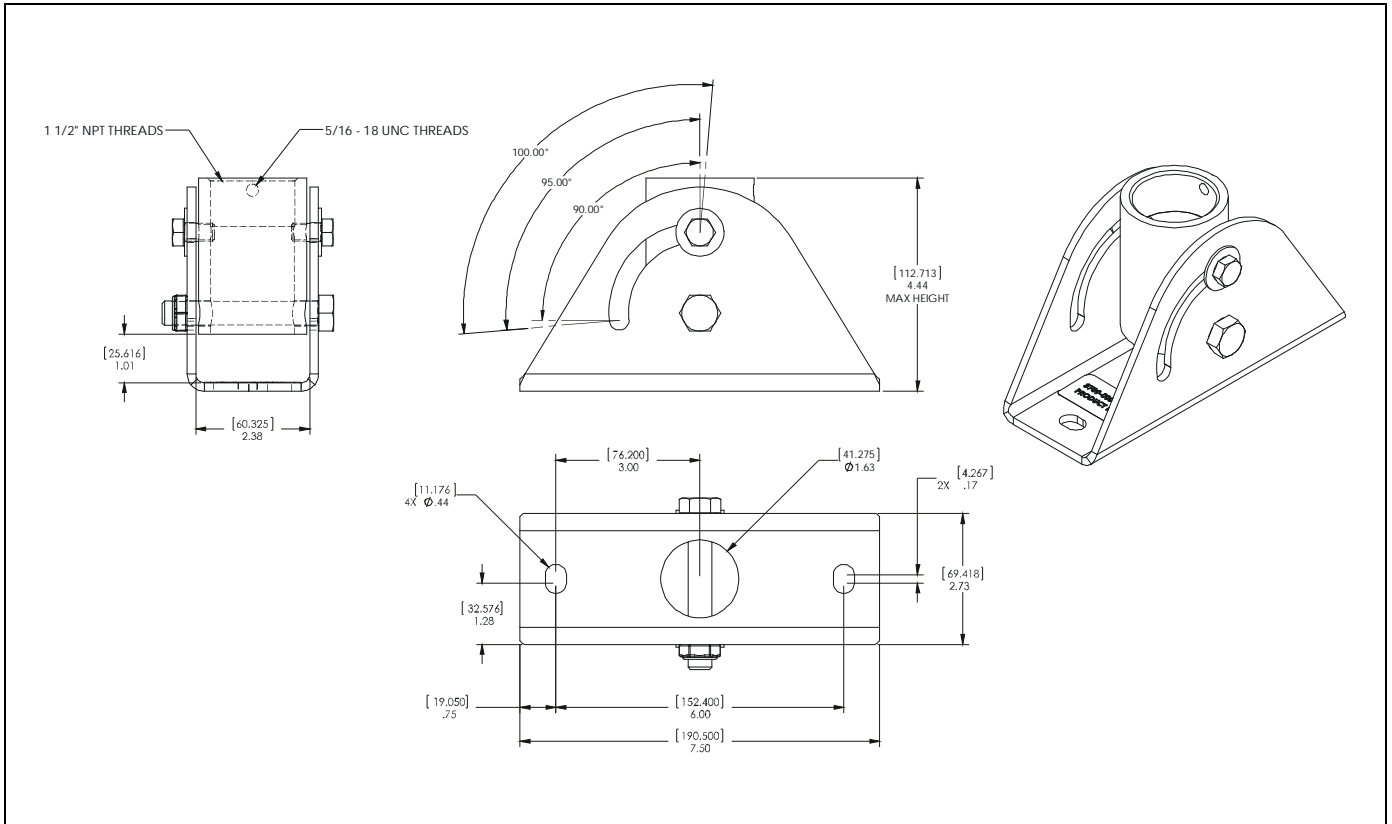

TOOLS / PARTS FOR INSTALLATION

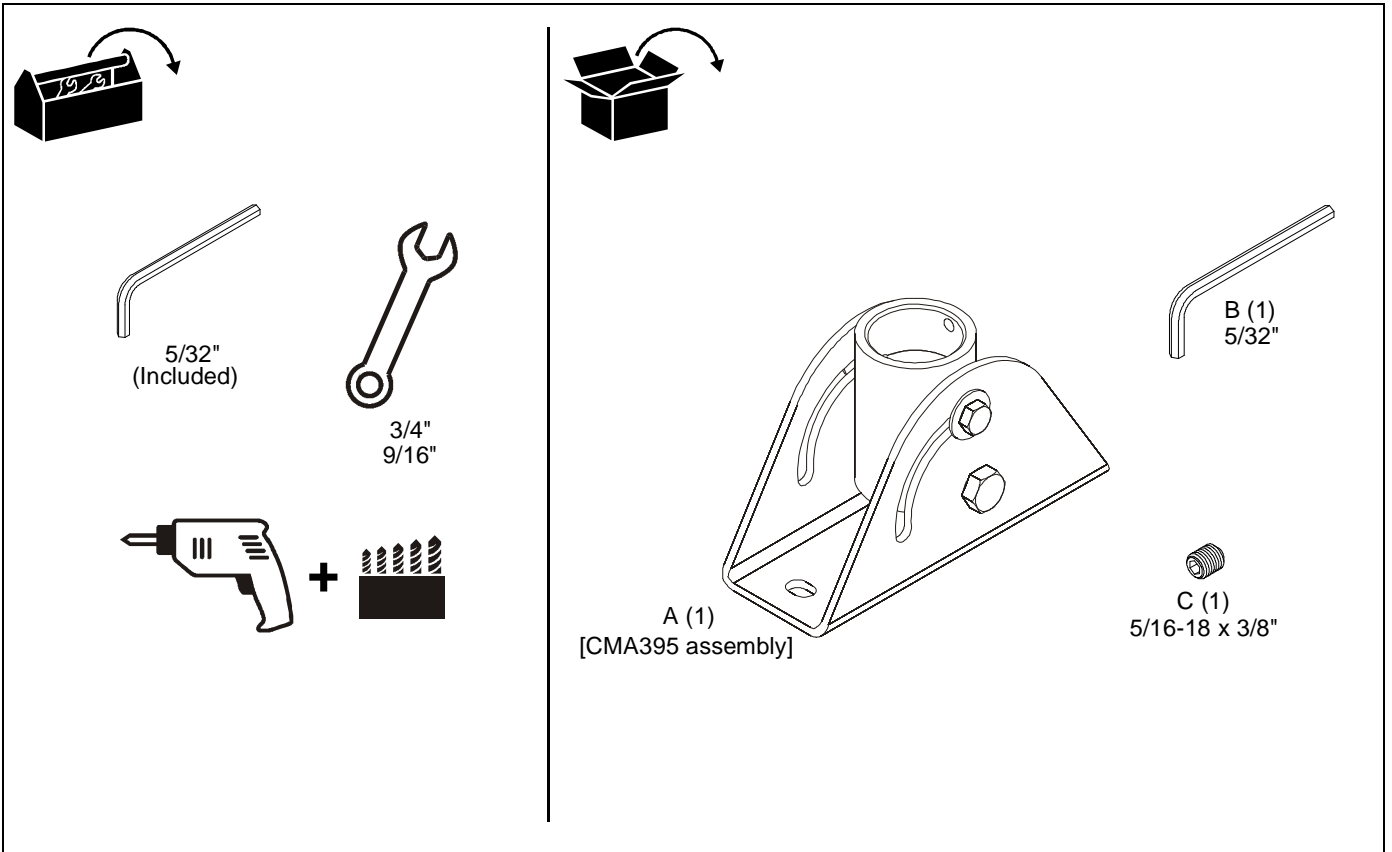

ASSEMBLY AND INSTALLATION

NOTE: The CMA395 ceiling plate is designed for ease of installation with any height of ceiling with 2" x 4" or larger wood joists. By using any length of standard NPT 1 1/2" NPT following ANSI/ASME B1.20.1 (Schedule 40, 0.154" minimum thickness aluminum - ASTM B221) threaded extension column with both ends threaded (not included), the height capabilities may be extended as needed.

1. Loosen two angle adjustment screws to allow for adjustment of pipe coupler angle. (See Figure 1)
2. Adjust pipe coupler to desired angle. (See Figure 1)
3. Tighten two angle adjustment screws. (See Figure 1)
4. Install 1-1/2" NPT following ANSI/ASME B1.20.1 (Schedule 40, 0.154" minimum thickness aluminum - ASTM B221) threaded extension column (not included) into CMA395 until tight, with a minimum of four threads engaged. (See Figure 1)
5. Use set screw (C) to secure extension column to CMA395 coupler. (See Figure 1)

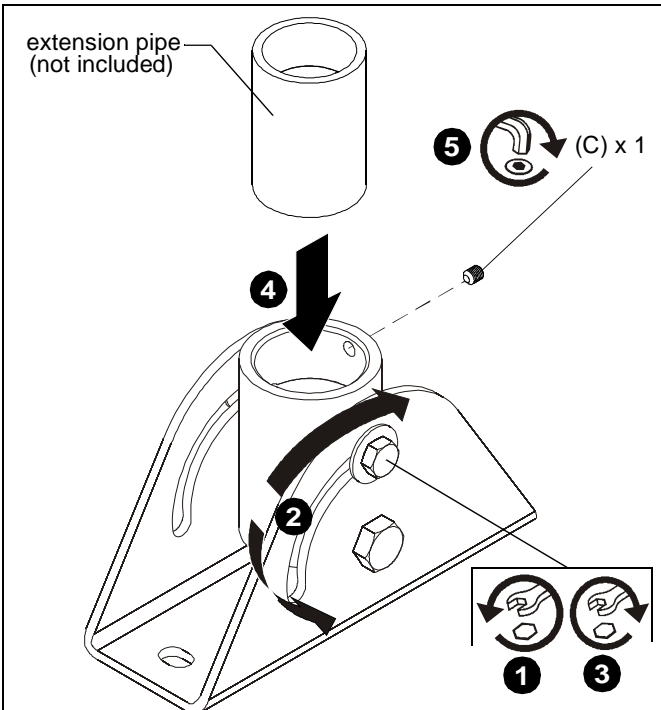

Figure 1

6. Determining mounting location on ceiling.
7. Use CMA395 (A) plate to mark hole locations for ceiling installation. (See Figure 2)



205 Westwood Ave, Long Branch, NJ 07740
 Phone: 866-94 BOARDS (26273) / (732)-222-1511
 Fax: (732)-222-7088 | E-mail: sales@touchboards.com

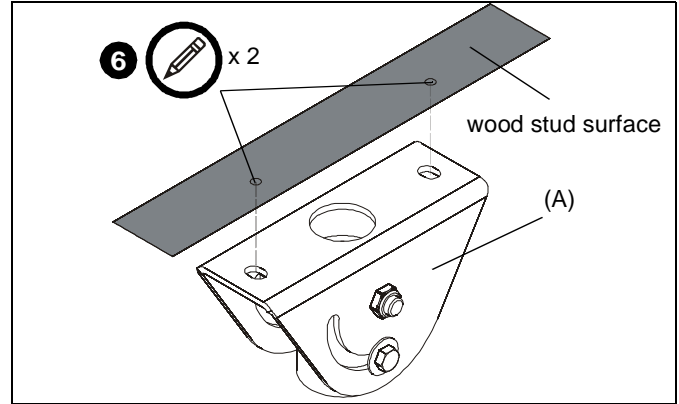

Figure 2

8. Drill two 1/4" pilot holes into wood joists at marked locations.
9. Install CMA395 (A) to ceiling using two 3/8 x 2 1/2" lag bolts (not included) and two 3/8" washers (not included). (See Figure 3)

IMPORTANT ! : The CMA395 must be attached to ceiling using two 3/8 x 2 1/2" lag bolts and 3/8" washers (not included).

WARNING: Failure to provide adequate structural strength for this component can result in serious personal injury or damage to equipment! It is the installer's responsibility to make sure the structure to which this component is attached can support five times the combined weight of all equipment. Reinforce the structure as required before installing the component.

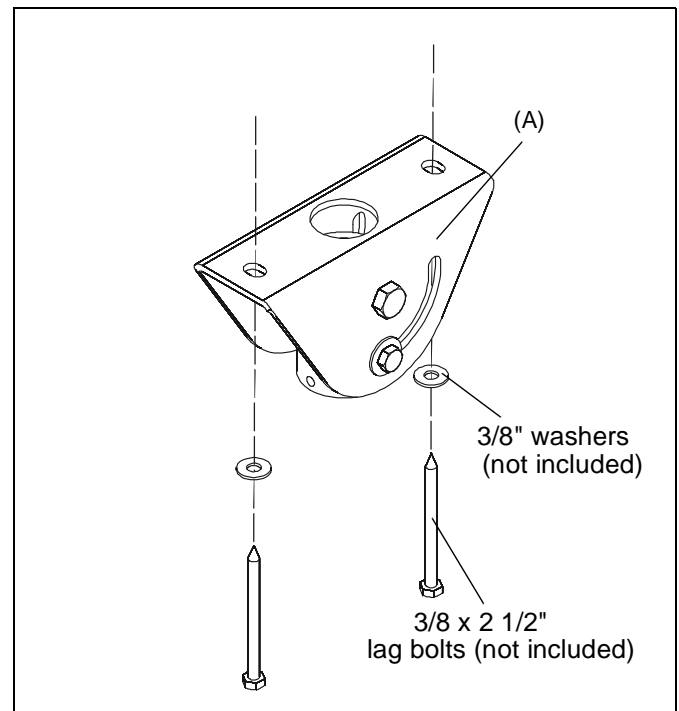

Figure 3

Cable Management

1. If necessary, remove hex head bolt running through pipe channel in order to allow cables to be routed through pipe. (See Figure 4)

NOTE: If cables are small enough to fit between bolt and pipe, bolt does not need to be removed.

2. Route cables through pipe as needed. (See Figure 4)
3. Reinstall hex head bolt and nut after cables have been properly routed. (See Figure 4)

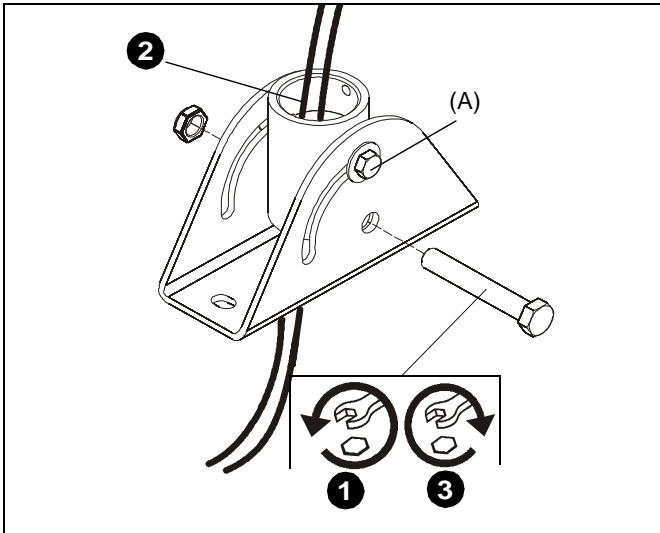

Figure 4

Touchboards

205 Westwood Ave, Long Branch, NJ 07740
 Phone: 866-94 BOARDS (26273) / (732)-222-1511
 Fax: (732)-222-7088 | E-mail: sales@touchboards.com



Our Mounts. **Your Vision.**

Chief Manufacturing, a products division
 of Milestone AV Technologies

8803-002025 Rev02
 ©2012 Milestone AV Technologies, a
 Duchossois Group Company
www.chiefmfg.com
 10/12

USA/International	A 6436 City West Parkway, Eden Prairie, MN 55344
	P 800.582.6480 / 952.225.6000
	F 877.894.6918 / 952.894.6918
Europe	A Franklinstraat 14, 6003 DK Weert, Netherlands
	P +31 (0) 495 580 852
	F +31 (0) 495 580 845
Asia Pacific	A Office No. 1 on 12/F, Shatin Galleria 18-24 Shan Mei Street Fotan, Shatin, Hong Kong
	P 852 2145 4099
	F 852 2145 4477

