

1 1/2" NPT THREADS
5/16 - 18 UNC THREADS

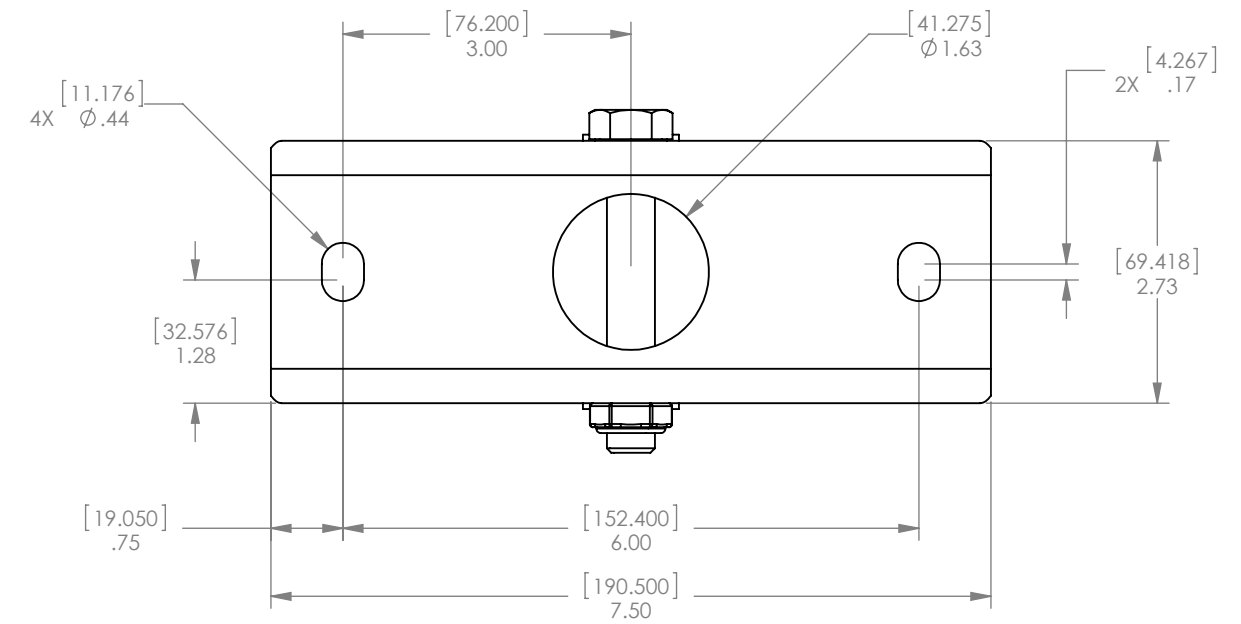

205 Westwood Ave, Long Branch, NJ 07740
Phone: 866-94 BOARDS (26273) / (732)-222-1511
Fax: (732)-222-7088 | E-mail: sales@touchboards.com

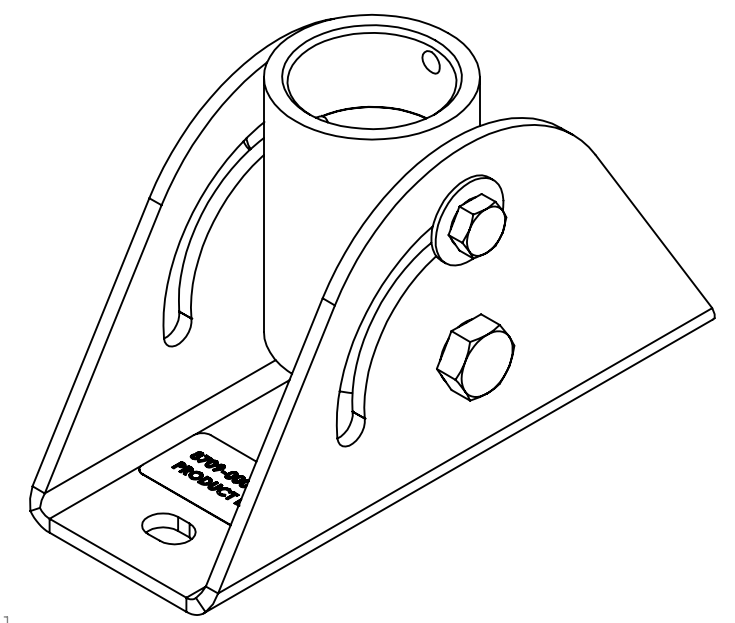
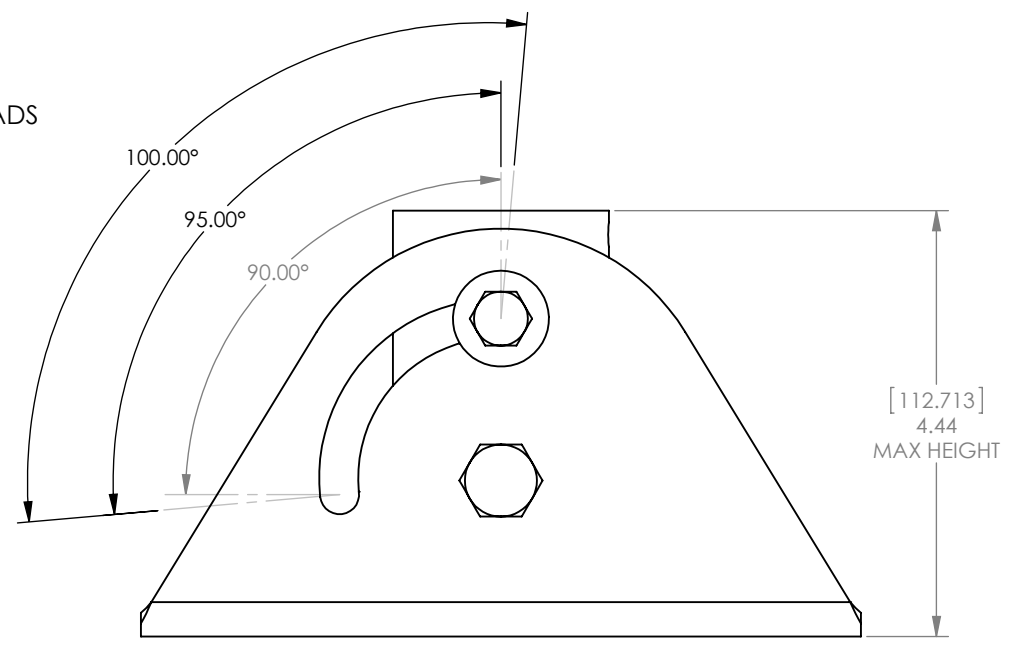
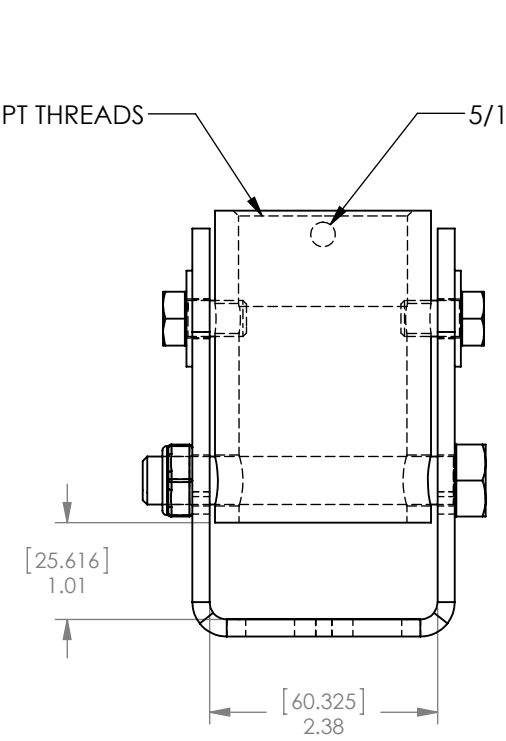

CHIEF MANUFACTURING INC.
MOUNT ORDER NUMBER IS CMA395
PHONE: 1-800-582-6480

THE INFORMATION AND DESIGNS CONTAINED IN THIS DRAWING ARE CONFIDENTIAL AND THE PROPRIETARY PROPERTY OF MILESTONE AV TECHNOLOGIES. NEITHER THIS DESIGN NOR ANY INFORMATION CONTAINED IN THIS DRAWING MAY BE REPRODUCED OR DISCLOSED TO OTHERS WITHOUT THE EXPRESS WRITTEN CONSENT OF MILESTONE AV TECHNOLOGIES.

MAX. WEIGHT 500 LBS.



TITLE
CUSTOMER PRINT,
ASSEMBLY, ANGLED CEILING
ADAPTER CMA395

SIZE | DWG. NO.
B BRACKET ORDER # CMA395