

Carbon Dioxide Meter

Model CO240

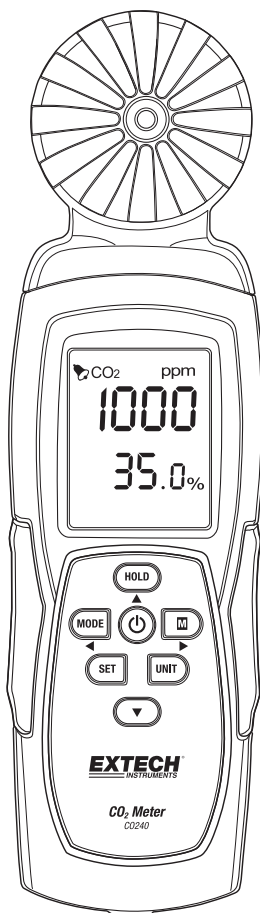

Introduction

Thank you for selecting the Extech Instruments Model CO240. The CO240 measures Carbon Dioxide (CO₂), Air Temperature, and Relative Humidity. It also calculates Dew Point Temperature and Wet Bulb Temperature. The user-programmable high alarm feature alerts the user when CO₂ level rises above the programmed limit and the data streaming feature allows readings to be captured in real time by PC (USB connection). This device is shipped fully tested and calibrated and, with proper use, will provide years of reliable service. Please visit our website (www.extech.com) to check for the latest version of this User Guide, Product Updates, and Customer Support.

Features

- Portable meter measures CO₂, Air Temperature, and Relative humidity accurately
- Measures CO₂ (0~9,999ppm) using NDIR (Non-dispersive Infrared Technology)
- Dual display indicates Relative Humidity/Air Temperature and CO₂
- Calculates Dew Point and Wet Bulb Temperature
- Adjustable CO₂ high alarm threshold with audible beeper
- Tripod mount
- USB cable for PC data streaming (software supplied)
- Battery or AC Adaptor Powered

Meter Description

1. Sensors
2. LCD Screen
3. HOLD / Up Arrow Button
4. MODE / ◀ Left Arrow Button
5. SET Button
6. AC Adaptor jack
7. Tripod Mount
8. POWER (⏻) Button
9. **M** (Max/Min) / ▶ Right Arrow Button
10. UNIT Button
11. ▼ Down Arrow Button
12. USB PC interface port

Battery compartment on rear of meter.

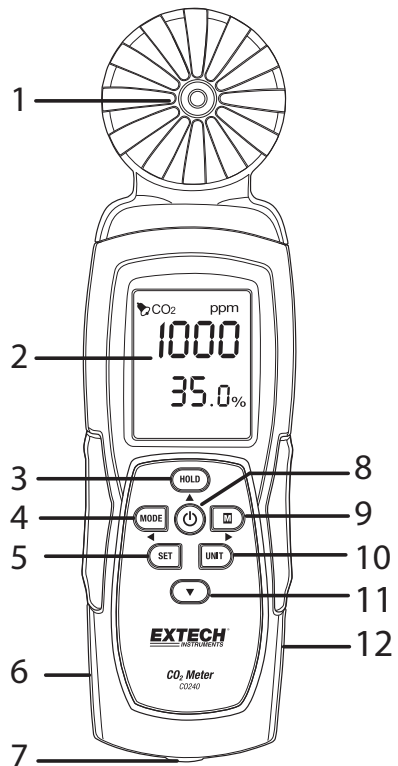

Operation

Powering the meter

Momentarily press the **POWER** button to power on the meter. Hold the **POWER** button for 2 seconds to turn off the meter. During measurement, if the alarm is sounding (audible beeper) press the **POWER** button momentarily to turn off the beeper. Press again to activate the beeper function. The alarm beeper is set to ON by default. The meter can be powered by 6 AAA batteries or AC Adaptor.

Recommendation: For datalogging, power the unit using an AC/DC adaptor in order to conserve battery power.

Auto Power Off

The CO240 will automatically turn off after 20 minutes of inactivity. To disable the auto power off function: With the meter OFF, press and hold the **HOLD** button and then press the **POWER** button. The LCD will show “n”, and will then return to normal measurement mode.

Measurements

When the meter is turned on, a self-test is implemented. Due to the nature of the NDIR sensor, it typically requires approximately ten minutes to obtain stable, accurate readings. If the USB cable is connected to the CO240, the USB symbol will be shown on the LCD.

The temperature and relative humidity readings will alternate on the lower LCD line along with the CO₂ reading on the top display line. Use the MODE button to switch to DP (Dew Point Temperature) and WB (Wet Bulb Temperature) modes (lower display line).

Maximum and Minimum Readings Memory

Momentarily press the **MAX/MIN** button to review the maximum and minimum readings captured since the meter was powered on. Pressing the button once will show the maximum value. Pressing the button again will display the minimum value. Pressing the button a third time will return the meter to its normal mode of operation. While in MAX-MIN mode, press and hold the **HOLD** button for 2 seconds to reset (clear) the stored maximum and minimum values.

Selecting °C/°F units of measure

Press the **UNIT** button to select the desired temperature unit of measure.

Calibration

Press and hold the **SET + UNIT** buttons for 2 seconds to enter the self-calibration mode. Ensure that there is as little CO₂ present as possible. It is recommended that this be done in outside air.

The LCD will display “**CAL**” and will perform a 60-second countdown as it performs the calibration. A reading of “**400**” is displayed as a normal CO₂ level reference value during the calibration. After the calibration has completed, the meter will return to its normal mode operation.

Automatic CO₂ Baseline Calibration (ABC)

The ABC algorithm continually tracks the sensor’s lowest reading over a fixed time interval and slowly corrects for any long-term drift (as compared to the expected fresh air value of 400ppm). The ABC period is 15 days, during which the ABC function default is always on.

CO₂ Alarm Setting

Press and hold the **SET** button for 2 seconds to enter the high CO₂ alarm threshold. Press the **HOLD** button to increase the value, and the **Down arrow** button to decrease the value. Press the **MODE** button to select the digit to the left and press the **MAX/MIN** button to select the digit to the right. Once the desired value is set, press the **SET** button for 2 seconds to save the alarm setting. The LCD will return to its normal mode of operation. The meter alarm limit default is 1000ppm (OSHA). Momentarily press the **POWER** button to toggle the alarm on and off.

Data Streaming to PC

The CO240 features real-time data streaming to a PC using the supplied SW200-S software. When the meter is connected to a PC, the USB icon will be visible on the LCD display. Please install the USB driver and supplied software before attempting to stream data. Refer to the Help Utility within the software program for further details.

Maintenance and Troubleshooting

Battery Replacement

When the battery icon appears on the LCD, the batteries must be replaced.

In a downward motion, slide the rear battery compartment cover off of the meter housing.

Remove the old batteries and replace with new batteries (all of the same type) observing correct polarity. This meter uses six (6) 1.5V AAA batteries. Please replace the battery compartment cover before attempting to use the meter.

Battery Safety Reminders

- Please dispose of batteries responsibly; observe all relevant regulations.
- Never dispose of batteries in a fire; batteries may explode or leak.
- Never mix battery types; install new batteries of the same type.

Troubleshooting / Error Message Displays

Erratic Readings	Replace the batteries or use the AC/DC adaptor and check again.
ER1 Display	CO ₂ , Temperature or Humidity sensor failure or a sensor communication error. Send for service if display persists.
ER2 Display	Out-of-range condition for CO ₂ , Temperature or Relative Humidity. Detected reading exceeds CO ₂ , Temperature or Humidity range specification. This error is normal when clearing the maximum and minimum readings in the MAX/MIN mode.
“9999” Display	Reading exceeds the CO ₂ maximum measurement range or the battery power is weak.

Specifications

Display	Dual multifunction LCD
CO ₂ measure range	0 to 9,999ppm
CO ₂ accuracy	± (75ppm + 5% of reading) 0 to 2,000ppm
Temperature range	14 to 122°F (-10 to 50°C); 0.1° resolution
Temperature Accuracy	± 1.8°F (1.0 °C)
Relative humidity range	10 to 90%RH
Relative Humidity Accuracy	± 5% of rdg at 77°F (25°C) otherwise ±7% RH
Dew Point Temperature range	-99.22 to 118°F (-72.9 to 47°C); 0.1° resolution
Wet Bulb Temperature range	12.2 to 118.8°F (-11 to 48.2°C); 0.1° resolution
Power	AAA batteries x 6 pcs or AC adaptor
Dimensions	8.3 x 2.4 x 1.6" (211 x 60 x 40 mm)
Weight	6.4 oz. (181.4g)

Warranty

FLIR Systems, Inc. warrants this Extech Instruments brand device to be free of defects in parts and workmanship for one year from date of shipment (a six month limited warranty applies to sensors and cables). If it should become necessary to return the instrument for service during or beyond the warranty period, contact the Customer Service Department for authorization. Visit the website www.extech.com for contact information. A Return Authorization (RA) number must be issued before any product is returned. The sender is responsible for shipping charges, freight, insurance and proper packaging to prevent damage in transit. This warranty does not apply to defects resulting from action of the user such as misuse, improper wiring, operation outside of specification, improper maintenance or repair, or unauthorized modification. FLIR Systems, Inc. specifically disclaims any implied warranties or merchantability or fitness for a specific purpose and will not be liable for any direct, indirect, incidental or consequential damages. FLIR's total liability is limited to repair or replacement of the product. The warranty set forth above is inclusive and no other warranty, whether written or oral, is expressed or implied.

Calibration, Repair, and Customer Care Services

FLIR Systems, Inc. offers repair and calibration services for the Extech Instruments products we sell. NIST certification for most products is also provided. Call the Customer Service Department for information on calibration services available for this product. Annual calibrations should be performed to verify meter performance and accuracy. Technical support and general customer service is also provided, refer to the contact information provided below.

Support Lines: U.S. (877) 439-8324; International: +1 (603) 324-7800

Technical Support: Option 3; E-mail: support@extech.com

Repair & Returns: Option 4; E-mail: repair@extech.com

Product specifications are subject to change without notice

Please visit our website for the most up-to-date information

www.extech.com

FLIR Commercial Systems, Inc., 9 Townsend West, Nashua, NH 03063 USA

ISO 9001 Certified

Copyright © 2014-2015 FLIR Systems, Inc.

All rights reserved including the right of reproduction in whole or in part in any form

www.extech.com

Garantie

FLIR Systems, Inc. garantit que cet appareil Extech Instruments est exempt de défauts matériaux et de fabrication pendant un an à partir de la date d'envoi (une garantie limitée de six mois s'applique aux capteurs et aux câbles). Si le renvoi de l'appareil pour réparation devient nécessaire durant ou après la période de garantie, contactez le service client pour autorisation. Pour obtenir les coordonnées, visitez le site Web suivant : www.extech.com. Un numéro d'autorisation de retour (AR) doit être délivré avant tout retour de produit. L'expéditeur prend à sa charge les frais d'expédition, le fret, l'assurance et l'emballage correct de l'appareil afin de prévenir toute détérioration durant le transport. Cette garantie ne s'applique pas aux dommages imputables à l'utilisateur, tels que l'usage impropre ou abusif, un mauvais câblage, une utilisation non conforme aux spécifications, un entretien ou une réparation incorrecte, ou toute modification non autorisée. FLIR Systems, Inc. déclinera spécifiquement toute garantie ou qualité marchande ou aptitude à l'emploi prévu, et ne sera en aucun cas tenu responsable pour tout dommage conséquent, direct, indirect ou accidentel. La responsabilité totale de FLIR est limitée à la réparation ou au remplacement du produit. La garantie définie ci-dessus est inclusive et aucune autre garantie, écrite ou orale, n'est exprimée ou implicite.

Calibrage, réparation et services après-vente

FLIR Systems, Inc. offre des services de calibrage et de réparation pour les produits Extech Instruments que nous commercialisons. Nous fournissons également une certification NIST pour la plupart des produits. Contactez notre service client pour toute information sur les services de calibrage disponibles pour ce produit. Un calibrage doit être effectué chaque année pour vérifier les performances et la précision du mètre. Nous offrons également une assistance technique et un service à la clientèle. Veuillez vous reporter aux coordonnées fournies ci-dessous.

Lignes d'assistance: États-Unis (877) 439-8324; international: +1 (603) 324-7800

Service d'assistance technique : Option 3 ; E-mail : support@extech.com

Réparations et retours : Option 4 ; E-mail : repair@extech.com

Les spécifications produit sont sujettes à modifications sans préavis.

Pour les toutes dernières informations, veuillez visiter notre site Web.

www.extech.com

FLIR Commercial Systems, Inc., 9 Townsend West, Nashua, NH 03063 USA

Certifié ISO 9001

Copyright © 2014-2015 FLIR Systems, Inc.

Tous droits réservés, y compris la reproduction partielle ou totale sous quelque forme que ce soit.

www.extech.com

Garantía

FLIR Systems, Inc., garantiza este dispositivo marca Extech Instruments para estar libre de defectos en partes o mano de obra durante un año a partir de la fecha de embarque (se aplica una garantía limitada de seis meses para cables y sensores). Si fuera necesario regresar el instrumento para servicio durante o después del periodo de garantía, llame al Departamento de Servicio a Clientes para obtener autorización. Visite www.extech.com para Información de contacto. Se debe expedir un número de Autorización de Devolución (AD) antes de regresar cualquier producto. El remitente es responsable de los gastos de embarque, flete, seguro y empaque apropiado para prevenir daños en tránsito. Esta garantía no se aplica a defectos resultantes de las acciones del usuario como el mal uso, alambrado equivocado, operación fuera de las especificaciones, mantenimiento o reparación inadecuada o modificación no autorizada. FLIR Systems, Inc., rechaza específicamente cualesquier garantías implícitas o factibilidad de comercialización o idoneidad para cualquier propósito determinado y no será responsable por cualesquier daños directos, indirectos, incidentales o consecuentes. La responsabilidad total de FLIR está limitada a la reparación o reemplazo del producto. La garantía precedente es inclusiva y no hay otra garantía ya sea escrita u oral, expresa o implícita.

Servicios de calibración, reparación y atención a clientes

FLIR Systems, Inc., ofrece servicios de reparación y calibración para los productos que vendemos de Extech Instruments. Además ofrecemos certificación NIST para la mayoría de los productos. Llame al Departamento de Servicio al Cliente para solicitar información de calibración para este producto. Para verificar el funcionamiento y precisión se debe realizar la calibración anual. Además se provee Soporte Técnico y servicios generales al cliente, consulte la información de contacto en seguida.

Líneas de soporte: EE.UU. (877) 439-8324; Internacional: +1 (603) 324-7800

Soporte Técnico Opción 3; correo electrónico: support@extech.com

Reparación / Devoluciones: Opción 4; correo electrónico: repair@extech.com

Las especificaciones del producto están sujetas a cambios sin aviso

Por favor visite nuestra página en Internet para la información más actualizada

www.extech.com

FLIR Commercial Systems, Inc., 9 Townsend West, Nashua, NH 03063 USA

Certificado ISO 9001

Copyright © 2014-2015 FLIR Systems, Inc.

Reservados todos los derechos, incluyendo el derecho de reproducción total o parcial en cualquier medio

www.extech.com