

PSD-CS

SINGLE AND DUAL LARGE SCREEN PLASMA DISPLAY STANDS

PSD-CS (dual back to back) floor stands adapters are designed to mate directly with any of our flat and tilting style large screen plasma display mounts in a horizontal or vertical display mode. The dual 2" chrome posts or optional black powder coat allow for full-length height adjustability with positive locking of the set height. Optional height adjustable flat accessory shelves or a lockable support equipment cabinet can be mounted above or below the display in the front or rear-facing mode. The dual chrome or black powder coat tubes have cable slots in the base and various points along the tubes to carry cables with in the posts. The base has mounting through holes in each corner for bolting the stand directly to the floor for additional security if needed. Both models are available in 60", 72", and 84" posts length.

PSD-CS

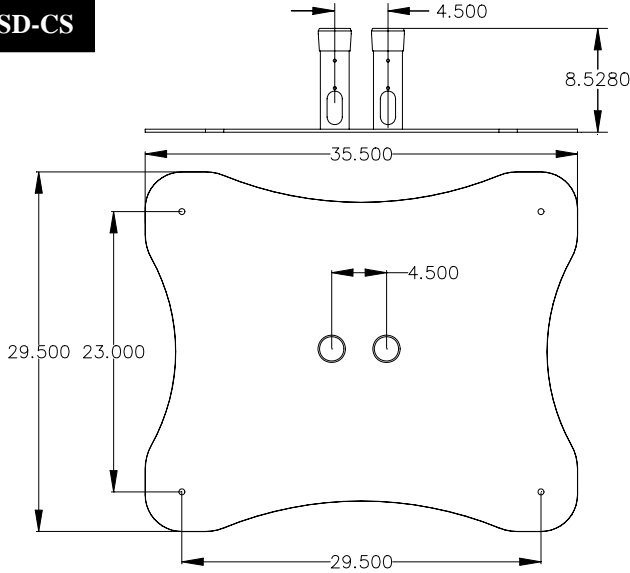

NOTE: PSD-CS adapter stands do not include the Premier plasma mount, which must be added to complete the system.

OPTIONAL ACCESSORIES

- PSD-SHA** - Sinterflex Gray Shelf
- PSD-SHP** - Silver Shelf
- PSD-SPA** - For single display installation
- PSD-DPA** - For dual display installation
- PSD-EXT** - Extension collars (Note): Do not extend any 2" chrome posts beyond 84" high with the PSD-EXT collar.

PSD-CS Hardware

Qty	Description
1	5/32" Short arm hex key
4	M10 Flat washers
4	M10 x 25 (mm) Hex bolts
4	M8 x 10 Socket head screws
2	Cable clips

CAUTION: The PSD-CS dual display stand is designed to work only with two equal weights display mounted back to back for proper center of gravity stability.

WARNING!

The floor structure should be capable of supporting a max weight of 160 Lbs., the weight of the flat panel. More than 160 Lbs the floor must be reinforced. Proper installation procedure by qualified personnel as outlined in the installations instructions must be adhered to. Failure to do so could result in serious personal injury.

PREMIER MOUNTS

A DIVISION OF PROGRESSIVE MARKETING INC.

3130 E. Miraloma Avenue Anaheim, CA 92806

Ph (800) 368-9700 Fax (800)832-4888

E-mail: mounts@pmpl.com Web Site: www.mounts.com



PSD-CS Installation procedures

Installing the tubes

Step 1

The PSM and CTM series mount is required to complete the PSD-CS system. Refer to its installation instructions to install the plasma display bracket.

The location of the stand must be a flat surface. Remove the stand out of the box and check for all proper hardware, if missing any hardware please call **Premier Mounts Inc.** Insert the tubes over the base columns making sure there fully seated on the base and the cable access facing the rear of the base. Secure the tubes with four (4) of the M8 x 10 Socket head screws and hex key (supplied). Do not over tighten the hex screws.

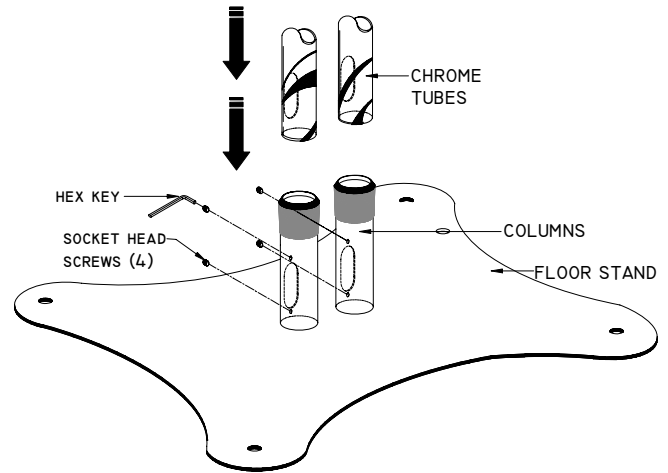

Installing the back plate to the floor stand

Step 3

Slide the PP-ADAP for single display installation. **NOTE:** If using the PSD-CS floor stand for dual display installation use the PSD-DPA adapter. Through the tubes, slide the adapter to the viewing height desired on the stand then secure with the two (2) M8 x 10 (mm) socket screws and tighten with the hex key (supplied). Install and secure the universal flat wall bracket (PDB-UWFB) arrow facing up with the four (4) M10 x 12 (mm) Hex bolts and flat washers (supplied) to the PP-ADAP / PSD-SPA / PSD-DPA adapters.

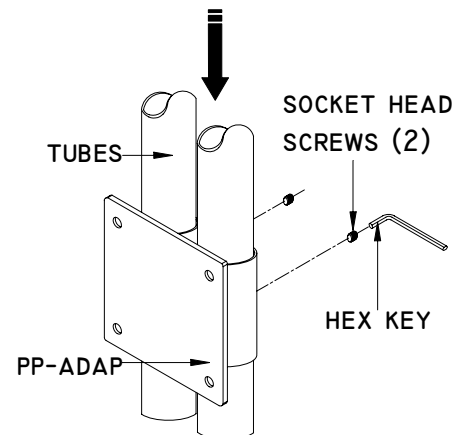

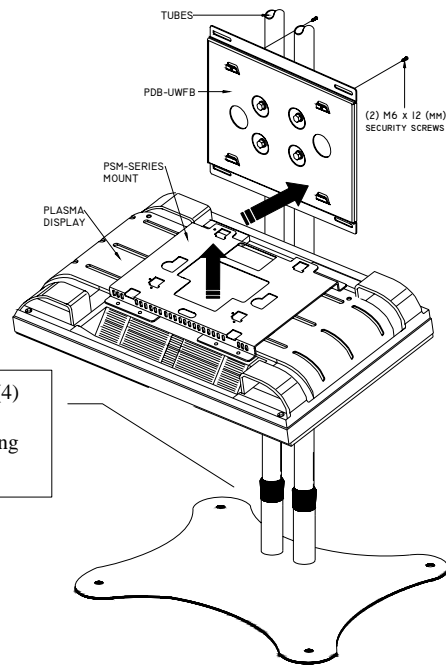
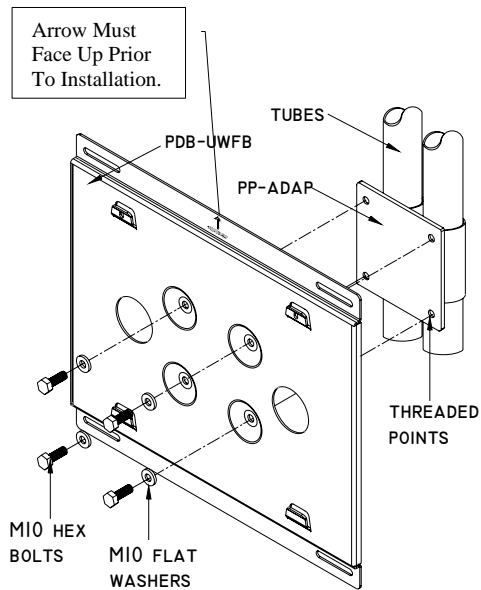

Installing the plasma display to the floor stand

Step 4

CAUTION: Two persons are required to complete the next step. The plasma display is heavy and may be dropped, scratch or personal injury may result if mishandled.

Refer to the PSM-Model installation instructions to secure the plasma display bracket to the plasma.

CAUTION: Make sure the hardware from the PSM-Series mount is secured to the plasma display before engaging the mounts together.

The location of the floor stand must be chosen at this time, if not choose the location and move the floor stand to it.

CAUTION: Do not move the floor stand with the plasma attached possible tilting of the floor stand may occur resulting in personal injury and damage to the plasma display.

Raise the plasma display (2 people required) with the PSM series mount safely attached to the plasma display and insert the four (4) opening found on the mounting bracket to the four (4) receiving tabs on the universal flat bracket (PDB-UWFB). Make sure the receiving tabs and tab openings are aligned, interlock both brackets together.

WARNING: Do not let go of the plasma display until all four (4) tabs are interlocked. Failure to do so may result on the plasma not being balanced and mounted incorrectly.

For security

Step 5

For **PSM-FLAT SERIES** use the two (2) M6 x 12 (mm) security screws (supplied) for additional security. On the **PSM-TILT SERIES** open the mount to it's full tilt mode and secure the two (2) M6 x 12 (mm) security screws (supplied) for additional security. Check that all hardware is properly tighten and secured.

Installing optional accessory

Step 2

If using any of the optional accessories on the floor stand, install at this time if you want the accessory underneath the plasma display. Slide the accessory over the tubes and secure with the two (2) M8 x 10 socket head screw and hex key to tighten at the height desired.

NOTE: The plasma display must be installed first if the optional accessories are going to be installed above the plasma display.

Securing the floor stand to the ground (Optional)

If securing the floor stand to the ground structure use the four (4) though holes on the base of the floor stand and use suitable hardware (commercially available) to secure the base.

Plasma height adjustment

CAUTION: 2 people required to adjust the height of the plasma. Hold the plasma and carry the eight of the plasma. Loosen the two (2) M8 x 10 (mm) socket head screws with the hex key and adjust the height. Once the height is achieved re-tighten the two (2) M8 x 10 (mm) socket head screws.

Horizontal to Vertical

CAUTION: 2 people required to adjust the height of the plasma. Hold the plasma and carry the eight of the plasma. Remove the two (2) M6 x 12 (mm) security screws and disengage to rotate the plasma 90° to the right and re-engage the plasma to the tabs. Secure the M6 x 12 (mm) security screws.

Installing optional accessory

Step 2

If using any of the optional accessories on the floor stand, install at this time if you want the accessory underneath the plasma display. Slide the accessory over the tubes and secure with the two (2) M8 x 10 socket head screw and hex key to tighten at the height desired.

NOTE: The plasma display must be installed first if the optional accessories are going to be installed above the plasma display.



205 Westwood Ave, Long Branch, NJ 07740
 Phone: 866-94 BOARDS (26273) / (732)-222-1511
 Fax: (732)-222-7088 | E-mail: sales@touchboards.com