

INSTALLATION INSTRUCTIONS

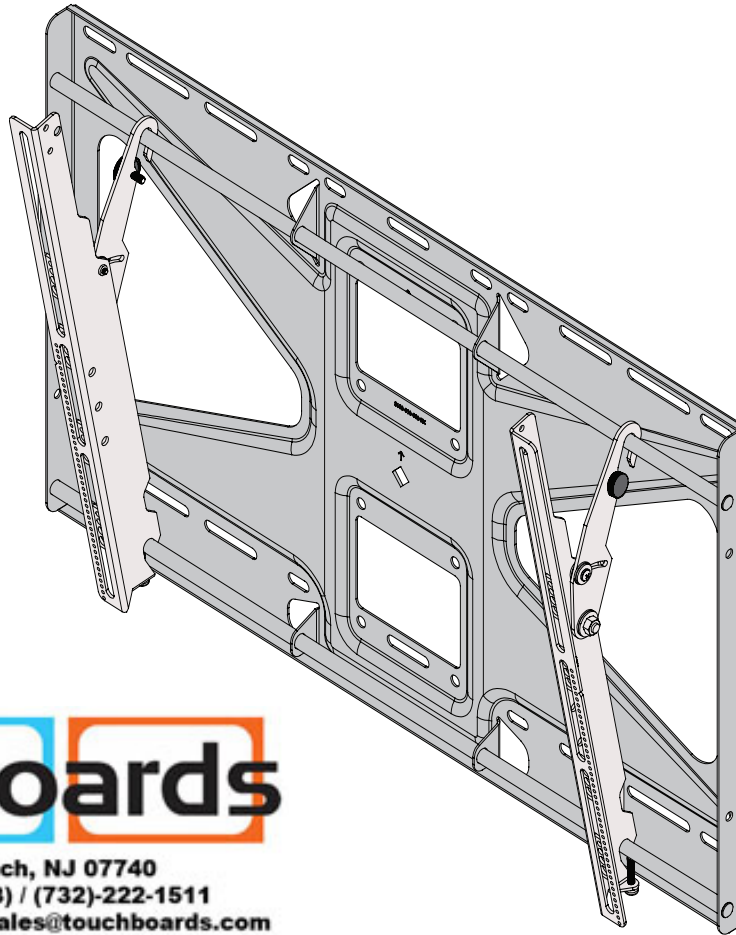

Touchboards

205 Westwood Ave, Long Branch, NJ 07740
Phone: 866-94 BOARDS (26273) / (732)-222-1511
Fax: (732)-222-7088 | E-mail: sales@touchboards.com

Tilting Wall Mount for 37" to 63" Flat Panels

Model: CTM-MS2

WORLD HEADQUARTERS

1321 S. State College Blvd.
Fullerton, CA 92831 USA
USA and Canada
Phone: 1-800-368-9700
Fax: 1-800-832-4888
Other Locations
Phone: (001) 714-632-7100
Fax: (001) 714-632-1044



Contents

Weight Limit.....	2
Warning Statements.....	2
Installation Tools.....	3
Parts List.....	3
Installing the Wall Plate.....	4
Introduction.....	4
Installing the Mounting Brackets.....	6
Selecting the Mounting Hardware.....	6
Griplate™ Washer Installation.....	7
Nylon Spacer Installation.....	7
Attaching the Mounting Brackets to the Flat Panel.....	8
Mounting the Flat Panel.....	8
Attaching the Flat Panel to the Wall Plate.....	8
Safety Knurl Knob Installation.....	9
Locking Safety Screw Installation.....	10
Tilt Adjustment.....	10
Warranty.....	11

Weight Limit

Maximum Flat Panel Weight: **175 lb./ 79.38 kg**

THE WALL STRUCTURE MUST BE CAPABLE OF SUPPORTING AT LEAST FIVE TIMES THE WEIGHT OF THE FLAT PANEL. IF NOT, THE WALL STRUCTURE MUST BE REINFORCED.

Warning Statements



PRIOR TO THE INSTALLATION OF THIS PRODUCT, THE INSTALLATION INSTRUCTIONS MUST BE READ AND COMPLETELY UNDERSTOOD. KEEP THESE INSTALLATION INSTRUCTIONS IN AN EASILY ACCESSIBLE LOCATION FOR FUTURE REFERENCE.



PROPER INSTALLATION PROCEDURE BY A QUALIFIED SERVICE TECHNICIAN MUST BE FOLLOWED, AS OUTLINED IN THESE INSTALLATION INSTRUCTIONS. FAILURE TO DO SO COULD RESULT IN PROPERTY DAMAGE, SERIOUS PERSONAL INJURY, OR EVEN DEATH.



SAFETY MEASURES MUST BE PRACTICED AT ALL TIMES DURING THE ASSEMBLY OF THIS PRODUCT. USE PROPER SAFETY EQUIPMENT AND TOOLS FOR THE ASSEMBLY PROCEDURE TO PREVENT PERSONAL INJURY.



PREMIER MOUNTS DOES NOT WARRANT AGAINST DAMAGE CAUSED BY THE USE OF ANY PREMIER MOUNTS PRODUCT FOR PURPOSES OTHER THAN THOSE FOR WHICH IT WAS DESIGNED OR DAMAGE CAUSED BY UNAUTHORIZED ATTACHMENTS OR MODIFICATIONS, AND IS NOT RESPONSIBLE FOR ANY DAMAGES, CLAIMS, DEMANDS, SUITS, ACTIONS OR CAUSES OF ACTION OF WHATEVER KIND RESULTING FROM, ARISING OUT OF OR IN ANY MANNER RELATING TO ANY SUCH USE, ATTACHMENTS OR MODIFICATIONS.



At least two qualified people should perform the assembly procedure. Personal injury and/or property damage can result from dropping or mishandling the flat panel.



If mounting to wall studs or ceiling studs, make sure that the mounting screws are anchored into the center of the wall studs or ceiling studs. Use of an edge-to-edge stud finder is recommended.



It is recommended that a maximum of 5/8" plaster board be used when mounting to wooden studs.



Be aware of the mounting environment. If drilling and/or cutting into the mounting surface, always make sure that there are no electrical wires in wall. Cutting or drilling into an electrical line may cause serious personal injury.



Make sure there are no water or natural gas lines inside the wall where the mount is to be located. Cutting or drilling into a water or gas line may cause severe property damage or personal injury.



This product is intended for indoor use only. Use of this product outdoors could lead to product failure and/or serious personal injury.



Do not install near sources of high heat. Do not install on a structure that is prone to vibration, movement or chance of impact.







Contact Premier Mounts with any questions:
(800) 368-9700
mounts@mounts.com



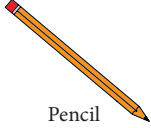
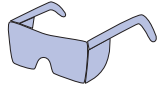

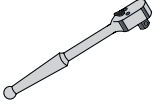

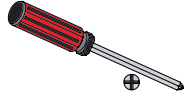





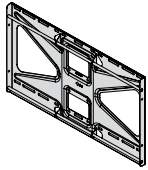









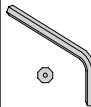

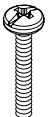

Installation Tools

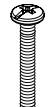
The following tools may be required, dependent upon your particular installation. These tools are not provided by Premier Mounts, but you can purchase them at your local hardware store.

 Electronic Stud Finder	 Pencil	 Protective Eyewear	 Portable Drill	 1/4 " Drill Bit
 Socket Wrench	 1/2 " Socket	 Phillips Head Screwdriver		

Parts List

Your Premier Mounts product is shipped with all proper installation hardware and components. Make sure that none of these parts are missing and/or damaged before beginning installation. If there are parts missing and/or damaged, please stop the installation and contact Premier Mounts at 1-800-368-9700.

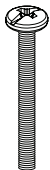
CTM-MS2 Tilting Wall Mount Assembly Components							
 x1 Wall Plate	 x2 Mounting Bracket	 x1 Thread Depth Indicator (Supplied)	 x6 Griplate™ Washer	 x2 M6 Safety Knurl Knob	 x24 Universal Spacers	 x2 Panelock™ Hardware Kit	
 x6 5/16 " x 3" Lag Bolt	 x6 5/16 " Flat Washer	 x2 M6 x 30mm Locking Safety Screw	 x2 M6 x 12mm	 x1 Security Head Allen Wrench	 x6 M4 x 16mm	 x6 M4 x 25mm	 x6 M4 x 30mm
 x6 M5 x 16mm	 x6 M5 x 25mm	 x6 M5 x 30mm	 x6 M6 x 16mm	 x6 M6 x 25mm	 x6 M6 x 30mm	 x6 M6 x 45mm	 x6 M8 x 16mm
 x6 M8 x 25mm	 x6 M8 x 30mm	 x6 M8 x 45mm	 x4 M8 x 70mm				





Installing the Wall Plate

Introduction



Directional Mounting Arrow

The Directional Mounting Arrow stamped into the CTM-MS2 wall plate indicates which edge is the top.



Visual Centering Diamond

The Visual Centering Diamond will guide you in determining the screen placement on the wall.



Mounting Safety

Two people are recommended to install the wall plate.

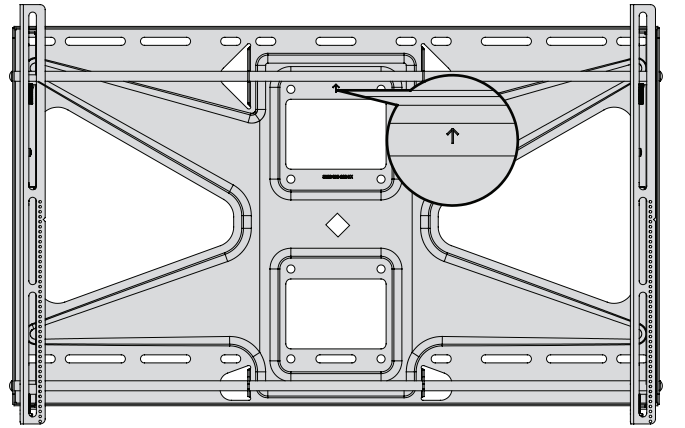

Step 1



You must secure the wall plate to two (2) wall studs with four (4) lag bolts (2 lag bolts for each stud found)

- 1) Use a stud finder to determine the exact center of wall studs in the vicinity of the wall plate.
- 2) Use a pencil to mark the exact center of each of the wall studs.

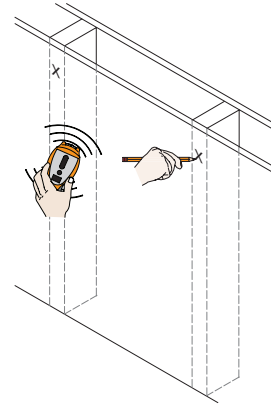

Step 2



Two people are recommended for this step; one person to level the wall plate and another person to mark the wall stud location.

- 1) Place the wall plate against the wall in the desired viewing location.
- 2) Adjust the wall plate to align the mount slots in the wall plate with the center of the wall studs.
- 3) Level the wall plate.
- 4) Use a pencil to mark the upper right mounting location along the center of the wall stud.

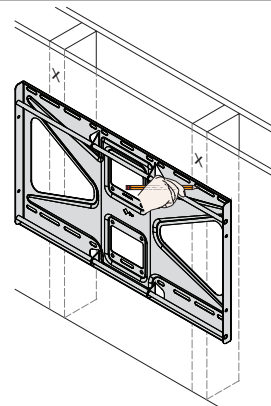

Step 3

Drill a "pilot hole" in the center of the upper right mark using a 1/4" drill bit and power drill.



Only use a 1/4" drill bit when drilling pilot holes.

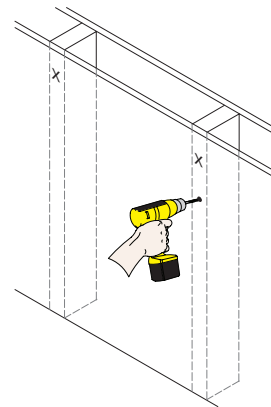



Installing the Wall Plate (cont'd)

Step 4

- 1) Place the wall plate against the wall and align it with the pilot hole.
- 2) Insert one (1) $\frac{5}{16}$ " x 3" lag bolt and one (1) $\frac{5}{16}$ " washer into the upper right pilot hole.
- 3) Use a socket wrench and a $\frac{1}{2}$ " socket to tighten the lag bolt.



Do not overtighten the lag bolt.

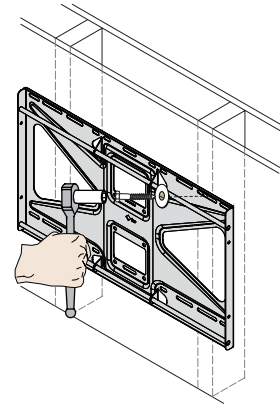

Step 5

- 1) Level the wall plate.
- 2) Use a pencil to mark the remaining three (3) mounting locations along the center of each wall stud.

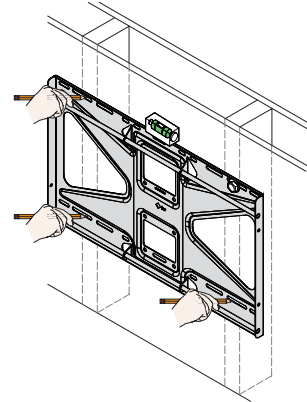

Step 6



Two people are recommended for this step; one person to level the wall plate and another person to drill the pilot holes.

Drill a "pilot hole" in the center of each of the marks with a power drill and a $\frac{1}{4}$ " drill bit.



Only use $\frac{1}{4}$ " drill bit when drilling the pilot holes.

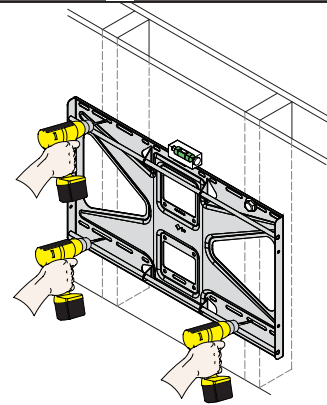

Step 7

- 1) Insert one (1) $\frac{5}{16}$ " x 3" lag bolt and one (1) $\frac{5}{16}$ " washer into each pilot hole
- 2) Tighten all lag bolts using a socket wrench and $\frac{1}{2}$ " socket.



Do not overtighten the lag bolts when attaching the mount to the wall. Improper installation may result in personal injury or property damage.

Proceed to the "Installing the Mounting Bracket" on page 8.

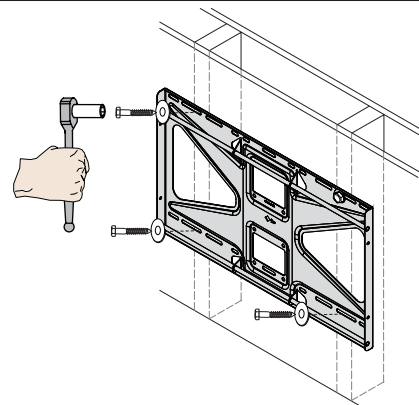



Installing the Mounting Brackets

Selecting the Mounting Hardware

- 1) Insert a small straw or toothpick into the threaded inserts found on the back of the flat panel.
- 2) Use a pencil to mark the depth of the threaded insert on the small straw or toothpick.
- 3) Mark the straw or toothpick 1/8" above the depth of the threaded insert, as shown in Figure 1.
- 4) Insert the small straw or toothpick into the remaining threaded inserts to compare and verify their depth using the straw or toothpick's 1/8" allowance mark.
- 5) Locate the correct diameter screw for the threaded insert.



If the screw you selected is longer than the 1/8" allowance mark on the small straw or toothpick, as shown in Figure 2 and Figure 3, do not use this screw. The screw length must not bypass the mark.

- 6) Test each size of the screws provided.

The correct screws should thread easily into the mounting point and not pull out when tension is applied.

Proceed to the "Griplate™ Installation" section.

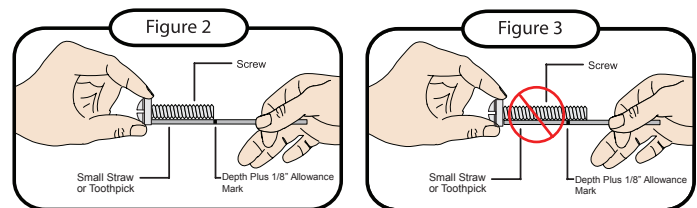
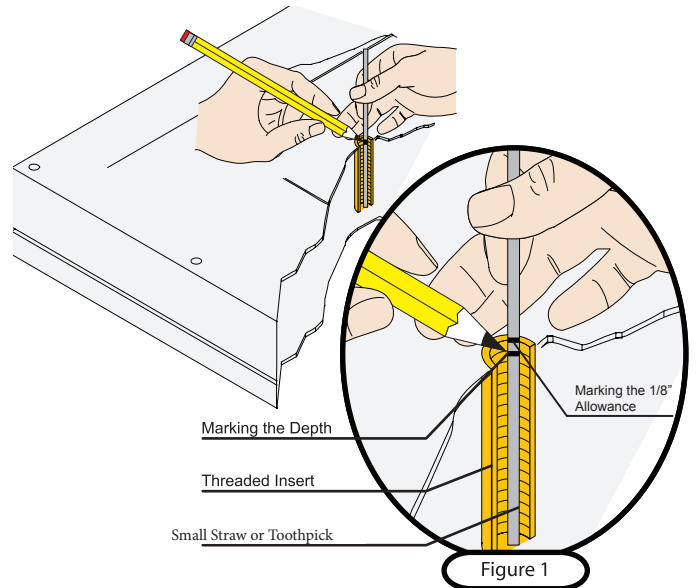



Installing the Mounting Brackets (cont'd)

Griplate™ Installation

Premier Mounts' Universal Washers are designed to accommodate the various M4, M5, M6 and M8 hole sizes required by flat panels.



Do not place excessive pressure on the back of the flat panel, as this may damage the flat panel.



The Universal Washer must be installed between the head of the mounting screw and the mounting bracket as shown with dimples facing down.



Does the flat panel have:

- Recessed mount points?
- Uneven mount points?
- A curved back?
- Any obstruction near the mount point?

If **Yes**, you must install Universal Spacers. Remove the mounting brackets, Universal Washers, and mounting screws from the back of the flat panel. Proceed to the "Universal Spacer Installation" below.

If **No**, skip to the "Attaching the Mounting Bracket to the Flat Panel" on page 10.

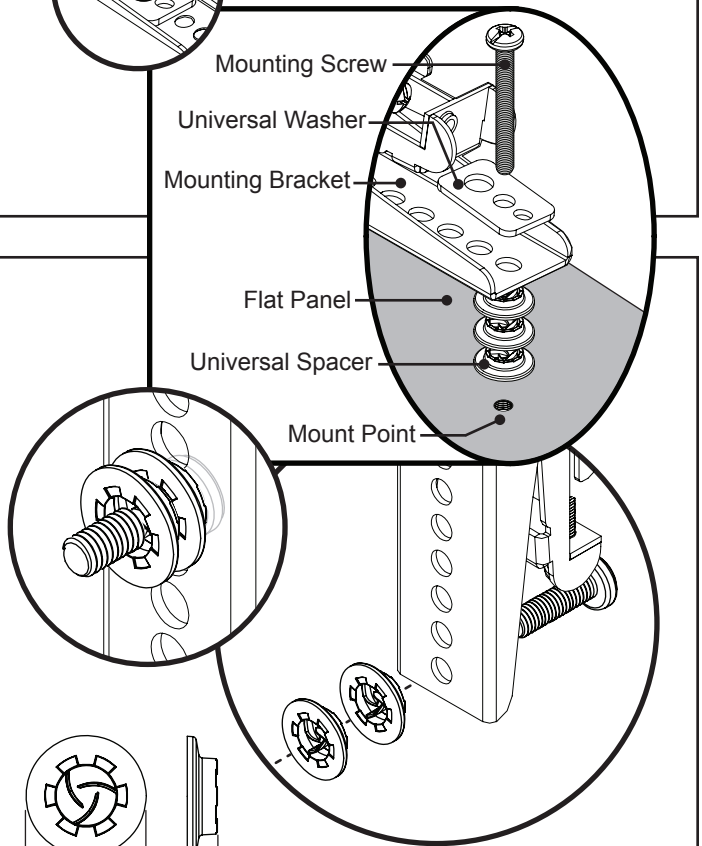
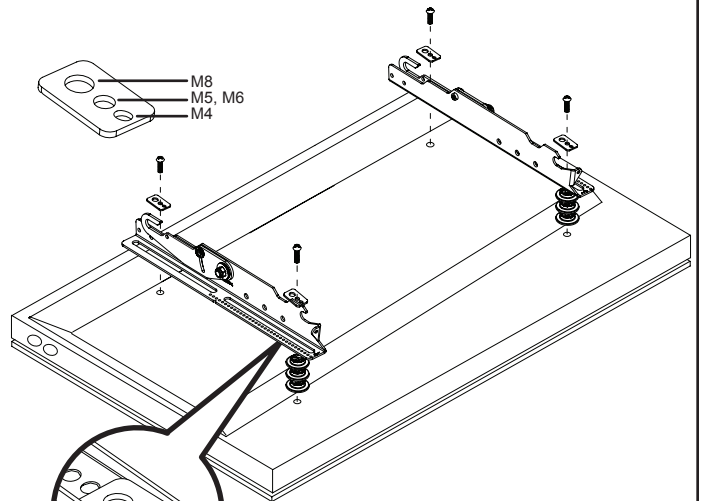

Universal Spacer Installation

Premier Mounts' Universal Spacers allow you to attach the mounting bracket to flat panels which have recessed or uneven mount points. Each Universal Spacer adds 1/4" to the distance between the mounting bracket and the flat panel.



The Universal Spacers must be stacked and oriented as shown.



The Universal Spacers must only be installed between the mounting bracket and the flat panel.

The Universal Spacers will fit M4, M5, M6 and M8 screw sizes.

Proceed to the "Attaching the Mounting Bracket to the Flat Panel" section.

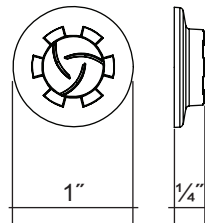



Installing the Mounting Brackets (cont'd)

Attaching the Mounting Brackets to the Flat Panel

This section presumes that you have read and understood these sections:

- Selecting the Proper Mounting Hardware
- Universal Washer Installation
- Universal Spacer Installation

- 1) Place your flat panel screen-side down on a soft, flat surface.
- 2) Identify the number and location of the thread inserts on the back of your flat panel.
- 3) Aligning the holes on each mounting bracket with the thread inserts on the back of your flat panel.
- 4) Secure each mounting bracket to your flat panel by inserting a minimum of two (2) screws per bracket.



Do not overtighten the mounting hardware.

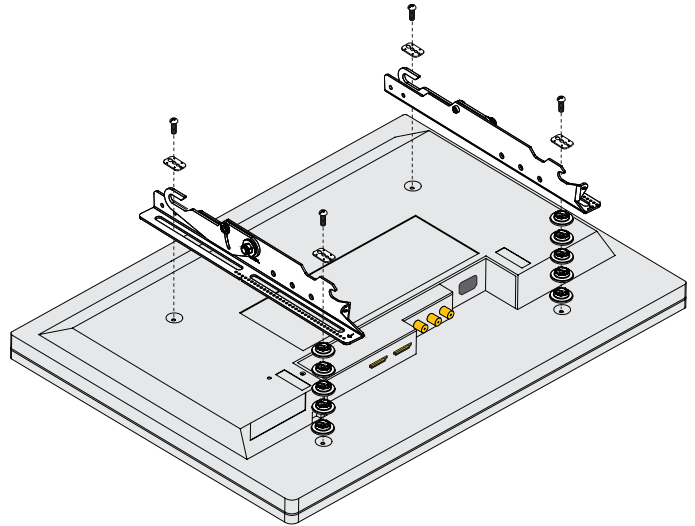

Proceed to the "Mounting the Flat Panel" below.

Mounting the Flat Panel

Attaching the Flat Panel to the Wall Plate



This section requires two people.



Do not release your flat panel until you are certain that top and bottom hooks of both mounting brackets are securely seated on the upper and lower mounting rails of the wall panel.

- 1) Raise the flat panel past the top and bottom mounting rails on the wall panel.
- 2) Slide the flat panel down slowly, keeping it close to the wall.
- 3) Engage the top and bottom mounting brackets to the rails of the wall plate.

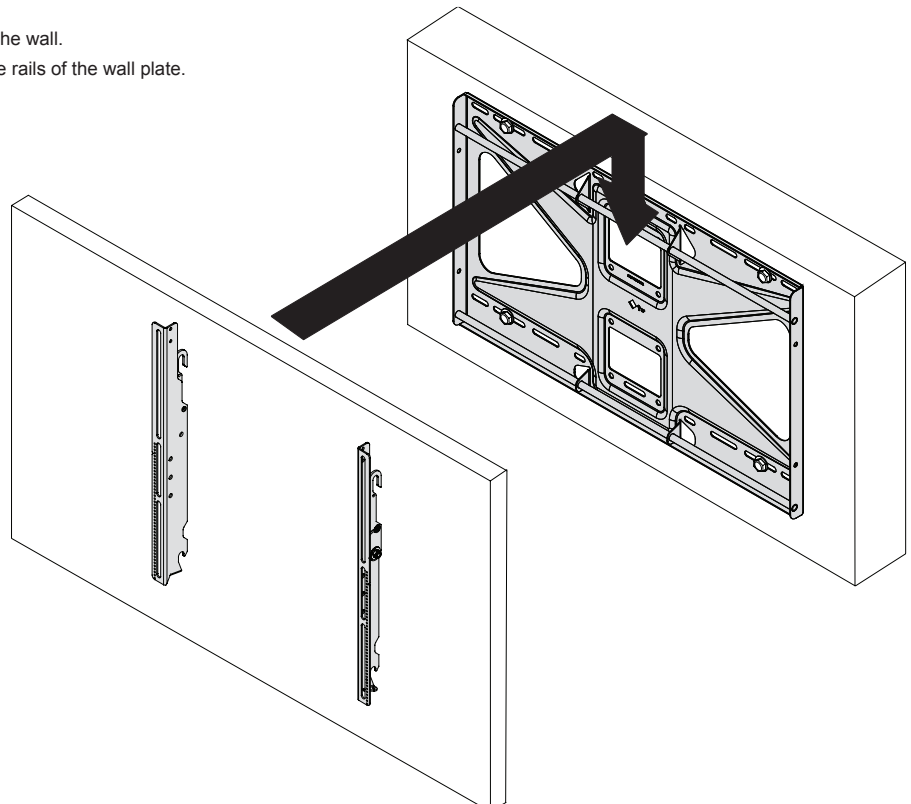
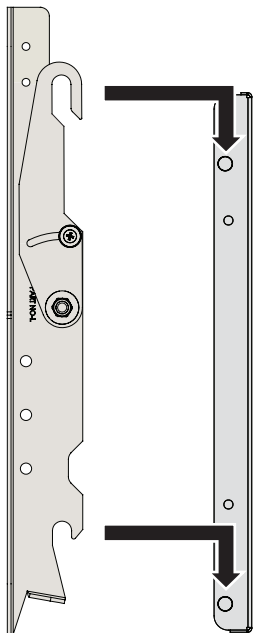



Safety Knurl Knob Installation



If you chose not to install the safety knurl knobs and instead chose to use the Panelock™, skip this section and proceed to the Panelock™ Installation section below.

The Panelock™ is a theft deterrent device. It comes with security hardware that requires a special tool that is used to install and remove the security head screws.



The safety knurl knobs keep the flat panel from being accidentally dislodged from the CTM-MS2.

- 1) Fully extend the flat panel away from the wall.
- 2) Install and tighten a safety knurl knob at the top of one of the mounting brackets.
- 3) Repeat steps 1 and 2 for the other safety knurl knob.

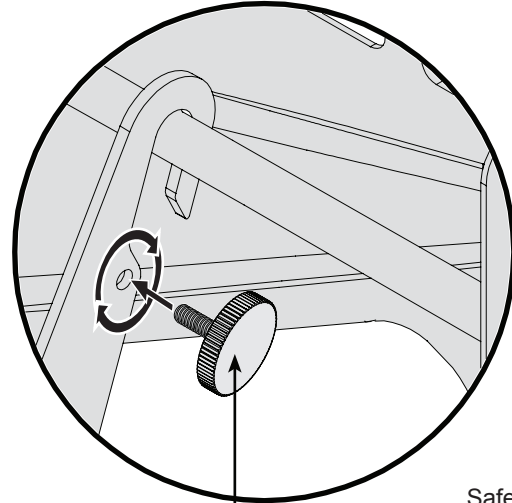

Safety Knurl Knob
(1 per Bracket)

Panelock™ Installation



If the safety knurl knobs were previously installed, they must be removed prior to installing the Panelock™ hardware.

- 1) Slide the Panelock™ onto the top mounting rail, placing the Panelock™ to the outside edge of the flat panel bracket.



Be sure that the Panelock™ is facing in the same direction as shown in the illustration to the right.

- 2) Insert and tighten one (1) M6 x 12mm screw to attach the Panelock™ to the flat panel bracket.



Repeat **1** and **2** to attach the remaining Panelock™.

Proceed to "Tilt Adjustment" on page 12.

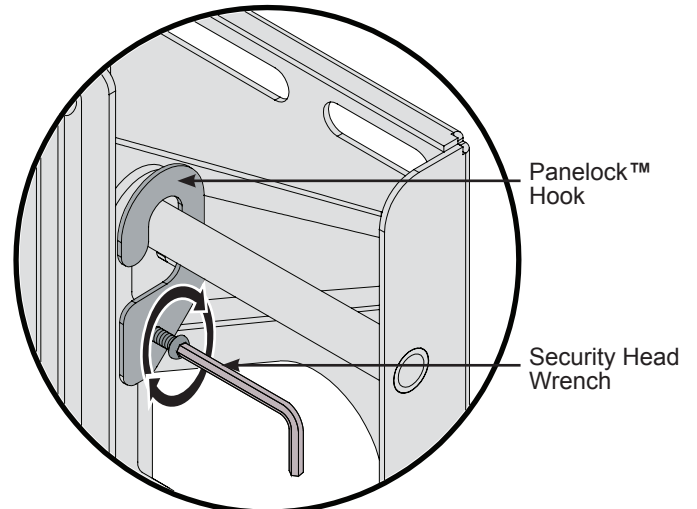
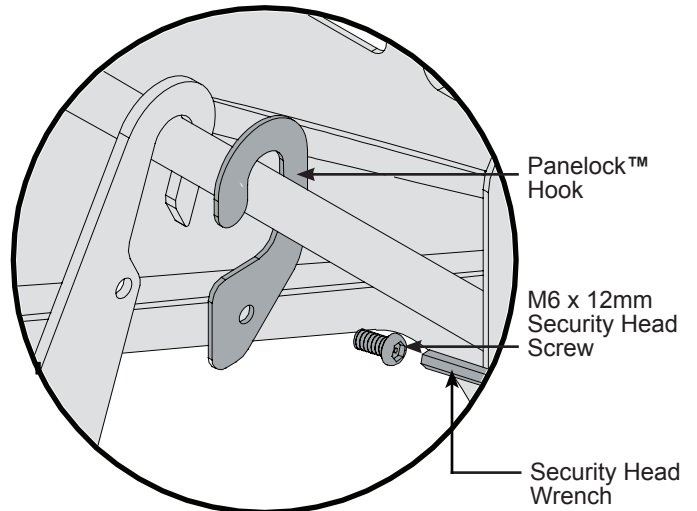



Locking Safety Screw Installation



The locking safety screws keep the flat panel from being accidentally dislodged from the CTM-MS2.

- 1) Thread an M6 x 30mm locking safety screw at the bottom of one of the mounting brackets.
- 2) Use a Phillips head screwdriver to tighten the locking safety screw.
- 3) Repeat steps 1 and 2 for the other locking safety screw.



Do not overtighten the locking safety screws.

Proceed to the "Installing the Mounting Bracket" below.

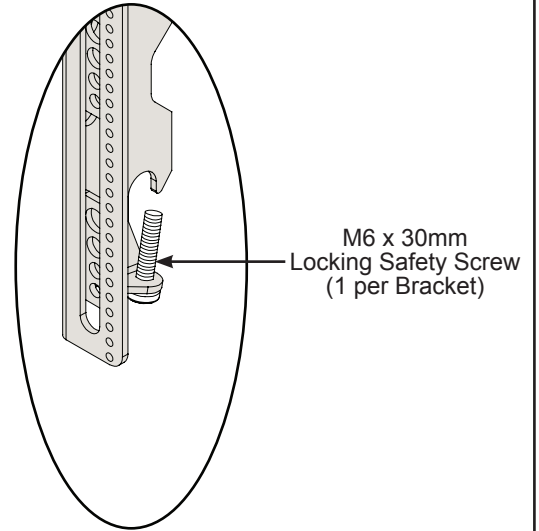

Tilt Adjustment

Adjusting the Flat Panel Friction Tilt Angle

- 1) Place one hand at the center top edge of the flat panel.
- 2) Place the other hand on the center bottom edge of the flat panel.
- 3) Using the upper hand, gently pull the top of the flat panel towards you while the lower hand gently pushes the bottom of the flat panel away from you.

Adjusting the Flat Panel to the Original Position

- 1) Place one hand at the center top edge of the flat panel.
- 2) Place the other hand on the center bottom edge of the flat panel.
- 3) Using the upper hand, gently push the top of the flat panel towards the wall while the lower hand gently pulls the bottom of the flat panel away from the wall.

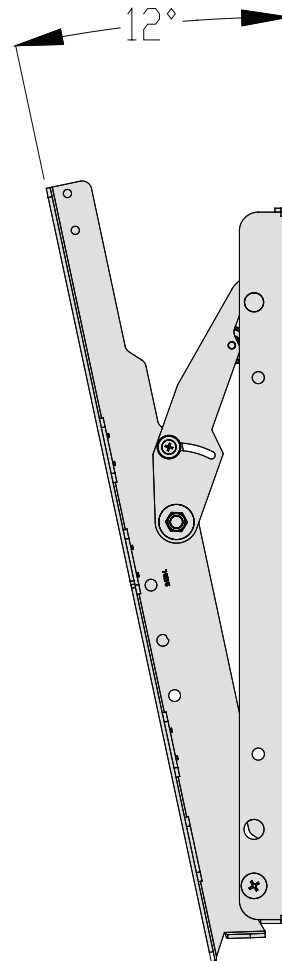

**PREMIER MOUNTS
LIMITED LIFETIME WARRANTY****What and Who is Covered by this Limited Warranty and for How Long**

Premier Mounts warrants this product to be free from defects in material and workmanship for the lifetime of the original owner of this product. The limited warranty is valid only for the original purchaser of the product.

What Premier Mounts Will Do

At the sole option of Premier Mounts, Premier Mounts will repair or replace any product or product part that is defective. If Premier Mounts chooses to replace a defective product or part, a replacement product or part will be shipped to you at no charge, but you must pay any labor costs.

What is Not Covered; Limitations

PREMIER MOUNTS DISCLAIMS ANY LIABILITY FOR DAMAGE TO MOUNTS, ADAPTERS, DISPLAYS, PROJECTORS, OTHER PROPERTY, OR PERSONAL INJURY RESULTING, IN WHOLE OR IN PART, FROM IMPROPER INSTALLATION, MODIFICATION, USE OR MISUSE OF ITS PRODUCTS.

NOTWITHSTANDING ANYTHING TO THE CONTRARY IN THIS WARRANTY, THIS WARRANTY IS LIMITED TO FIVE YEARS FROM THE DATE OF PURCHASE IN THE EVENT THAT THE WARRANTED PRODUCT IS COMMERCIALY RENTED OUT.

PREMIER MOUNTS DISCLAIMS ALL OTHER WARRANTIES, EXPRESS OR IMPLIED, INCLUDING WARRANTIES OF MERCHANTABILITY AND FITNESS FOR A PARTICULAR PURPOSE. PREMIER MOUNTS IS NOT RESPONSIBLE FOR INCIDENTAL OR CONSEQUENTIAL DAMAGES, INCLUDING BUT NOT LIMITED TO, INABILITY TO USE ITS PRODUCTS OR LABOR COSTS FOR REMOVING AND REPLACING DEFECTIVE PRODUCTS OR PARTS. SOME STATES DO NOT ALLOW THE EXCLUSION OR LIMITATION OF INCIDENTAL OR CONSEQUENTIAL DAMAGES, SO THE ABOVE LIMITATION OR EXCLUSION MAY NOT APPLY TO YOU.

What Customers Must Do for Limited Warranty Service

If you discover a problem that you think may be covered by the warranty you **MUST REPORT** it in writing to the address below within thirty (30) days. Proof of purchase (an original sales receipt) from the original consumer purchaser must accompany all warranty claims. Warranty claims must also include a description of the problem, the purchaser's name, address, and telephone number. General inquiries can be addressed to Premier Mounts Customer Service at 1-800-368-9700. Warranty claims will not be accepted over the phone or by fax.

Disclaimer

Attn: Warranty Claim
1321 S. State College Blvd.
Fullerton, CA 92831

How State Law Applies

THIS WARRANTY GIVES YOU SPECIFIC LEGAL RIGHTS, AND YOU MAY ALSO HAVE OTHER RIGHTS WHICH VARY FROM STATE TO STATE.

Premier Mounts intends to make this manual accurate and complete. However, Premier Mounts makes no claim that the information contained herein covers all details, conditions or variations, nor does it provide for every possible contingency in connection with the installation or use of this product. The information contained in this document is subject to change without notice or obligation of any kind. Premier Mounts makes no representation of warranty, expressed or implied, regarding the information contained herein. Premier Mounts assumes no responsibility for accuracy, completeness or sufficiency of the information contained in this document.



205 Westwood Ave, Long Branch, NJ 07740
Phone: 866-94 BOARDS (26273) / (732)-222-1511
Fax: (732)-222-7088 | E-mail: sales@touchboards.com