

CT2700A

40 kV High-Voltage DMM Probe

User Manual

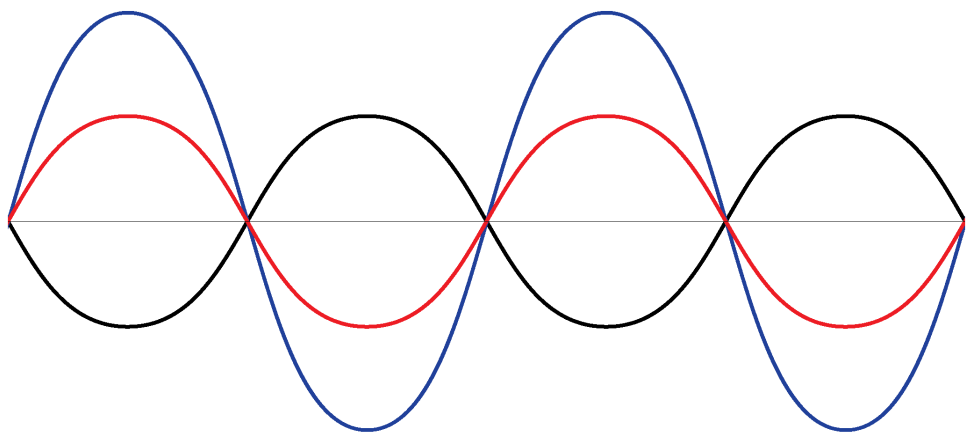

Notices

Copyright © 2023 Cal Test Electronics, Inc. All rights reserved.

Unauthorized duplication of this documentation material is strictly prohibited. Users are permitted to duplicate and distribute this documentation for internal educational purposes only. Cal Test Electronics is governed by United States and international copyright laws.

Made in Taiwan

User Manual Part Number

451-103-001

Available in electronic format only

Published by:

Cal Test Electronics, Inc.
22820 Savi Ranch Parkway
Yorba Linda, CA 92887 USA

Warranty

LIMITED ONE-YEAR WARRANTY

Cal Test Electronics, Inc warrants these products to be free from defective material or workmanship for a period of 1 year from the date of original purchase. Under this warranty, Cal Test Electronics, Inc is limited to repairing this product when returned to the factory, shipping charges prepaid, within the warranty period.

Units returned to Cal Test Electronics, Inc that have been subject to abuse, misuse, damage, or accident, or have been connected, installed, or adjusted contrary to the instructions furnished by Cal Test Electronics, Inc, or that have been repaired by unauthorized persons, will not be covered by this warranty.

Cal Test Electronics, Inc reserves the right to discontinue models, change specifications, price, or design of this device at any time without notice and without incurring any obligation whatsoever.

The purchaser agrees to assume all liabilities for any damages and/or bodily injury which may result from the use or misuse of this device by the purchaser, his employees, or agents.

THIS WARRANTY IS IN LIEU OF ALL OTHER REPRESENTATIONS OR WARRANTIES EXPRESSED OR IMPLIED AND NO AGENT OR REPRESENTATIVE OF CAL TEST ELECTRONICS, INC IS AUTHORIZED TO ASSUME ANY OTHER OBLIGATION IN CONNECTION WITH THE SALE AND PURCHASE OF THIS DEVICE.

Contents

Notices	2
User Manual Part Number	2
Warranty	2
Contents	3
Compliance Information	4
Safety	4
EC Declaration of Conformity - Low Voltage	4
Environmental	4
Restriction of Hazardous Substances (RoHS 2)	4
Terms & Symbols	5
Terms	5
Symbols	5
Safety Information	6
Usage Precautions	6
IEC Measurement Category & Pollution Degree Definitions	7
Introduction	8
Overview	8
Supplied Accessories	8
Using Accessories	9
Round Tip & Hook Tip	9
Flat Bar Tip	9
Measurement Instructions	10
Steps	10
Specifications	11
Cleaning	12
China RoHS 2	13
Hazardous Substances Disclosure Table	13

Compliance Information

Safety

EC Declaration of Conformity - Low Voltage

Compliance was demonstrated to the following specification as listed in the Official Journal of the European Communities: Low Voltage Directive: 2014/35/EU.

EN 61010-031:2015 Ed 2.0. Safety requirements for electrical equipment for measurement, control and laboratory use - Part 031: Safety requirements for hand-held probe assemblies for electrical measurement and test.

Environmental

Restriction of Hazardous Substances (RoHS 2)

The product and its accessories conform to the Directive 2011/65/EU (RoHS 2) on the restriction of the use of certain hazardous substances in electrical and electronic equipment, inclusive of any modification and addendum to said Directive.

EN ISO 63000:2018 Technical documentation for the assessment of electrical and electronic products with respect to the restriction of hazardous substances.



China RoHS 2 refers to the Ministry of Industry and Information Technology Order No. 32, effective July 1, 2015. See "Hazardous Substances Disclosure Table" on page 13.

Product End-of-Life Handling

The equipment may contain substances that could be harmful to the environment or human health if improperly handled at the product's end of life. To avoid release of such substances into the environment and to reduce the use of natural resources, we encourage you to recycle this product to an appropriate system that will ensure that most of the materials are reused or recycled appropriately.



This product is subject to Directive 2012/19/EU of the European Parliament and the Council of the European Union on waste electrical and electronic equipment (WEEE), and in jurisdictions adopting that Directive, is marked as being put on the market after August 13, 2005, and should not be disposed of as unsorted municipal waste. Please utilize your local WEEE collection facilities in the disposition of this product.

Terms & Symbols

The following terms, symbols, and definitions, individually or combination may appear on the product or in this user manual.

Terms

CAUTION A caution statement calls attention to an operating procedure, practice, or condition, which, if not followed correctly, could result in damage to or destruction of parts or the entire product.

WARNING A warning statement calls attention to an operating procedure, practice, or condition, which, if not followed correctly, could result in injury or death to personnel.

NOTE A note statement calls attention to an operating procedure, practice, or condition, which, should be noted before proceeding.

Symbols



CAUTION – Statements or instructions that must be consulted in order to find out the nature of the potential hazard and any actions which must be taken.



WARNING - HIGH VOLTAGE - possibility of electric shock.



The Conformité Européenne (CE) Mark is the European Union's (EU) mandatory conformity marking for regulating the goods sold within the European Economic Area (EEA).

Safety Information

Usage Precautions

WARNING The high-voltage probe is designed to prevent accidental shock to the operator when properly used. This operating note must be read and understood prior to using the probe. Improper procedure or incorrect analysis of the measurement situation can result in serious shock.

WARNING This high-voltage probe must only be used by personnel who are trained, experienced, or otherwise qualified to recognize hazardous situations and who are trained to the safety precautions that are necessary to avoid possible injury when using such a device.

WARNING This high-voltage probe is designed for use with Measurement Category *other than* II, III and IV only (formally CAT I). Do not use the probe for measurements performed on circuits defined by any other measurement category or transient overvoltages of more than 1500 V. Refer to IEC Measurement Category Definitions on page 7 for a definition of measurement categories.

WARNING The ground lead is critical to the safe operation of the probe. Failure to make this connection when making high-voltage measurements may result in personal injury or damage to the probe or oscilloscope. This connection must always be made **BEFORE** the probe tip comes in contact with the high voltage and must not be removed until the probe tip has been removed from the high-voltage source.



WARNING Hands, shoes, floor, and work bench must be dry. Avoid making measurements under humidity, dampness, or other environmental conditions that might affect safety.

WARNING To avoid injury, remove jewelry such as rings, watches, and other metallic objects. Do not touch exposed connections and components when power is present.

WARNING Do not work alone when working with high-Voltage Circuits.

WARNING The probe is designed to be used in office-type indoor environments.

- Do not operate in the presence of noxious, corrosive, flammable fumes, gases, vapors, chemicals, or finely-divided particulates.
- Hands, shoes, floor, and workbench must be dry. Avoid making measurements under humid, damp, or other environmental conditions that might effect the safety of the measurement situation.
- The probe body should be kept clean and free of any conductive contamination. Refer to the section on cleaning.

WARNING To reduce the risk of shock or fire:



- Connect the probe to the oscilloscope before connecting probe to the circuit under test. Disconnect the probe input from the circuit before disconnecting the probe from the oscilloscope.
- Do not exceed the voltage rating category rating of the probe. Use only accessories provided with probe.

-
- Keep finger behind the finger guard of the probe body.
 - For your own safety, inspect the probe for cracks and frayed or broken leads before each use. If defects are noted, DO NOT use the probe.
 - Keep the probe's output cables away from the circuit under test, as they are not intended to be in contact with these circuits.

WARNING It is advisable to turn the high-voltage source off before connecting or disconnecting the probe.

WARNING Do not attempt to take measurements where the source and the test instrument chassis or return lead is not properly grounded.

WARNING Do not connect the ground clip to the high voltage source or the probe tip to the ground for any reason.

IEC Measurement Category & Pollution Degree Definitions

Measurement Category (CAT) - classification of testing and measuring circuits according to the types of mains circuits to which they are intended to be connected.

Measurement Category *other than* II, III, or IV: circuits that are not directly connected to the mains supply.

Measurement Category II (CAT II): test and measuring circuits connected directly to utilization points (socket outlets and similar prints) of the low-voltage mains installation..

Measurement Category III (CAT III): test and measuring circuits connected to the distribution part of a building's low-voltage mains installation.

Measurement Category IV (CAT IV): test and measuring circuits connected at the source of the building's low-voltage mains installation.

Pollution - addition of foreign matter, solid, liquid, or gaseous (ionized gases) that may produce a reduction of dielectric strength or surface resistivity.

Pollution Degree 2 (P2)- only non-conductive pollution occurs except that occasionally a temporary conductivity caused by condensation is expected.

Introduction

Overview

The Cal Test CT2700A 40 kV High-Voltage Digital Multimeter (DMM) probe can be used with analog or digital multimeters (DMMs) which accept 4 mm sheathed banana plugs and have an input resistance of 10 M Ω ($\pm 1\%$). The CT2700A is a 1000:1 divider which extends the voltage measurement capability to 28 kV ACrms.

Features of the probe:

- Up to 40 kV (DC + ACpeak) or 28 kV ACrms
- 300 Hz bandwidth (-3dB)
- $\pm 3\%$ accuracy (20 kV to 40 kV)
- IEC/EN 61010-031



Figure 1 Probe and Supplied Accessories

Supplied Accessories

Table 1 CT4432 Accessory Replacements

Accessory	Model No.	Quantity
Round Tip	CT2960A	1
Hook Tip	CT2961A	1
Flat Bar Tip	CT2962A	1

Using Accessories

Round Tip & Hook Tip

Thread either the Round Tip or the Hook Tip onto the probe's M5 tip stud and securely hand-tighten.

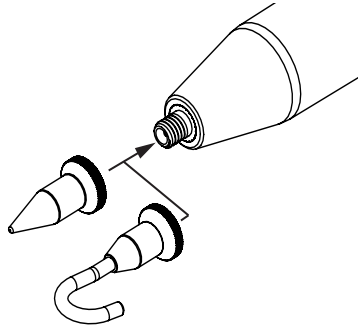

Figure 2 Attaching the Round and Hook Tips

Flat Bar Tip

The end of the Flat Bar Tip can be clamped to the device-under-test (DUT). To secure the Flat Bar Tip to the probe, use the supplied M5 flange nut (8 mm wrench or nut driver) as show in Figure 3.

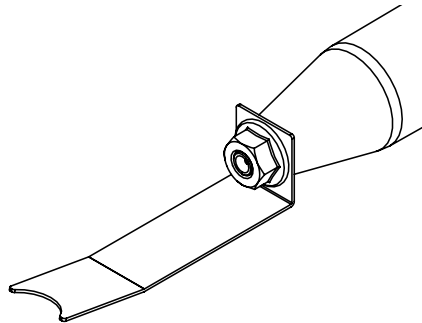

Figure 3 Attaching the Flat Bar Tip

Measurement Instructions



Before connecting the probe for your measurement, read all the warnings in this section and all of the warnings in the section “Safety Information” on page 6.

Steps

1. Whenever possible, turn off the high-voltage source before making any connections.
2. Connect the alligator ground clip lead to a good earth ground or reliable chassis ground.
3. Connect the probe's 4 mm sheathed banana plugs to the DMM's input jacks; Red to voltage jack and Black to COM jack.
4. On the DMM, select the voltage range.

CAUTION Do not use autoranging.

WARNING Before turning on the high voltage source, make sure that no part of the person holding the probe is touching the device under test.

5. After confirming that the probe operator is not touching the device under test, turn on the high-voltage source.
6. Measure the voltage readout on the DMM.

WARNING Remember the actual voltage is 1000 times greater than the DMM reading.

7. Turn off the high voltage source.
8. Disconnect the probe tip from the high-voltage source.
9. Disconnect the probe's ground clip lead.

WARNING Disconnect the probe tip from the high voltage source BEFORE disconnecting the alligator ground clip lead.

Specifications

All specifications apply to the probe after a temperature stabilization time of 15 minutes over an ambient temperature range of 25°C ±5°C.

NOTE All entries included in the following tables are characteristics unless otherwise stated.

Table 2 Safety Specifications

Parameter	Condition
IEC/EN 61010-031:2015	Measurement Category <i>other than</i> II, III, or IV (formally CAT I)

Table 3 Electrical Specifications (Not Warranted)

Parameter	Characteristic
Maximum Input Voltage	40 kV (DC + AC peak) 28 kV ACrms
Maximum Loading Current	≤40 μA (at 40 kV DC)
Division Ratio	1000:1
Bandwidth	DC to 300 Hz (-3 dB)
Input Resistance	1000 MΩ
VDC Accuracy	±1% (<20 kV) ±3% (20 kV to 40 kV) ≤0.5% (with 10 MΩ input impedance DMM only)
VAC Accuracy	5% at 60 Hz (1 to 28 kV)
Temperature Coefficient	≤200 ppm/°C
Maximum Loading Power	≤1.6 W
Source Impedance	10 MΩ

Table 4 Mechanical Specifications

Parameter	Characteristic
Cable & Lead Lengths	1 m (39")
Operating Temperature	0°C to 50°C (32°F to 122°F)
Storage Temperature	-20°C to 70°C (-4°F to 158°F)
Humidity	≤ 80% RH @ 40°C (104°F)
Dimensions	340 mm length x 80 mm diameter
Weight	300 g (0.66 lb)
Pollution	Pollution Degree 2 (P2)

Cleaning

Clean only the exterior probe body and cables. Use a soft cotton cloth light moistened with a mild solution of detergent and water. Do not allow any portion of the probe to be submerged at any time.

WARNING Dry the probe thoroughly before attempting to make voltage measurements.

CAUTION Do not subject the probe to solvents or solvent fumes as these can cause deterioration of the probe body and cables.

China RoHS 2

Hazardous Substances Disclosure Table



China RoHS 2 refers to the Ministry of Industry and Information Technology Order No. 32, effective July 1, 2015, titled Management Methods for the Restriction of the Use of Hazardous Substances in Electrical and Electronic Products. To comply with China RoHS 2, we determined this product's Environmental Protection Use Period (EPUP) to be 25 years in accordance with the Marking for the Restricted Use of Hazardous Substances in Electronic and Electrical Products, SJ/T 11364.

中國 RoHS 2 指工業和信息化部令第 32 號，自 2015 年 7 月 1 日起生效，題為《電氣電子產品有害物質限制使用管理辦法》。為符合中國 RoHS 2，我們根據電子電氣產品有害物質限制使用標誌 SJ/T 11364 將本產品的環保使用期限 (EPUP) 確定為 25 年。

Part Name 零件名稱	Hazardous Substance 有害物質					
	Lead (Pb) 鉛	Mercury (Hg) 汞	Cadmium (Cd) 鎘	Hexavalent Chromium (Cr (VI)) 六價鉻	Polybrominated biphenyls (PBB) 多溴聯苯	Polybrominated diphenyl ethers (PBDE) 多溴二苯醚
Printed Circuit Board Assemblies 印刷電路板組件	X	O	O	O	O	O
Electrical Components 電氣元件	X	O	O	O	O	O
Metal Components 金屬部件	X	O	O	O	O	O
Plastic Components 塑料部件	O	O	O	O	O	O

This table is made per guidance of SJ/T 11364.
該表是根據 SJ/T 11364 的指南製作的。

O: Indicates that this hazardous substance contained in all of the homogeneous materials for the part is below the limit requirement in GB/T 26572.
O: 表示該有害物質在該部件的所有均質材料中的含量低於 GB/T 26572 中的限量要求。

X: Indicates that this hazardous substance contained in at least one of the homogeneous materials used for this part is above the limit requirement in GB/T 26572.
X: 表示該有害物質在用於該部件的至少一種均質材料中的含量高於 GB/T 26572 中的限量要求。



© Cal Test Electronics, Inc.
Electronic Format Only
Manual Part Number: 451-103-001
Revision: A

