

SKF Vibracon element selection sheet

Coloured cells to be filled out

Address information

Company	:	<input type="text"/>
Contact	:	<input type="text"/>
Phone	:	<input type="text"/>
E-mail	:	<input type="text"/>
Preference (metric / Imperial)	:	<input type="text"/>
Customer name	:	<input type="text"/>
Project name	:	<input type="text"/>
Class / Approval type	:	<input type="text"/>
Object	:	<input type="text"/>
Make / type / model	:	<input type="text"/>

Remarks:

Top View of object

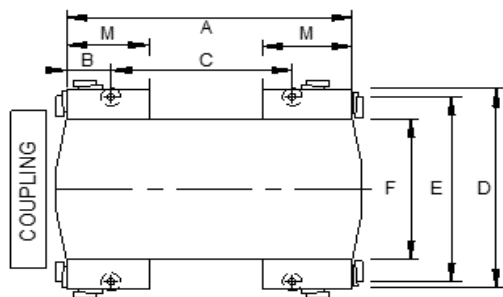

A	Total length of component base	:	<input type="text"/>	(inch)
B	Location first hole (seen from flexible coupling)	:	<input type="text"/>	(inch)
C	Pitch between other holes (on one side)	:	<input type="text"/>	(inch)
D	Total width of component base	:	<input type="text"/>	(inch)
E	Pitch of boltholes (left to right)	:	<input type="text"/>	(inch)
F	Foundation width (inside)	:	<input type="text"/>	(inch)
M	Foot length	:	<input type="text"/>	(inch)

Object overall information

Mass	:	<input type="text"/>	(lbs)
Power	:	<input type="text"/>	(kW)
Revolutions	:	<input type="text"/>	(rpm)
Number of foundation bolts	:	<input type="text"/>	(-)
Foundation bolthole diameter	:	<input type="text"/>	(inch)
Number of fitted bolts	:	<input type="text"/>	(-)
Fitted bolthole diameter	:	<input type="text"/>	(inch)

Additional info for gearbox applications:

- Reduction rate	:	<input type="text"/>	(-)
- Average distance between bolt holes	:	<input type="text"/>	(inch)
- Height shaft center line - Top plate of foundation	:	<input type="text"/>	(inch)
- Propulsion efficiency	:	<input type="text"/>	(N/kW)

Cross section of mounting detail

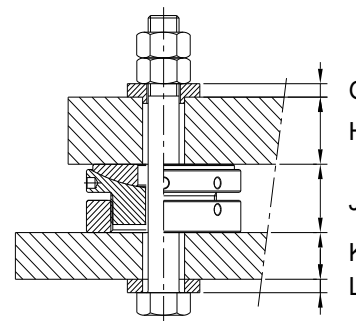

SKF recommends the use of a spherical washer in the bolt connection at position L:

- to compensate for angular errors;
- to increase the clamping length;
- eliminate bolt bending;
- to avoid spot facing.

SKF Spherical Washer	:	<input type="text"/>	(yes/no)
Bolt tightening from top	:	<input type="text"/>	(yes/no)

G	Top sleeve length foundation bolt	:	<input type="text"/>	(inch)
H	Bed plate thickness	:	<input type="text"/>	(inch)
J	Chock height	:	<input type="text"/>	(inch)
K	Top plate thickness	:	<input type="text"/>	(inch)
L	Bottom sleeve length foundation bolt	:	<input type="text"/>	(inch)
G	Top sleeve length fitted bolt	:	<input type="text"/>	(inch)
L	Bottom sleeve length fitted bolt	:	<input type="text"/>	(inch)