

INSTALLATION INSTRUCTIONS

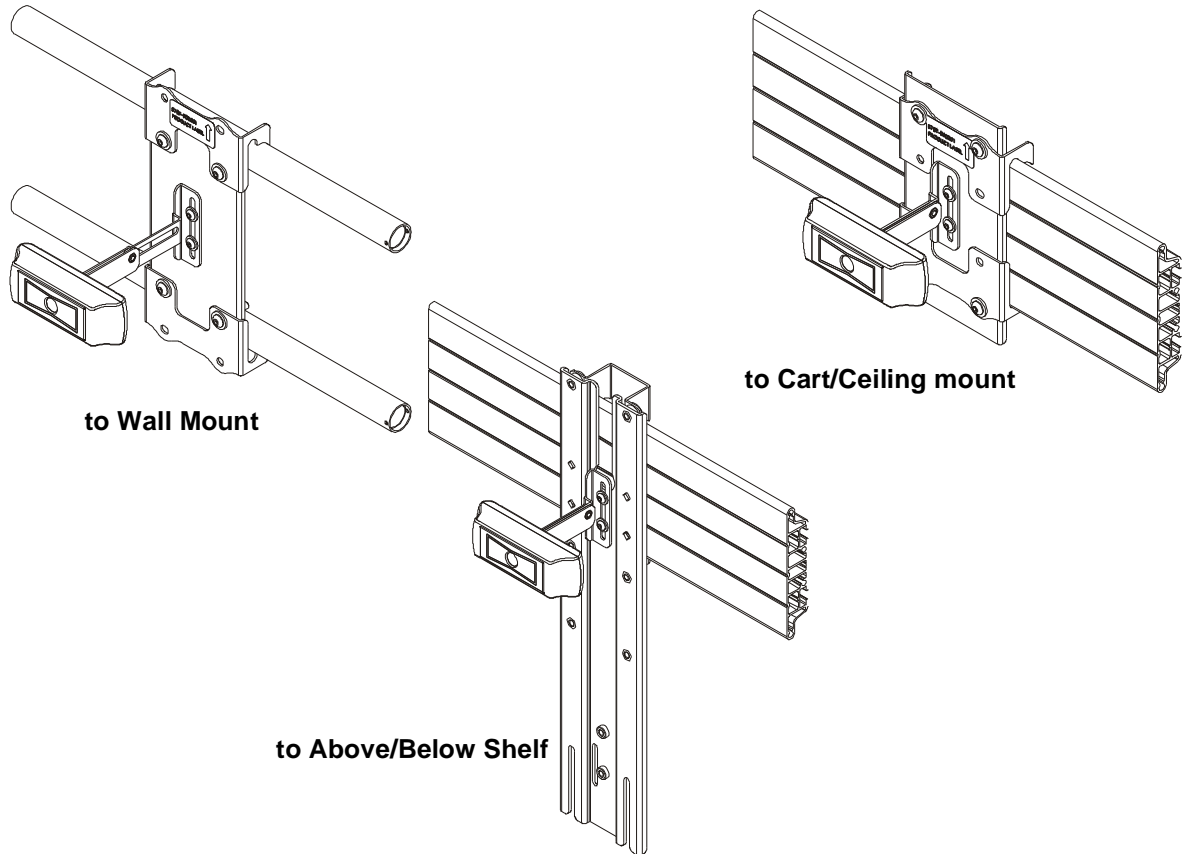

Fusion™ Center Accessory Shelf

Touchboards

205 Westwood Ave, Long Branch, NJ 07740
Phone: 866-94 BOARDS (26273) / (732)-222-1511
Fax: (732)-222-7088 | E-mail: sales@touchboards.com

CHIEF
Our Mounts. Your Vision.

FCA820V/VE

DISCLAIMER

Milestone AV Technologies and its affiliated corporations and subsidiaries (collectively "Milestone"), intend to make this manual accurate and complete. However, Milestone makes no claim that the information contained herein covers all details, conditions or variations, nor does it provide for every possible contingency in connection with the installation or use of this product. The information contained in this document is subject to change without notice or obligation of any kind. Milestone makes no representation of warranty, expressed or implied, regarding the information contained herein. Milestone assumes no responsibility for accuracy, completeness or sufficiency of the information contained in this document.

Chief® is a registered trademark of Milestone AV Technologies. All rights reserved.

IMPORTANT ! : Make sure the system meets the following requirements.

- Windows® 7, 8, 8.1 or higher
- Mac OS® X 10.7 or higher

With:

- 2.4GHz Intel® Core 2 Duo Processor
- 2GB RAM or more
- USB 2.0 port (USB 3.0 ready)

NOTE: Refer to milestone.com for the latest software compatibility requirements.

--SAVE THESE INSTRUCTIONS--



IMPORTANT SAFETY INSTRUCTIONS



WARNING: A WARNING alerts you to the possibility of serious injury or death if you do not follow the instructions.



CAUTION: A CAUTION alerts you to the possibility of damage or destruction of equipment if you do not follow the corresponding instructions.



WARNING: Failure to read, thoroughly understand, and follow all instructions can result in serious personal injury, damage to equipment, or voiding of factory warranty! It is the installer's responsibility to make sure all components are properly assembled and installed using the instructions provided.



WARNING: Use this mounting system only for its intended use as described in these instructions. Do not use attachments not recommended by the manufacturer.



WARNING: Never operate this mounting system if it is damaged. Return the mounting system to a service center for examination and repair.



WARNING: Do not use this product outdoors.



WARNING: RISK OF INJURY TO PERSONS! Do not use this mounting system to support video equipment such as televisions or computer monitors.

DIMENSIONS

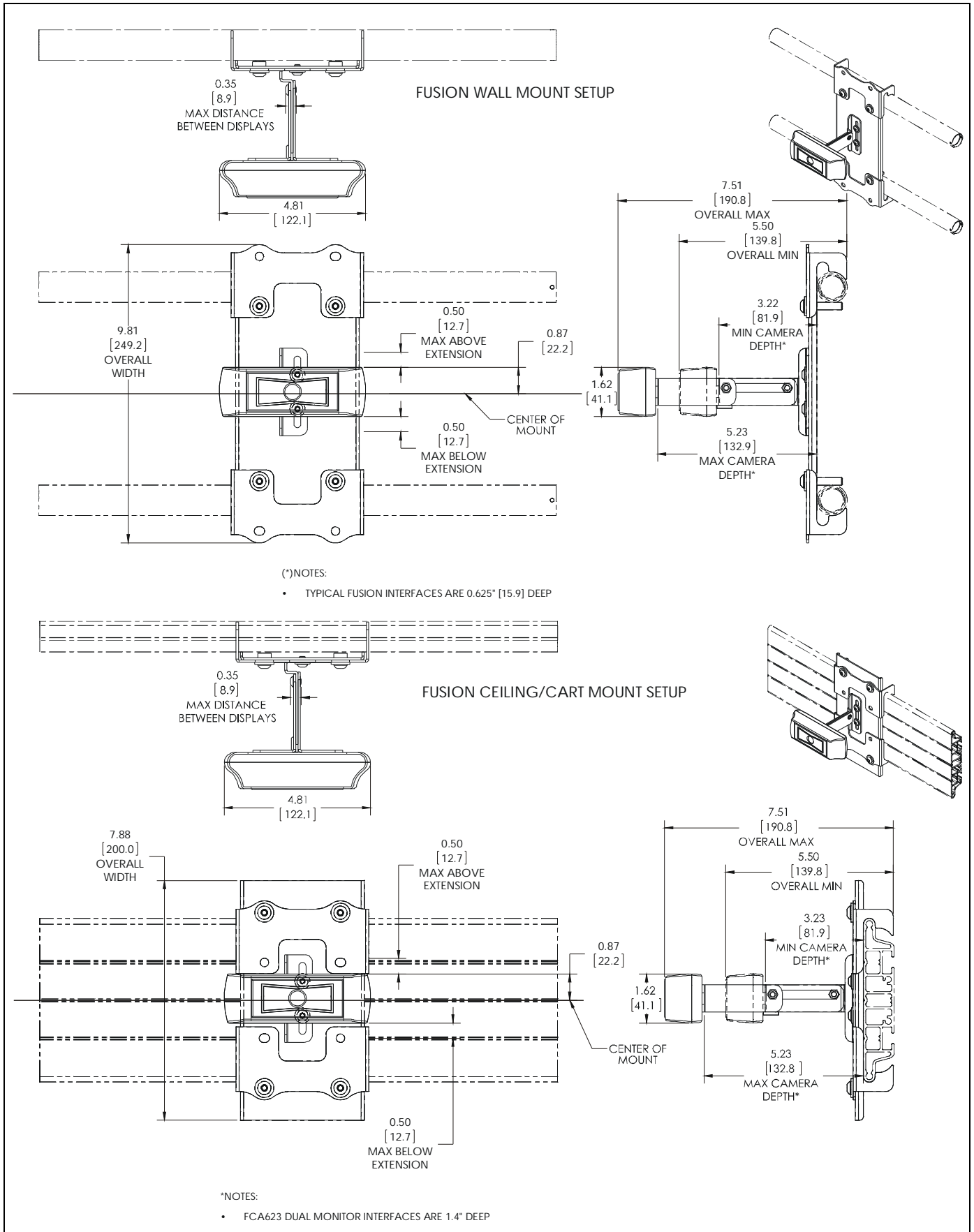

DIMENSIONS (CONTINUED)

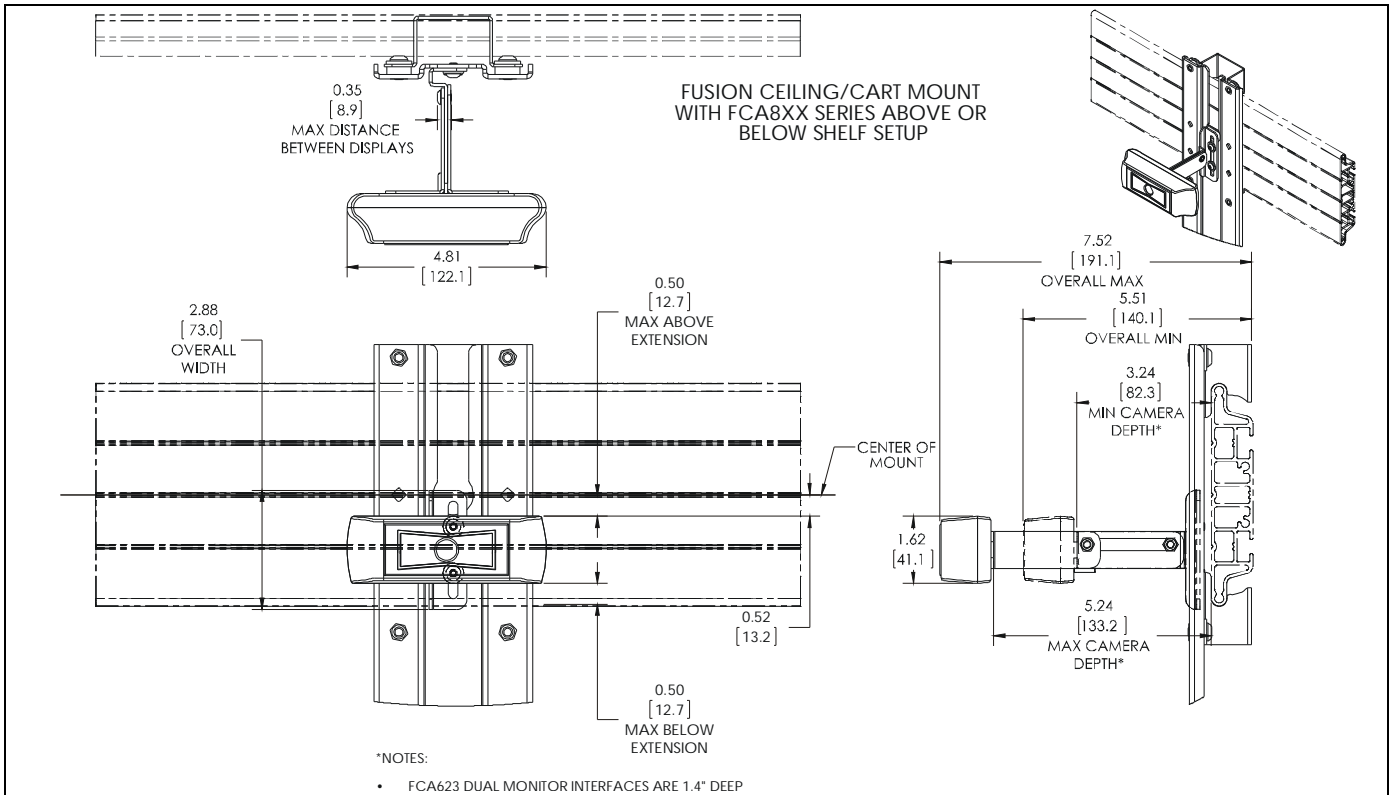

LEGEND

	Tighten Fastener	Apretar elemento de fijación		Phillips Screwdriver
	Befestigungsteil festziehen	Destornillador Phillips		
	Apertar fixador	Kreuzschlitzschraubendreher		
	Serrare il fissaggio	Chave de fendas Phillips		
	Bevestiging vastdraaien	Cacciavite a stella		
	Serrez les fixations	Kruiskopschroevendraaier		
	Loosen Fastener	Aflojar elemento de fijación		Open-Ended Wrench
	Befestigungsteil lösen	Llave de boca		
	Desapertar fixador	Gabelschlüssel		
	Allentare il fissaggio	Chave de bocas		
	Bevestiging losdraaien	Chiave a punte aperte		
	Desserrez les fixations	Steeksleutel		
	Hex-Head Wrench	Llave de cabeza hexagonal		Phillips Screwdriver
	Sechskantschlüssel	Destornillador Phillips		
	Chave de cabeça sextavada	Kreuzschlitzschraubendreher		
	Chiave esagonale	Chave de fendas Phillips		
	Zeskantsleutel	Cacciavite a stella		
	Clé à tête hexagonale	Kruiskopschroevendraaier		

TOOLS REQUIRED FOR INSTALLATION

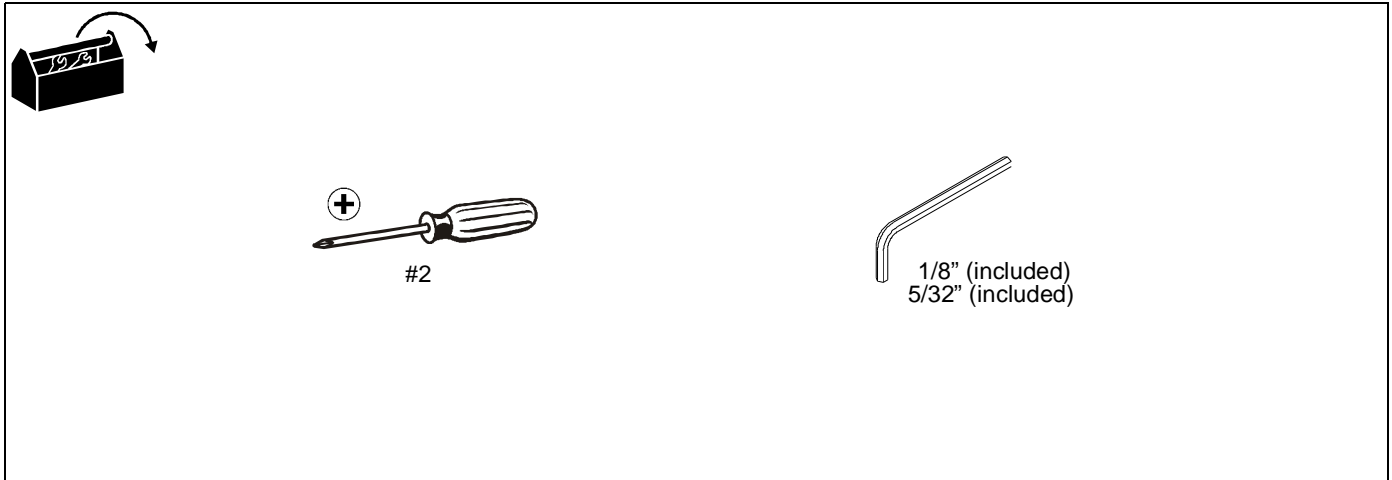

PARTS

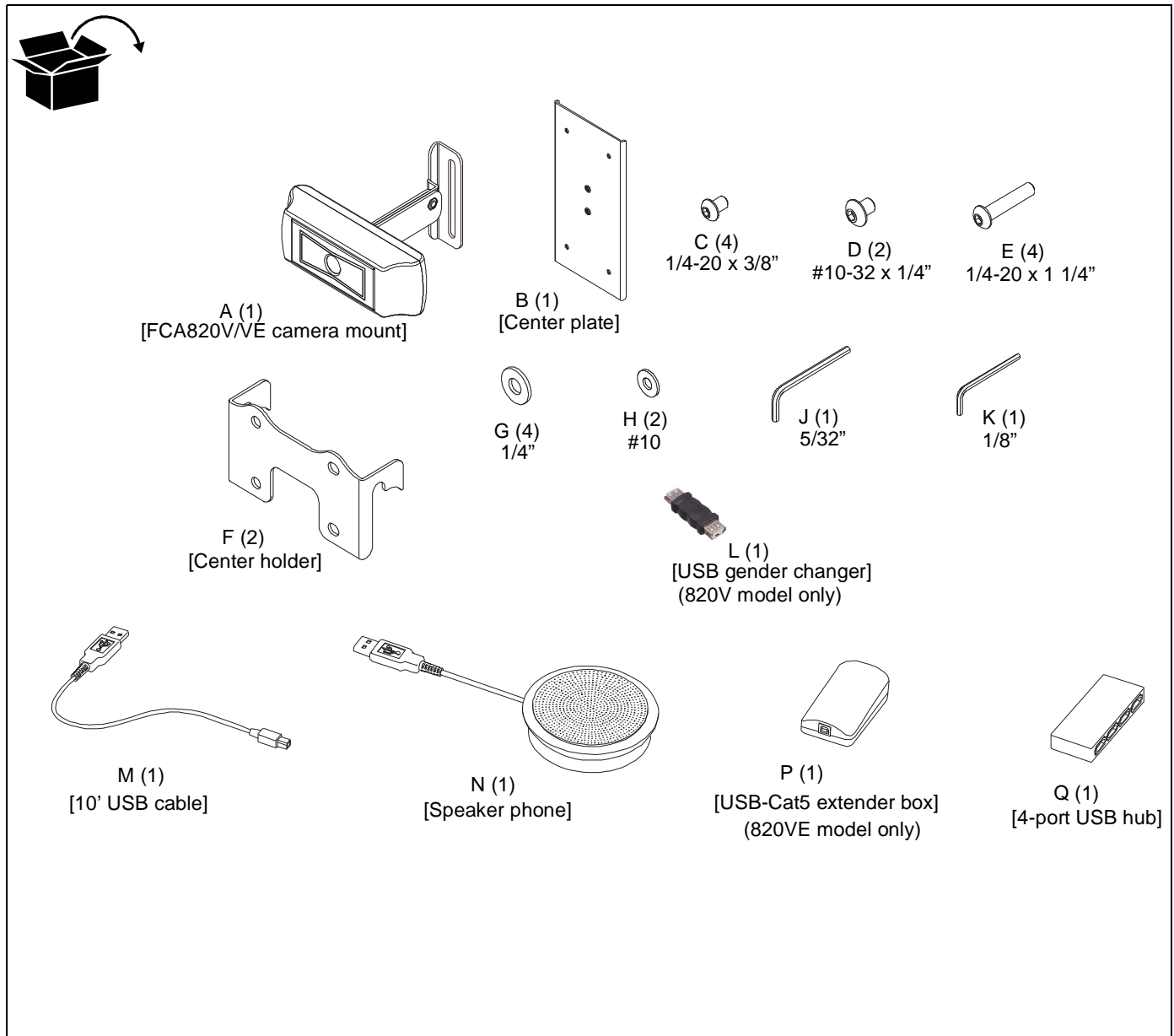

ASSEMBLY AND INSTALLATION

Installing to Cart/Ceiling Mount

NOTE: If installing to Wall Mount, proceed to "Installing to Wall Mount" Section. If installing to an FCA800/801 or FCA810/811 shelf, proceed to "Installing to FCA800/801/810/811 Shelves" section.

1. Attach FCA820V/VE camera mount (A) to center plate (B) using two #10-32 x 1/4" button head cap screws (D) and two #10 washers (H). (See Figure 1)

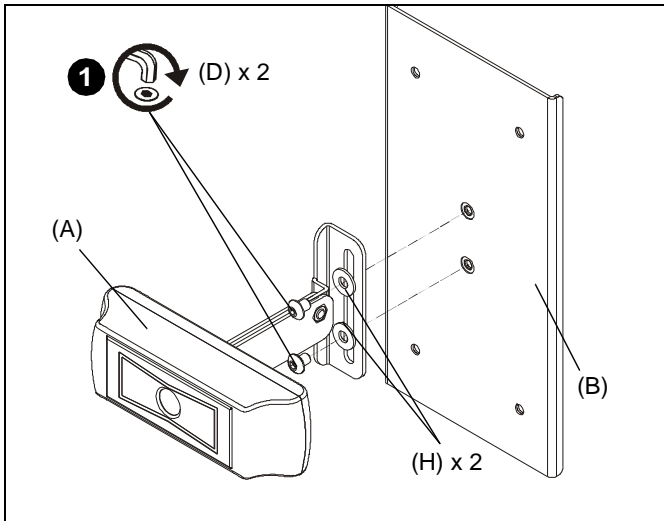

Figure 1

2. Use two 1/4-20 x 3/8" button head cap screws (C) and two 1/4" washers (G) to attach one center holder (F) to center plate (B). (See Figure 2)

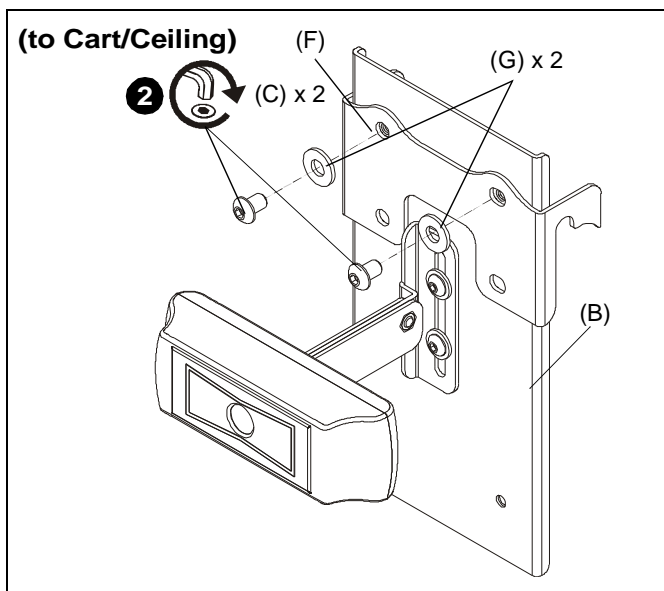

Figure 2

3. Place center holder (F) on top of cart interface. (See Figure 3)
4. Place second center holder (F) underneath cart interface so that mounting holes are aligned. (See Figure 3)

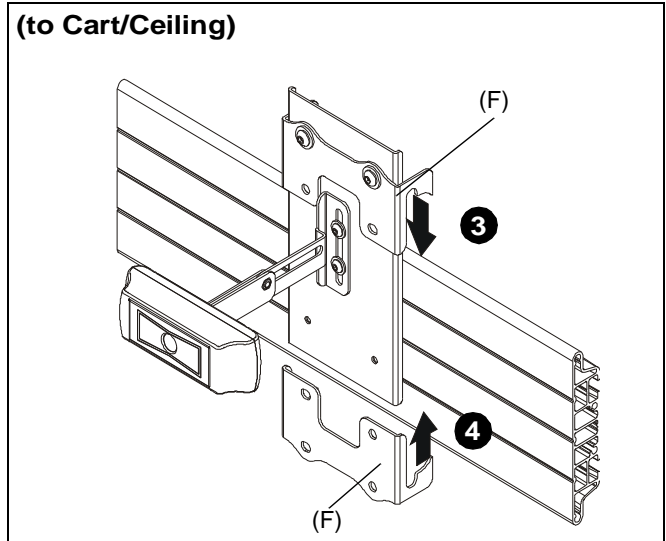

Figure 3

5. Use two 1/4-20 x 3/8" button head cap screws (C) and two 1/4" washers (G) to attach the other center holder (F) to center plate (B). (See Figure 4)

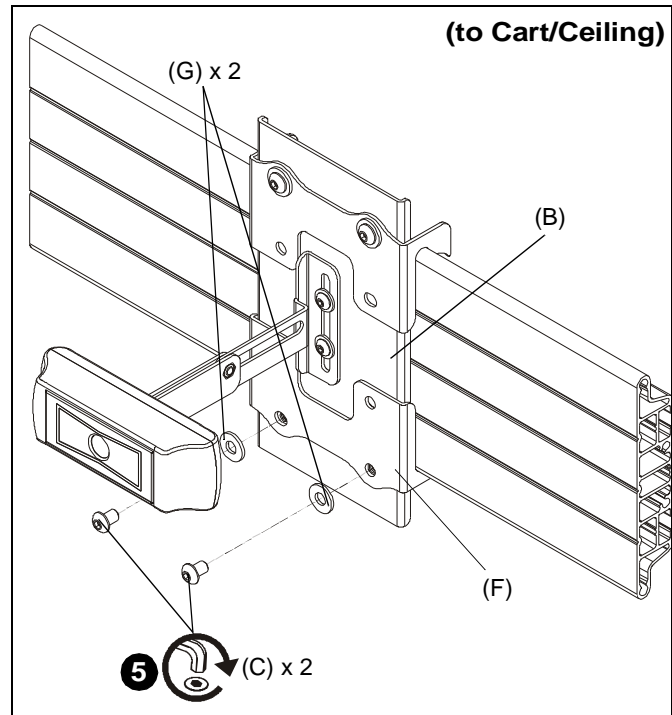

Figure 4

Installing to Wall Mount

1. Attach FCA820V/VE camera mount (A) to center plate (B) using two #10-32 x 1/4" button head cap screws (D) and two #10 washers (H). (See Figure 5)

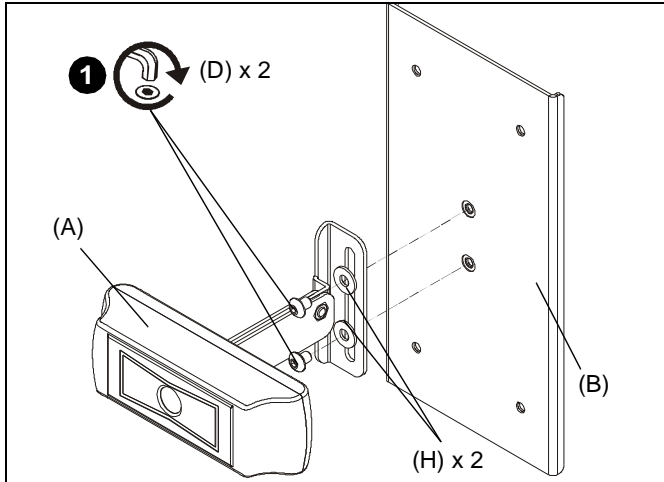

Figure 5

2. Use two 1/4-20 x 1 1/4" button head cap screws (E) and two 1/4" washers (G) to partially attach one center holder (F) to center plate (B). Do NOT install screws too far or installation to wall mount will not be possible. (See Figure 6)

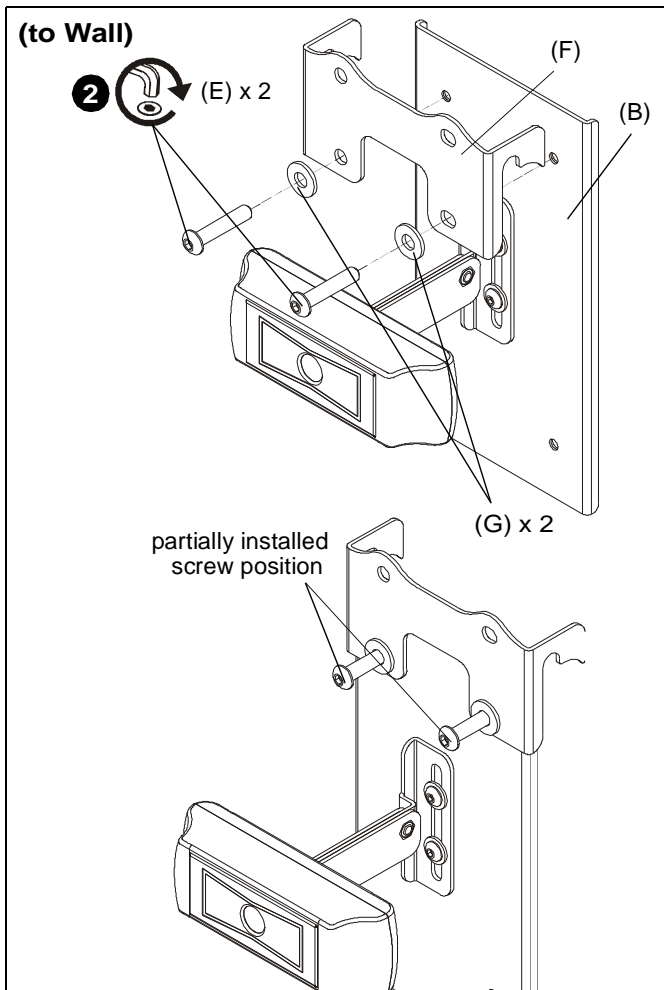

Figure 6

3. Place center holder (F) on top of wall mount rail. (See Figure 7)
4. Tighten two screws (E) holding center holder (F) to center plate (B). (See Figure 7)
5. Place second center holder (F) underneath wall mount rail so that mounting holes are aligned. (See Figure 7)

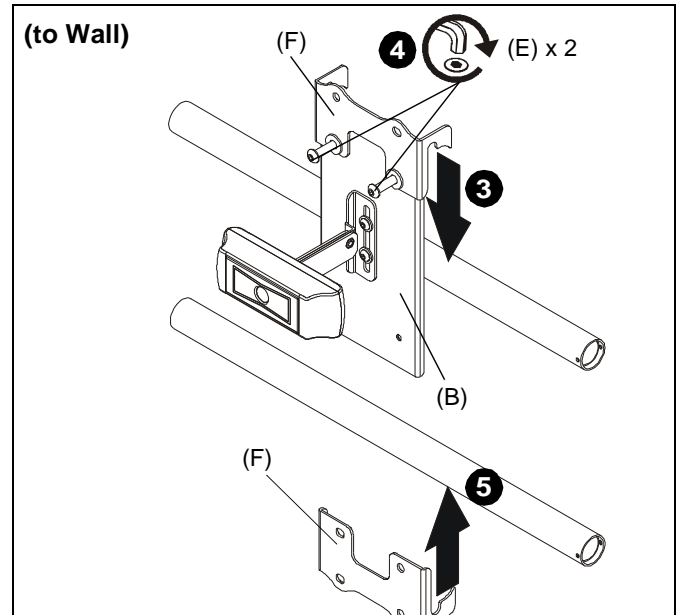

Figure 7

6. Use two 1/4-20 x 1 1/4" button head cap screws (E) and two 1/4" washers (G) to attach the other center holder (F) to center plate (B). (See Figure 8)

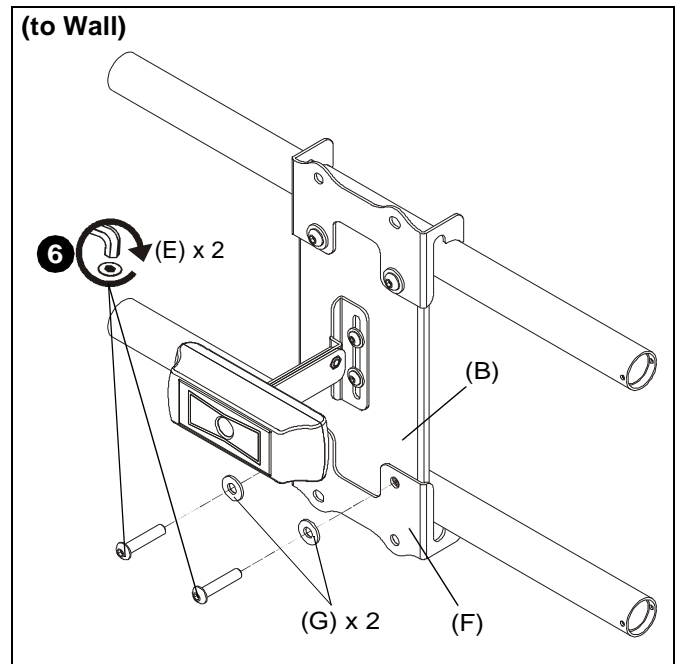

Figure 8

Installing to FCA800/801/810/811 Shelves

NOTE: FCA820V/VE may be attached to FCA800/801 or FCA810/811 Above/Below Shelves.

1. Install FCA shelf to mount following FCA shelf installation instructions.
2. Use two #10-32 x 1/4" button head cap screws (D) and two #10 washers (H) to secure FCA820V/VE camera mount (A) to FCA shelf main bracket. (See Figure 9)

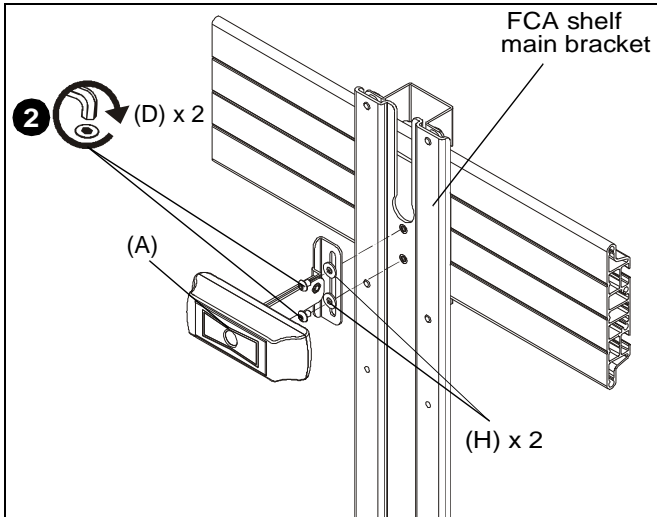

Figure 9

Camera Height Adjustment

1. Loosen two screws (D) holding camera mount (A) to center plate (B). (See Figure 10)
2. Adjust camera height to desired height. (See Figure 10)
3. Tighten two screws (D) holding camera mount (A) to center plate (B). (See Figure 10)

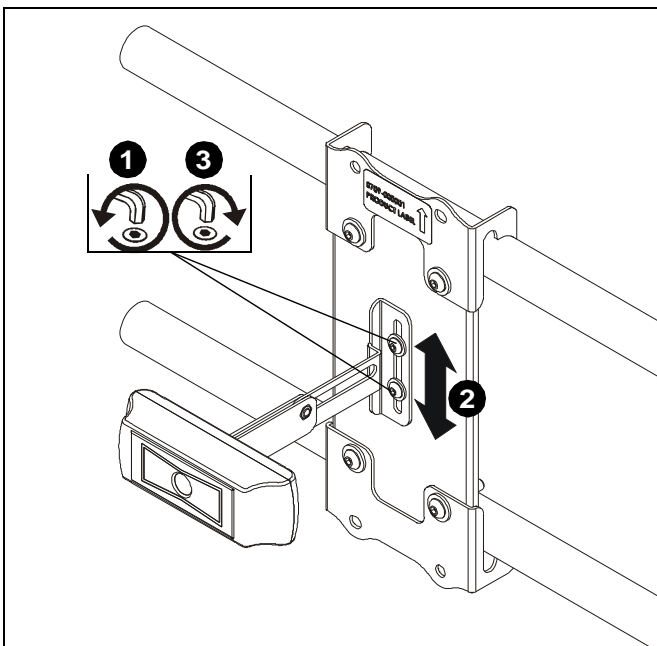

Figure 10

Viewshare Installation

NOTE: Refer to milestone.com for the latest software compatibility requirements.

FCA820V

1. Connect camera to USB gender changer (BB) using USB cable supplied with camera. (See Figure 35)
2. Connect USB gender changer (BB) to 4-port USB hub (FF) using 10' USB cable (CC). (See Figure 35)
3. Connect speaker phone (DD) to 4-port USB hub (FF) using USB cable supplied with speaker phone. (See Figure 35)
4. Plug in 4-port USB hub (FF) to power source. (See Figure 35)
5. Connect 4-port USB hub (FF) to computer using USB cable included with hub. (See Figure 35)
6. Connect computer to display or projector. (See Figure 35)
7. Verify the correct audio and video sources are selected in computer's settings (PC) or preferences (Mac). The camera will show up as "Logitech Webcam C930e."
8. Download latest version of Skype or comparable video conferencing application.

FCA820VE

1. Connect camera to USB extender box (EE) using USB cable supplied with camera. (See Figure 35)
2. Connect USB extender box (EE) to second USB extender box using CAT5 cable (not included). (See Figure 35)
3. Connect second USB extender box to 4-port USB hub (FF) using USB cable (CC). (See Figure 35)
4. Connect speaker phone (DD) to 4-port USB hub (FF) using USB cable supplied with speaker phone (DD). (See Figure 35)
5. Plug in 4-port USB hub (FF) to power source. (See Figure 35)
6. Connect 4-port USB hub (FF) to computer using USB cable included with hub. (See Figure 35)
7. Connect computer to display or projector. (See Figure 35)
8. Verify the correct audio and video sources are selected in computer's settings (PC) or preferences (Mac). The camera will show up as "Logitech Webcam C930e."
9. Download latest version of Skype or comparable video conferencing application.

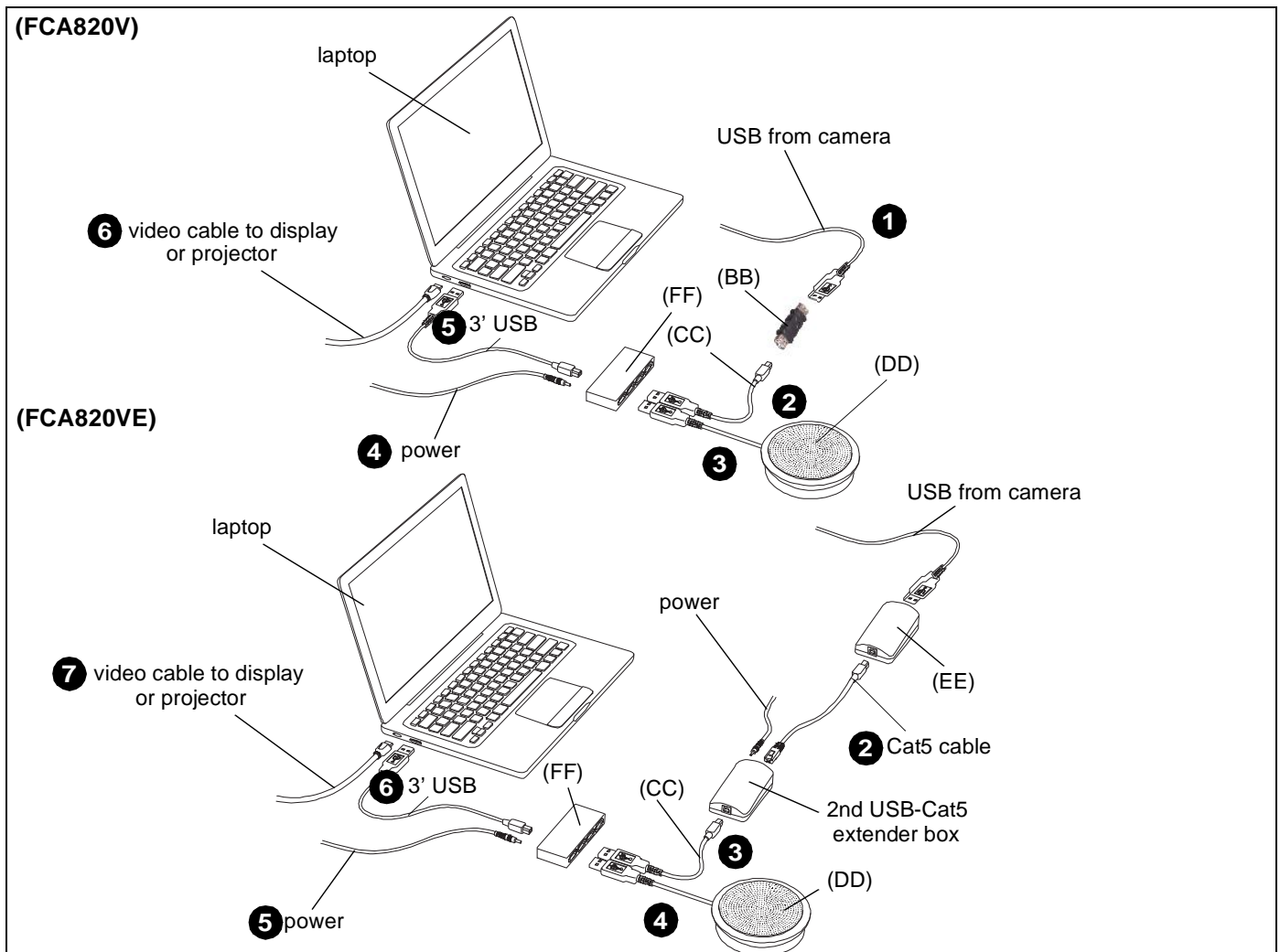

Figure 11

Touchboards

205 Westwood Ave, Long Branch, NJ 07740
 Phone: 866-94 BOARDS (26273) / (732)-222-1511
 Fax: (732)-222-7088 | E-mail: sales@touchboards.com



Our Mounts. **Your Vision.**

Chief, a products division of
 Milestone AV Technologies

8800-002733 Rev00
 ©2015 Milestone AV Technologies
www.chiefmfg.com
 08/15

USA/International	A 6436 City West Parkway, Eden Prairie, MN 55344
	P 800.582.6480 / 952.225.6000
	F 877.894.6918 / 952.894.6918
Europe	A Franklinstraat 14, 6003 DK Weert, Netherlands
	P +31 (0) 495 580 852
	F +31 (0) 495 580 845
Asia Pacific	A Office No. 918 on 9/F, Shatin Galleria 18-24 Shan Mei Street Fotan, Shatin, Hong Kong
	P 852 2145 4099
	F 852 2145 4477

