

INSTALLATION INSTRUCTIONS

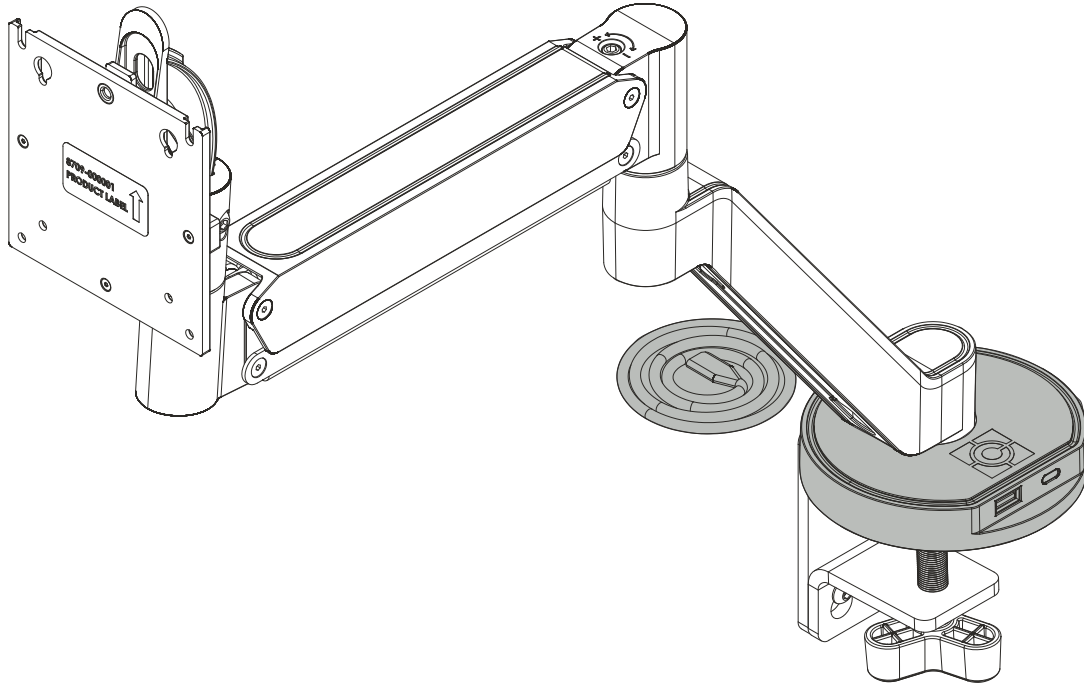

Koncis™ Integrated Power Base

DISCLAIMER

Legrand | AV and its affiliated corporations and subsidiaries (collectively "Legrand | AV"), intend to make this manual accurate and complete. However, Legrand | AV makes no claim that the information contained herein covers all details, conditions or variations, nor does it provide for every possible contingency in connection with the installation or use of this product. The information contained in this document is subject to change without notice or obligation of any kind. Legrand | AV makes no representation of warranty, expressed or implied, regarding the information contained herein. Legrand | AV assumes no responsibility for accuracy, completeness or sufficiency of the information contained in this document.

Chief® is a registered trademark of Legrand AV Inc.

DEFINITIONS

MOUNTING SYSTEM: A MOUNTING SYSTEM is the primary Chief product to which an accessory and/or component is attached.

ACCESSORY: AN ACCESSORY is the secondary Chief product which is attached to a primary Chief product, and may have a component attached or setting on it.

COMPONENT: A COMPONENT is an audiovisual item designed to be attached or resting on an accessory or mounting system such as a video camera, CPU, screen, display, projector, etc.

 **WARNING** alerts you to the possibility of serious injury or death if you do not follow the instructions.

 **CAUTION** alerts you to the possibility of damage or destruction of equipment if you do not follow the corresponding instructions.

 **IMPORTANT SAFETY INSTRUCTIONS**

 **WARNING:** FAILURE TO READ AND FOLLOW THE FOLLOWING INSTRUCTIONS CAN RESULT IN SERIOUS PERSONAL INJURY, DAMAGE TO EQUIPMENT OR VOIDING OF FACTORY WARRANTY. It is the installer's responsibility to make sure all components are properly assembled and installed using the instructions provided.

IMPORTANT ! : Model D1U/D2U is suitable for use in Other Environmental Air Space in Accordance with Section 300.22(C) of the National Electrical Code.

When using an electrical mounting system, basic precautions should always be followed, including the following:

READ ALL INSTRUCTIONS BEFORE USING THIS PRODUCT!!!!

 **DANGER:** TO REDUCE THE RISK OF ELECTRIC SHOCK:

1. Always turn off power at source before cleaning.

 **WARNING:** TO REDUCE THE RISK OF BURNS, FIRE, ELECTRIC SHOCK, OR INJURY TO PERSONS:

- Always turn off power at source before putting on or taking off parts.
- Use this accessory only for its intended use as described in these instructions. Do NOT use attachments not recommended by the manufacturer.
- Never operate this accessory if it has a damaged test cord or test plug. If it is not working properly during testing, return the accessory to a service center for examination and repair.
- Keep the test power cord away from heated surfaces.
- Never operate the accessory with the air openings blocked. Keep the air openings free of lint, hair, and the like.
- Never drop or insert any object into any opening.
- Do not use outdoors unless marked for outdoor use.
- Route cords and cables as shown in the installation instructions.
- To disconnect, turn all controls to the off position, then turn off power at source.

 **WARNING:** RISK OF ELECTRIC SHOCK!
Connect this accessory to a properly grounded outlet only.

 **WARNING:** Do NOT exceed the following power ratings for the outlets on this accessory:

- One USB type "A", one USB type "C": 5Vdc, 3.1A/ 15W (shared)

This device complies with Part 15 of the FCC Rules. Operation is subject to the following two conditions: (1) This device may not cause harmful interference, and (2) this device must accept any interference received, including interference that may cause undesired operation.

 **WARNING:** Changes or modifications to this unit not expressly approved by the manufacturer can void the units FCC compliance rating and make the unit illegal to operate.

NOTE: This equipment has been tested and found to comply with the limits for a Class B digital device, pursuant to Part 15 of the FCC rules. These limits are designed to provide reasonable protection against harmful interference in a residential installation. This equipment generates, uses and can radiate radio frequency energy and, if not installed and used in accordance with the instructions, may cause harmful interference to radio communications. However, there is no guarantee that interference will not occur in a particular installation. If this equipment does not cause harmful interference to radio or television reception, which can be determined by turning the equipment off and on, the user is encouraged to try to correct the interference by one or more of the following measures:

- Reorient or relocate the receiving antenna.

- Increase the separation between the equipment and receiver.
- Connect the equipment into an outlet on a circuit different from that to which the receiver is connected.
- Consult the dealer or an experienced radio/TV technician for help.

Responsible Party:

Legrand | AV
 6436 City West Parkway
 Eden Prairie, MN 55344
 866-977-3901
 av.support@legrand.com
 CAN ICES-3 (B)/NMB-3(B)

 This system has no user serviceable parts.

--SAVE THESE INSTRUCTIONS--

DIMENSIONS

D1U

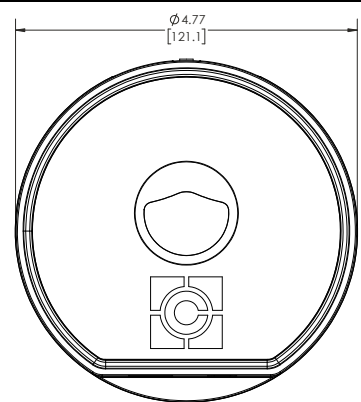
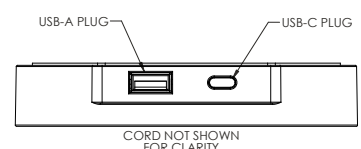
CORD NOT SHOWN FOR CLARITY

NOTES:

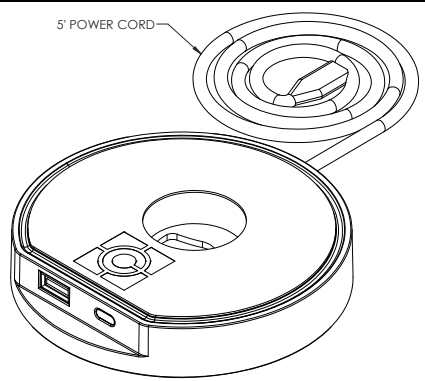
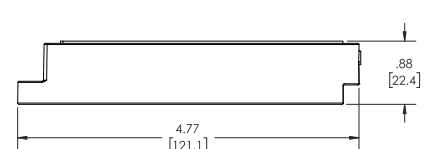
- USB-A AND USB-C PORTS SUPPORT SHARED 3A OF DEVICE CHARGING.
- 1-PORT USB-C WALL CHARGER WITH POWER DELIVERY, 18W (INCLUDED BUT NOT SHOWN)

D2U

CORD NOT SHOWN FOR CLARITY

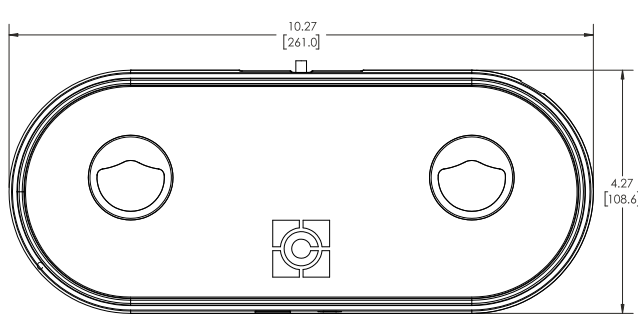
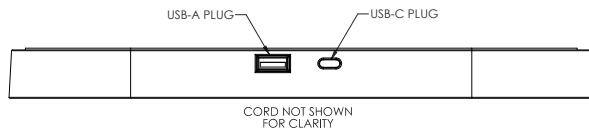
NOTES:

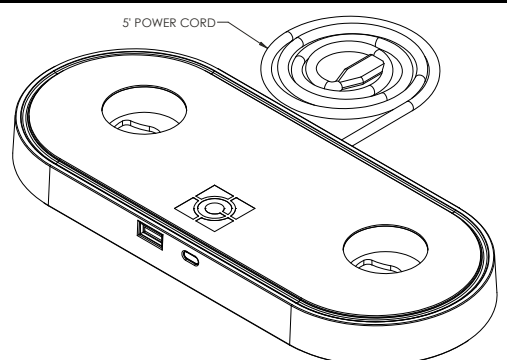
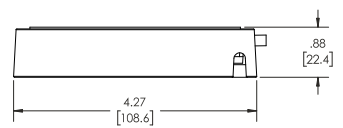
- USB-A AND USB-C PORTS SUPPORT SHARED 3A OF DEVICE CHARGING.
- 1-PORT USB-C WALL CHARGER WITH POWER DELIVERY, 18W (INCLUDED BUT NOT SHOWN)

PARTS

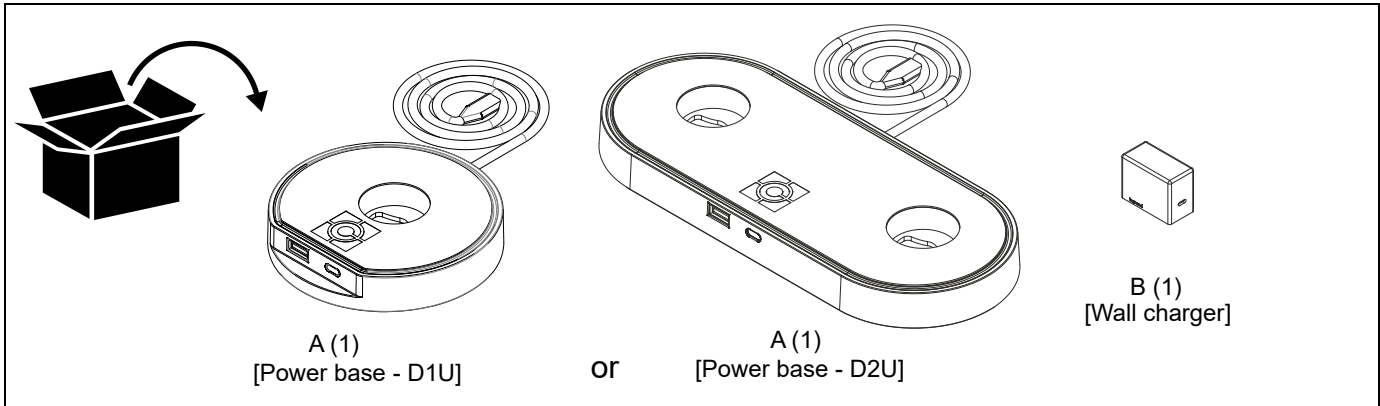

Assembly And Installation

1. Remove Koncis™ mount arm(s) from mount base.
2. Remove cover from top of mount base. (See Figure 1)

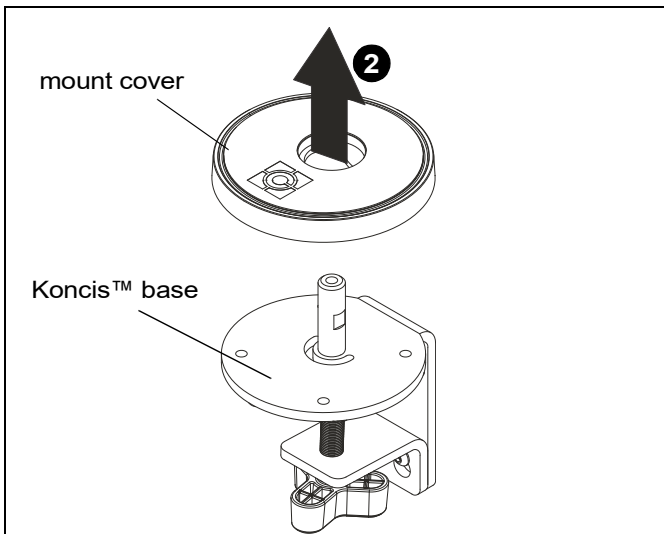

Figure 1

3. Install power base (A) to mount base by placing it over the pin of the mount base. (See Figure 2)
4. Place removed arm onto power base by placing it over the pin of the mount base. (See Figure 2)

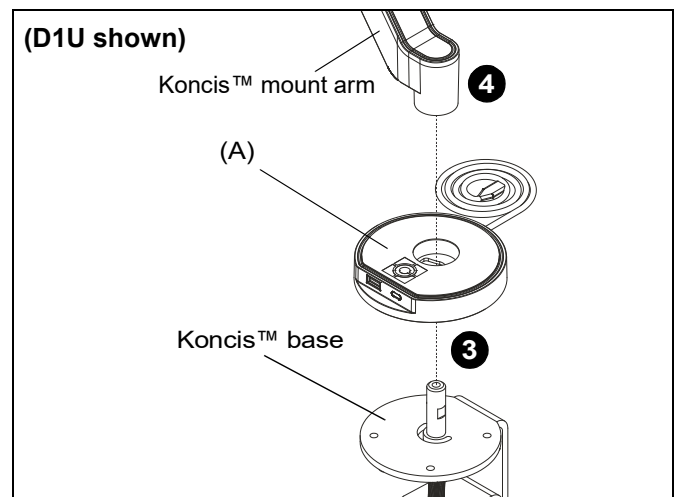

Figure 2

5. Plug cable into power source. Use wall charger (B) as desired.
6. Plug in any electrical devices as desired making sure not to exceed the following power ratings:
 - One USB type "A", one USB type "C": 5Vdc, 3.1A/ 15W (shared) (See Figure 3)

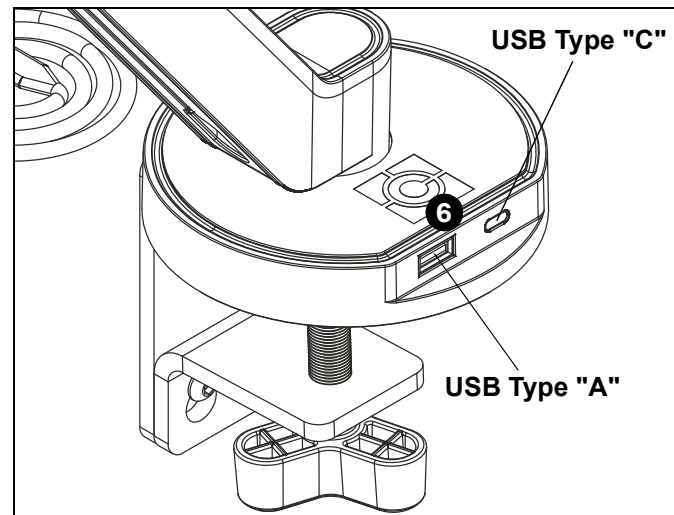

Figure 3



A brand of  **legrand**

8800-003306 Rev00
©2021 Legrand | AV
www.legrandav.com
08/21

USA/International	A 6436 City West Parkway, Eden Prairie, MN 55344 P 800.582.6480 / 952.225.6000 F 877.894.6918 / 952.894.6918
Europe	A Franklinstraat 14, 6003 DK Weert, Netherlands P +31 (0) 495 580 852 F +31 (0) 495 580 845
Asia Pacific	A Office No. 918 on 9/F, Shatin Galleria 18-24 Shan Mei Street Fotan, Shatin, Hong Kong P 852 2145 4099 F 852 2145 4477

