

# INSTALLATION INSTRUCTIONS

**Touchboards**

205 Westwood Ave, Long Branch, NJ 07740  
Phone: 866-94 BOARDS (26273) / (732)-222-1511  
Fax: (732)-222-7088 | E-mail: sales@touchboards.com

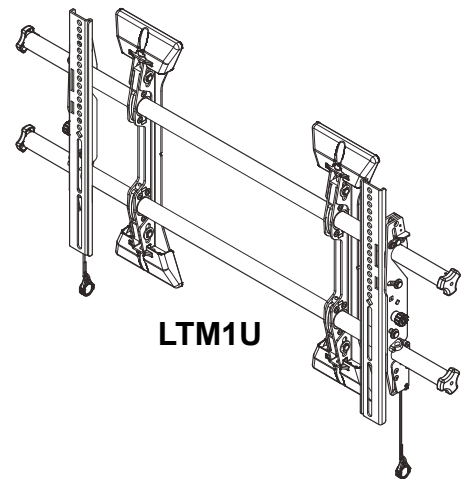
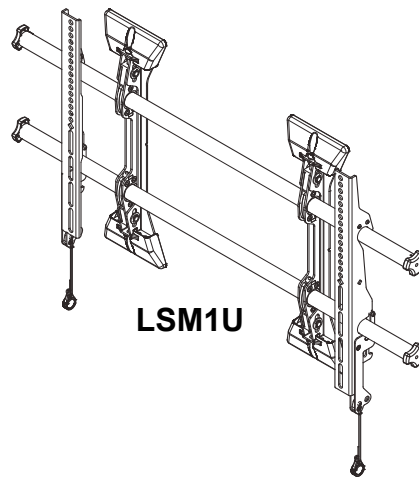
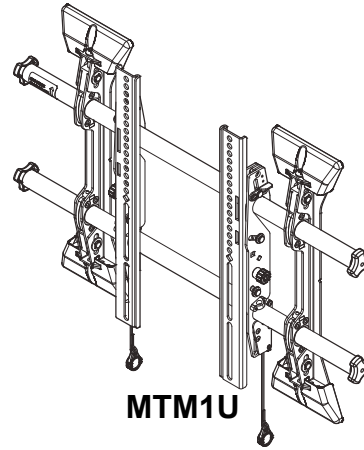
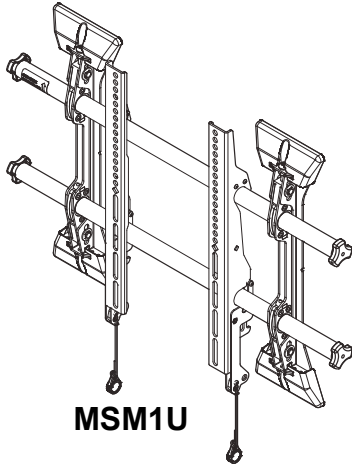

## FUSION HEIGHT ADJUST FLAT PANEL MOUNTS

## DISCLAIMER

Milestone AV Technologies, and its affiliated corporations and subsidiaries (collectively "Milestone"), intend to make this manual accurate and complete. However, Milestone makes no claim that the information contained herein covers all details, conditions or variations, nor does it provide for every possible contingency in connection with the installation or use of this product. The information contained in this document is subject to change without notice or obligation of any kind. Milestone makes no representation of warranty, expressed or implied, regarding the information contained herein. Milestone assumes no responsibility for accuracy, completeness or sufficiency of the information contained in this document.

Chief® is a registered trademark of Milestone AV Technologies. All rights reserved.

## DEFINITIONS

**WARNING:** A WARNING alerts you to the possibility of serious injury or death if you do not follow the instructions.

**CAUTION:** A CAUTION alerts you to the possibility of damage or destruction of equipment if you do not follow the corresponding instructions.

**MOUNTING SYSTEM:** A MOUNTING SYSTEM is the primary Chief product to which an accessory and/or component is attached.

**ACCESSORY:** AN ACCESSORY is the secondary Chief product which is attached to a primary Chief product, and may have a component attached or setting on it.

**COMPONENT:** A COMPONENT is an audiovisual item designed to be attached or resting on an accessory or mounting system such as a video camera, CPU, screen, display, projector, etc.

## IMPORTANT SAFETY INSTRUCTIONS

**WARNING:** Failure to read, thoroughly understand, and follow all instructions can result in serious personal injury, damage to equipment, or voiding of factory warranty! It is the installer's responsibility to make sure all parts are properly assembled and installed using the instructions provided.

**WARNING:** Failure to provide adequate structural strength for this mounting system can result in serious personal injury or damage to equipment! It is the installer's responsibility to make sure the structure to which this mounting system is attached can support five times the combined weight of all equipment. Reinforce the structure as required before installing the mounting system.

**WARNING:** Exceeding the weight capacity can result in serious personal injury or damage to equipment! It is the installer's responsibility to make sure the combined weight of all components located on the MSM1U/MTM1U does not exceed 125 lbs (56.7 kg); OR 200 lbs (90.7 kg) for the LSM1U/LTM1U.

**WARNING:** Use this mounting system only for its intended use as described in these instructions. Do not use attachments not recommended by the manufacturer.

**WARNING:** Never operate this mounting system if it is damaged. Return the mounting system to a service center for examination and repair.

**WARNING:** Do not use this product outdoors.

**IMPORTANT ! :** The MSM1U/MTM1U/LSM1U/LTM1U mounts are designed to be mounted to:

- a bare 8" concrete or 8"x8"x16" concrete block wall, or
- a 2" x 4" wood studs wall covered by drywall with maximum thickness of 5/8":
  - **MSM1U/MTM1U:** Wood studs must be 16" on center;
  - **LSM1U/LTM1U:** Wood studs may be 16" or 24" on center.

**NOTE:** The MSM1U/MTM1U/LSM1U/LTM1U Fusion height-adjust mounts may be used with the UL Listed FCAV1U Fusion pull-out accessory.

**--SAVE THESE INSTRUCTIONS--**



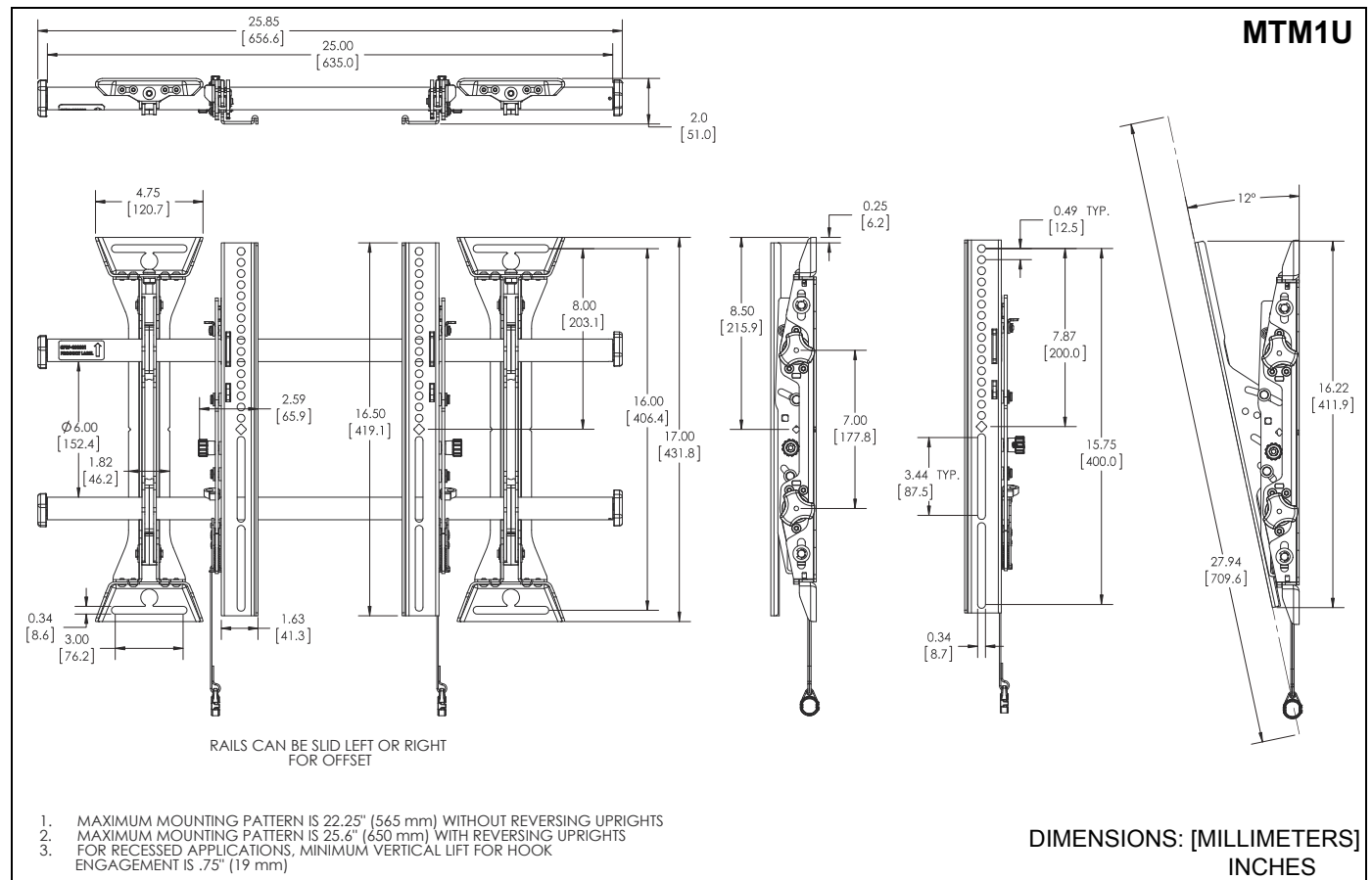
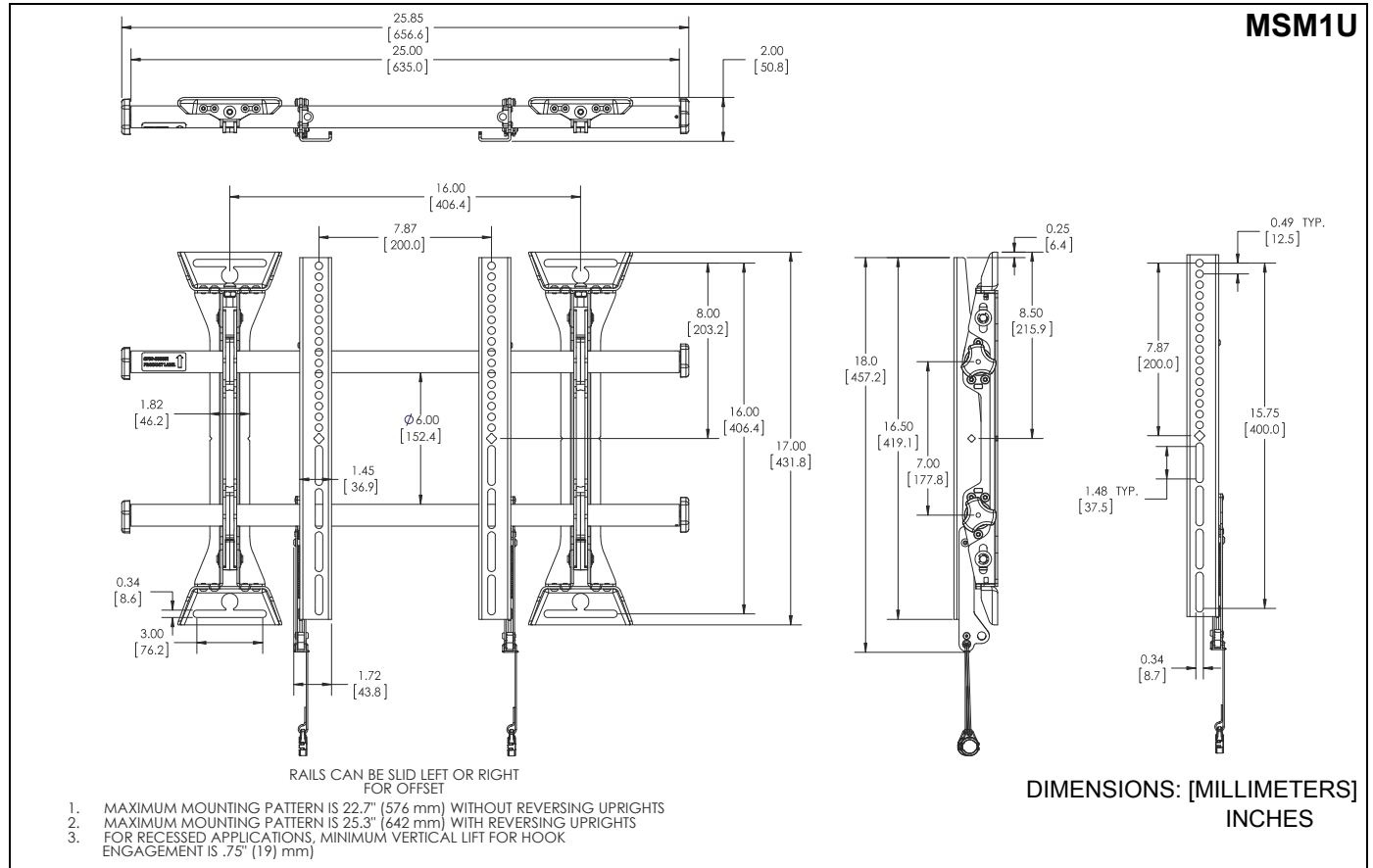



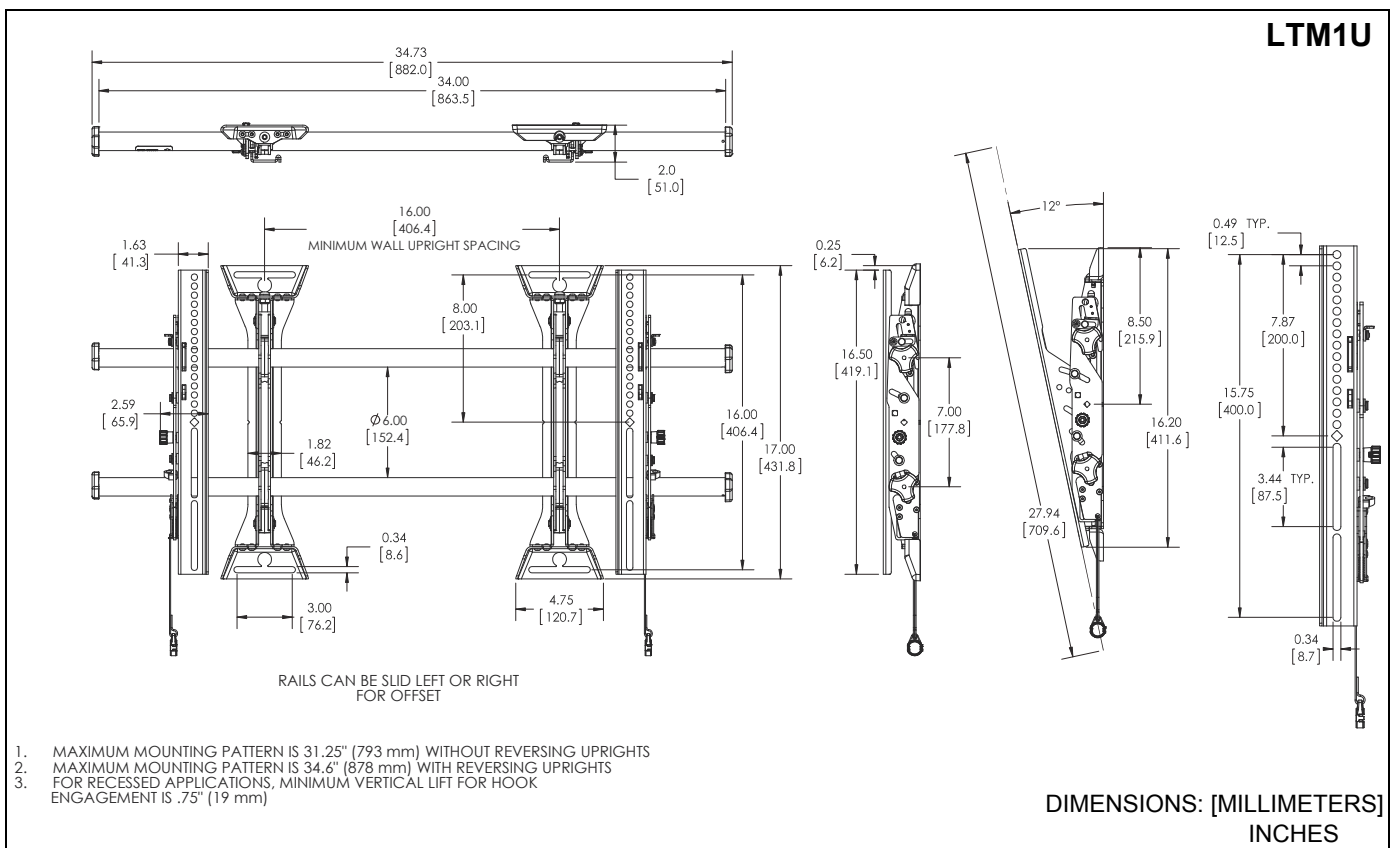
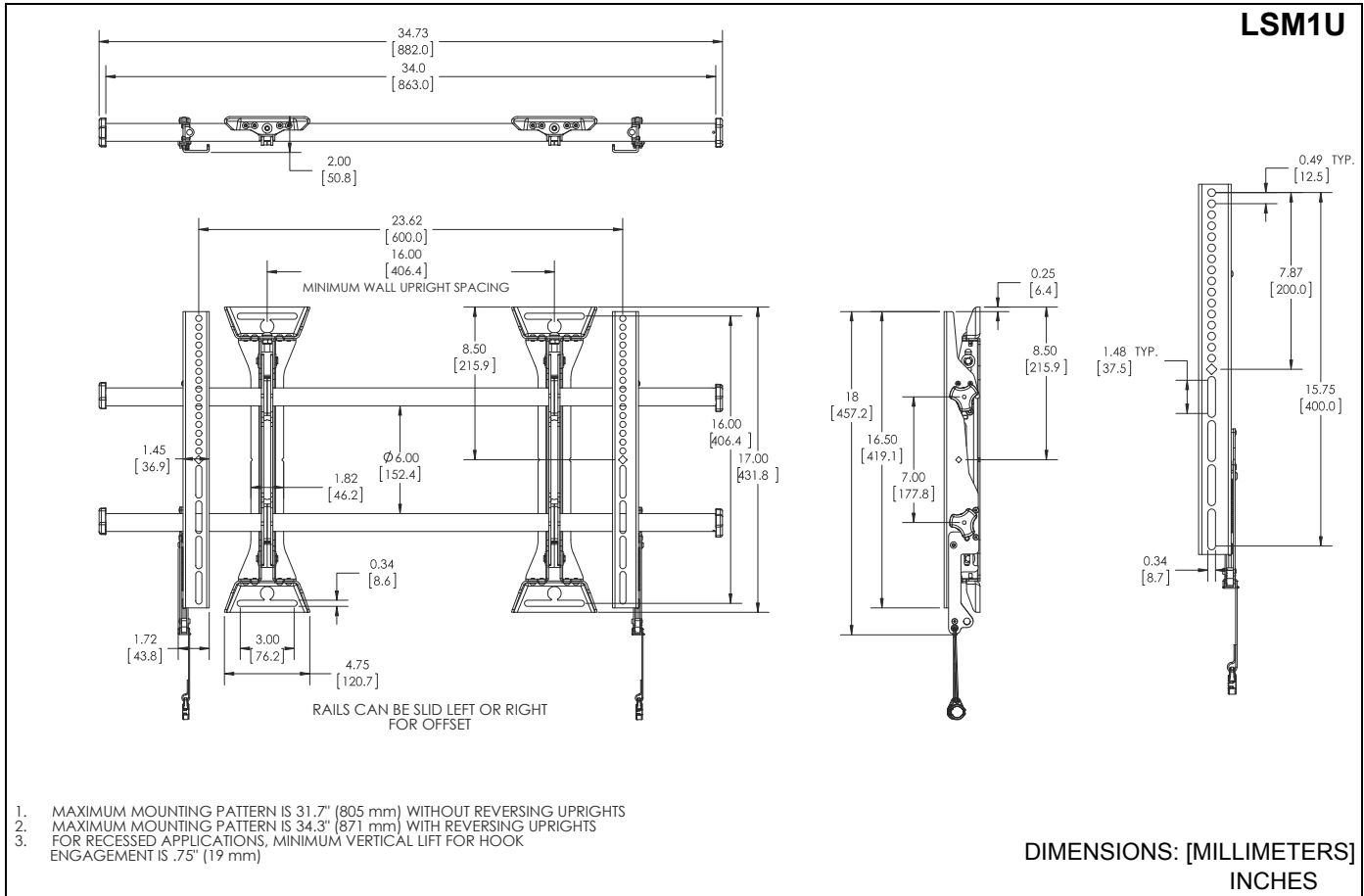



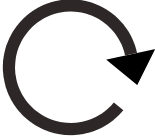

**DIMENSIONS**



**DIMENSIONS--continued**



**LEGEND**

	<p><b>Tighten Fastener</b>                      Apretar elemento de fijación                      Befestigungsteil festziehen                      Apertar fixador                      Serrare il fissaggio                      Bevestiging vastdraaien                      Serrez les fixations</p>		<p><b>Pencil Mark</b>                      Marcar con lápiz                      Stiftmarkierung                      Marcar com lápis                      Segno a matita                      Potloodmerkteken                      Marquage au crayon</p>
	<p><b>Loosen Fastener</b>                      Aflojar elemento de fijación                      Befestigungsteil lösen                      Desapertar fixador                      Allentare il fissaggio                      Bevestiging losdraaien                      Desserrez les fixations</p>		<p><b>Drill Hole</b>                      Perforar                      Bohrloch                      Fazer furo                      Praticare un foro                      Gat boren                      Percez un trou</p>
	<p><b>Phillips Screwdriver</b>                      Destornillador Phillips                      Kreuzschlitzschraubendreher                      Chave de fendas Phillips                      Cacciavite a stella                      Kruiskopschroevendraaier                      Tournevis à pointe cruciforme</p>		<p><b>Adjust</b>                      Ajustar                      Einstellen                      Ajustar                      Regolare                      Afstellen                      Ajuster</p>
	<p><b>Open-Ended Wrench</b>                      Llave de boca                      Gabelschlüssel                      Chave de bocas                      Chiave a punte aperte                      Steeksleutel                      Clé à fourche</p>		<p><b>Remove</b>                      Quitar                      Entfernen                      Remover                      Rimuovere                      Verwijderen                      Retirez</p>
	<p><b>By Hand</b>                      A mano                      Von Hand                      Com a mão                      A mano                      Met de hand                      À la main</p>		<p><b>Optional</b>                      Opcional                      Optional                      Opcional                      Opzionale                      Optie                      En option</p>
	<p><b>Hex-Head Wrench</b>                      Llave de cabeza hexagonal                      Sechskantschlüssel                      Chave de cabeça sextavada                      Chiave esagonale                      Zeskantsleutel                      Clé à tête hexagonale</p>		<p><b>Security Wrench</b>                      Llave de seguridad                      Sicherheitsschlüssel                      Chave de segurança                      Chiave di sicurezza                      Veiligheidssleutel                      Clé de sécurité</p>

**TOOLS REQUIRED FOR INSTALLATION**

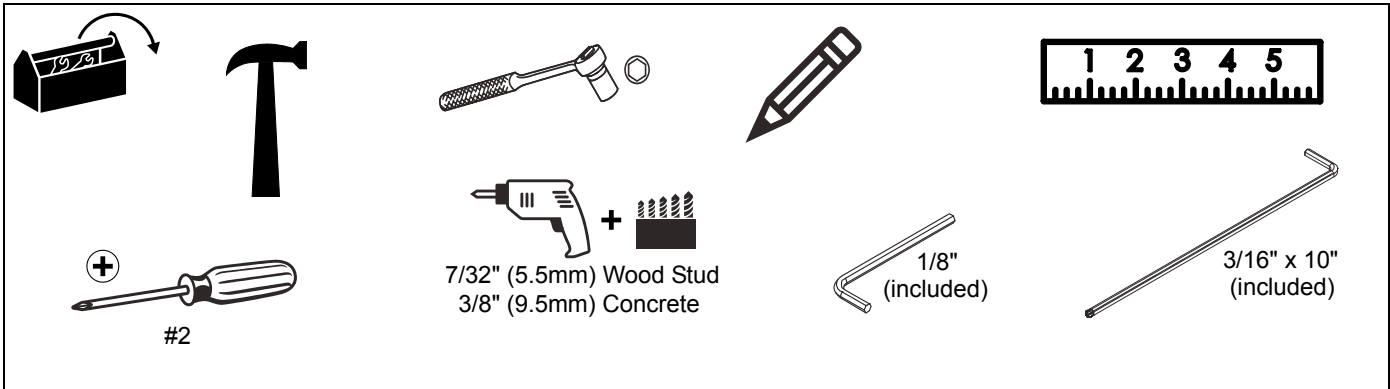

**PARTS**

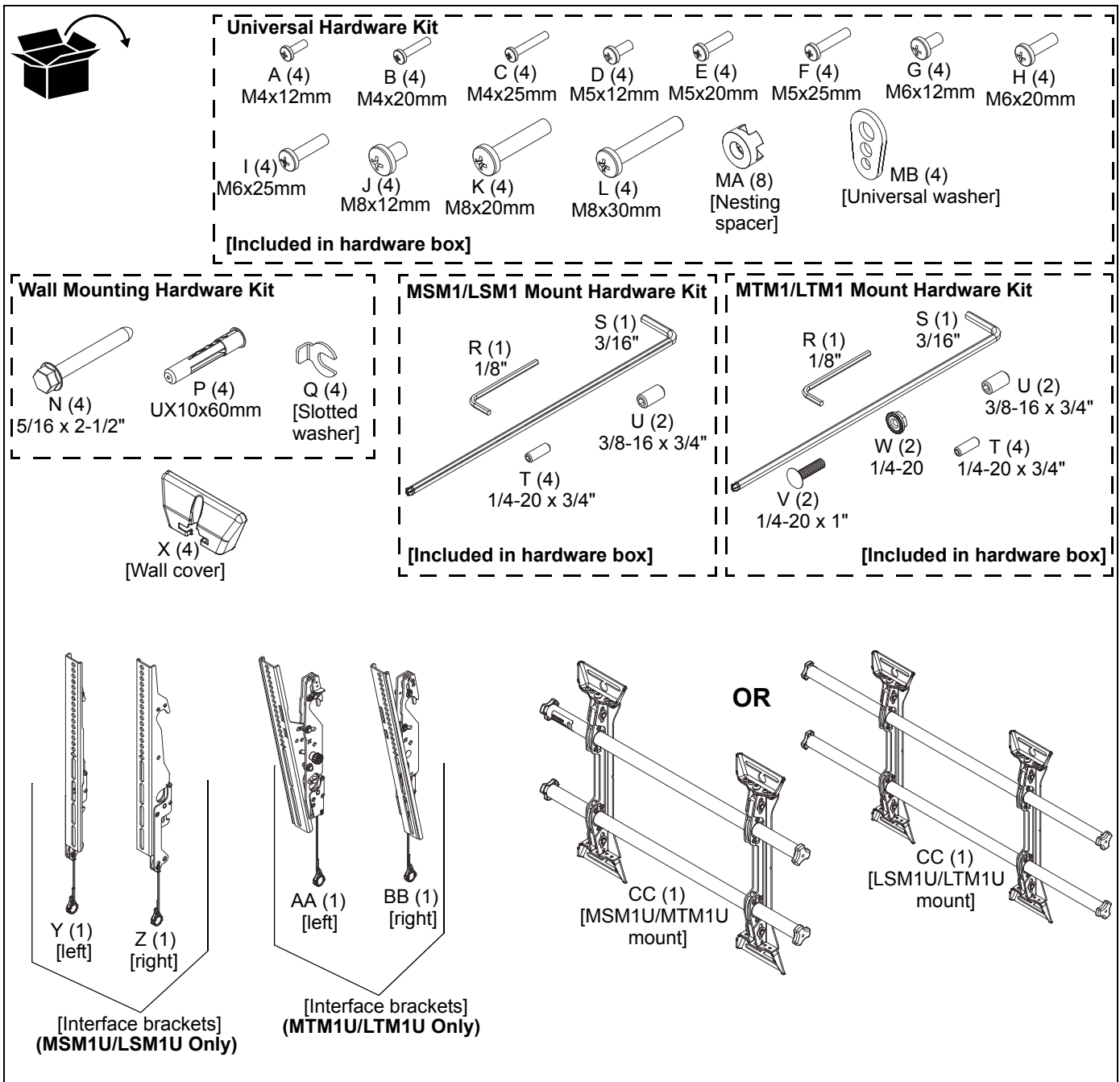

## INSTALLATION

The MSM1U/MTM1U/LSM1U/LTM1U mounts are designed to be mounted to a bare 8" concrete, 8"x8"x16" concrete block; or 2" x 4" wood studs (16" on center for MSM1U/MTM1U, and 16" or 24" on center for LSM1U/LTM1U) wall covered by drywall of 5/8" maximum thickness.

The MTM1U and LTM1U have brackets which allow the TV to be tilted. The MSM1U and LSM1U have static brackets which keep the TV in an upright position.

### Locate Mounting Site



**WARNING:** IMPROPER INSTALLATION CAN LEAD TO MOUNT FALLING CAUSING SEVERE PERSONAL INJURY OR DAMAGE TO EQUIPMENT! It is the installers responsibility to make certain the structure to which the mount is being attached is capable of supporting five times the combined weight of all components located on the mount, not to exceed 125 lbs (56.7 kg) for the MSM1U/MTM1U OR 200 lbs (90.7 kg) for the LSM1U/LTM1U.

**NOTE:** Proceed to either the **Installing to a Wood Stud Wall** section or the **Installing to a Concrete Wall** section.

### Installing to a Wood Stud Wall

1. Determine the center of the TV screen, and where it should be located on the wall.
2. Locate the closest stud to the left and right of the selected location.

**NOTE:** If the screen area lies over a stud, use that stud and the stud to either the left or right of it.

3. Line up the notches on mount (CC) with center of screen marking to determine vertical center. (See Figure 1)
4. Measure up 8" (203.2mm) from the center point to mark location of the upper mounting slots.

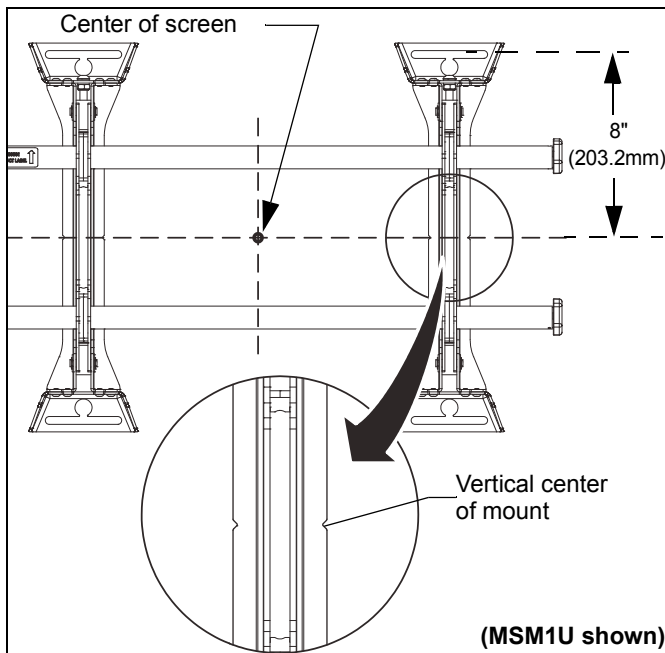

Figure 1

5. Using a level, mark the wall on each stud to attach the mount through the upper mounting slots. (See Figure 2)
6. Drill one 7/32" (5.5mm) pilot hole in each stud.
7. Partially install two 5/16 x 2-1/2" flanged lag bolts (N) into pilot holes but do not tighten to wall.
8. Hang mount (CC), aligning upper mounting slots over lag bolts and adjust side-to-side for proper location.
9. Place one slotted washer (Q) over each flanged lag bolt. (See Figure 2)
10. Tighten lag bolts to secure mount (CC) to wall at upper mounting slots.

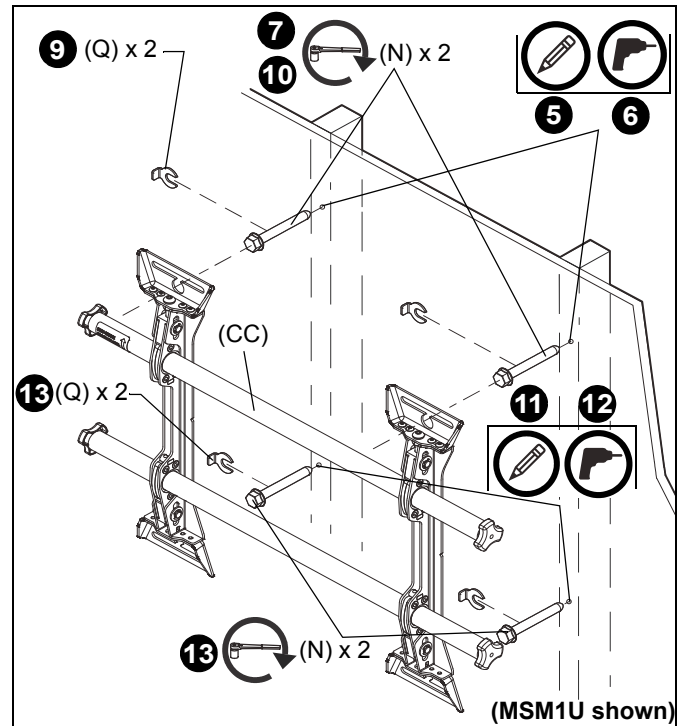

Figure 2

11. Mark the attachment points for the lower mounting slots, making sure the attachment points are located on the studs. (See Figure 2)
12. Drill 7/32" (5.5mm) pilot holes at markings for lower mounting holes. (See Figure 2)
13. Use two 5/16 x 2-1/2" flanged lag bolts (N) and two 5/16" slotted washers (Q) to attach the mount to the wall through the lower mounting holes. (See Figure 2)
14. Slide rails to approximate center of screen location.
15. Proceed to **Locking Rails** section.

### Installing to a Concrete Wall

1. Determine the center of the TV screen, and where it should be located on the wall.
2. Line up the notches on mount (CC) with center of screen marking to determine vertical center. (See Figure 1)
3. Measure up 8" (203.2mm) from the center point to mark location of the upper mounting slots. (See Figure 1)
4. Using a level, mark the wall through both upper mounting slots. (See Figure 3)

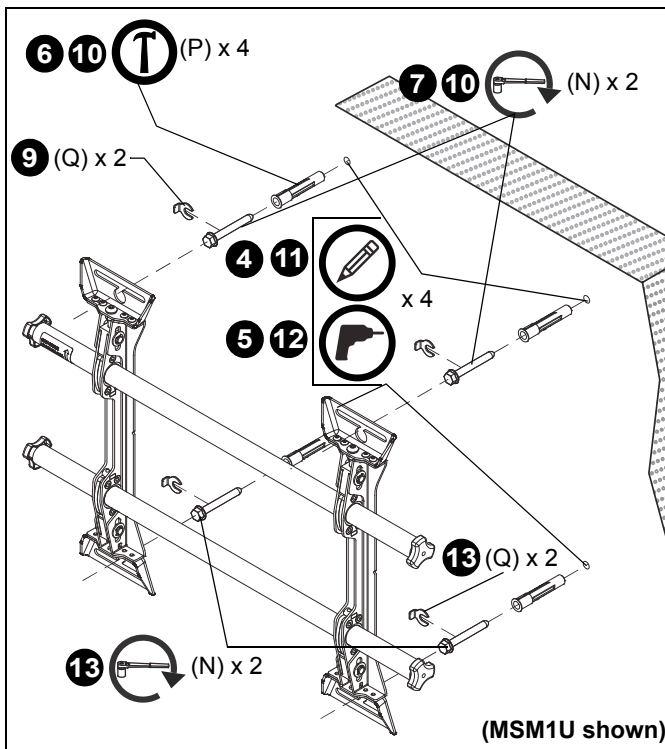

Figure 3



**CAUTION:** MINIMUM HORIZONTAL DISTANCE BETWEEN WALL BRACKETS IS 16" (406.4mm). Do not place mounting brackets closer together than 16" (406.4mm).

5. Drill one 3/8" x 3-1/2" (9.5mm x 88.9mm) pilot hole at each marking.
6. Install an anchor (P) into each pilot hole using a hammer, making sure that the anchor is flush with the wall.
7. Partially install two 5/16 x 2-1/2" flanged lag bolts (N) into pilot holes but do not tighten to wall.
8. Hang mount (CC), aligning upper mounting slots over lag bolts and adjust side-to-side for proper location.
9. Place one slotted washer (Q) over each flanged lag bolt. (See Figure 3)
10. Tighten lag bolts to secure mount (CC) to wall at upper mounting slots.
11. Mark the attachment points for the lower mounting slots, making sure the attachment points are located on the studs. (See Figure 3)

12. Drill 3/8" x 3-1/2" (9.5mm x 88.9mm) pilot holes at markings for lower mounting holes. (See Figure 3)
13. Use two 5/16 x 2-1/2" flanged lag bolts (N) and two 5/16" slotted washers (Q) to attach the mount to the wall through the lower mounting holes. (See Figure 3)
14. Slide rails to approximate center of screen location.

### Locking Rails (Optional)

1. Lock rails into place using two 1/4-20 x 3/4" set screws (T) on mount upright (CC) and the 1/8" hex key (R). (See Figure 4)
2. Repeat for remaining mount upright.

**NOTE:** To easily install upper set screw against upper rail, place set screw (T) onto hex key (R), and feed up into hole while turning to tighten.

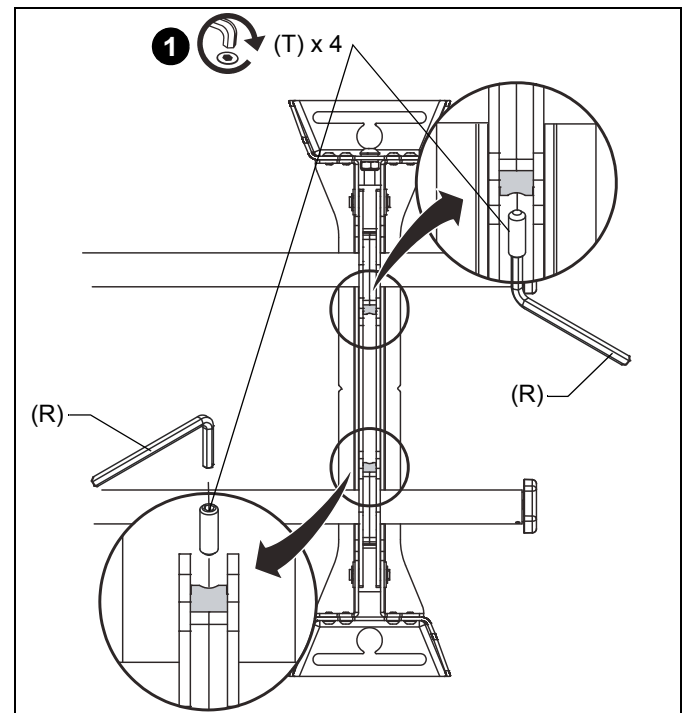

Figure 4



**Attaching Interface Brackets to Screen**

1. Align the center of the bracket (Y and Z or AA and BB) with center of screen. (See Figure 5)

**NOTE:** The diamond-shape holes in the bracket correspond to the center of the mount.

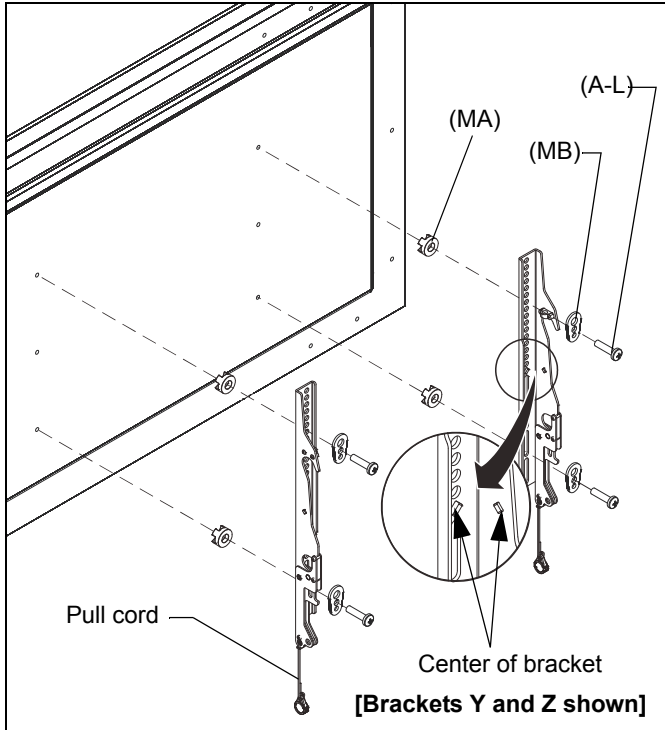

**Figure 5**

**WARNING:** IMPROPER INSTALLATION CAN LEAD TO DISPLAY FALLING CAUSING SERIOUS PERSONAL INJURY OR DAMAGE TO EQUIPMENT! Using screws of improper size may damage your display. Properly sized screws will easily and completely thread into display mounting holes. If spacers are required, be sure to use longer screws of the same diameter.

2. Select correct screws, nesting spacers (if necessary) and universal washers from the hardware bag (A-M) and attach brackets to back of screen. (See Figure 5)

**IMPORTANT ! : (LSM1U/LTM1U Only)** If M4 fasteners are used to attach brackets to back of screen, the weight of the screen may NOT exceed 150 lbs (68.0 kg).

**NOTE:** The nesting spacers (MA) may be used separately, or put two together in different configurations to create different size spacers. (See Figure 6)

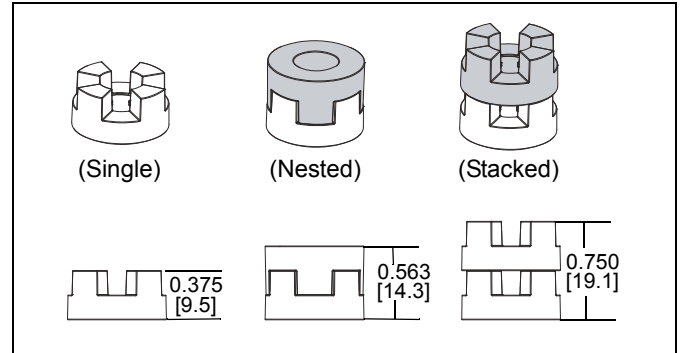
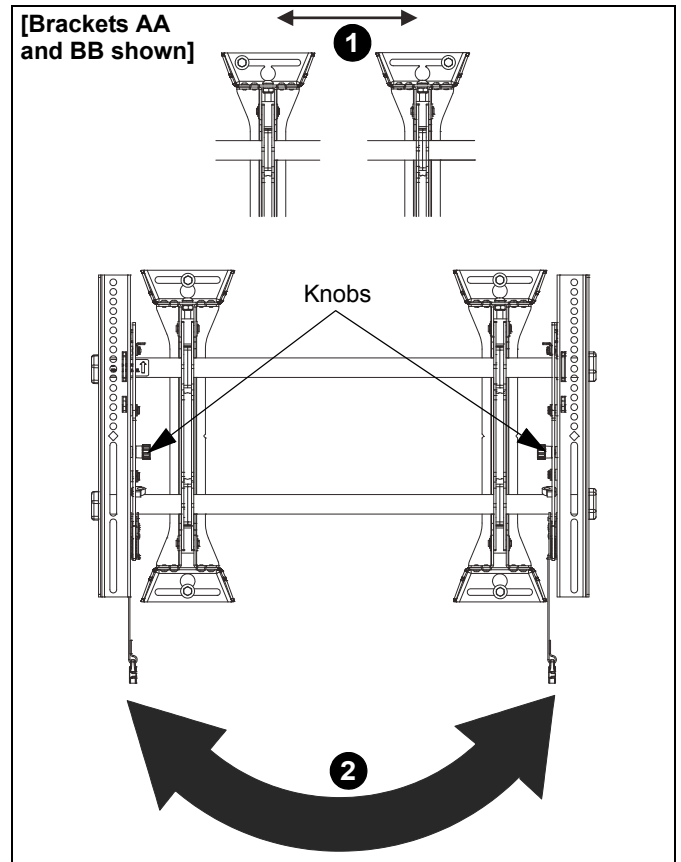

**Figure 6**

**Switching Interface Brackets (Optional)**

If an installation situation makes adjusting the location of interface brackets necessary, there are several options.

1. The wall brackets may be adjusted side to side at the point of attachment. (See Figure 7)
2. The location of the left and right interface brackets (Y and Z or AA and BB) may be switched, with the knobs on the MTM1U/LTM1U interface brackets (AA and BB) facing the inside of the mount. (See Figure 7)



**Figure 7**

3. If necessary, the tilt interface bracket knobs may be switched to allow the interface brackets (AA and BB) to be reversed. (See Figure 8)
  - a. Remove display from mount.
  - b. Remove interface brackets from display.
  - c. Hold the right interface bracket horizontally, tightly gripping it so that spacers do not move.
  - d. Remove the knob and screw.
  - e. Replace the knob and screw in the opposite order, with the knob on the inside of the bracket.
  - f. Switch the right interface bracket to the left side of the wall mount.
  - g. Repeat Steps 3c through 3f with the left interface bracket.

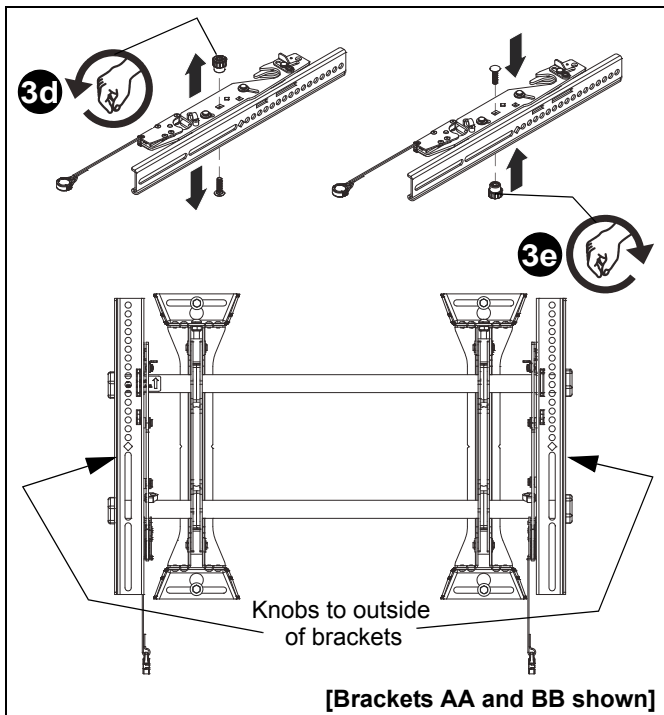

Figure 8

**Attaching Screen to Wall Mount**

1. Attach wall covers (X) to top and bottom of both wall brackets. (See Figure 9)

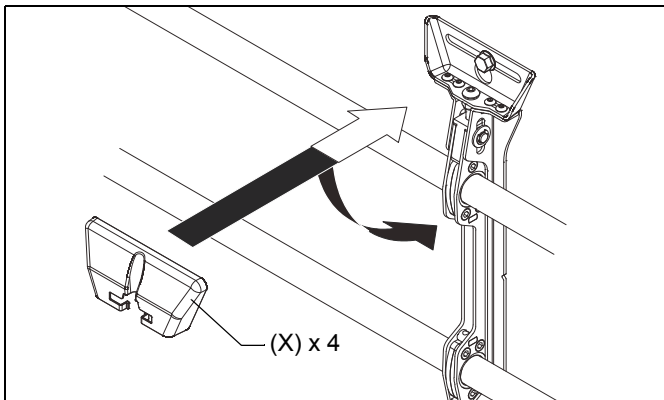

Figure 9

**NOTE:** NEVER place both interface brackets (Y and Z or AA and BB) to one side of the wall mount center line! (See Figure 10)

**NOTE:** Do NOT allow both interface brackets (Y and Z or AA and BB) to be located on same side of wall bracket. (See Figure 10)

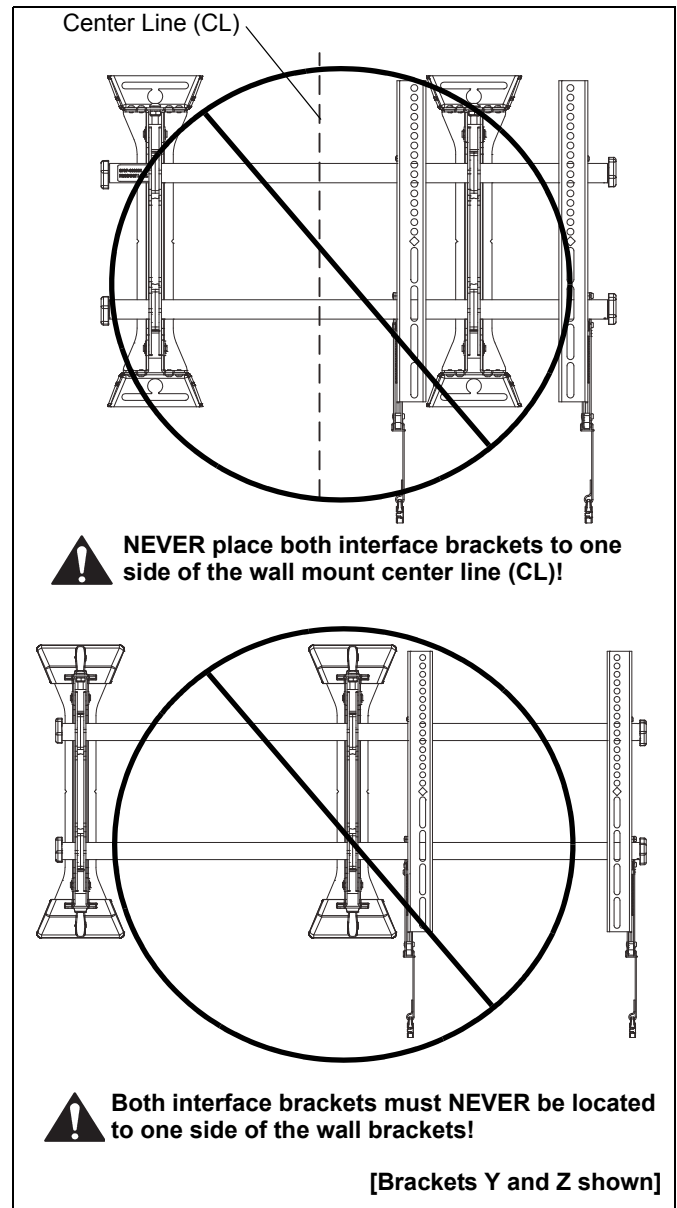

Figure 10

2. Hang screen onto the top rail of the mount (CC). (See Figure 11)
  - **MSM1U / LSM1U:** Hang top hook of interface brackets (Y and Z) onto the top rail of the mount (CC). (See Figure 11)
  - **MTM1U / LTM1U:** Move latch on top of interface bracket to OPEN position and hang top hook of interface brackets (AA and BB) onto the top rail of the mount (CC). (See Figure 11)

**NOTE:** The screen initially installs into the "service mode" to allow easy cable access.

3. Adjust screen and rails to desired viewing position.
4. Route cables between wall and rails.



**CAUTION:** PINCH POINTS! Keep fingers, hands and cables out of pinch point areas.

5. Pull downward on the pull cords and swing inward toward wall, latching interface brackets to lower rail and fastening bottom of screen to the mount. (See Figure 11)
6. Attach end of pull cord (a magnet) to mount so it does not extend beyond bottom of screen. (See Figure 11)

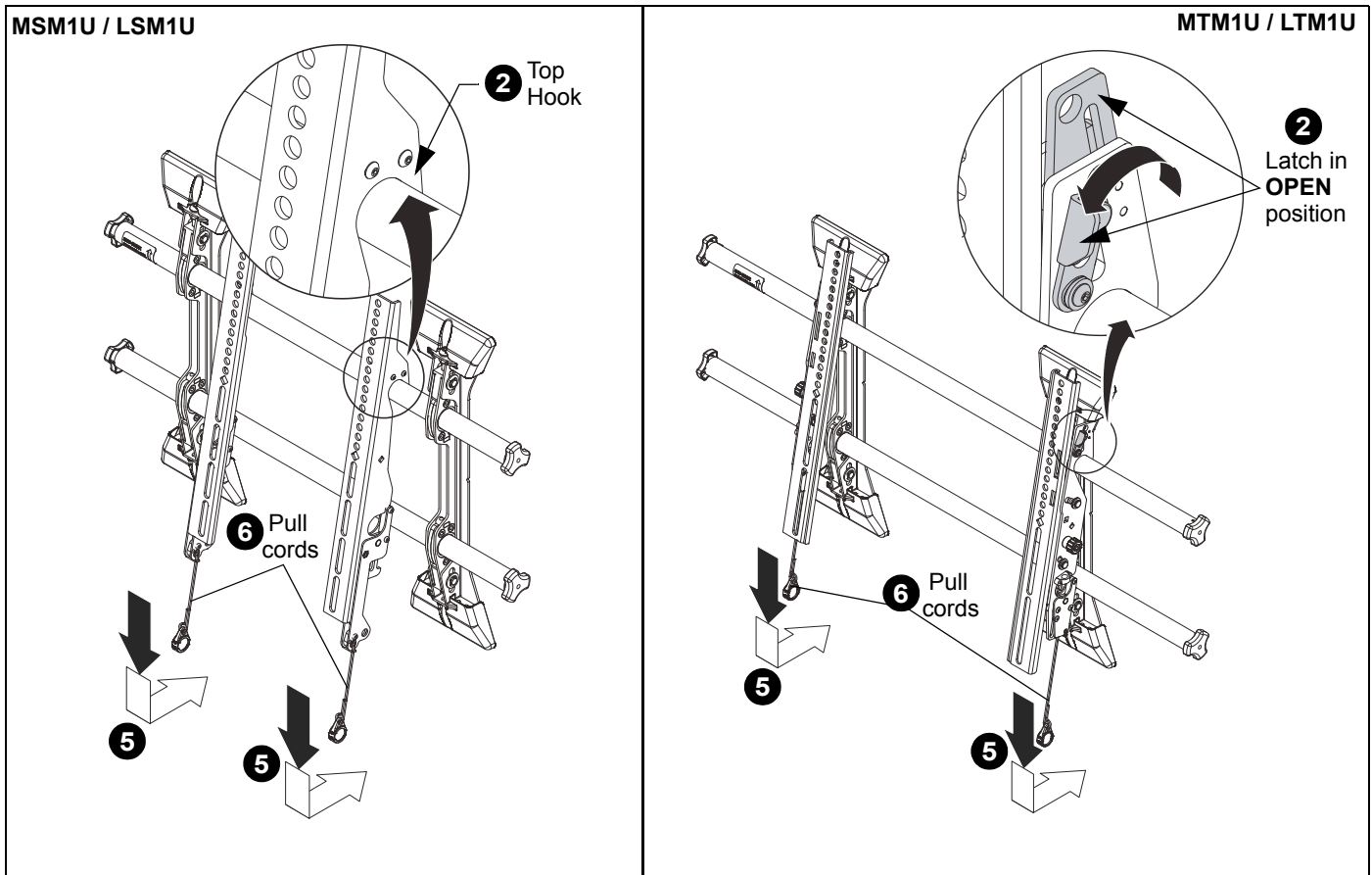

Figure 11

## Adjustments

### Horizontal Adjustment

1. The mount wall brackets may be adjusted side to side at the point of attachment. (See Figure 12)

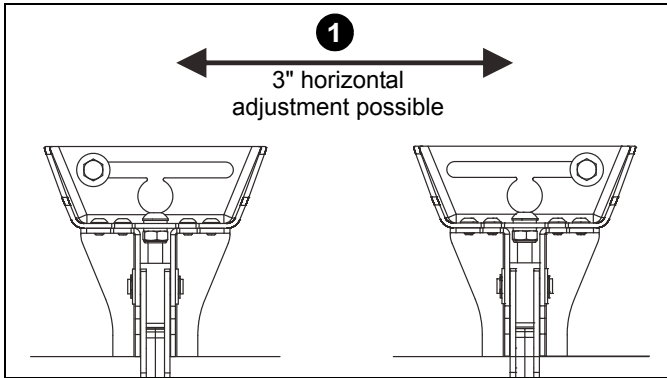

Figure 12

2. The screen may be adjusted along rails side to side.

**NOTE:** NEVER place both interface brackets (Y and Z or AA and BB) to one side of the wall mount center line! (See Figure 10)

**NOTE:** Do NOT allow both interface brackets (Y and Z or AA and BB) to be located on same side of wall bracket. (See Figure 10)

3. (MTM1U / LTM1U only) Move latch on top of interface brackets to CLOSED position. (See Figure 14)

### Roll/Height Adjustment of Wall Brackets

**NOTE:** The height adjust wall brackets allow adjustment of  $\pm 1/2$ ".

1. Turn to right (tighten) to raise side of screen. (See Figure 13)
2. Turn to left (loosen) to lower side of the screen.

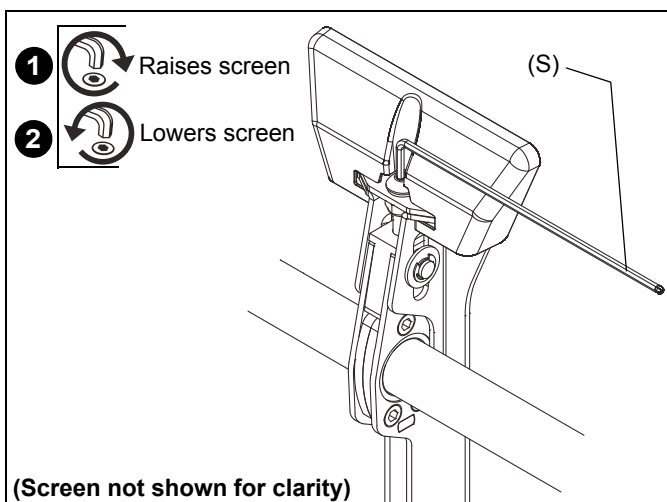

Figure 13

### Tilt (MTM1U / LTM1U Only)

The interface brackets (AA and BB) allow from  $-2^{\circ}$  to  $12^{\circ}$  tilt, and can be locked at  $0^{\circ}$ ,  $6^{\circ}$  and  $12^{\circ}$ .

1. Loosen the interface bracket knob.
2. Adjust tilt as required. (See Figure 14)
3. The tilt may be locked at  $0^{\circ}$ ,  $6^{\circ}$  or  $12^{\circ}$  using one 1/4-20 x 1" round head carriage bolt (V) and one 1/4-20 hex nut (W) per interface bracket. (See Figure 14)
4. Tighten interface bracket knob as necessary.

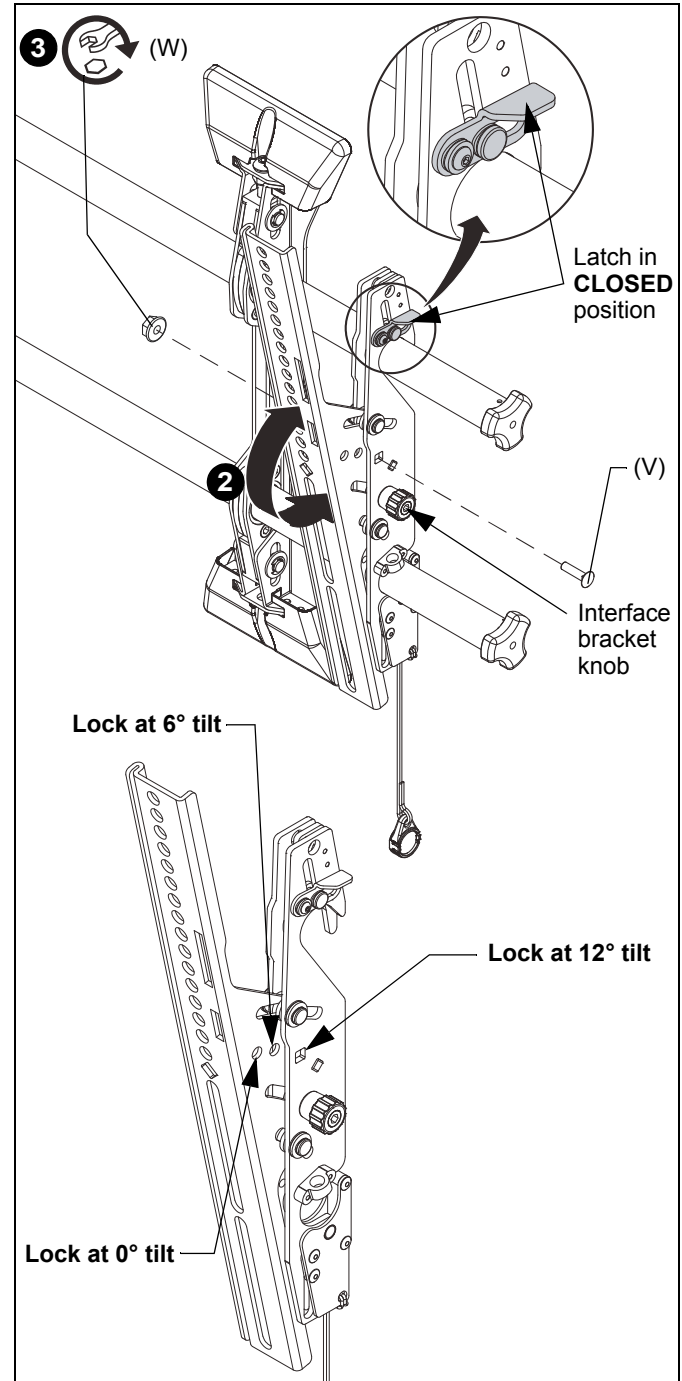
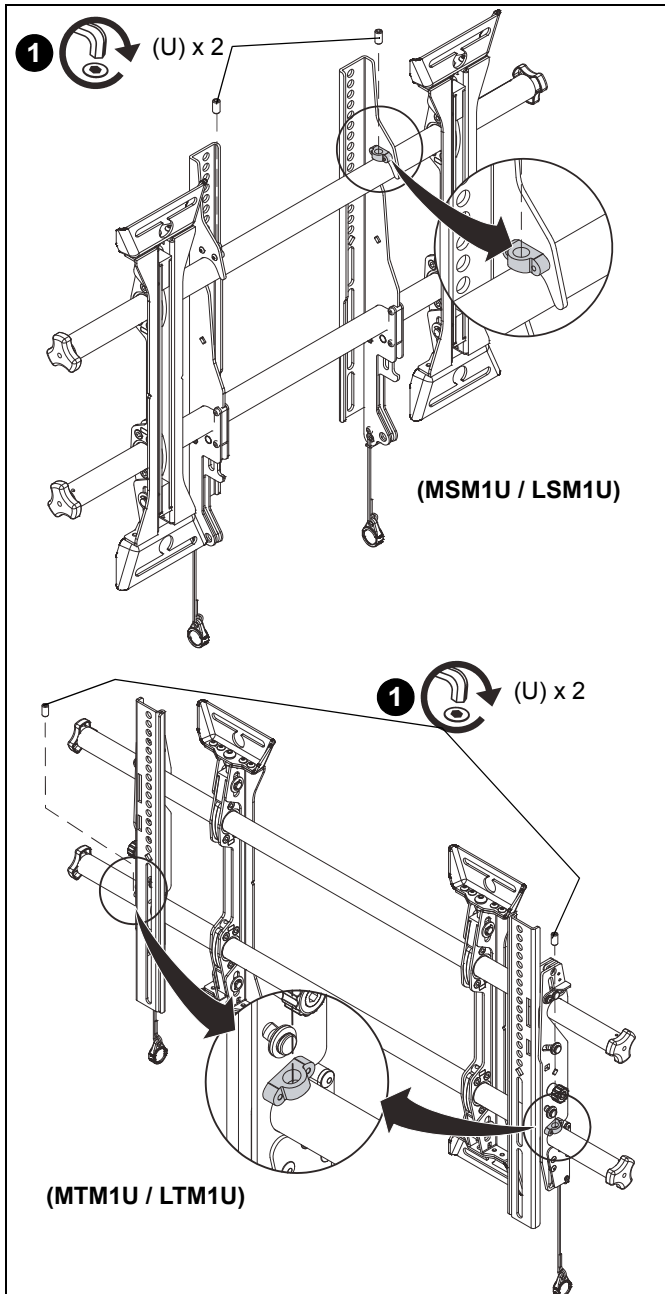

Figure 14

**Locking Screen Interface Brackets (Optional)**

1. Lock screen interface brackets onto mount rails using one 3/8-16 x 3/4" set screw (U) on each interface bracket. (See Figure 15)

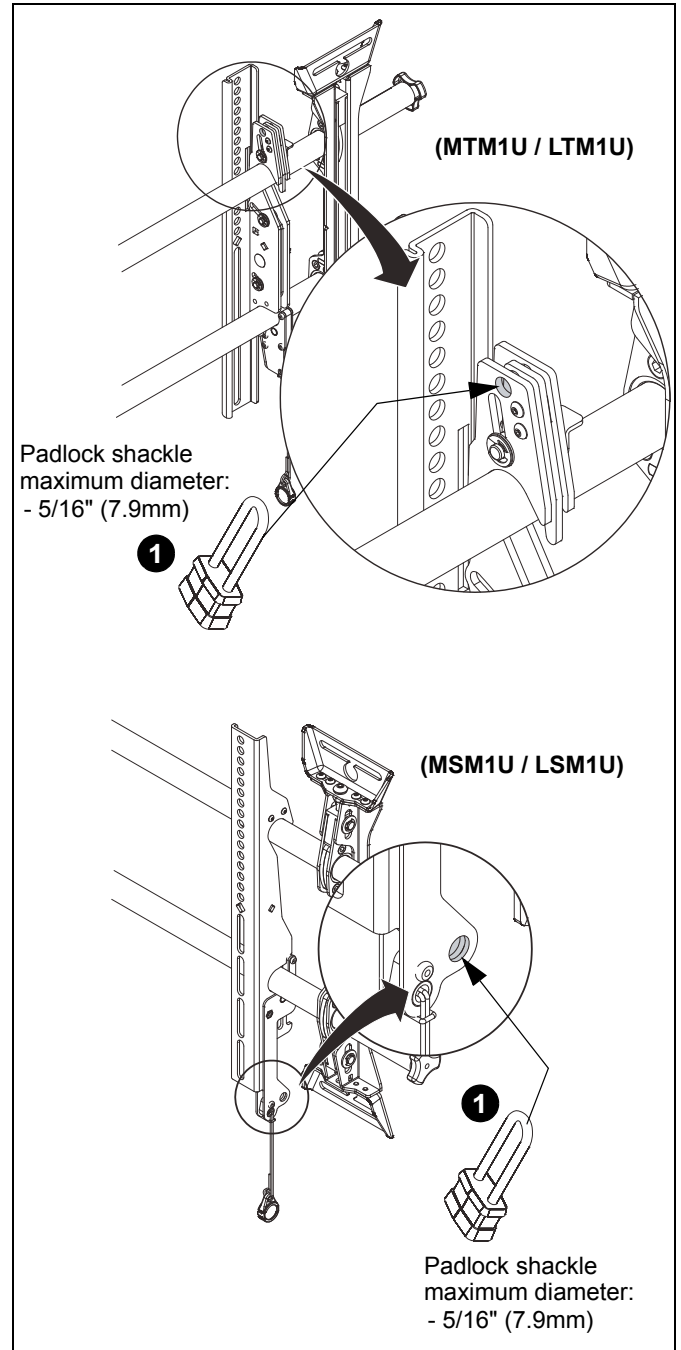

**Figure 15**

**Locking Mount (Optional)**

1. Add padlock (not included) to interface bracket to complete security. (See Figure 16)

**NOTE:** The padlock maximum shackle diameter is 5/16" (7.9 mm).



**Figure 16**







Our Mounts. **Your Vision.**

Chief, a products division of  
Milestone AV Technologies

8800-002623 Rev03  
©2016 Milestone AV Technologies  
[www.chiefmfg.com](http://www.chiefmfg.com)  
01/16

<b>USA/International</b>	<b>A</b> 6436 City West Parkway, Eden Prairie, MN 55344
	<b>P</b> 800.582.6480 / 952.225.6000
	<b>F</b> 877.894.6918 / 952.894.6918
<b>Europe</b>	<b>A</b> Franklinstraat 14, 6003 DK Weert, Netherlands
	<b>P</b> +31 (0) 495 580 852
	<b>F</b> +31 (0) 495 580 845
<b>Asia Pacific</b>	<b>A</b> Office No. 918 on 9/F, Shatin Galleria 18-24 Shan Mei Street Fotan, Shatin, Hong Kong
	<b>P</b> 852 2145 4099
	<b>F</b> 852 2145 4477

