

**RECOMMENDED ELECTRICAL BOX:
RACO 560 3" X 2" BOX, 2 3/4" DEEP
GANGABLE OR EQUIVALENT.**

**RECOMMENDED ELECTRICAL BOX
COVER: RACO 864 SINGLE DUPLEX**

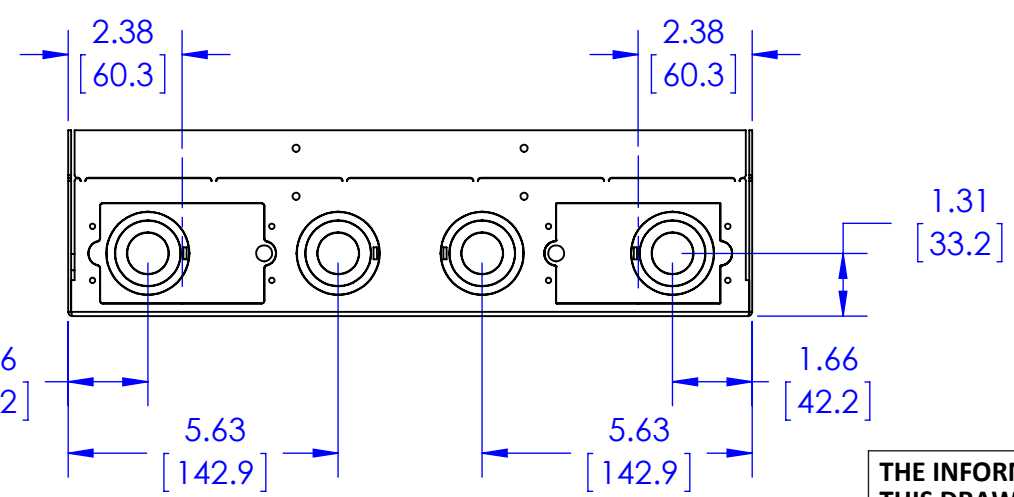
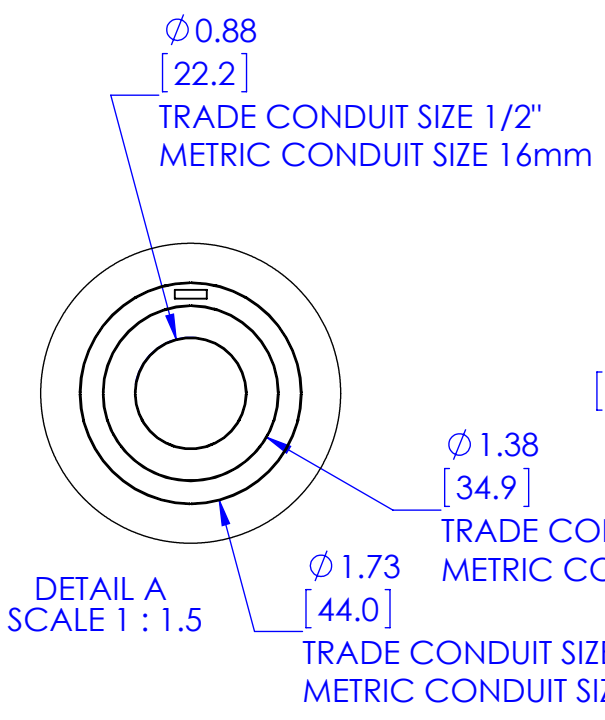
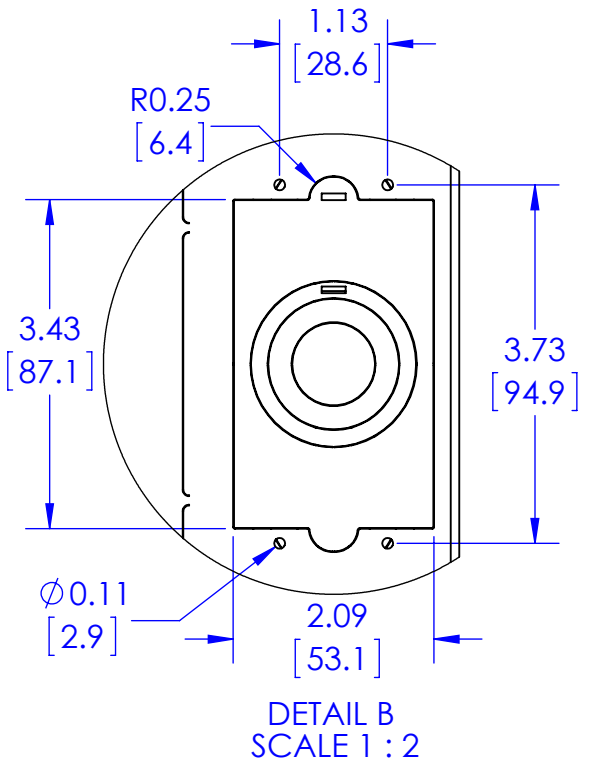
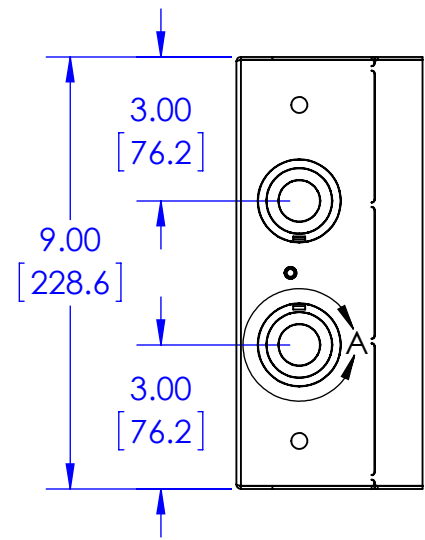
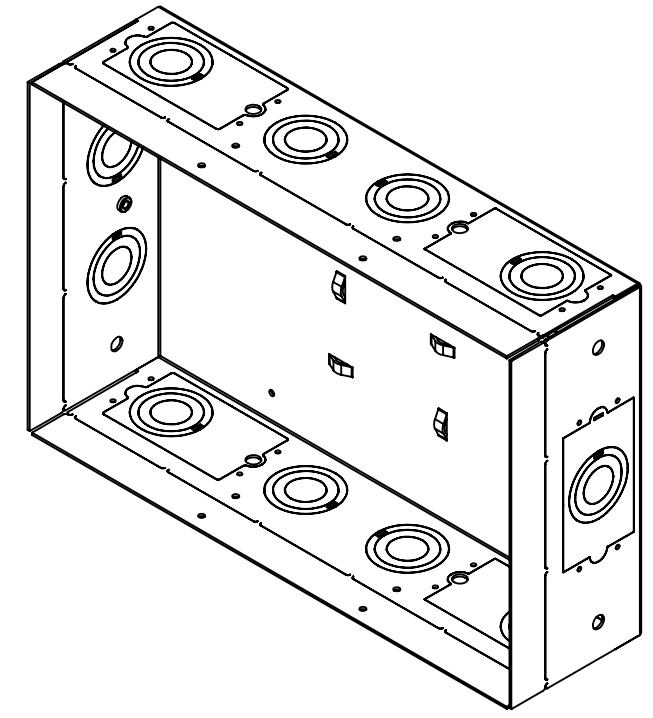
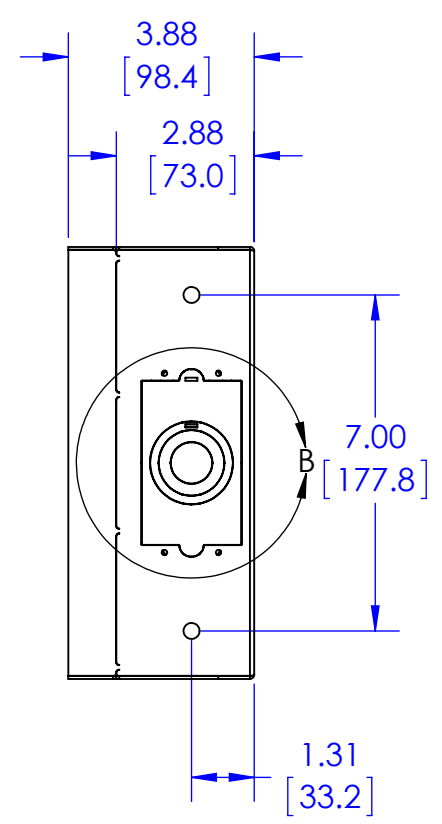
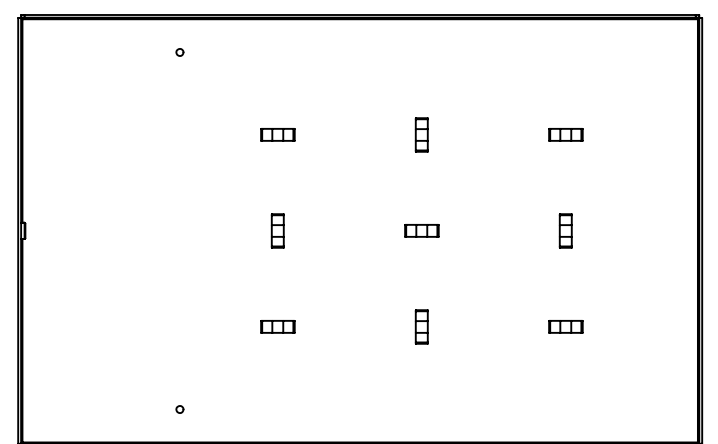
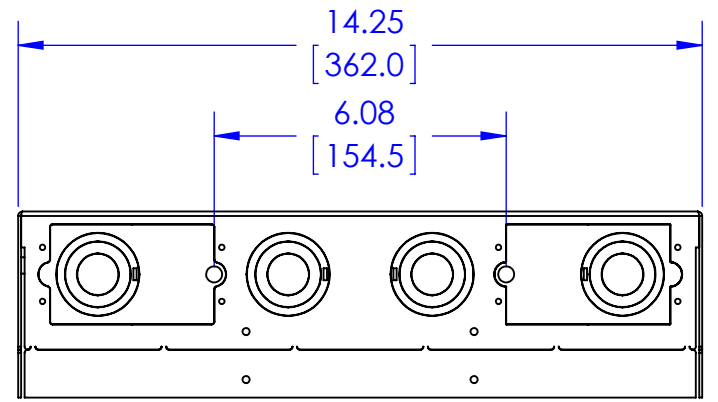

THE INFORMATION AND DESIGNS CONTAINED IN THIS DRAWING ARE CONFIDENTIAL AND THE PROPRIETARY PROPERTY OF MILESTONE AV TECHNOLOGIES NEITHER THIS DESIGN NOR ANY INFORMATION CONTAINED IN THIS DRAWING MAY BE REPRODUCED OR DISCLOSED TO OTHERS WITHOUT THE EXPRESS WRITTEN CONSENT OF MILESTONE AV TECHNOLOGIES.

CAD GENERATED DRAWING, DO NOT MANUALLY UPDATE.			
DRAWN BY	HEF	12/23/2013	<p>6436 CITY WEST PKWY EDEN PRAIRIE MN, 55344 PHONE: 866-977-3901 FAX: 877-894-6918</p>
ENG APPROVAL			
MFG APPROVAL			
QA APPROVAL			
SHEET 1 OF 1		SCALE 1:4	DESCRIPTION PAC525, WALL ENCLOSURE, 16 X 9
		SIZE B	MODEL NO. PAC525
			DWG. NO. TECH-000535
			REV. 00