

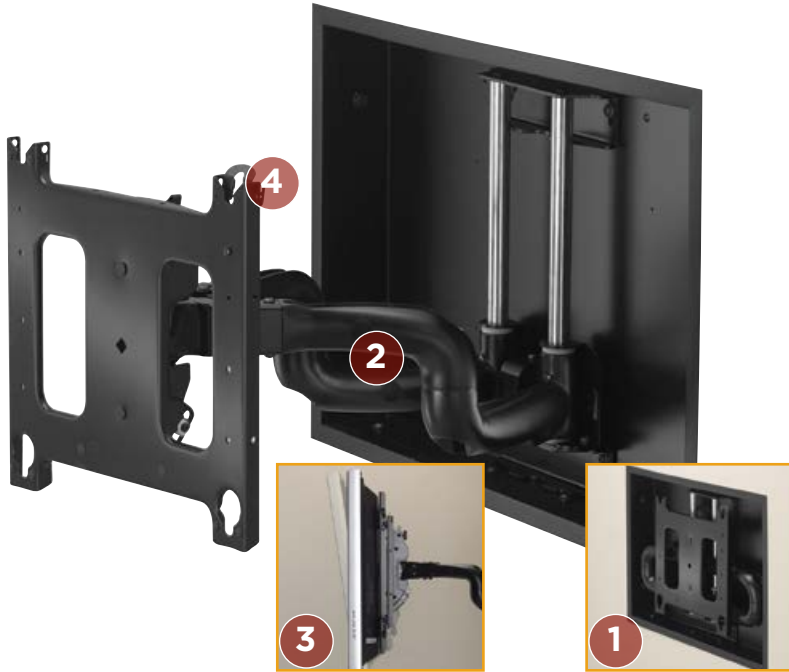

IN-WALL MOUNTS PAC501 & PNRIW □ IN-WALL BOX & SWING ARM

42-71" Screens



FEATURES

- 1 LOW PROFILE**
Designed to ensure mount remains concealed behind the screen.
- 2 SMOOTH EXTENSION**
Contoured swing arms are designed for effortless extension up to 22.4" (569 mm).
- 3 CENTRIS® FINGERTIP TILT**
Select the perfect tension for your screen's center of gravity to achieve smooth fingertip tilt. Screen angle stays set until you decide to readjust.
- 4 CLICKCONNECT™ LATCHING**
Hear an audible click when the screen engages with the mount. Easy to connect/disconnect - no tools needed!

WHAT YOU NEED TO KNOW

ORDERING INFORMATION

PAC501 and PNRIW must be ordered separately. Available in universal or custom:

- **UNIVERSAL:** Order PAC501 and PNRIWUB
- **CUSTOM:** Order PAC501, PNRIW2000B + PSBxxxx
See MountFinder™ PRO on chiefmfg.com for custom PSB model numbers.

OTHER PRODUCT OPTION



PIWRF
In-Wall Box Accessory and Swing Arm Mount

SPECIFICATIONS

Roll	±2°
Tilt	-15°, +5°
Swivel*	76.5° Left/Right
Extension Range	0.62" - 22.4" (16 - 569 mm)
Box Dimensions (HxWxD)	20" x 30" x 3.63" (508 x 762 x 92 mm)
Color	Black
Weight Capacity	200 lbs (90.7 kg)

* With 42" screen. Swivel range varies with screen size.

RECOMMENDED ACCESSORIES



PACHFK1 ■ Header/Footer Kit



PACCC1 ■ Center Channel Speaker Adapter



PACPC1 ■ Power Filter

TECHNICAL DRAWINGS

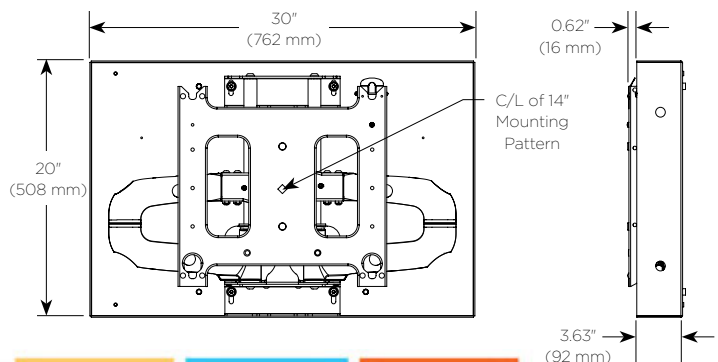

205 Westwood Ave, Long Branch, NJ 07740
Phone: 866-94 BOARDS (26273) / (732)-222-1511
Fax: (732)-222-7088 | E-mail: sales@touchboards.com